



Issue 9-16 E

H 4.306

Concentric Clamping Elements

2 and 3-point interior clamping, for interchangeable clamping jaws $\varnothing 16 - 121$ mm, double acting, max. operating pressure 250 bar



Application

This hydraulically-operated concentric clamping element can be equipped with especially low clamping jaws to receive workpieces with interior centrings of low depth.

Suitable workpieces can directly rest on the clamping jaws so that additional support points are not required.

With a combination of 2 and 3-point elements, workpieces with 2 centring holes can be exactly positioned.

Description

The 2 or 3 base jaws are coupled to a cone-shaped contact bolt in the centre of the housing, that is driven by a double acting hydraulic piston.

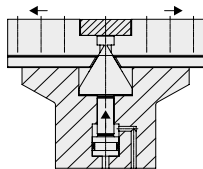

To obtain the required synchronization accuracy all parts are manufactured with high precision. The nitrated base jaws have 3 fixing threads. Depending on the desired centring diameter, the accordingly adjusted clamping jaws can always be fixed with at least 2 screws. The exact position of the clamping jaws is secured with 2 drill bushings.

Important notes

The concentric clamping elements are not only suitable for the use on turning machines.

If a workpiece is clamped by one concentric clamping element only, a tilting torque is produced by radial machining forces. Please pay attention to the chapter "Admissible machining forces" on page 2.

In the effective area of the clamping jaws there is the danger of crushing. The manufacturer of the fixture or the machine is obliged to provide effective protection devices.

Advantages

- Ideal for 5-sided machining
- Suitable for low centring depths
- Clamping jaws can be adapted to the work-piece
- Workpiece support on clamping jaws possible
- Centring repeatability 0.02 mm
- Stroke of clamping jaws 10 mm
- Connection for positive air pressure protection
- Pneumatic position monitoring
- Optional pneumatic contact control

Positive air pressure connection

The standard positive air pressure protection keeps the hole centre free of swarf, so that the base jaws can freely return.

Pneumatic stroke end control

The positive air pressure protection can also be used for the control of the unclamping position. The returning base jaws close in their end position the bore hole of the positive air pressure connection.

Optional contact control

In the version with contact control, pneumatic pressure is supplied to one of the base jaws, which is then transmitted into the clamping jaw. In the crowned clamping surface there is a small bore hole. If a workpiece is clamped correctly, it closes the bore hole.

Signal conversion: Pneumatic - electric

An electro-pneumatic measuring device can either signal the pressure increase or a drop of the air flow rate.

1. Pressure switch

The pressure switch signals the pressure increase when closing a blow hole. It is important that the pressure difference between open and closed blow hole is big enough to get a process-safe message.

2. Flow meter

The flow meter signals the drop of the air flow rate when closing a blow hole.

The flow meter should have a digital display and one adjustable limit switch (e.g. type SFAB of FESTO).

The switching threshold is set to a mean value between open and closed nozzle.

We recommend flow measurement, if only one pneumatic line is available for several elements.

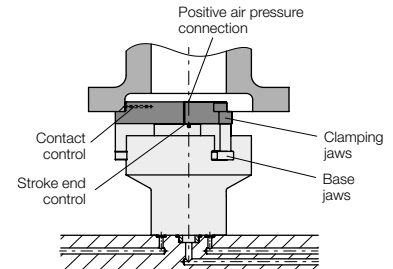
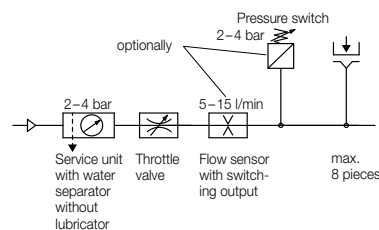

Applications

- Centre and clamp in 1 bore hole

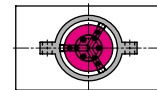

- Centre and clamp in 2 bore holes

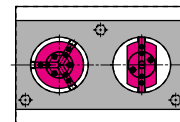

- Diagonally centre and clamp in 2 bore holes

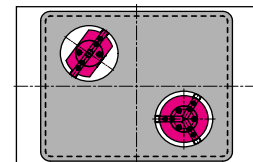

- Centre and clamp in longitudinal holes

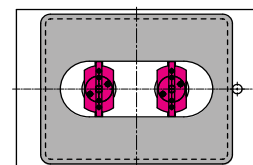

- Multiple clamping fixture

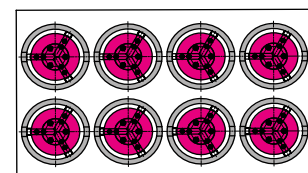

Technical data and dimensions Admissible machining forces

Technical data

Max. clamping force in total approx.	[kN]	5
Max. clamping force per jaw approx.		
2-point / 3-point	[kN]	2.5 / 1.67
Max. operating pressure	[bar]	250
Min. operating pressure	[bar]	20
Stroke of clamping jaws	[mm]	10
Centring repeatability	[mm]	0.02
Oil volume/clamping stroke	[cm³]	3.5
Oil volume/return stroke	[cm³]	1.6
Weight		
2-point / 3-point approx.	[kg]	2.54 / 2.60
Part no. 2-point		4312620P
Part no. 3-point		4312630P

P = Pneumatic contact control (optional)

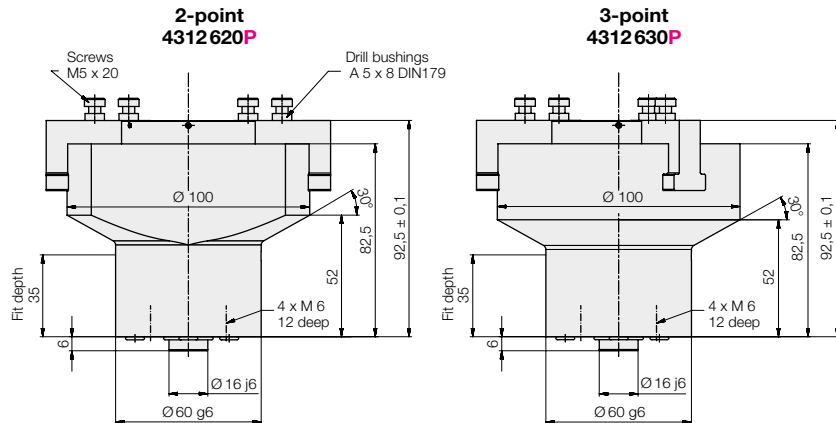

Admissible machining forces

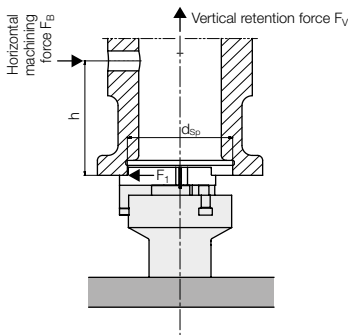

Included in our delivery:
 1 x O-ring 17.17 x 1.78 (3000663)
 3 x O-ring 5 x 1.5 (3000340)

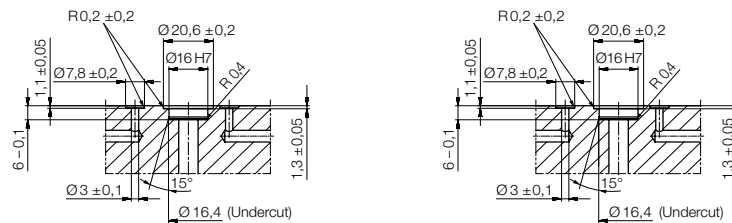

Vertical retention force

The concentric clamping element generates only horizontal clamping forces. Vertical (uplift) retention forces can only be transmitted non-positively by friction. The largest vertical retention force is

$$F_V = \mu \cdot F_{Sp} \quad [\text{kN}]$$

with $\mu \sim 0.2$: $F_V \sim 0.2 \cdot F_{Sp} \quad [\text{kN}]$

Admissible horizontal machining force

Depending on the height of attack of the machining force over the support surface, a tilting torque is generated and thus also a vertical uplift force, which has to be compensated non-positively by friction between the clamping jaw and the workpiece. In the most unfavourable angle position, the admissible machining force is

$$F_{\text{Badm}} \leq \frac{F_1 \cdot 0.75 \cdot d_{Sp} \cdot \mu}{h} \leq F_1 \quad [\text{kN}]$$

with $F_1 = 20 \cdot p$ and $\mu \sim 0.2$ results:

$$F_{\text{Badm}} \leq \frac{3 \cdot p \cdot d_{Sp}}{h} \leq F_1 \quad [\text{kN}]$$

- μ = Coefficient of friction between the clamping jaw and the workpiece [-]
- p = Operating pressure [bar]
- F_{Sp} = Total clamping force [kN]
- F_1 = Clamping force per jaw [kN]
- d_{Sp} = Clamping diameter [mm]
- h = Height of the machining force above the support surface [mm]

If the machining forces are higher, the workpiece can be supported on the side. The concentric clamping element can also be used to only centre a workpiece and to clamp with additional elements on external fixed points.

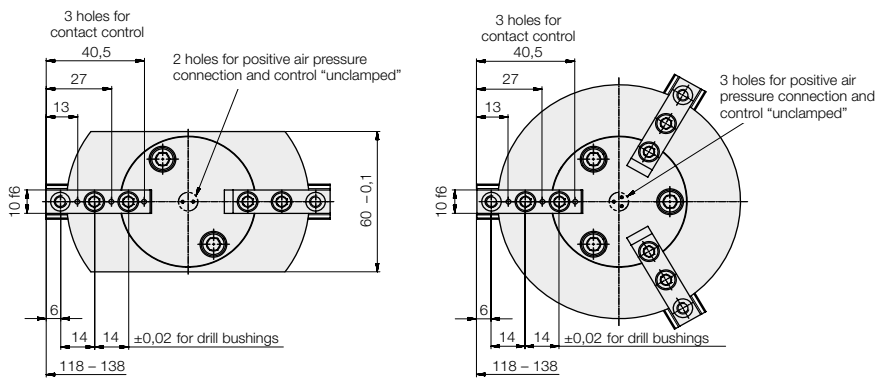

Connecting scheme

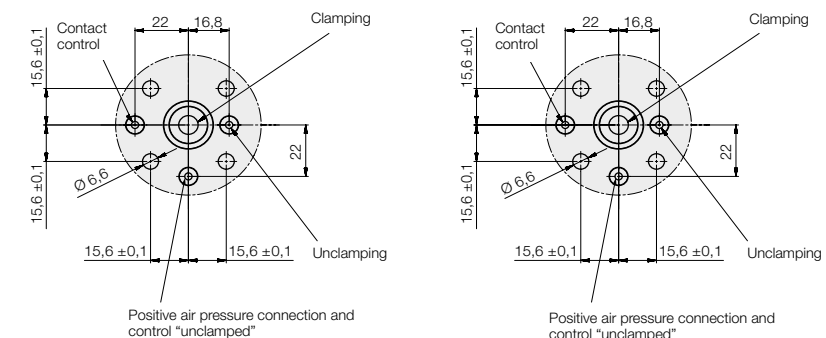

Examples for clamping jaws

Clamping jaws for manufacturing dimensions

for clamping $\varnothing 17 - 35$ mm (**4312620P**)

for clamping $\varnothing 103 - 121$ mm (**4312630P**)

