



ROEMHELD
HILMA ■ STARK

Issue 5-16 E

M 4.202

Lifting Module Shop-Floor Telescope

Max. lifting force 1,000 and 2,000 N, stroke from 300 to 1,000 mm, manual-hydraulic and electro-mechanical version



Advantages

- Low basic height
- Large strokes
- Simple and intuitive operation
- Working in ergonomically optimum height
- Sturdy industrial design
- Increase of quality in manufacturing and assembly processes
- Short amortisation time
- Increase of assembly throughput and productivity
- High level of safety against static overloads
- Checked in compliance with DIN EN 1570 with quadruple static overload

Application

Lifting module for workshop applications in the industry.

Principal use

- Industrial assembly working places
- Height adjustment of assembly working places in workshops
- Service
- Assembly fixtures
- Adjusting systems in supply processes of mid-sized objects
- Handling systems for product packing and transfer

Fixing and installation

For fixing of *modulog* modules or other components of the user at the top plate the lifting module has an interface 140 x 140.

For fixing of *modulog* modules at the bottom plate the lifting module has an interface 200 x 200. This plate can also be used to fix the lifting module on a flat level floor. For fixing 4 screws M10 of property class 10.9 as well as heavy-duty plugs are to be used.

For increased stability also a base plate, which can be delivered as accessory, can be fixed at the bottom plate.

Description

The lifting module Shop-Floor Telescope is particularly suitable for lifting and lowering assembly fixtures, working tables and demonstration objects in industrial applications as well as for medical treatment equipments in medical applications.

In general, lifting modules are used as base unit of devices for controlled lifting and lowering of loads or for height adjustment only. This version excels particularly by the low base height and the very high strokes.

Material

Lifting profile: aluminium, naturally anodised
Top and bottom plate: aluminium, black anodised

modulog Lifting module

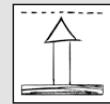

Part no. 8918-0X-X0-X

Technical characteristics

Max. lifting force: 1,000, 2,000 N
Max. bending moment: 500 Nm
Stroke: 300 up to 1,000 mm

Operations

- Foot pedal
- Foot switch
- Hand panel



Combinable with the modules

- Rotating modules - horizontal axis as per data sheet M 1.101 / M 1.201



- Rotating modules - vertical axis as per data sheet M 1.301



- Tilting modules as per data sheet M 2.101 / M 2.201



- Cart modules WMS as per data sheet M 5.101



- Floor modules FMS as per data sheet M 6.101
FMD as per data sheet M 6.201



modulog interfaces

- Top plate: 140 x 140 – Ø 10.5 mm
- Base plate: 200 x 200 – Ø 10.5 mm

Accessories

- Foot switch and hand panel as per data sheet M 8.200
- Extension cable as per data sheet M 8.200
- Electrical supply unit as per data sheet M 8.200
- Base and adaptor plates as per data sheet M 8.100 and M 8.110
- Table plates as per data sheet M 8.130 and M 8.131

Manual-hydraulic version operation with foot pedal



Description

The stroke movement is obtained by a hydraulic linear unit with single-lever actuation with oil being pumped by means of a piston pump into a plunger cylinder.

During retraction the oil returns due to the weight of the load from the cylinder back to the reservoir. A defined speed reduction is effected, independent of the load.

The manual-hydraulic variant is particularly sturdy and durable. This variant meets high safety demands and withstands jerking and knocking loads in applications.

According to the application 2 different force levels can be selected. The number of pump strokes depends on the force level.

Code for part numbers

Part no. 8918-0X-X0-H

Maximum lifting force

- 1 = 1,000 N
- 2 = 2,000 N

Stroke

- 3 = 300 mm
- 4 = 400 mm
- 6 = 600 mm
- 8 = 800 mm
- 10 = 1,000 mm

Dimensions

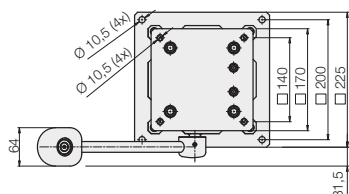
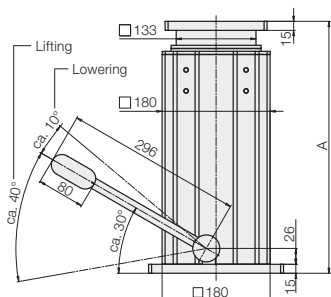

Operation

To lift the load, the foot pedal has to be depressed by approx. 40° several times. The pedal returns to its off-position by means of a return spring.

To lower the load, the foot pedal has to be moved upwards by approx. 10°.

Maximum lifting force and maximum admissible torque load

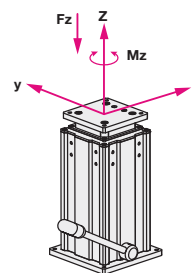

Stroke	A	A + stroke	Weight
[mm]	[mm]	[mm]	[kg]
300	420	720	15
400	470	870	20
600	570	1,170	25
800	670	1,470	30
1,000	770	1,770	35

Lifting force	Pump strokes per 100 mm	Descent speed
[N]		[mm/s]
1,000	2.2	approx. 90
2,000	3.5	approx. 60

Maximum lifting force F_z
Alternatively 1,000 N, 2,000 N

Maximum torque load:
Total M_x/y : 500 Nm
 M_z : 300 Nm

Accessories

Base plate for increased stability

Part no. 6311-412

See data sheet M 8.100

Important notes!

To descend the lifting module a minimum load of approx. 200 N is required.

The lifting module must only be pressure loaded. The centre of gravity should be within the traverse of the fixing screws. If the centre of gravity is outside, the dowelled joint with the floor has to be dimensioned correspondingly.

In such cases it is recommended to use a larger base plate.

In case of eccentric load of more than 250 mm, the column cannot descend automatically because of too high friction forces.

The lifting module is designed for applications within closed rooms.

In the case of eccentric loads, it is recommended to compensate these by counterweights. In off-position the indicated maximum torques may occur.

The forces and torques have to be considered by the operator. **During the lifting motion only 50 % of the maximum values are admitted.**

Electro-mechanical version Operation with foot switch or hand panel



Description

The lifting motion is generated by an electric motor with a spindle lifting gear. The electrically operated variant is particularly suitable for positioning and adjusting tasks of working tables as well as for material supply and transport. They excel by a smooth running.

Code for part numbers

Part no. 8918-0X-X0-E

Maximum lifting force

- 1 = 1,000 N
- 2 = 2,000 N

Stroke

- 3 = 300 mm
- 4 = 400 mm
- 6 = 600 mm
- 8 = 800 mm
- 10 = 1,000 mm

Dimensions

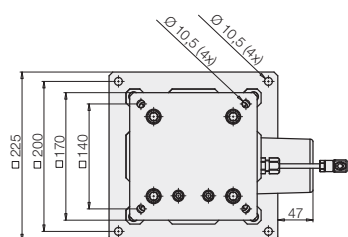
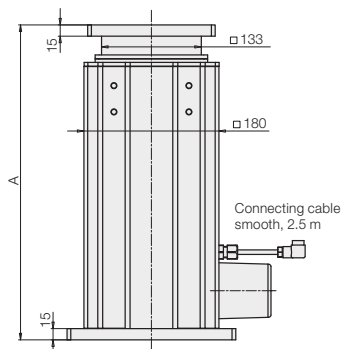

Accessories

Base plate for increased stability
Part no. 6311-412
See data sheet M 8.100

Operation

Lifting and lowering is triggered by push-buttons with touch control contact. After release of the push-button, the motion will be immediately stopped.

Technical characteristics

Electric connection	Plug
Duty cycle	15 % ED
Code class	IP 54
Control voltage	24 V DC

Lifting force	Lifting speed	Current consumption
[N]	[mm/s]	[A]
1,000	34 ... 30	6.5
2,000	18 ... 14	7.0

Maximum lifting force, maximum admissible torque load and important notes

As per manual-hydraulic version (see page 2).

Delivery

The lifting modules are delivered ready for connection. The connecting cable from the lifting module to the supply unit is included in the delivery. Foot switch or hand panel as well as supply units and a mains cable have to be ordered separately as accessory.

Electrical accessories

• **Foot switch**
with connecting cable 3.0 m
Part no. 3823-038



• **Hand panel**
with connecting cable 1.6 m
Part no. 3823-025



• **Supply unit**
with control
for one lifting module
Part no. 3821-246



• **Mains cable 230 VAC**
with earthing type plug for supply units
Mains cable smooth, 3.0 m
Part no. 3823-040

Further accessory
See data sheet M 8.200