

Electric Drives
and Controls

Hydraulics

Linear Motion and
Assembly Technologies

Pneumatics

Service

Rexroth
Bosch Group

3/2, 4/2 and 4/3 directional valves, internally pilot operated, externally pilot operated

RE 24851/08.08

1/36

Types WPH, WHH, WMMH, WMDH, WMDAH, WMRH and WMUH

Sizes 10 to 32
Component series 4X; 6X; 7X
Maximum operating pressure 350 bar [5076 psi]
Maximum flow 1100 l/min [290 US gpm]

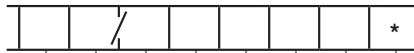

Table of contents

Content	Page
Features	1
Ordering code	2, 3
Spool symbols	4 to 7
Function, section	8, 9
Pilot oil supply	10, 11
Technical data	12, 13
Characteristic curves, performance limits	14 to 24
Unit dimensions	25 to 31
Stroke adjustment, mounting options	32, 33
Switching time adjustment	34
Pressure reducing valve "D3"	34
Pre-load valve	35

Features

- 7 types of actuation:
 - Pneumatic-hydraulic (type WPH)
 - Hydraulic-hydraulic (type WHH)
 - Hand lever (type WMMH)
 - Rotary knob (type WMDH)
 - Rotary knob, lockable (type WMDAH)
 - Roller plunger (type WMRH)
 - Roller plunger, rotated 90° (type WMUH)
- For subplate mounting
- Porting pattern to ISO 4401 and NFPA T3.5.1 R2-2002
- Subplates according to data sheets RE 45054 to RE 45060 (separate order), see page 30
- Spring centering, spring end position or hydraulic end position
- Manual override, optional
- Switching time adjustment, optional
- Pre-load valve in channel P of the main valve, optional
- Stroke adjustment of main spool, optional
- Stroke adjustment and/or end position check, optional
- Inductive position switches and proximity sensors (contactless), see RE 24830



Further details in clear text

Seal material

NBR seals
FKM seals
(other seals on request)

⚠ Attention!

Observe compatibility of seals with hydraulic fluid used!

No code =

V =

Without pressure reducing valve

With pressure reducing valve

No code =

D3⁴⁾ =

Pre-load valve (not for NG10)⁴⁾

Without pre-load valve

With pre-load valve ($p_0 = 4.5 \text{ bar}$ [65 psi])

No code =

P4,5 =

Throttle insert

Without throttle insert

Throttle Ø 0.8 mm [0.0315 inch]

Throttle Ø 1.0 mm [0.0394 inch]

Throttle Ø 1.2 mm [0.0472 inch]

Throttle Ø 1.5 mm [0.0591 inch]

Throttle Ø 2.0 mm [0.0787 inch]

Throttle Ø 2.5 mm [0.0984 inch]

No code =

B08 =

B10 =

B12 =

B15 =

B20 =

B25 =

Stroke adjustment

For ordering code, see pages 32 and 33

Spool position monitoring

Without position switches

Monitored spool position "a"

Monitored spool position "b"

Monitored spool positions "a" and "b"

Monitored rest position

For further details, see RE 24830

No code =

QMAG24 =

QMBG24 =

QMABG24 =

QM0G24 =

No code =

S =

S2 =

Without switching time adjustment

Switching time adjustment as meter-in control

Switching time adjustment as meter-out control

- 1) Pilot oil supply X or drain Y **external**:
- For NG10, version SO30 must be provided for the use of sandwich plates. Code SO30 must be added at the end of the type designation (sandwich plate).
 - The adherence to the permissible maximum operating parameters of the pilot valve (see RE 22280 and RE 22282) must be ensured!
 - Maximum pilot pressure: please read page 12!
- 2) Pilot oil supply **internal** (versions "ET" and "E"):
- Minimum pilot pressure: please read page 13!
 - To prevent impermissibly high pressure peaks, a **throttle insert "B10"** must be provided in the P port of the pilot valve (see page 11).
 - In conjunction with version "H-" **pressure reducing valve "D3"** must be provided additionally.

3) 2 spool positions (hydraulic end position): only spools C, D, Y, K, Z

4) Only in conjunction with throttle insert "B10"

Spool symbols: 2 spool positions

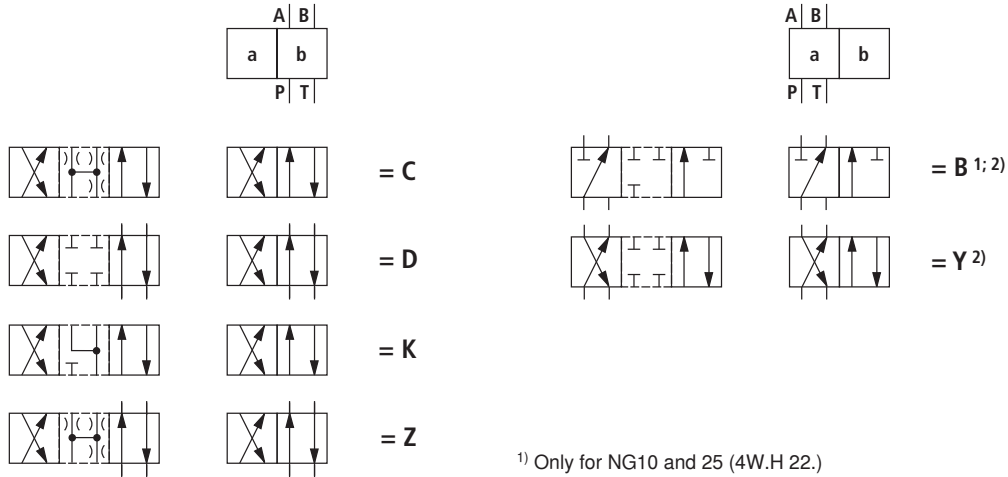

- ¹⁾ Only for NG10 and 25 (4W.H 22.)
If operating pressure > tank pressure, port T must be used as leakage port!
- ²⁾ Only types WMRH/WMUH and WMMH available.

⚠ Attention!
Caution in conjunction with single-rod cylinders due to pressure intensification!

Ordering code		Type of actuation	
Spool symbol	Spool return	Hydraulic Type WHH	Pneumatic Type WPH
C, D, K, Z	.../...		
	..H../O		
	..H../OF		
B, Y	.../...		
Y	..H../...		

Spool symbols: 2 spool positions

Ordering code		Type of actuation	
Spool symbol	Spool return	Hand lever Type WMMH	Rotary knob Types WMDH, WMDAH
C, D, K, Z	..H../F		
B, Y			
Y	..H../F		

Ordering code		Type of actuation
Spool symbol	Spool return	Roller plunger Types WMRH, WМУH
C, D, K, Z		
B, Y		

Spool symbols: 3 spool positions

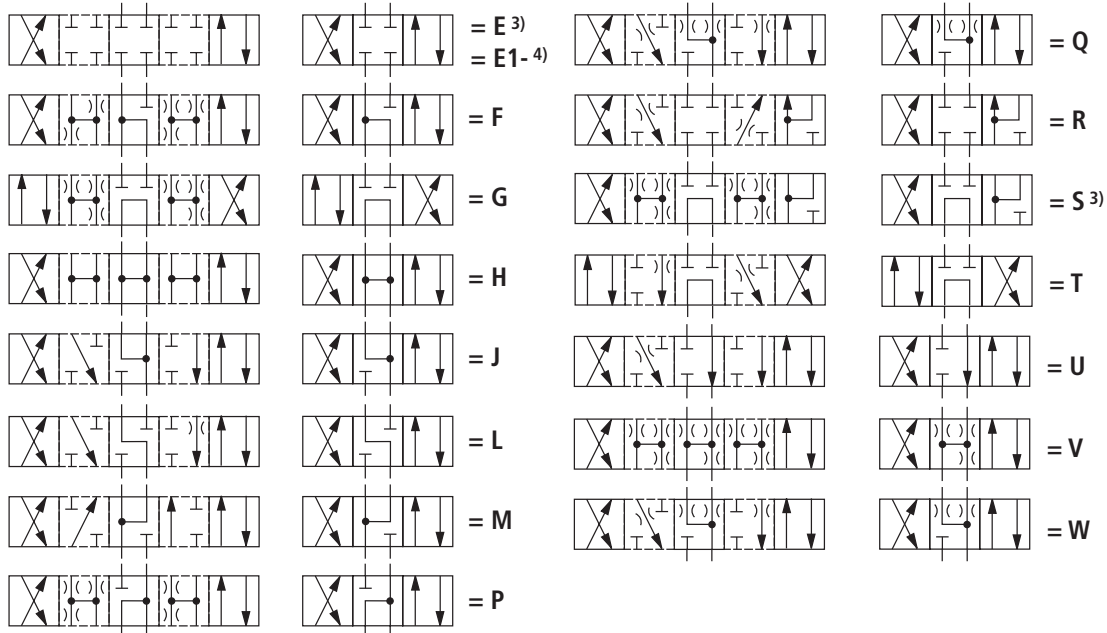

³⁾ **Example:**

- Spool E with actuation side "a" → ordering code ..EA..
- Spool E with actuation side "b" → ordering code ..EB..

⁴⁾ Spool symbol E1-: P → A/B pre-opening

⁵⁾ Only on NG16

⚠ Attention!

Caution in conjunction with single-rod cylinders due to pressure intensification!

Ordering code			Type of actuation	
Spool symbol	Actuation side	Spool return	Hydraulic Type WHH	Pneumatic Type WPH
E, F, G, H, J, L, M, Q, R, S, T, U, V, W	.A			
	.B			

Spool symbols: 3 spool positions

Ordering code			Type of actuation	
Spool symbol	Ac-tuation side	Spool return	Hand lever Type WMMH	Rotary knob Types WMDH, WMDAH
E, E1-, F, G, H, J, L, M, Q, R, S, T, U, V, W	.A	..H../F		
	.B	..H../F		
		..H../F		

Ordering code			Type of actuation
Spool symbol	Ac-tuation side	Spool return	Roller plunger Types WMRH, WМУH
E, E1-, F, G, H, J, L, M, Q, R, S, T, U, V, W			

Function, section: Types WPH and WHH

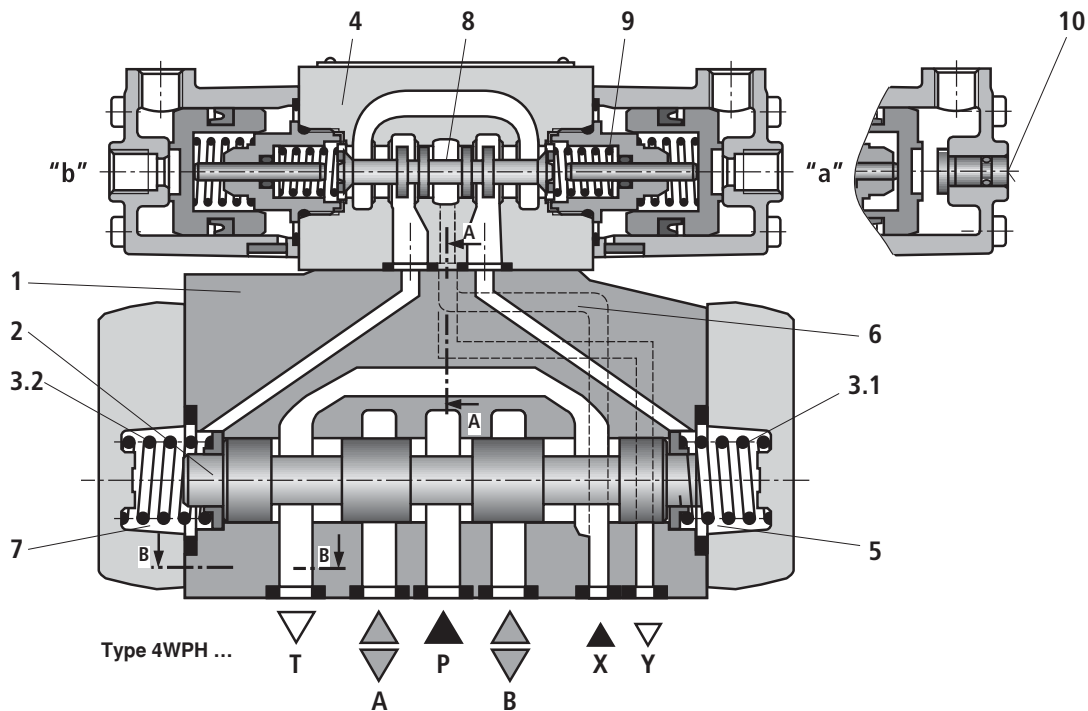

Directional valves Type WPH and WHH

Valves of type WPH are directional spool valves with pneumatic-hydraulic actuation, type WHH with hydraulic-hydraulic actuation. They control the start, stop and direction of a flow.

These directional valves basically consist of the main valve with housing (1), main control spool (2), one or two return springs (3.1) and (3.2), as well as pilot valve (4).

Main control spool (2) in the main valve is held in the zero or initial position by springs or through pressurization. In the initial position, the two spring chambers (5) and (7) are connected via pilot valve (4) pressureless to the tank. Pilot valve (4) is supplied with pilot oil via pilot channel (6). The supply can be provided internally or externally (externally via port X).

When the pilot valve is operated, e.g. side "a", pilot spool (8) is pushed to the left, and spring chamber (7) is consequently pressurized to pilot pressure. Spring chamber (5) remains pressureless.

The pilot pressure acts on the left side of main control spool (2) and pushes it against spring (3.1). As a result, port P is connected to B, and A to T in the main valve.

In the non-operated condition, control spool (8) is held by return spring (9) in the central or initial position (except for impulse spool). Spring chamber (7) is unloaded to the tank.

The pilot oil is displaced from the spring chamber via pilot valve (4) into channel Y.

The pilot oil is supplied and drained internally or externally (externally via port Y).

An optional manual override (10) allows pilot spool (8) to be moved (8) without pneumatic pressure (type WPH only).

Note!

Return springs (3.1) and (3.2) in spring chambers (5) and (7) hold main control spool (2) in the central position without pilot pressure, also in the case of, for example, a vertical valve arrangement.

Pilot valve for type WHH, see RE 22282.

Pilot oil supply (sections A – A and B – B), see pages 10 and 11.

Function, section: Type WM.H

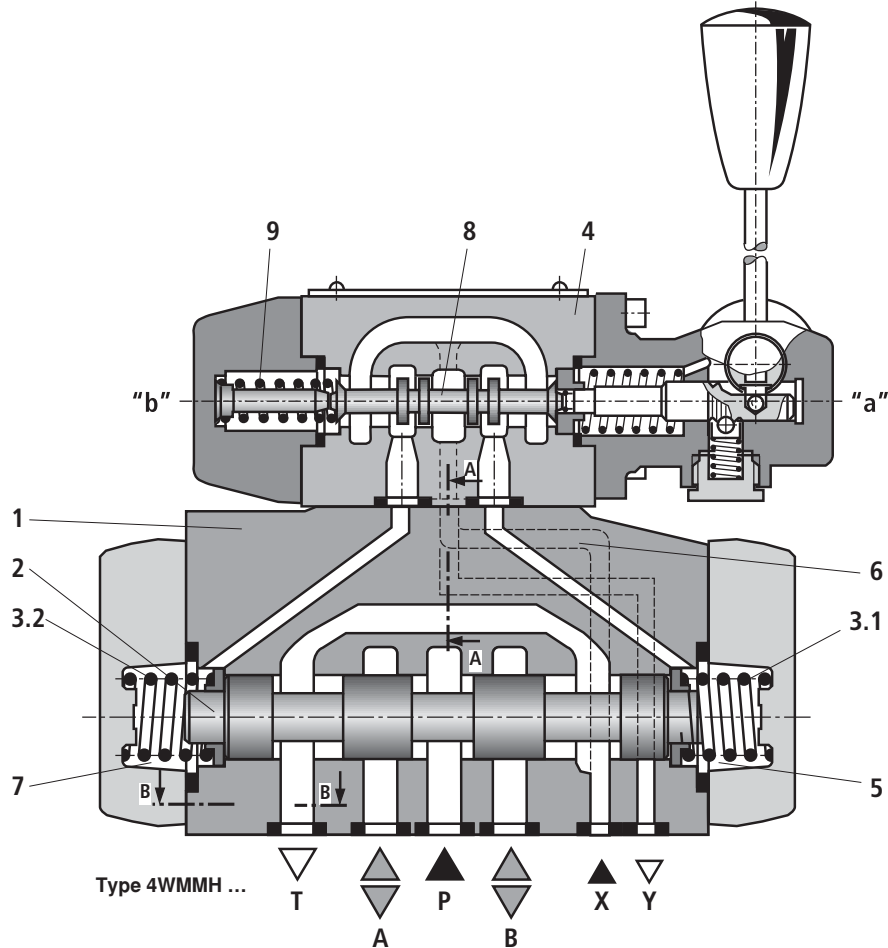

Directional valves of type WM.H

Valves of type WM.H are directional spool valves with mechanical-hydraulic actuation. They control the start, stop and direction of a flow.

These directional valves basically consist of the main valve with housing (1), main control spool (2), one or two return springs (3.1) and (3.2), as well as the pilot valve (4).

The function of these valves corresponds to that of type WPH. The pilot valve is, however, actuated mechanically.

For pilot valves for types WMDH, WMDAH, WMRH, WМУH, see RE 22280.

Pilot oil supply (sections A – A and B – B), see pages 10 and 11.

Pilot oil supply

NG10

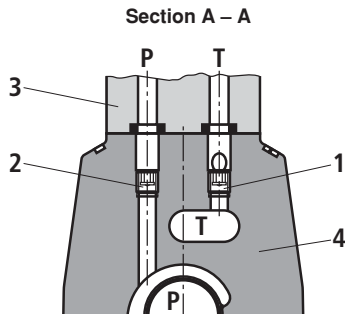

NG16

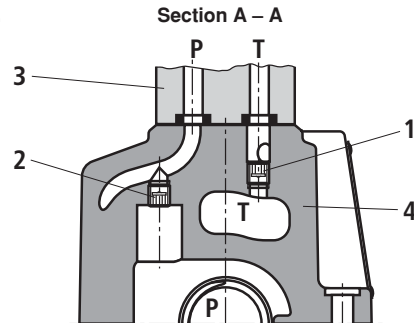

NG25 (type 4W.H 22 .7X/...)

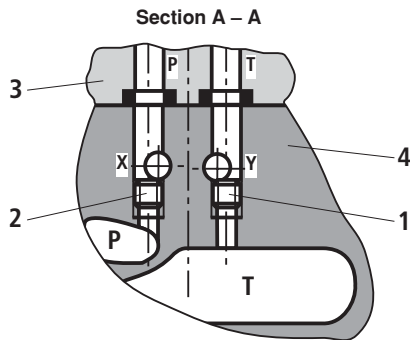

NG25 (type 4W.H 25 .6X/...)

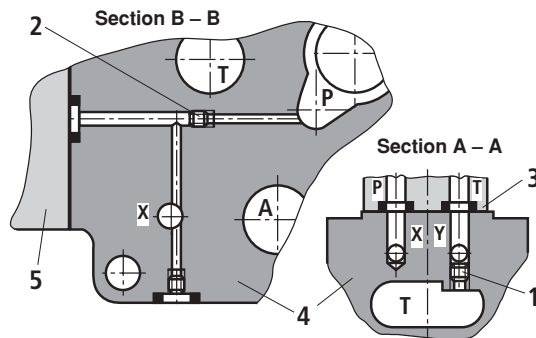

NG32

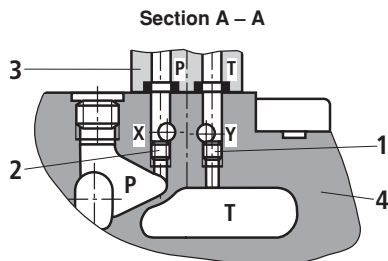

Pilot oil supply

External: 2 closed
Internal: 2 open

Pilot oil drain

External: 1 closed
Internal: 1 open

For further details and explanations of items, see next page.

Pilot oil supply

Type 4W.H...

The pilot oil is supplied **externally** - via channel X - from a separate circuit.

The pilot oil is drained **externally** - via channel Y - into the tank.

Type 4W.H...E...

The pilot oil is supplied **internally** from channel P of the main valve (see also page 13, footnotes ⁶⁾ and ⁷⁾)

The pilot oil is drained **externally** - via channel Y - into the tank. Port X in the subplate must be plugged.

Type 4W.H...ET...

The pilot oil is supplied **internally** from channel P of the main valve.

The pilot oil is drained **internally** - via channel T - into the tank. Ports X and Y in the subplate must be plugged.

Type 4W.H...T...

The pilot oil is supplied **externally** - via channel X - from a separate circuit.

The pilot oil is drained **internally** - via channel T - into the tank. Port Y in the subplate must be plugged.

- 1 Plug screw M6, 3 A/F
– Pilot oil drain
- 2 Plug screw M6, 3 A/F
– Pilot oil supply
- 3 Pilot valve
- 4 Main valve
- 5 Cover
- 6 Throttle insert

Tightening torques M_T for cover mounting screws:

NG16: 35 Nm [25.8 ft-lbs] ±10%;

NG25: 68 Nm [50.2 ft-lbs] ±10%

Tightening torques M_T for mounting screws for the pilot valve: **NG10 to 32:** 9 Nm [6.6 ft-lbs] ±10%

Throttle insert

The use of throttle insert (6) is required, if the pilot oil supply is to be limited in channel P of the pilot valve (see below).

Throttle insert (6) is to be installed in channel P of the pilot valve.

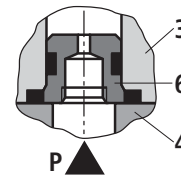

⚠ Attention!

The pilot oil supply may exclusively be modified by authorized specialists or in the factory!

– Pilot oil supply X or drain Y **external**:

- For NG10, version SO30 must be provided for the use of sandwich plates. Code SO30 must be added at the end of the type designation (sandwich plate).
- The adherence to the permissible maximum operating parameters must be ensured (see RE 22280 and RE 22282)!
- Maximum pilot pressure: please read page 12!

– Pilot oil supply **internal** (version "ET" and "E"):

- Minimum pilot pressure: please read page 13!
- To prevent impermissibly high pressure peaks, a **throttle insert "B10"** must be provided in the P port of the pilot valve (see above).
- In conjunction with version "H-" **pressure reducing valve "D3"** (see page 34) must be provided additionally.

Technical data (for applications outside these parameters, please consult us!)

General

Sizes	NG	10	16	25 4W.H 22	25 4W.H 25	32	
Weight, ca.	– Type WPH 2 spool positions	kg [lbs]	6.8 [15.0]	8.9 [19.6]	11.9 [26.2]	18.0 [39.7]	18.0 [39.7]
		3 spool positions	kg [lbs]	7.6 [16.8]	9.7 [21.4]	12.7 [28.0]	19.8 [43.7]
	– Type WHH 2 spool positions	kg [lbs]	6.9 [15.2]	9.0 [19.8]	12.0 [26.5]	18.1 [39.9]	18.1 [39.9]
		3 spool positions	kg [lbs]	6.8 [15.0]	8.9 [19.6]	11.9 [26.2]	19.0 [41.9]
	– Types WMMH, WMDH, WMDAH, WMRH and WMUH	kg [lbs]	6.4 [14.1]	8.5 [18.7]	11.5 [25.3]	17.6 [38.8]	17.6 [38.8]
	– Switching time adjustment	kg [lbs]	0.8 [1.8]	0.8 [1.8]	0.8 [1.8]	0.8 [1.8]	0.8 [1.8]
– Pressure reducing valve	kg [lbs]	0.4 [0.9]	0.4 [0.9]	0.4 [0.9]	0.4 [0.9]	0.4 [0.9]	
Installation position	Optional; vertical in the case of valves with hydraulic spool return "H" and spool symbols B, C, D, K, Z, Y						
Ambient temperature range	°C [°F]	–30 to +50 [–22 to +122]					
Storage temperature range	°C [°F]	–20 to +70 [–4 to +158]					
Surface protection (valve body)	Paint coating, layer thickness max. 100 µm						

Hydraulic

Maximum operating pressure								
– Ports P, A, B	Type 4W.H	bar [psi]	280 [4061]	280 [4061]	280 [4061]	280 [4061]	280 [4061]	
	Type H-4W.H	bar [psi]	350 [5076]	350 [5076]	350 [5076]	350 [5076]	350 [5076]	
– Port T	Pilot oil drain Y external	Type 4W.H	bar [psi]	280 [4061]	250 [3626]	250 [3626]	250 [3626]	250 [3626]
		Type H-4W.H		315 [4568]	250 [3626]	250 [3626]	250 [3626]	250 [3626]
	Pilot oil drain Y internal ¹⁾	bar [psi]	160 [2321]; 60 [870] with types WMRH and WMUH					
– Port Y	Pilot oil drain external	bar [psi]	160 [2321]; 60 [870] with types WMRH and WMUH					
Hydraulic fluid	Mineral oil (HL, HLP) to DIN 51524 ¹⁾ ; fast bio-degradable hydraulic fluids to VDMA 24568 (see also RE 90221); HETG (rape seed oil) ¹⁾ ; HEPG (polyglycols) ²⁾ ; HEES (synthetic esters) ²⁾ ; other hydraulic fluids on request							
Hydraulic fluid temperature range	°C [°F]	–30 to +80 [–22 to +176] (NBR seals) –20 to +80 [–4 to +176] (FKM seals)						
Viscosity range	mm ² /s [SUS]	2.8 to 500 [35 to 2320]						
Permissible max. degree of contamination of the hydraulic fluid - cleanliness class to ISO 4406 (c)	Class 20/18/15 ⁴⁾							
Maximum pilot pressure ³⁾	bar [psi]	250 [3626]	250 [3626]	210 [3046]	250 [3626]	250 [3626]		

Technical data (for applications outside these parameters, please consult us!)

Hydraulic

Size	NG	10	16	25 4W.H 22	25 4W.H 25	32	
Minimum pilot pressure (see also characteristic curves on page 14)							
– Pilot oil supply X external, pilot oil supply X internal (with spools: D, K, E, J, L, M, Q, R, U, W)							
3-spool-position valve, spring-centered	Type H-4W.H...	bar [psi]	10 [145]	14 [203]	12.5 [181]	13 [188]	8.5 [123]
	Type 4W.H...	bar [psi]	10 [145]	14 [203]	10.5 [152]	13 [188]	8.5 [123]
3-spool-position valve, pressure-centered		bar [psi]	–	14 [203]	–	18 [261]	8.5 [123]
2-spool-position valve with spring end position	Type H-4W.H...	bar [psi]	10 [145]	14 [203]	14 [203]	13 [188]	10 [145]
	Type 4W.H...	bar [psi]	10 [145]	14 [203]	11 [159]	13 [188]	10 [145]
2-spool-position valve with hydraulic end position		bar [psi]	7 [101]	14 [203]	8 [116]	8 [116]	5 [72]
– Pilot oil supply X internal (with spools C, F, G, H, P, T, V, Z, S ⁵⁾)		bar [psi]	4.5 [65] ⁶⁾	4.5 [65] ⁷⁾	4.5 [65] ⁷⁾	4.5 [65] ⁷⁾	4.5 [65] ⁷⁾
Pilot volume for switching process							
– 3-spool-position valve, spring-centered	cm ³ [inch ³]		2.04 [0.124]	5.72 [0.349]	7.64 [0.466]	14.2 [0.866]	29.4 [1.794]
– 2-spool-position valve	cm ³ [inch ³]		4.08 [0.249]	11.45 [0.699]	15.28 [0.932]	28.4 [1.733]	58.8 [3.588]
from spool position "a" to zero position	cm ³ [inch ³]		–	2.9 [0.177]	–	7.0 [0.427]	15.1 [0.921]
from zero position to spool position "b"	cm ³ [inch ³]		–	5.72 [0.349]	–	14.15 [0.863]	29.4 [1.794]
from spool position "b" to zero position	cm ³ [inch ³]		–	2.83 [0.173]	–	5.73 [0.349]	14.4 [0.879]
Pilot flow for shortest switching time, ca.	l/min [US gpm]		35 [9.2]	35 [9.2]	35 [9.2]	35 [9.2]	45 [11.9]

¹⁾ Suitable for NBR **and** FKM seals

²⁾ Suitable **only** for FKM seals

³⁾ – Pilot oil supply **internal**:

- In the case of higher pilot pressure, a pressure reducing valve must be used.
- In conjunction with version "H-" **pressure reducing valve "D3"** must be provided additionally. (If it is not used, pilot pressure = operating pressure at the port)

– Pilot oil supply **external**:

- In conjunction with version "H-" the adherence to the maximum pilot pressure must be ensured by taking suitable measures (e.g. protection of the separate pilot oil circuit through the use of a pressure relief valve)!

⁴⁾ The cleanliness classes specified for components must be adhered to in hydraulic systems. Effective filtration prevents malfunction and, at the same time, prolongs the service life of components.

For the selection of filters, see data sheets RE 50070, RE 50076, RE 50081, RE 50086, RE 50087 and RE 50088.

⁵⁾ Spool S for NG16 only

⁶⁾ With symbols C, F, G, H, P, T, V, Z, internal pilot oil supply is only possible, if in the central position (in the case of 3-spool-position valve) or while passing the central position (in the case of 2-spool-position valve) the flow from P to T is so large that the pressure differential from P to T reaches a value of at least 6.5 bar [94 psi].

⁷⁾ For spools C, F, G, J, H, P, T, V, Z, S⁵⁾ – through pre-load valve (not for size NG10) or correspondingly large flow. (For the establishment of the required flow, see characteristic curves "pre-load valve", page 35.)

Free flow cross-sections in zero position with spools Q, V and W

Size		NG	10	16	25 4W.H 22	25 4W.H 25	32
Spool Q	A - T; B - T	mm ² [inch ²]	13 [0.02]	32 [0.05]	78 [0.121]	83 [0.129]	78 [0.121]
Spool V	P - A; P - B	mm ² [inch ²]	13 [0.02]	32 [0.05]	73 [0.113]	83 [0.129]	73 [0.113]
	A - T; B - T	mm ² [inch ²]	13 [0.02]	32 [0.05]	84 [0.13]	83 [0.129]	84 [0.13]
Spool W	A - T; B - T	mm ² [inch ²]	2.4 [0.004]	6 [0.009]	10 [0.015]	14 [0.022]	20 [0.031]

Characteristic curves (measured with HLP46, $\vartheta_{oil} = 40 \text{ } ^\circ\text{C} \pm 5 \text{ } ^\circ\text{C}$ [104 °F ± 9 °F])

Minimum pilot pressure in dependence upon tank pressure (type WPH)

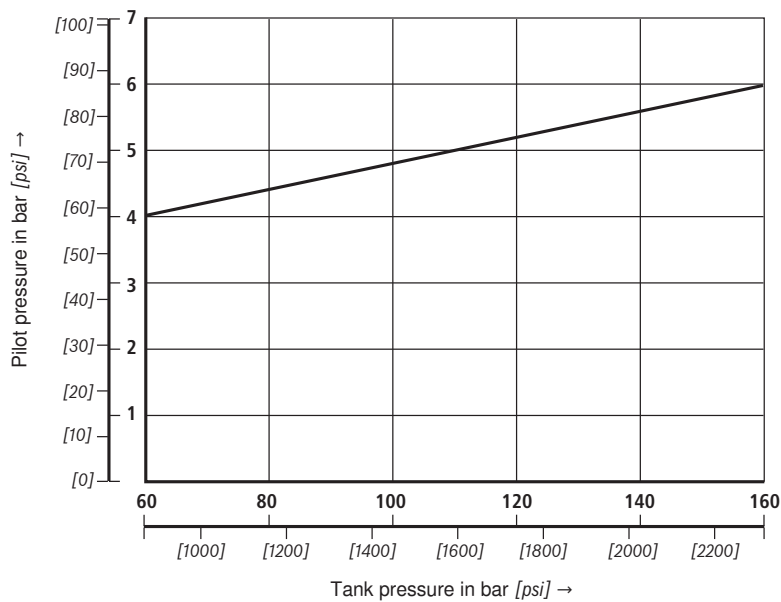

In the case of a higher tank pressure, the minimum pilot pressure must be raised in accordance with this diagram.

Minimum pilot pressure in dependence upon tank pressure (type WHH):

$p_{St \min} > 6 \text{ to } 10 \text{ bar}$ [87 to 145 psi] > tank pressure

Characteristic curves: NG10 (measured with HLP46, $\vartheta_{oil} = 40\text{ °C} \pm 5\text{ °C}$ [104 °F \pm 9 °F])

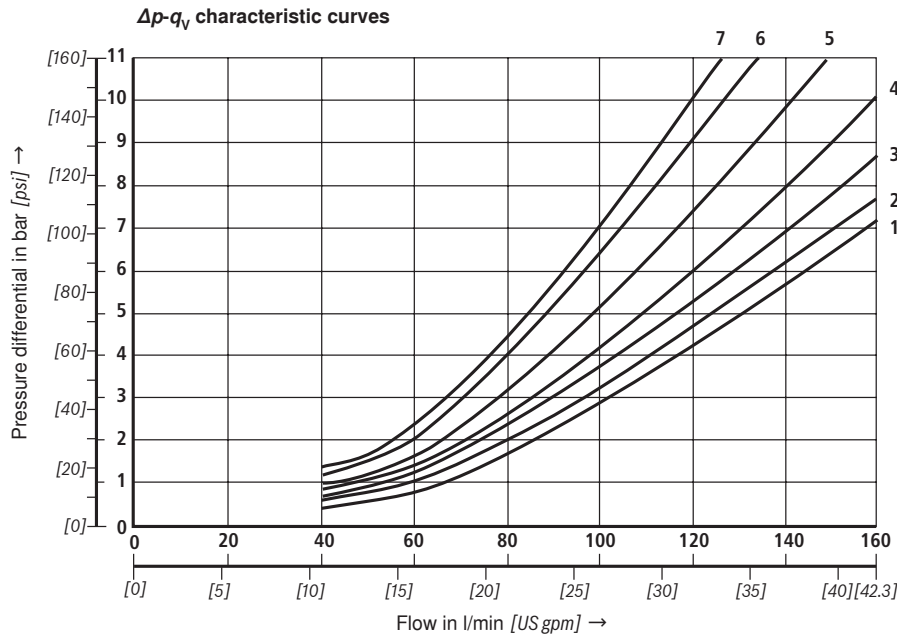

Spool	Spool position				Spool	Zero position		
	P - A	P - B	A - T	B - T		A - T	B - T	P - T
E, Y, D	2	2	4	5				
F	1	4	1	4	F	3	-	6
G, T	4	2	2	6	G, T	-	-	7
H, C	4	4	1	4	H	1	3	5
J, K	1	2	1	3				
L	2	3	1	4	L	3	-	-
M	4	4	3	4				
P	4	1	3	4	P	-	7	5
Q, V, W, Z	2	2	3	5				
R	2	2	3	-				
U	3	3	3	4	U	-	4	-
B	2	2	-	-				

Performance limits: NG10 (measured with HLP46, $\vartheta_{oil} = 40\text{ °C} \pm 5\text{ °C}$ [104 °F \pm 9 °F])

2-spool-position valves - $q_{V\max}$ in l/min [US gpm]

Spool	Operating pressure p_{\max} in bar [psi]		
	200 [2900]	250 [3626]	315 [4568]
E, J, L, M, Q, R, U, V, W, C, D, K, Z, Y	160 [42]	160 [42]	160 [42]
H	160 [42]	150 [39]	120 [32]
G, T	160 [42]	160 [42]	140 [37]
F, P	160 [42]	140 [37]	120 [32]

⚠ Attention!
Important notes on page 24!

Characteristic curves: NG16 (measured with HLP46, $\vartheta_{oil} = 40 \text{ }^\circ\text{C} \pm 5 \text{ }^\circ\text{C}$ [104 °F \pm 9 °F])

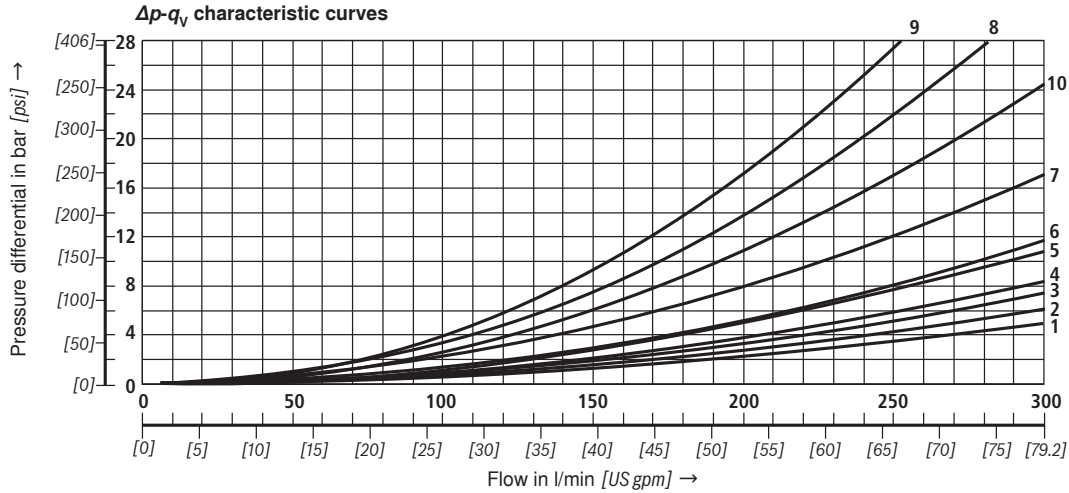

Spool	Spool position				Zero position		
	P-A	P-B	A-T	B-T	P-T	A-T	B-T
D, E	1	1	3	3			
F	1	2	5	5	4	3	-
G	4	1	5	5	7	-	-
C, H	1	1	5	6	2	4	4
K, J	2	2	6	6	-	3	-
L	2	2	5	4	-	3	-
M	1	1	3	4			
P	2	1	3	6	5	-	-

Spool	Spool position				Zero position		
	P-A	P-B	A-T	B-T	P-T	A-T	B-T
Q	1	1	6	6			
R	2	4	7	-			
S	3	3	3	-	9	-	-
T	4	1	5	5	7	-	-
U	2	2	3	6			
V, Z	1	1	6	6	10	8	8
W	1	1	3	4			

Performance limits: NG16 (measured with HLP46, $\vartheta_{oil} = 40 \text{ °C} \pm 5 \text{ °C}$ [$104 \text{ °F} \pm 9 \text{ °F}$])

2-spool-position valves – $q_{V \max}$ in l/min [US gpm]

Spool	Operating pressure p_{\max} in bar [psi]				
	70 [1015]	140 [2030]	210 [3046]	280 [4061]	350 [5076]

X external – spring end position in main valve
(at $p_{St \min} = 12 \text{ bar}$ [174 psi])

C, D, K, Y, Z	300 [79]	300 [79]	300 [79]	300 [79]	300 [79]
---------------	----------	----------	----------	----------	----------

X external – spring end position in main valve ¹⁾

C	300 [79]	300 [79]	300 [79]	300 [79]	300 [79]
D, Y	300 [79]	270 [71]	260 [68]	250 [66]	230 [60]
K	300 [79]	250 [66]	240 [63]	230 [60]	210 [55]
Z	300 [79]	260 [68]	190 [50]	180 [47]	160 [42]

X external – hydraulic end position in main valve

HC, HD, HK, HZ, HY	300 [79]	300 [79]	300 [79]	300 [79]	300 [79]
--------------------	----------	----------	----------	----------	----------

3-spool-position valves – $q_{V \max}$ in l/min [US gpm]

Spool	Operating pressure p_{\max} in bar [psi]				
	70 [1015]	140 [2030]	210 [3046]	280 [4061]	350 [5076]

X external – spring-centered

E, H, J, L, M, Q, U, W, R	300 [79]	300 [79]	300 [79]	300 [79]	300 [79]
---------------------------	----------	----------	----------	----------	----------

F, P	300 [79]	250 [66]	180 [47]	170 [45]	150 [39]
------	----------	----------	----------	----------	----------

G, T	300 [79]	300 [79]	240 [63]	210 [55]	190 [50]
------	----------	----------	----------	----------	----------

S	300 [79]	300 [79]	300 [79]	250 [66]	220 [58]
---	----------	----------	----------	----------	----------

V	300 [79]	250 [66]	210 [55]	200 [53]	180 [47]
---	----------	----------	----------	----------	----------

X external – pressure-centered

(at minimum pilot pressure von 16 bar [232 psi])

All spools ²⁾	300 [79]	300 [79]	300 [79]	300 [79]	300 [79]
--------------------------	----------	----------	----------	----------	----------

⚠ Attention!

¹⁾ When the specified flow values are exceeded, the function of the return spring can no longer be guaranteed in the event of a pilot pressure failure!

²⁾ With spool V, a pilot valve is not required in the case of flows > 160 l/min [42 US gpm].

For further important notes, see page 24!

Characteristic curves: NG25 (type W.H 22)
(measured with HLP46, $\vartheta_{oil} = 40 \text{ }^\circ\text{C} \pm 5 \text{ }^\circ\text{C}$ [104 °F \pm 9 °F])

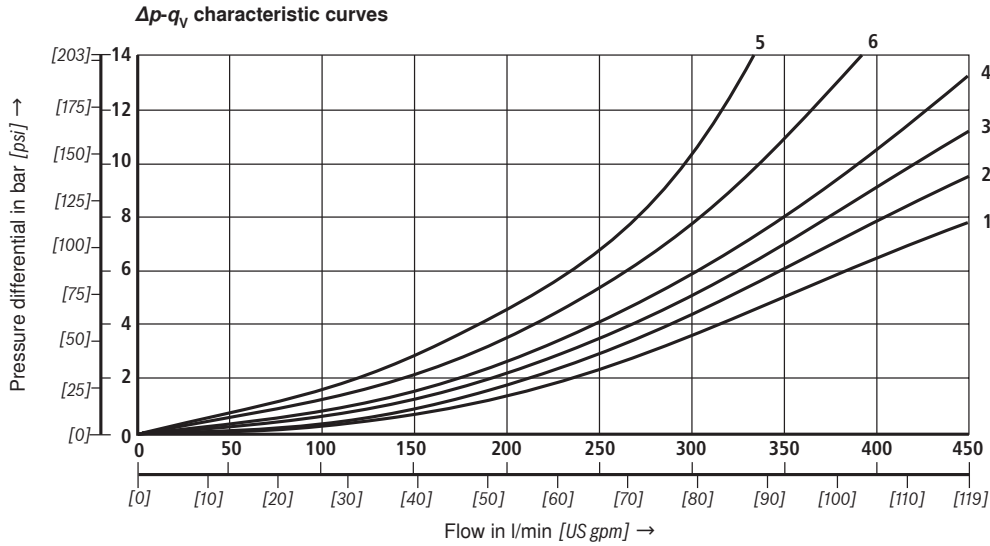

Spool	Spool position				
	P - A	P - B	A - T	B - T	B - A
C, E, M, P, Q, U, V, Z	2	2	1	4	-
F	1	2	1	2	-
G, T	2	2	2	4	-
H, J, W, K, D	2	2	1	3	-
L	2	2	1	2	-
R	1	2	1	-	5
B	2	2	-	-	-

Spool	Zero position		
	A - T	B - T	P - T
F	-	-	4
G, P	-	-	6
H	-	-	2
L	4	-	-
T	-	-	5
U	-	6	-

Performance limits: NG25 (type W.H 22)
(measured with HLP46, $\vartheta_{oil} = 40 \text{ °C} \pm 5 \text{ °C}$ [$104 \text{ °F} \pm 9 \text{ °F}$])

2-spool-position valves – $q_{V \max}$ in l/min [US gpm]

Spool	Operating pressure p_{\max} in bar [psi]				
	70 [1015]	140 [2030]	210 [3046]	280 [4061]	350 [5076]

X external – spring end position in main valve
(at $p_{St \min} = 11 \text{ bar} / 14 \text{ bar}$ [159/203 psi])

Spool	70 [119]	140 [119]	210 [119]	280 [119]	350 [119]
C, D, K, Y, Z	450	450	450	450	450

X external – spring end position in main valve ¹⁾

Spool	70 [119]	140 [119]	210 [84]	280 [66]	350 [53]
C	450	450	320	250	200

Spool	70 [119]	140 [119]	210 [119]	280 [105]	350 [84]
D, Y	450	450	450	400	320

Spool	70 [119]	140 [57]	210 [39]	280 [32]	350 [26]
K	450	215	150	120	100

Spool	70 [92]	140 [79]	210 [76]	280 [68]	350 [42]
Z	350	300	290	260	160

X external – hydraulic end position in main valve

Spool	70 [119]	140 [119]	210 [119]	280 [119]	350 [119]
HC, HD, HK, HZ, HY	450	450	450	450	450

Spool	70 [119]	140 [119]	210 [119]	280 [119]	350 [119]
HC./O..., HD./O..., HK./O..., HZ./O...	450	450	450	450	450

Spool	70 [119]	140 [119]	210 [119]	280 [119]	350 [119]
HC./OF..., HD./OF..., HK./OF..., HZ./OF...	450	450	450	450	450

Spool	70 [119]	140 [119]	210 [119]	280 [119]	350 [119]
HC./F..., HD./F..., HK./F..., HZ./F...	450	450	450	450	450

Spool	70 [119]	140 [119]	210 [119]	280 [119]	350 [119]
HC./F..., HD./F..., HK./F..., HZ./F...	450	450	450	450	450

Spool	70 [119]	140 [119]	210 [119]	280 [119]	350 [119]
HC./F..., HD./F..., HK./F..., HZ./F...	450	450	450	450	450

Spool	70 [119]	140 [119]	210 [119]	280 [119]	350 [119]
HC./F..., HD./F..., HK./F..., HZ./F...	450	450	450	450	450

3-spool-position valves – $q_{V \max}$ in l/min [US gpm]

Spool	Operating pressure p_{\max} in bar [psi]				
	70 [1015]	140 [2030]	210 [3046]	280 [4061]	350 [5076]

X external – spring-centered

Spool	70 [119]	140 [119]	210 [119]	280 [119]	350 [119]
E, J, L, M, Q, U, W, R	450	450	450	450	450

Spool	70 [119]	140 [119]	210 [79]	280 [68]	350 [61]
H	450	450	300	260	230

Spool	70 [105]	140 [92]	210 [66]	280 [53]	350 [47]
G	400	350	250	200	180

Spool	70 [119]	140 [71]	210 [46]	280 [34]	350 [29]
F	450	270	175	130	110

Spool	70 [119]	140 [79]	210 [63]	280 [58]	350 [42]
V	450	300	240	220	160

Spool	70 [105]	140 [79]	210 [63]	280 [53]	350 [42]
T	400	300	240	200	160

Spool	70 [119]	140 [71]	210 [47]	280 [45]	350 [29]
P	450	270	180	170	110

⚠ Attention!

¹⁾ When the specified flow values are exceeded, the function of the return spring can no longer be guaranteed in the event of a pilot pressure failure!

For further important notes, see page 24!

Characteristic curves: NG25 (type W.H 25)
(measured with HLP46, $\vartheta_{oil} = 40 \text{ }^\circ\text{C} \pm 5 \text{ }^\circ\text{C}$ [104 °F \pm 9 °F])

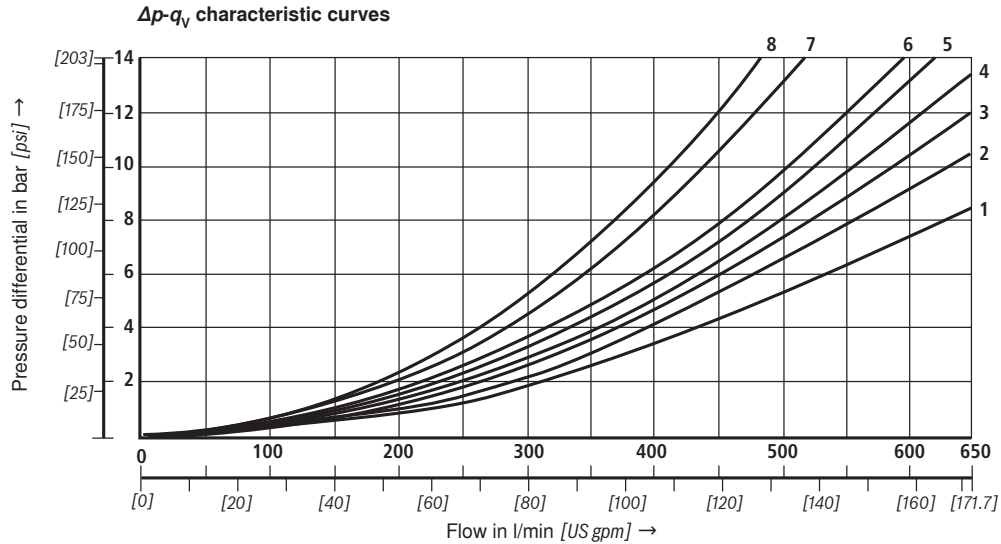

Spool	Spool position			
	P - A	P - B	A - T	B - T
E, C	1	1	1	3
F	1	4	3	3
G	3	1	2	4
H, D	4	4	3	4
J, Q, K	2	2	3	5
L	2	2	3	3
M	4	4	1	4

Spool	Spool position				
	P - A	P - B	A - T	B - T	B - A
P	4	1	1	5	-
R	2	1	1	-	8
U	4	1	1	6	-
V, Z	2	4	3	6	-
W	1	1	1	3	-
T	3	1	2	4	-

7 Spool G central position P - T

8 Spool T central position P - T

Performance limits: NG25 (type W.H 25)
(measured with HLP46, $\vartheta_{oil} = 40 \text{ °C} \pm 5 \text{ °C}$ [$104 \text{ °F} \pm 9 \text{ °F}$])

2-spool-position valves – $q_{V \max}$ in l/min [US gpm]

Spool	Operating pressure p_{\max} in bar [psi]				
	70 [1015]	140 [2030]	210 [3046]	280 [4061]	350 [5076]

X external – spring end position in main valve
(at $p_{St \min} = 13 \text{ bar}$ [188 psi])

C, D, K, Y, Z	700 [185]	700 [185]	700 [185]	700 [185]	650 [172]
---------------	--------------	--------------	--------------	--------------	--------------

X external – spring end position in main valve ¹⁾

C	700 [185]	700 [185]	700 [185]	700 [185]	650 [172]
D, Y	700 [185]	650 [172]	400 [105]	350 [92]	300 [79]
K	700 [185]	650 [172]	420 [111]	370 [98]	320 [84]
Z	700 [185]	700 [185]	650 [172]	480 [127]	400 [105]

X external – hydraulic end position in main valve

HC, HD, HK, HZ, HY	700 [185]	700 [185]	700 [185]	700 [185]	700 [185]
HC./O..., HD./O..., HK./O..., HZ./O...	700 [185]	700 [185]	700 [185]	700 [185]	700 [185]
HC./OF..., HD./OF..., HK./OF..., HZ./OF...	700 [185]	700 [185]	700 [185]	700 [185]	700 [185]
HC./F..., HD./F..., HK./F..., HZ./F...	700 [185]	700 [185]	700 [185]	700 [185]	700 [185]

3-spool-position valves – $q_{V \max}$ in l/min [US gpm]

Spool	Operating pressure p_{\max} in bar [psi]				
	70 [1015]	140 [2030]	210 [3046]	280 [4061]	350 [5076]

X external – spring-centered

E, L, M, Q, U, W	700 [185]	700 [185]	700 [185]	700 [185]	650 [172]
G, T	400 [105]	400 [105]	400 [105]	400 [105]	400 [105]
F	650 [172]	550 [145]	430 [113]	330 [87]	300 [79]
H	700 [185]	650 [172]	550 [145]	400 [105]	360 [95]
J	700 [185]	700 [185]	650 [172]	600 [158]	520 [137]
P	650 [172]	550 [145]	430 [113]	330 [87]	300 [79]
V	650 [172]	550 [145]	400 [105]	350 [92]	310 [82]
R	700 [185]	700 [185]	700 [185]	650 [172]	580 [153]

X external – pressure-centered

(at minimum pilot pressure of 18 bar [261 psi])

E, F, H, J, L, M, P, Q, R, U, V, W	700 [185]	700 [185]	700 [185]	700 [185]	650 [172]
G, T	400 [105]	400 [105]	400 [105]	400 [105]	400 [105]

X external – pressure-centered

(at pilot pressure > 30 bar [435 psi])

G, T	700 [185]	700 [185]	700 [185]	700 [185]	650 [172]
------	--------------	--------------	--------------	--------------	--------------

⚠ Attention!

¹⁾ When the specified flow values are exceeded, the function of the return spring can no longer be guaranteed in the event of a pilot pressure failure!

For further important notes, see page 24!

Characteristic curves: NG32 (measured with HLP46, $\vartheta_{oil} = 40 \text{ }^\circ\text{C} \pm 5 \text{ }^\circ\text{C}$ [104 °F \pm 9 °F])

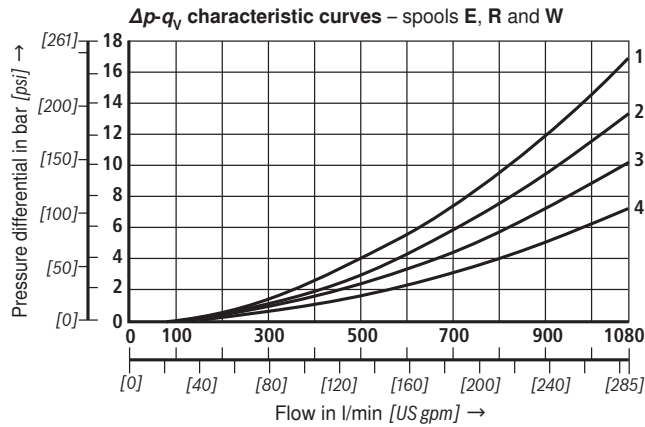

Spool	Spool position				
	P - A	P - B	A - T	B - T	B - A
E	4	4	3	2	-
R	4	4	3	-	1
W	4	4	3	2	-

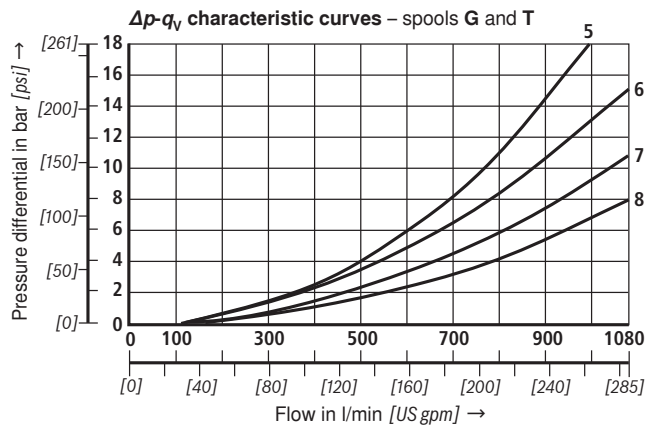

Spool	Spool position				
	P - A	P - B	A - T	B - T	P - T
G	7	8	7	5	6
T	7	8	7	5	6

Performance limits: NG32 (measured with HLP46, $\vartheta_{oil} = 40 \text{ }^\circ\text{C} \pm 5 \text{ }^\circ\text{C}$ [$104 \text{ }^\circ\text{F} \pm 9 \text{ }^\circ\text{F}$])

2-spool-position valves – $q_{V \max}$ in l/min [US gpm]

Spool	Operating pressure p_{\max} in bar [psi]				
	70 [1015]	140 [2030]	210 [3046]	280 [4061]	350 [5076]

X external – spring end position in main valve
(at $p_{St \min} = 10 \text{ bar}$ [145 psi])

C, D, K, Y, Z	1100 [290]	1040 [275]	860 [227]	750 [198]	680 [179]
---------------	---------------	---------------	--------------	--------------	--------------

X external – spring end position in main valve ¹⁾

C	1100 [290]	1040 [275]	860 [227]	800 [211]	700 [185]
---	---------------	---------------	--------------	--------------	--------------

D, Y	1100 [290]	1040 [275]	540 [142]	480 [127]	420 [111]
------	---------------	---------------	--------------	--------------	--------------

K	1100 [290]	1040 [275]	860 [227]	500 [132]	450 [119]
---	---------------	---------------	--------------	--------------	--------------

Z	1100 [290]	1040 [275]	860 [227]	700 [185]	650 [172]
---	---------------	---------------	--------------	--------------	--------------

X external – hydraulic end position in main valve

HC, HD, HK, HZ, HY	1100 [290]	1040 [275]	860 [227]	750 [198]	680 [179]
--------------------	---------------	---------------	--------------	--------------	--------------

3-spool-position valves – $q_{V \max}$ in l/min [US gpm]

Spool	Operating pressure p_{\max} in bar [psi]				
	70 [1015]	140 [2030]	210 [3046]	280 [4061]	350 [5076]

X external – spring-centered

E, J, L, M, Q, R, U, W	1100 [290]	1040 [275]	860 [227]	750 [198]	680 [179]
------------------------	---------------	---------------	--------------	--------------	--------------

G, T, H, F, P	900 [238]	900 [238]	800 [211]	650 [172]	450 [119]
---------------	--------------	--------------	--------------	--------------	--------------

V	1100 [290]	1000 [264]	680 [179]	500 [132]	450 [119]
---	---------------	---------------	--------------	--------------	--------------

X external – pressure-centered

(at minimum pilot pressure of 8.5 bar [123 psi])

alle Spool	1100 [290]	1040 [275]	860 [227]	750 [198]	680 [179]
------------	---------------	---------------	--------------	--------------	--------------

⚠ Attention!

¹⁾ When the specified flow values are exceeded, the function of the return spring can no longer be guaranteed in the event of a pilot pressure failure!

For further important notes, see page 24!

Performance limits: Important notes

General:

⚠ Attention!

The specified switching performance limits are valid for operation with two directions of flows (e.g. from P to A and simultaneous return flow from B to T in the ratio of 1:1).

Due to the flow forces acting within the valves, the permissible switching performance limits may be considerably lower with only one direction of flow (e.g. from P to A while port B is blocked, with flow in only one direction or different flows)!

In the case of such applications, please consult us!

The switching performance limit was established while the solenoids had reached operating temperature, at 10 % undervoltage and without tank pre-loading.

⚠ Attention!

NG16	<ul style="list-style-type: none"> - With X internal pilot oil supply, a pre-load valve must be used at flows < 160 l/min [42 US gpm] due to the negative overlap of spools C, Z and HC, HZ. - When 4/3 directional valves with pressure-centered control spool in the main valve are operated beyond the specified performance limit, a higher pilot pressure is required. At, for example, an operating pressure of $p_{max} = 350 \text{ bar}$ [5076 psi] and a flow of $q_v = 300 \text{ l/min}$ [79 US gpm] a pilot pressure of 16 bar [232 psi] is required. The maximum flow for these valves therefore only depends on the Δp value, which is acceptable for the system. - With X internal pilot oil supply, a pre-load valve must generally be used (see page 35) due to the negative overlap of spools F, G, H, J, P, S, and T.
NG25	<ul style="list-style-type: none"> - With X internal pilot oil supply, a pre-load valve must be used at flows < 180 l/min [47.5 US gpm] due to the negative overlap of spools Z, HZ, and V. - With X internal pilot oil supply, a pre-load valve must generally be used due to the negative overlap of spools C, HC, F, G, H, P, and T.
NG32	<ul style="list-style-type: none"> - With X internal pilot oil supply, a pre-load valve must be used at flows < 180 l/min [47.5 US gpm] due to the negative overlap of spools Z, HZ, and V. - When 4/3 directional valves with pressure-centered control spool in the main valve are operated beyond the specified performance limit, a higher pilot pressure is required. At, for example, an operating pressure of $p_{max} = 350 \text{ bar}$ [5076 psi] and a flow of $q_v = 1100 \text{ l/min}$ [290 US gpm] a pilot pressure of 15 bar [217 psi] is required. The maximum flow for these valves therefore only depends on the Δp value, which is acceptable for the system. - With X internal pilot oil supply, a pre-load valve must generally be used due to the negative overlap of spools C, HC, F, G, H, P and T.

Unit dimensions: NG10 (dimensions in mm [inch])

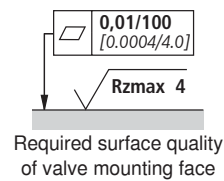
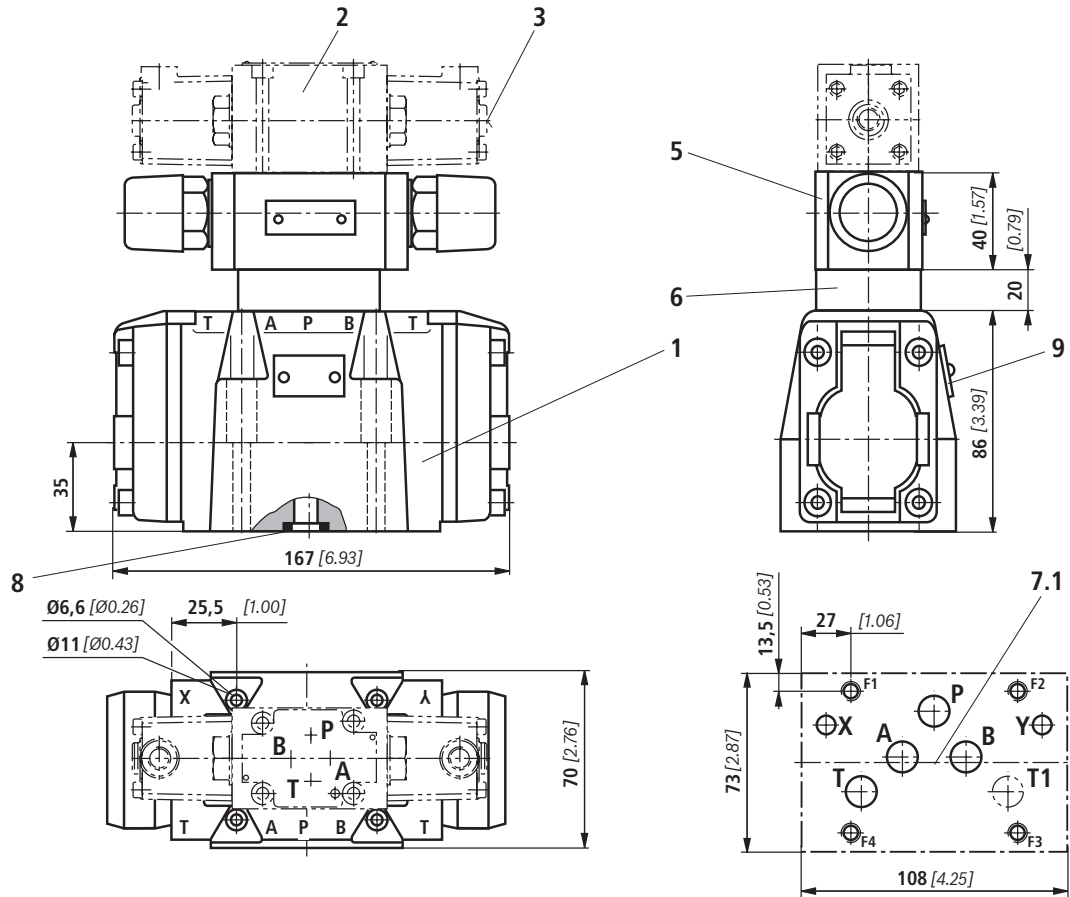

For explanations of items and subplates, see page 30.
For valve mounting screws, see page 31.

Unit dimensions: NG16 (dimensions in mm [inch])

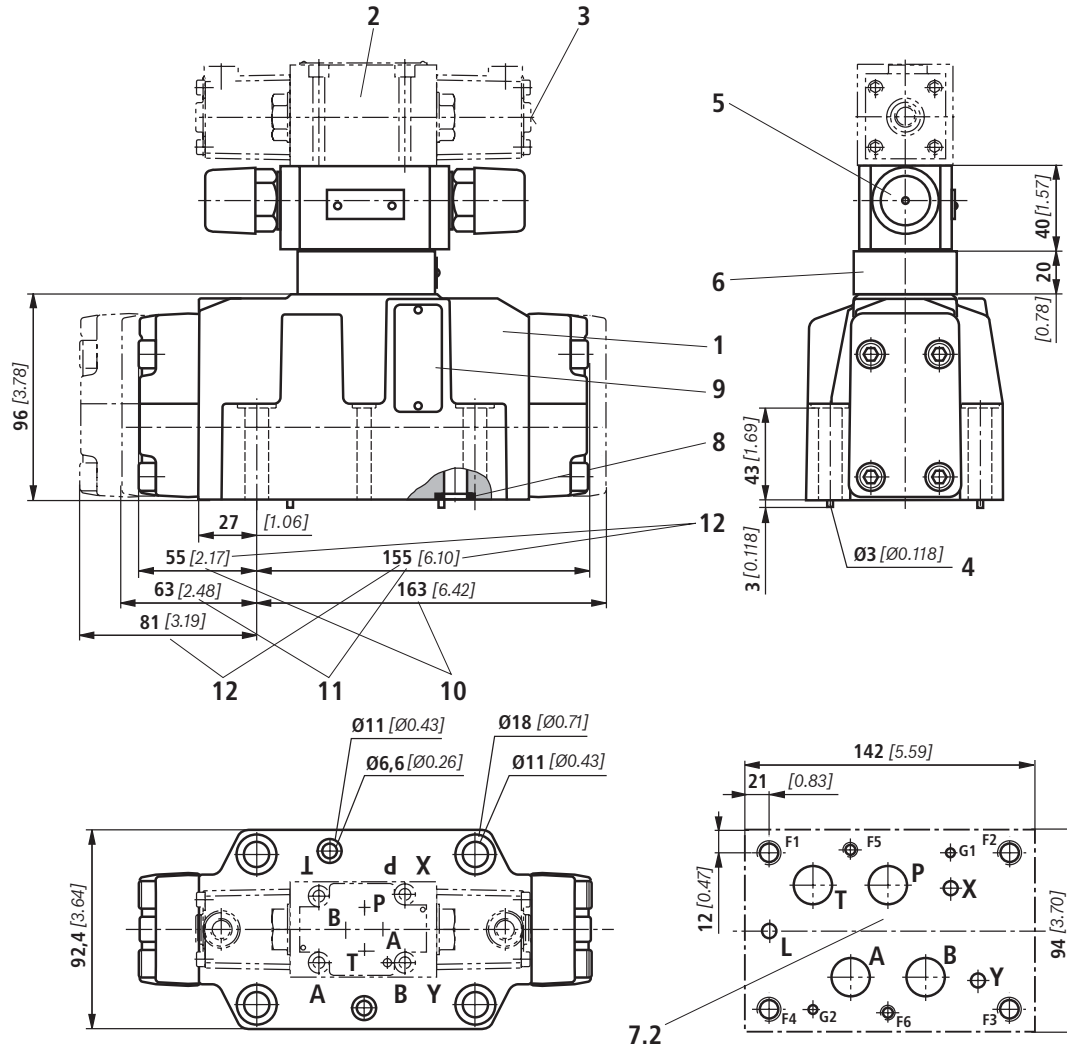

7.2

0,01/100
[0.0004/4.0]

Rzmax 4

Required surface quality
of valve mounting face

For explanations of items and subplates, see page 30.
For valve mounting screws, see page 31.

Unit dimensions: NG25 (type W.H 22) (dimensions in mm [inch])

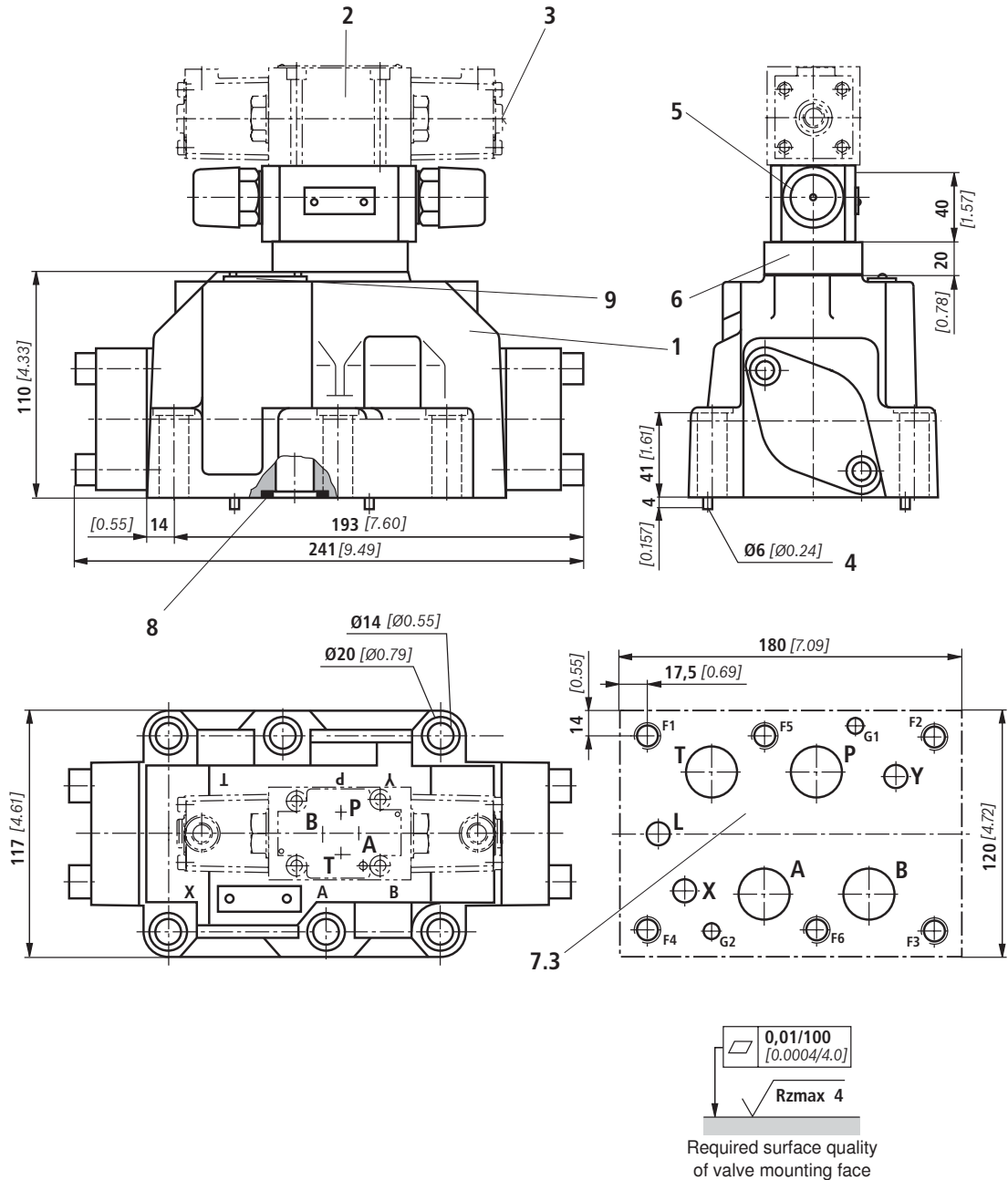

For explanations of items and subplates, see page 30.
For valve mounting screws, see page 31.

Unit dimensions: NG25 (type W.H 25) (dimensions in mm [inch])

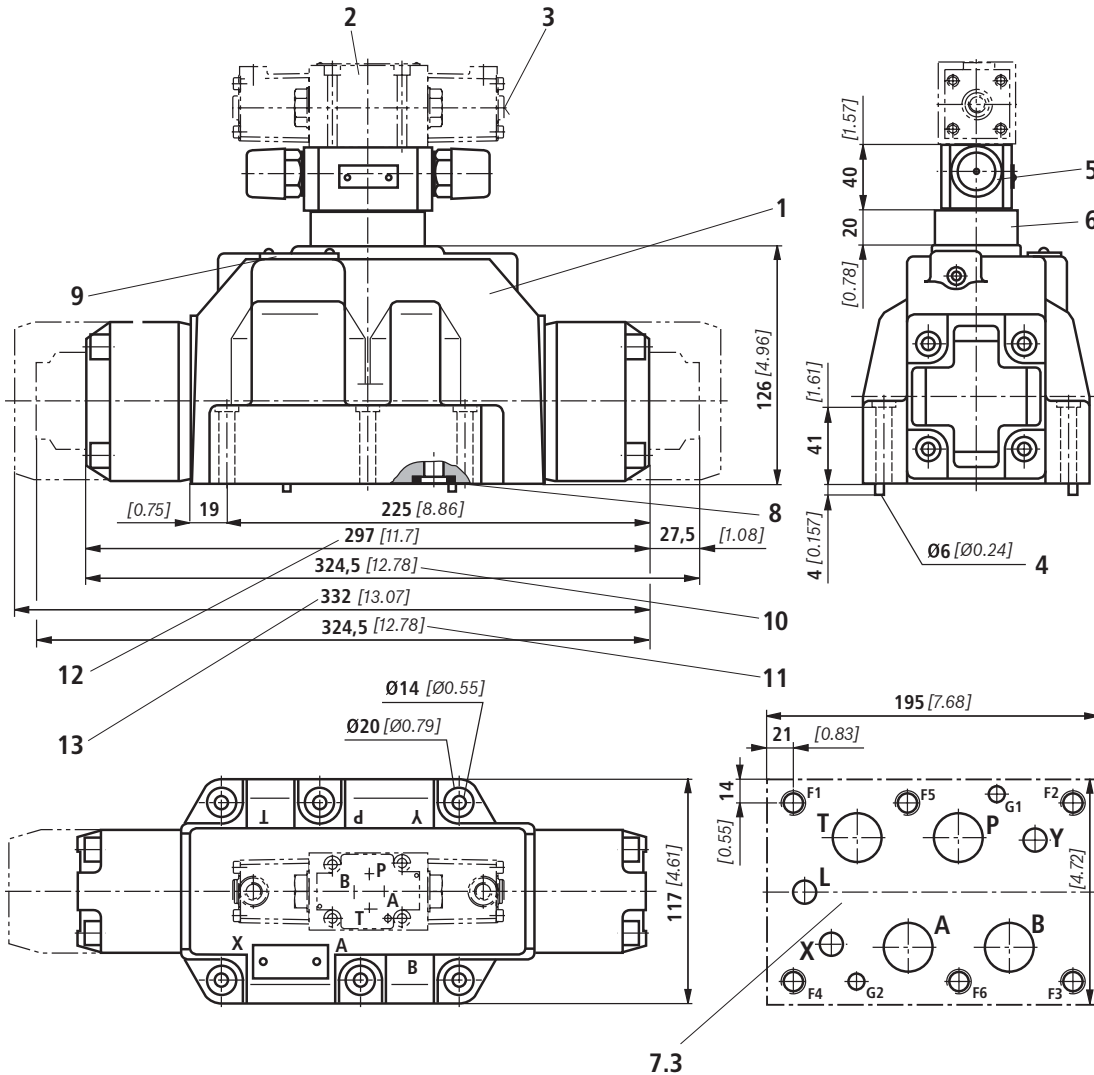

0,01/100
[0.0004/4.0]
Rzmax 4
Required surface quality
of valve mounting face

For explanations of items and subplates, see page 30.
For valve mounting screws, see page 31.

Unit dimensions: NG32 (dimensions in mm [inch])

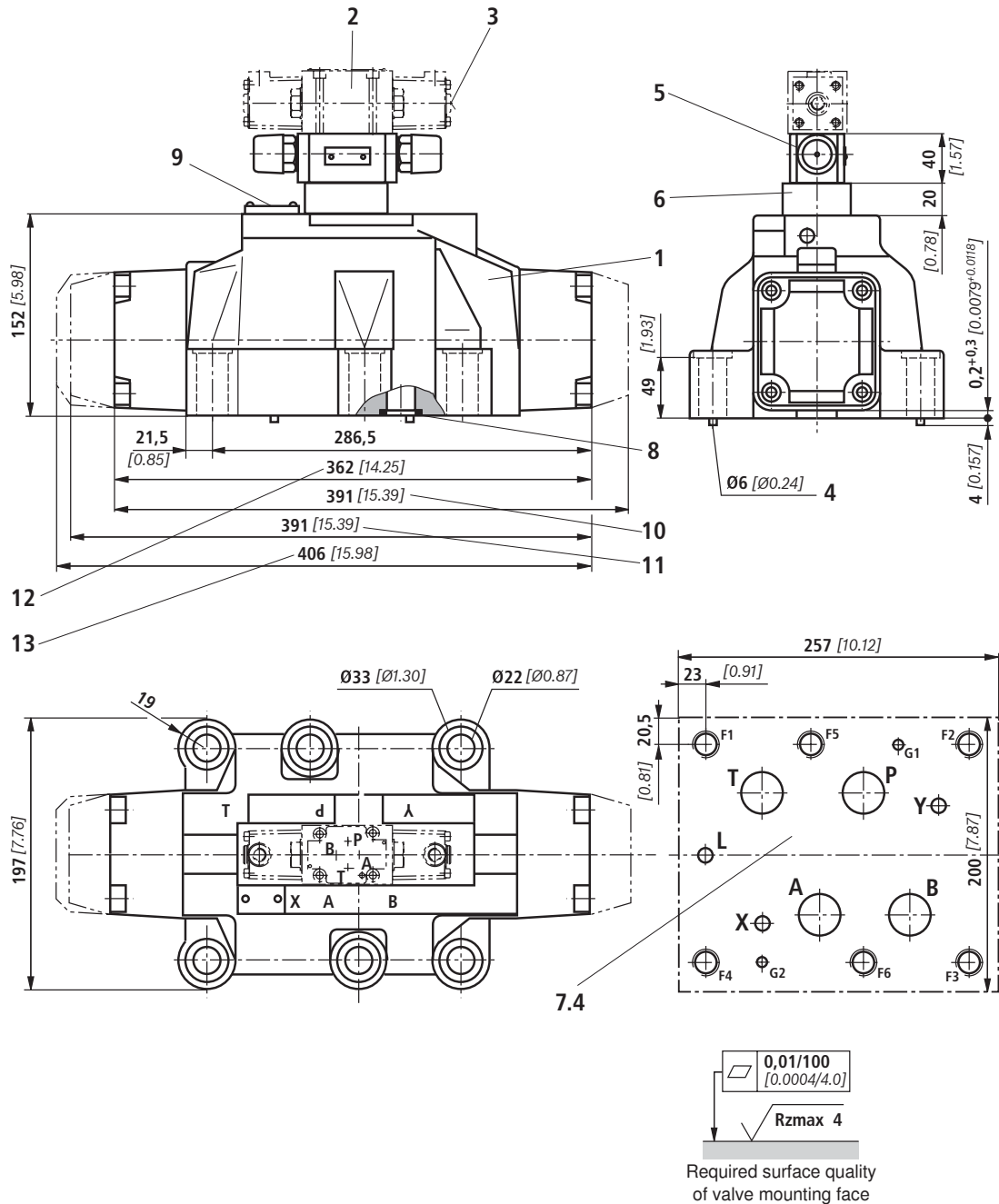

For explanations of items and subplates, see page 30.
For valve mounting screws, see page 31.

Unit dimensions

- 1 Main valve
 - 2 Pilot valve:
For unit dimensions, see basic data sheets
 - Types WPH and WHH: RE 22282
 - Type WM.H: RE 22280
 - 3 Manual override “N”, optional (type WPH only)
 - The manual override can only be operated up to a tank pressure of ca. 50 bar. Avoid damage to the bore for the manual override! (Special tool for actuation, separate order, Material no. **R900024943**).
 - 4 Locating pin
 - 5 Switching time adjustment (6 A/F), optional
 - 6 Pressure reducing valve, optional
 - 7.1 Machined valve mounting face; porting pattern to ISO 4401-05-05-0-05 and NFPA T3.5.1 R2-D05
 - 7.2 Machined valve mounting face; porting pattern to ISO 4401-07-07-0-05 and NFPA T3.5.1 R2-D07
 - 7.3 Machined valve mounting face; porting pattern to ISO 4401-08-08-0-05 and NFPA T3.5.1 R2-D08
 - 7.4 Machined valve mounting face; porting pattern to ISO 4401-10-09-0-05 and NFPA T3.5.1 R2-D10
 - 8 Seal rings
 - 9 Nameplate of complete valve
 - 10 2-spool-position valves with spring end position in main valve (spool symbols A, C, D)
 - 11 2-spool-position valves with spring end position in main valve (spool symbols B, Y)
 - 12 3-spool-position valves, spring-centered;
2-spool-position valves with hydraulic end position in main valve
 - 13 3-spool-position valves, pressure-centered
- Subplates** (separate order)
- NG10 (to data sheet RE 45054)
 - Without ports X, Y: G 534/01 (G3/4)
G 534/12 (SAE-12; 1 1/16-12)¹⁾
 - With ports X, Y: G 535/01 (G3/4)
G 536/01 (G1)
G 535/12 (SAE-12; 1 1/16-12)¹⁾
G 536/12 (SAE-16; 1 5/16-12)¹⁾
 - NG16 (to data sheet RE 45056)
 - G 172/01 (G3/4)
 - G 172/02 (M27 x 2)
 - G 174/01 (G1)
 - G 174/02 (M33 x 2)
 - G 174/08 (flange)
 - G 172/12 (SAE-12; 1 1/16-12)¹⁾
 - G 174/12 (SAE-16; 1 5/16-12)¹⁾
 - NG25 (type W.H 22 to data sheet RE 45058)
 - G 151/01 (G1)
 - G 154/01 (G1 1/4)
 - G 156/01 (G1 1/2)
 - G 155/12 (SAE-16; 1 5/16-12)¹⁾
 - G 154/12 (SAE-20; 1 5/8-20)¹⁾
 - G 156/12 (SAE-24; 1 7/8-20)¹⁾
 - NG25 (type W.H 25 to data sheet RE 45058)
 - G 151/01 (G1)
 - G 153/01 (G1), for valves with pressure-centered zero position
 - G 154/01 (G1 1/4)
 - G 154/08 (flange)
 - G 156/01 (G1 1/2)
 - G 153/12 (SAE-16; 1 5/16-12)¹⁾
 - G 154/12 (SAE-20; 1 5/8-20)¹⁾
 - G 156/12 (SAE-24; 1 7/8-20)¹⁾
 - NG32 (to data sheet RE 45060)
 - G 157/01 (G1 1/2)
 - G 157/02 (M48 x 2)
 - G 158/10 (flange)
 - G 157/12 (SAE-24; 1 7/8-12)¹⁾

¹⁾ on request

For valve mounting screws, see page 31.

Unit dimensions

Valve mounting screws (separate order)

– NG10:

4 hexagon socket head cap screws, metric
ISO 4762 - M6 x 45 - 10.9-flZn-240h-L
(Friction coefficient $\mu_{\text{total}} = 0.09$ to 0.14);
tightening torque $M_T = 12.5$ Nm [9.2 ft-lbs] $\pm 10\%$,
Material no. **R913000258**

4 hexagon socket head cap screws, UNC
1/4-20 UNC x 1 3/4" ASTM-A574
on request

– NG16:

4 hexagon socket head cap screws, metric
ISO 4762 - M10 x 60 - 10.9-flZn-240h-L
(Friction coefficient $\mu_{\text{total}} = 0.09$ to 0.14);
tightening torque $M_T = 75$ Nm [55.3 ft-lbs] $\pm 10\%$,
Material no. **R913000116**

2 hexagon socket head cap screws, metric
ISO 4762 - M6 x 60 - 10.9-flZn-240h-L
(Friction coefficient $\mu_{\text{total}} = 0.09$ to 0.14);
tightening torque $M_T = 12.5$ Nm [9.2 ft-lbs] $\pm 10\%$,
Material no. **R913000115**

4 hexagon socket head cap screws, UNC
3/8-16 UNC x 2 1/4" ASTM-A574
on request

2 hexagon socket head cap screws, UNC
1/4-20 UNC x 2 1/4" ASTM-A574
on request

– NG25:

6 hexagon socket head cap screws, metric
ISO 4762 - M12 x 60 - 10.9-flZn-240h-L
(Friction coefficient $\mu_{\text{total}} = 0.09$ to 0.14);
tightening torque $M_T = 130$ Nm [95.9 ft-lbs] $\pm 10\%$,
Material no. **R913000121**

6 hexagon socket head cap screws, UNC
1/2-13 UNC x 2 1/2" ASTM-A574
on request

– NG32:

6 hexagon socket head cap screws, metric
ISO 4762 - M20 x 80 - 10.9-flZn-240h-L
(Friction coefficient $\mu_{\text{total}} = 0.09$ to 0.14);
tightening torque $M_T = 430$ Nm [317.2 ft-lbs] $\pm 10\%$,
Material no. **R901035246**

6 hexagon socket head cap screws, UNC
3/4-10 UNC x 3 1/4" ASTM-A574
on request

Stroke adjustment, mounting options (dimensions in mm [inch])

The stroke adjustment feature limits the stroke of control spool (1). To shorten the spool stroke, loosen locknut (2) and turn adjustment spindle (3) clockwise. During this, pressure chamber (4) must be pressureless.

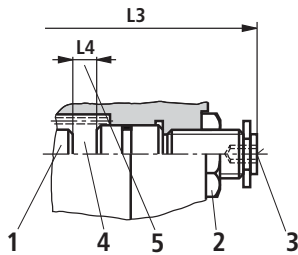

NG	L4
10	6.5 [0.26]
16	10 [0.39]
25 (type 4W.H 22)	9.5 [0.37]
25 (type 4W.H 25)	12.5 [0.49]
32	15 [0.59]

For further dimensions see below and page 33.

5 Adjustment range

- NG10:
1 turn = 1 mm [0.0394 inch] adjustment travel
- NG16 to 32:
1 turn = 1.5 mm [0.0591 inch] adjustment travel

Stroke limitation on side A

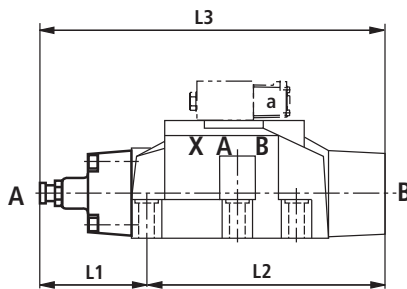

Stroke limitation on side B

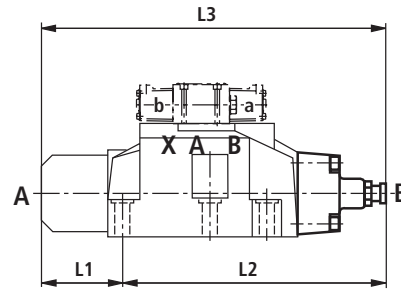

Mounting options	Ordering code	NG	3-spool-position valve ¹⁾					
			Spring-centered			Pressure-centered		
			L1	L2	L3	L1	L2	L3
Stroke adjustment on valve sides A and B	10	10	90 [3.54]	144 [5.67]	234 [9.21]			
		16	100 [3.94]	200 [7.87]	300 [11.81]			
		25 ¹⁾	96 [3.77]	241 [9.49]	337 [13.27]			
		25 ²⁾	123 [4.84]	276 [10.87]	399 [15.71]			
		32	133 [5.24]	344 [13.54]	477 [18.78]			
Stroke adjustment on valve side A	11	10	90 [3.54]	106 [4.17]	196 [7.72]			
		16	100 [3.94]	156 [6.14]	256 [10.08]			
		25 ¹⁾	96 [3.77]	193 [7.60]	289 [11.38]			
		25 ²⁾	123 [4.84]	225 [8.86]	348 [13.70]			
		32	133 [5.24]	287 [11.30]	420 [16.54]			
Stroke adjustment on valve side B	12	10	52 [2.05]	144 [5.67]	196 [7.72]	-	-	-
		16	56 [2.20]	200 [7.87]	256 [10.08]	81 [3.19]	200 [7.87]	281 [11.06]
		25 ¹⁾	48 [1.89]	241 [9.49]	289 [11.38]	-	-	-
		25 ²⁾	72 [2.83]	276 [10.87]	348 [13.70]	107 [4.21]	276 [10.87]	283 [11.14]
		32	76 [2.99]	344 [13.54]	420 [16.54]	120 [4.72]	344 [13.54]	464 [18.27]

¹⁾ With spool symbol A, only version "11" possible, with spool symbol B, only version "12".

Stroke adjustment, mounting options (dimensions in mm [inch])

Mounting options	Ordering code	NG	2-spool-position valve									
			Spring end position						Hydraulic end position			
			C, D, K, Z			B, Y			HC, HD, HY, HK, HZ			
			L1	L2	L3	L1	L2	L3	L1	L2	L3	
Stroke adjustment on valve sides A and B	10	10	-	-	-	-	-	-	-	90 [3.54]	144 [5.67]	234 [9.21]
		16	-	-	-	-	-	-	-	100 [3.94]	200 [7.87]	300 [11.81]
		25 ¹⁾	96 [3.78]	241 [9.49]	337 [13.27]	96 [3.78]	241 [9.49]	337 [13.27]	96 [3.78]	241 [9.49]	337 [13.27]	
		25 ²⁾	-	-	-	-	-	-	-	123 [4.84]	276 [10.87]	399 [15.71]
		32	-	-	-	-	-	-	-	133 [5.24]	344 [13.54]	477 [18.78]
Stroke adjustment on valve side A	11	10	90 [3.54]	106 [4.17]	196 [7.72]	-	-	-	90 [3.54]	106 [4.17]	196 [7.72]	
		16	100 [3.94]	180 [7.09]	280 [11.02]	-	-	-	100 [3.94]	156 [6.14]	256 [10.08]	
		25 ¹⁾	96 [3.78]	193 [7.60]	289 [11.38]	96 [3.78]	193 [7.60]	289 [11.38]	96 [3.78]	193 [7.60]	289 [11.38]	
		25 ²⁾	123 [4.84]	253 [9.96]	376 [14.8]	-	-	-	123 [4.84]	225 [8.86]	348 [13.70]	
		32	133 [5.24]	316 [12.44]	449 [17.68]	-	-	-	133 [5.24]	287 [11.30]	420 [16.53]	
Stroke adjustment on valve side B	12	10	-	-	-	52 [2.05]	144 [5.67]	196 [7.72]	52 [2.05]	144 [5.67]	196 [7.72]	
		16	-	-	-	80 [3.15]	200 [7.87]	280 [11.02]	56 [2.21]	200 [7.87]	256 [10.08]	
		25 ¹⁾	48 [1.89]	241 [9.49]	289 [11.38]	48 [1.89]	241 [9.49]	289 [11.38]	48 [1.89]	241 [9.49]	289 [11.38]	
		25 ²⁾	-	-	-	100 [3.94]	276 [10.87]	376 [14.80]	72 [2.84]	276 [10.87]	348 [13.70]	
		32	-	-	-	105 [4.13]	344 [13.54]	449 [17.68]	76 [2.99]	344 [13.54]	420 [16.53]	

¹⁾ Type 4W.H 22

²⁾ Type 4W.H 25

Switching time adjustment

The switching time of main valve (1) can be influenced by using a double throttle check valve (2) (type Z2FS 6 to data sheet RE 27506).

Conversion of meter-in (3) into meter-out control (4):

Remove pilot valve (5) – plate (6) for accommodating the seal rings remains in place – turn switching time adjustment feature (2) around its longitudinal axis and put it down again, re-mount pilot valve (5).

Tightening torque of screws (7) $M_T = 9 \text{ Nm}$ [6.6 ft-lbs].

⚠ Attention!

The conversion may only be carried out by authorized specialists or in the factory!

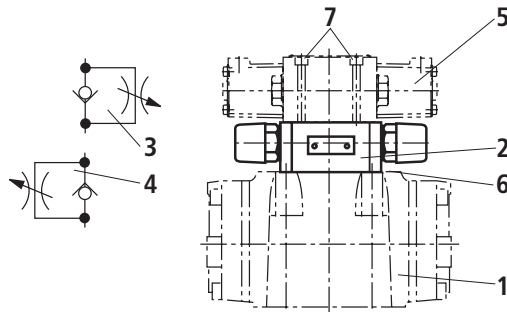

Type 4W.H 10 ..4X/...S

Type 4W.H 10 ..4X/...S2

Pressure reducing valve "D3"

Pressure reducing valve (8) must be used in the case of pilot pressures above 250 bar [3626 psi] (with type 4W.H 22: 210 bar [3046 psi]) and version "H-".

The secondary pressure is held constant at 45 bar [652 psi].

⚠ Attention!

When a pressure reducing valve "D3" (8) is used, a throttle insert "B10" must be provided in the P channel of the pilot valve.

Tightening torque of screws (7) $M_T = 9 \text{ Nm}$ [6.6 ft-lbs].

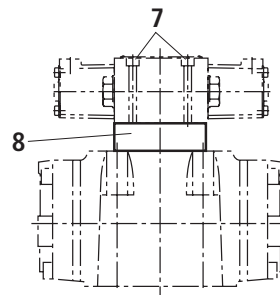

Type 4W.H 10 ..4X/.../...D3

Pre-load valve (not for NG10)

For valves with pressureless circulation and internal pilot oil supply, a pre-load valve (9) must be installed in channel P of the main valve to build up the minimum pilot pressure.

The pressure differential of the pre-load valve must be added

to the pressure differential of the main valve (see characteristic curves) to obtain a total value.

The cracking pressure is ca. 4.5 bar [65 psi].

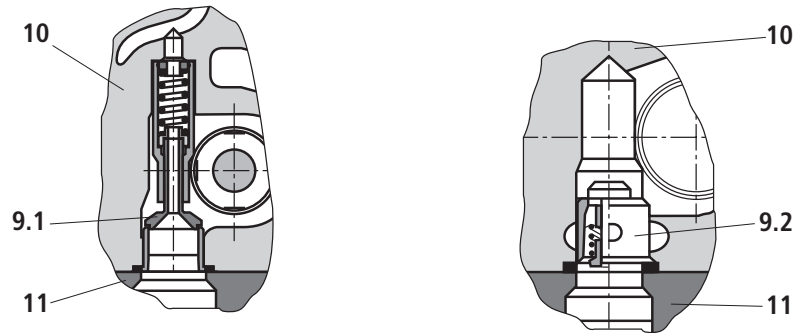

- 9.1 Pre-load valve NG16
- 9.2 Pre-load valve NG25 and NG32
- 10 Main valve
- 11 Subplate

Type	Material number P4,5
4W.H 16 ...	R901002365
4W.H 22 ...	R900315596
4W.H 25 ...	R900303717
4W.H 32 ...	R900317066

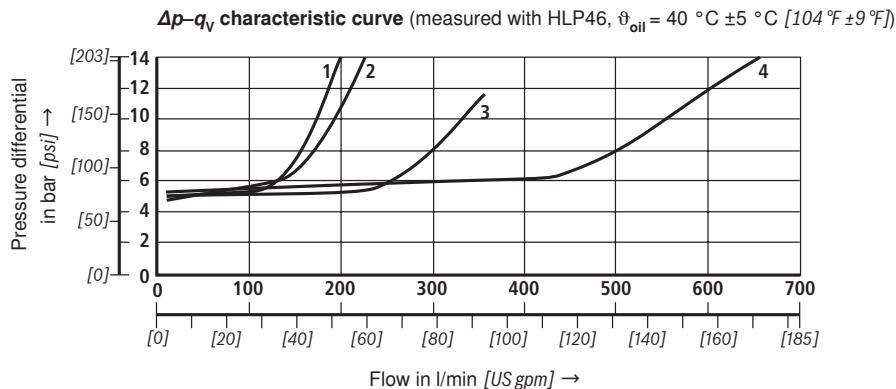

- 1 NG16
- 2 NG25 (type 4W.H 25 ...)
- 3 NG25 (type 4W.H 22 ...)
- 4 NG32

Notes

© This document, as well as the data, specifications and other information set forth in it, are the exclusive property of Bosch Rexroth AG. It may not be reproduced or given to third parties without its consent. The data specified above only serve to describe the product. No statements concerning a certain condition or suitability for a certain application can be derived from our information. The information given does not release the user from the obligation of own judgment and verification. It must be remembered that our products are subject to a natural process of wear and aging.