

◀ CAPSTAN PUMP ▶

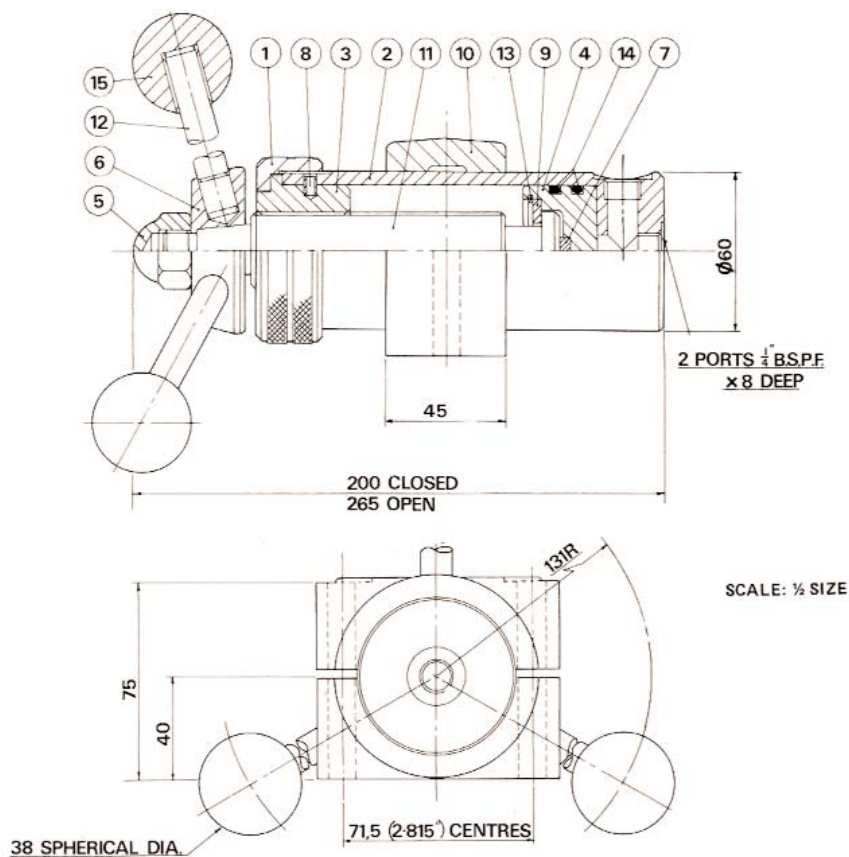

Item no.	Description	Part no.
1	Gland nut	SP 50-50-0010
2	Cylinder	SP 50-50-0065 ECAS1
3	Gland bush	SP 50-50-0030
4	Piston	SP 50-50-0040
5	Cap nut	SP 50-50-0140
6	Capstan boss	SP 50-50-0251
7	Nylon slug	SP 50-50-0290
8	Locking pin	SP 50-50-0410
9	Retaining washer	SP 50-50-0470
10	Mounting bracket	SP 50-50-0501
11	Capstan pump screw	SP 50-50-0560
12	Capstan spoke	SP 50-50-0570
13	Internal circlip	SP 50-50-13
14	'O' ring	SP 50-50-14
15	Handle knob	SP 50-50-15

MOUNTING ▶

All Capstan pumps are supplied with mounting clamp 50-501 as standard equipment.

◀ CAPSTAN PUMP ▶



Code: 50-50-2



Code: 50-501

General specification	Imperial	Metric
Normal operating pressure	2500 lbf/in ²	176 kgf/cm ²
Maximum pressure	3000 lbf/in ²	211 kgf/cm ²
Output for 65mm (2.56") travel	7.79 in ³	127.6 cm ³
Output for one complete rotation of handle	.180 in ³	2.95 cm ³
Weight	8.25 lbs	3.74 kg

MOUNTING ▶

All Capstan pumps are supplied with mounting clamp 50-501 as standard equipment.