

HC2 miniBOOSTER



HC2 versions: 11 different intensification factors

P_{IN}: 20–207 bar (inlet pressure)

P_H: 800 bar maximum (outlet pressure)

P_{RETURN}: As low as possible (return pressure to tank)

P_{OUTLET}: $P_H = (P_{IN} - P_{RETURN}) i$ (intensification)

Mounting: Inline tube

Accessories: Pilot-operated dump valve available

A model = no dump valve

B model = with dump valve

G model = direct proportionally controlled

Description

The HC2 is a compact unit weighing only 1.0 kg. It is ideal for use in a variety of applications where building and maintaining high pressure is required.

The HC2 raises supplied pressure to a higher outlet pressure and automatically compensates for consumption of oil to maintain the high pressure. Adjustment of the outlet pressure is carried out by varying the supplied pressure.

Flow rates

Intensification factor <i>i</i>	Max. outlet flow l/ min	Max. inlet flow l/ min
1.2	1.2	8.0
1.5	1.0	8.0
2.0	2.0	12.0
2.8	2.2	13.0
3.2	2.5	15.0
4.0	2.0	14.0
5.0	1.6	14.0
6.6	1.3	13.0
9.0	0.9	13.0
13.0	0.6	12.0
20.0	0.3	12.0

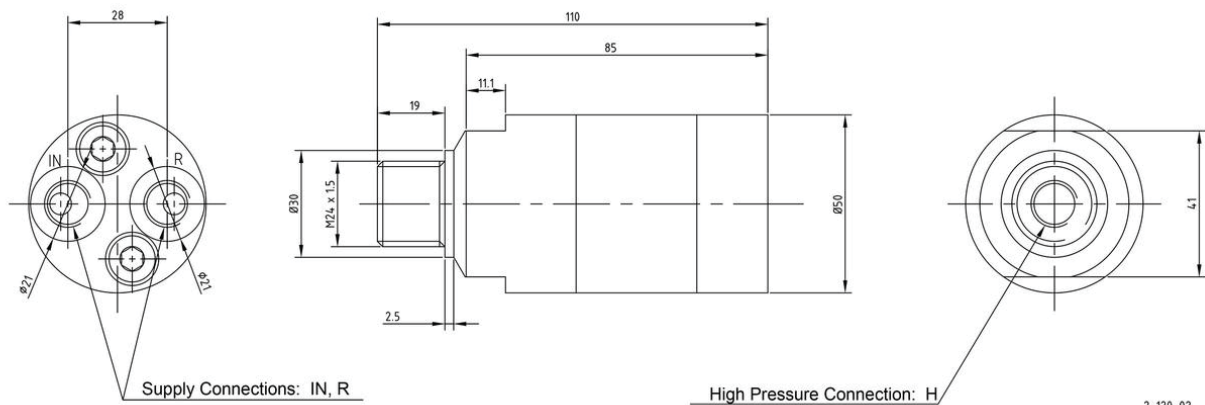

Functions

The basic operation is illustrated in the function diagram. Oil is fed through the directional valve CV to the IN port, flowing freely through the check valves KV1, KV2 and DV to the high- pressure side H. In this condition maximum flow through the booster is achieved giving a fast-forward function.

When pump pressure is reached on the high- pressure side H, valves KV1, KV2 and DV will close. The end pressure will be achieved by the oscillating pump unit OP. The unit will automatically stall when end pressure on the high- pressure side H is reached. If a pressure drop on the high- pressure side exists due to consumption or leakage, the OP valve will automatically operate to maintain the end pressure.

Function diagram

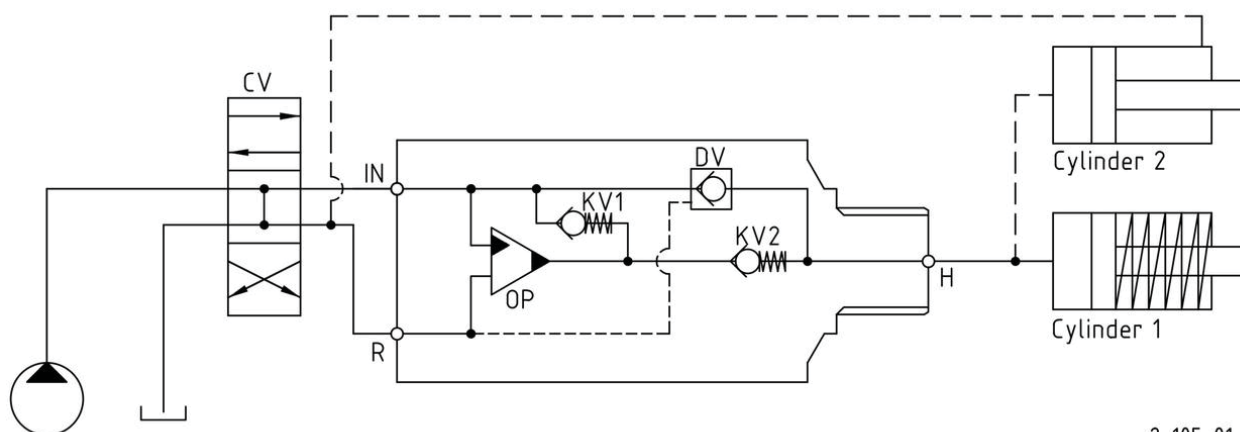

Connection types

Connection	IN / R	H
1	1/4" BSP	1/4" BSP
2	7/16-20 UNF	9/16-18 UNF

Max. tightening torque BSP

	IN / R	H
	1/4" BSP	1/4" BSP
with steel washer	4.0 da/ Nm	4.0 da/ Nm
with aluminium washer	3.0 da/ Nm	-
with cutting edge	4.0 da/ Nm	4.0 da/ Nm

Max. tightening torque UNF

	IN / R	H
	7/16-20" UNF	9/16-18" UNF
with o- ring	2.0 da/ Nm	3.5 da/ Nm

Fluids and materials

Please see: General specifications

Ordering an HC2

Ordering example of an HC2 with i = 4.0 DV incorporated and BSP connections: HC2 - 4.0 - B - 1

Model	Intensification, i	Dump valve	Connections
HC2	your selection...	your selection...	your selection...
	see flow rate table	A = (no) / A model	1
		B = (yes) / B model	2
		G = (proportional) / G model	

