

Electric Drives
and Controls

Hydraulics

Linear Motion and
Assembly Technologies

Pneumatics

Service

Rexroth
Bosch Group

1/24

4/2 and 4/3 directional valves, internally pilot operated, externally pilot operated

RE 24751-XD-B2/08.12
Replaces: 01.10

Type H-4WEH...XD...

Sizes 10, 16, 25, 32
Component series 4X, 6X, 7X
Maximum operating pressure 350 bar
Maximum flow 1100 l/min

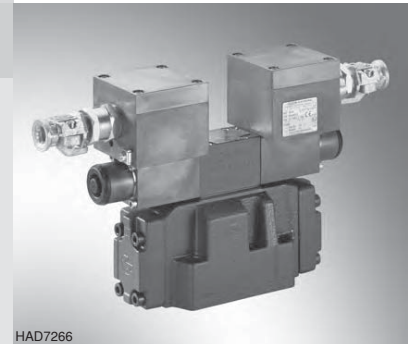

HAD7266

ATEX units
For explosive areas

Part II Data sheet



Information on the explosion protection:

- Area of application in accordance with the Explosion Protection Directive 94/9/EC: **I M2, II 2G**
- Type of protection of the valve solenoids:
Ex d I Mb, Ex d IIC T4 Gb
EN 60079-0:2009 / EN 60079-1:2007

Special features of seawater-resistant valves

- The external metal parts are galvanized or treated with an anti-corrosion agent.
- The conditional seawater resistance is defined by the "SO329" ordering code.

What you need to know about these operating instructions

These operating instructions apply to the explosion-proof version of Rexroth valves and consist of the following three parts:

- Part I General information 07010-X-B1
- Part II Data sheet 24751-XD-B2
- Part III Product-specific instructions 24751-XD-B3

Operating instructions 24751-XD-B0

You can find further information on the correct handling of Rexroth hydraulic products in our publication "General product information on hydraulic products" 07008.

Table of contents

Contents	Page
Features	2
Function, section	3
Ordering code and scope of delivery	4
Control spool symbols	6
Pilot oil supply	9
Technical data	10
Electrical connection	13
Characteristic curves, performance limits	15
Switching time adjustment, pressure reducing valve, preload valve	19
Device dimensions	20

Features

- Valve to control the start, stop and direction of a flow, for intended use in explosive areas
- Electro-hydraulic actuation (WEH)
- For subplate mounting, porting pattern according to DIN 24340-A and ISO 4401, subplates available in FE/ZN version (see pages 20 to 23)
- Spring centering, spring end position or hydraulic end position
- Wet-pin DC solenoids
- Manual override
- Electrical connection as individual connection with cable gland (see page 13)
- Switching time adjustment, optional
- Preload valve in channel P of the main valve, optional

Function, section

Type H-4WEH 16...XD...

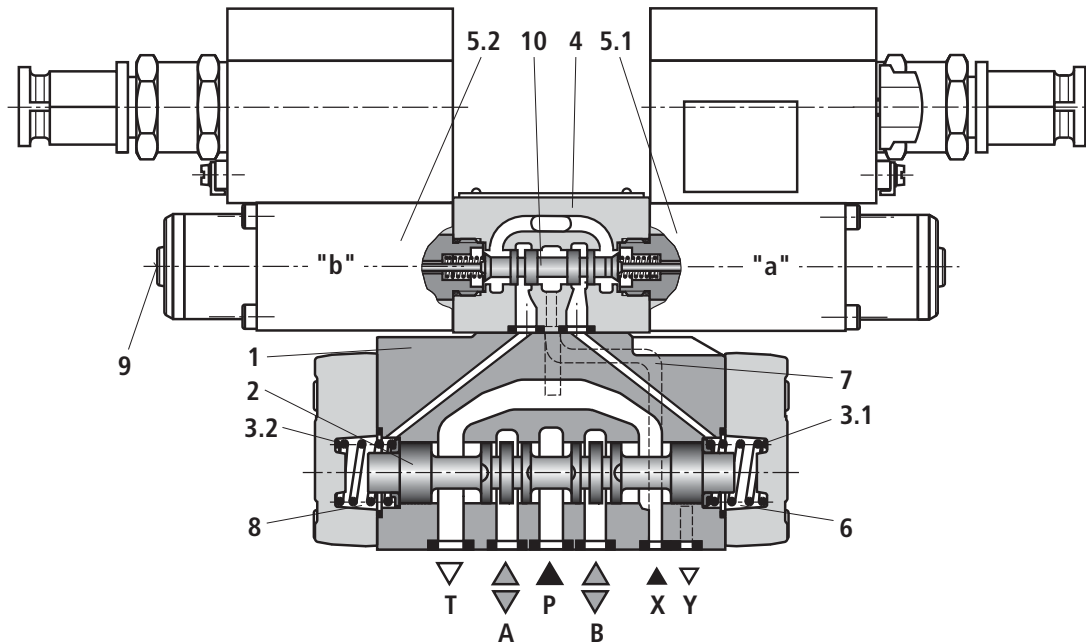

Directional valve type H-4WEH...

The valve type H-4WEH is a directional spool valve with electro-hydraulic actuation. It controls the start, stop and direction of a flow.

The directional valves basically consist of the main valve with housing (1), the main control spool (2), one or two return springs (3.1) and (3.2), as well as the pilot control valve (4) with one or two solenoids "a" (5.1) and/or "b" (5.2).

The main control spool (2) in the main valve is held in the zero or initial position by the springs or by means of pressurization. In the initial position, the two spring chambers (6) and (8) are connected with the tank in a depressurized form via the pilot control valve (4). The pilot control valve is supplied with pilot oil via the control line (7). Supply can be effected internally or externally (externally via port X).

Upon actuation of the pilot control valve, e.g. solenoid "a", the pilot control spool (10) is moved to the left and thus, the spring chamber (8) is pressurized with pilot pressure. The spring chamber (6) remains depressurized.

The pilot pressure acts on the left side of the main control spool (2) and moves it against the spring (3.1). This connects ports P with B and A with T in the main valve.

When the solenoid is switched off, the pilot control spool returns into the initial position (except for impulse spool). The spring chamber (8) is unloaded to the tank.

The pilot oil from the spring chamber is displaced into channel Y via the pilot control valve.

The pilot oil supply and return can be effected internally or externally.

The manual override (9) allows control spool (10) to be moved without solenoid energization.

Control spool symbols

2 spool positions

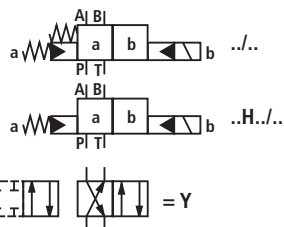
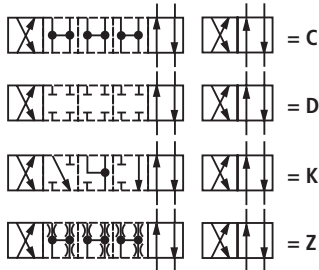
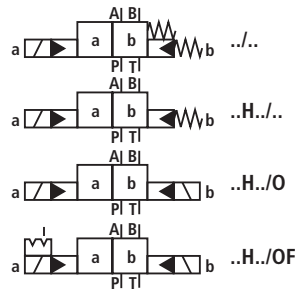

3 spool positions

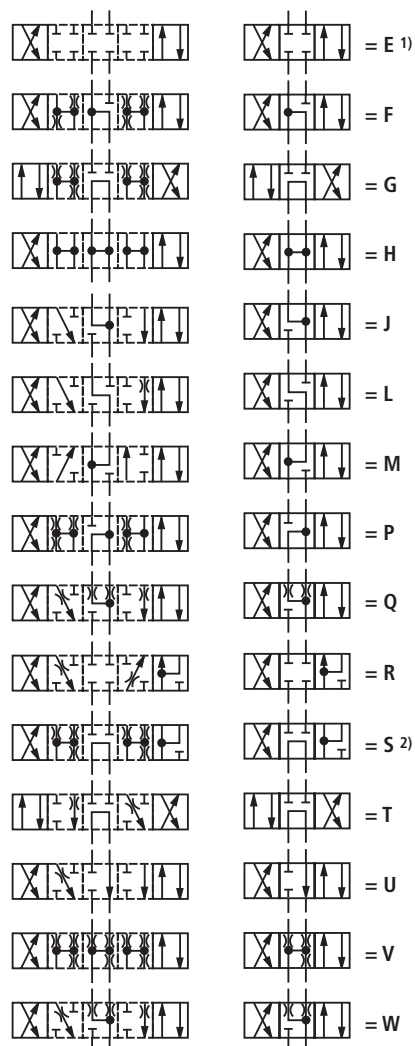
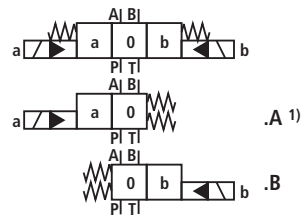

1) Example: Control spool E with spool position "a"
Order example:
H-4WEH 16 EA7X/6EG24N9XDETSZ2B10..V..

2) Control spool S only for size 16

Other control spool variants upon request

Control spool symbols for valves with 2 spool positions

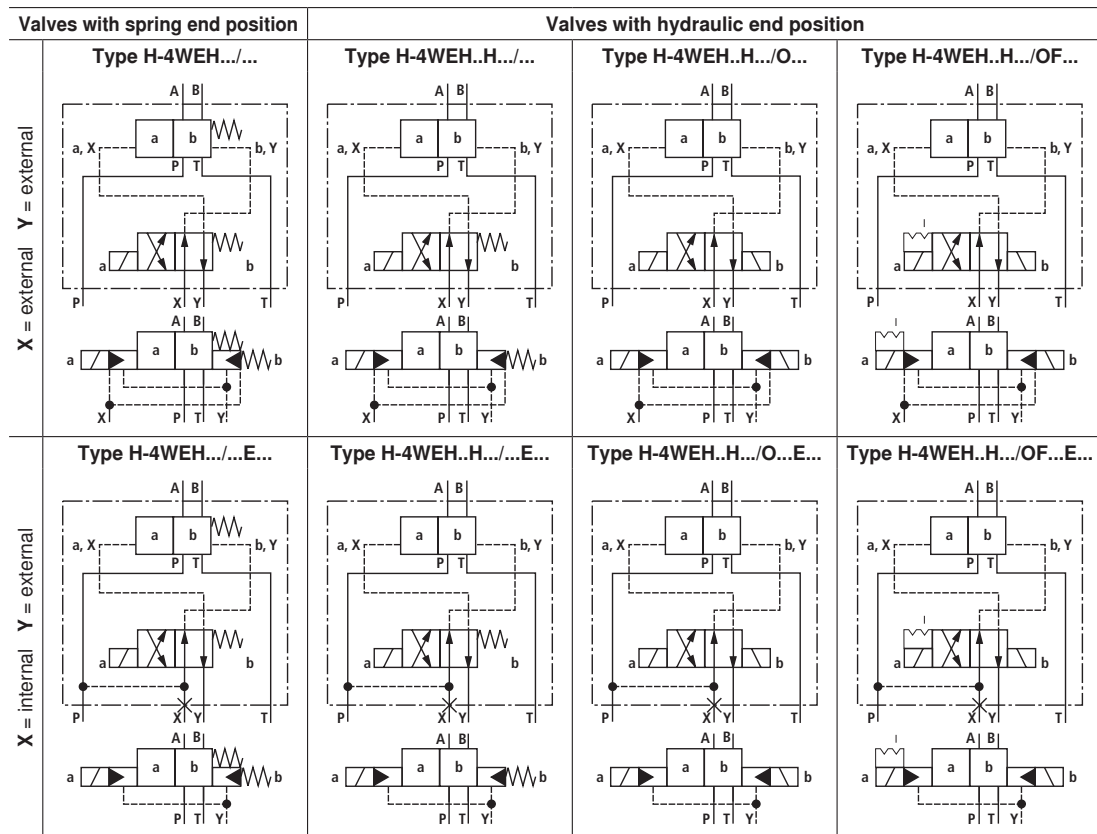

Continuation, see next page

Control spool symbols for valves with 2 spool positions

Continuation from previous page

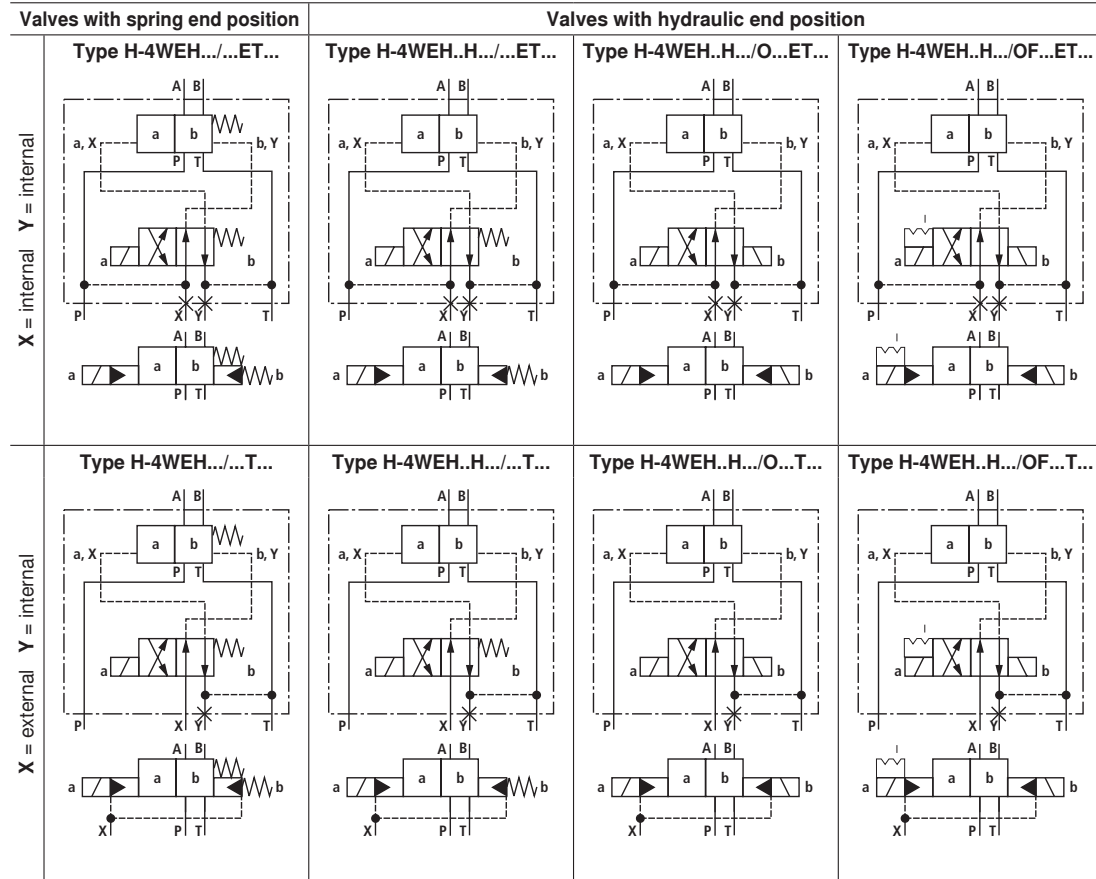

Control spool symbols for valves with 3 spool positions

Valves with spring-centered zero position

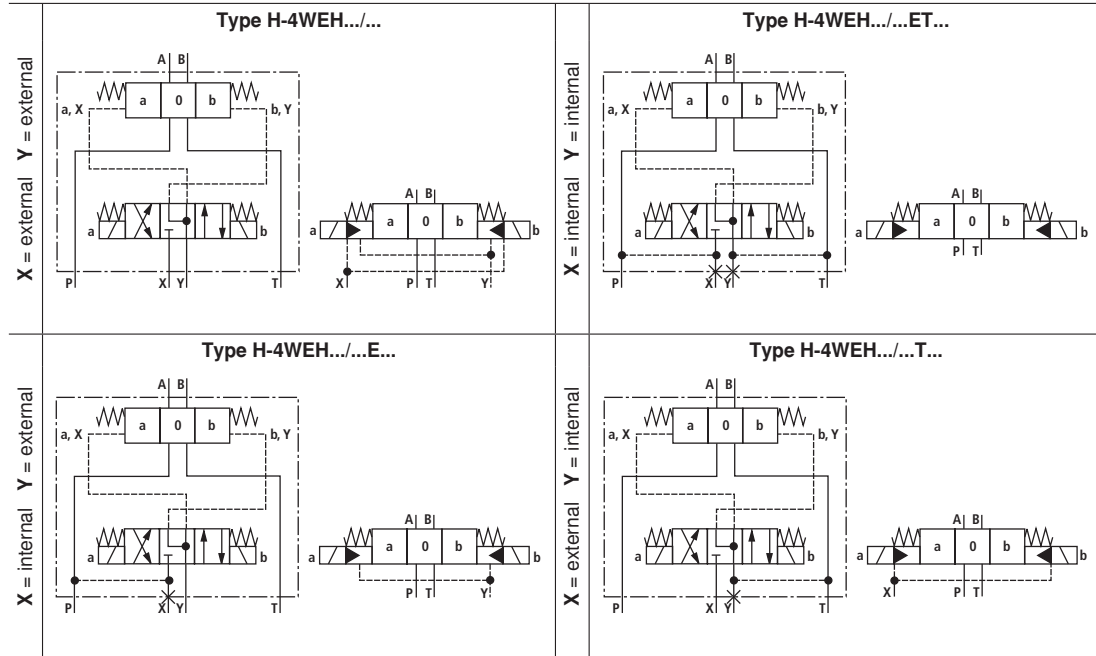

Pilot oil supply

Type H-4WEH...

The pilot oil supply is effected **externally** via the X channel from a separate circuit.

The pilot oil return is effected **externally** via the Y channel into the tank.

Type H-4WEH...E...

The pilot oil supply is effected **internally** from the P channel of the main valve.

The pilot oil return is effected **externally** via the Y channel into the tank. In the subplate, port X is closed.

Type H-4WEH...ET...

The pilot oil supply is effected **internally** from the P channel of the main valve.

The pilot oil return is effected **internally** via the T channel into the tank. In the subplate, ports X and Y are closed.

Type H-4WEH...T...

The pilot oil supply is effected **externally** via the X channel from a separate circuit.

The pilot oil return is effected **internally** via the T channel into the tank. In the subplate, port Y is closed.

Throttle insert

Use of the throttle insert (2) is necessary if the pilot oil supply in the P channel of the pilot control valve (1) is to be limited.

The throttle insert (2) is inserted in channel P of the pilot control valve (1).

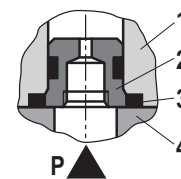

- 1 Pilot control valve
- 2 Throttle insert
- 3 Seal ring
- 4 Main valve

Technical data

general

Installation position	Any; horizontal with valves with hydraulic control spool return "H" and control spool C, D, K, Z or Y					
Ambient temperature range	°C	-20 ... +80				
Storage temperature range	°C	+15 ... +30				
Sizes	Size	10	16	25	32	
Weight	Valve with one solenoid	kg	11	13.5	22	39
	Valve with two solenoids, spring-centered	kg	14	16.5	25	42
	Switching time adjustment	kg	0.8			
	Pressure reducing valve	kg	0.4			
Surface protection	Valve body	Pilot control valve	Galvanically coated			
		Main valve	Standard: Painting, layer thickness max. 100 µm SO329: Galvanically coated, Zn and passivated			
	Solenoid		Galvanically coated			

hydraulic

Sizes	Size	10	16	25	32	
Maximum operating pressure						
Ports P, A, B	bar	350				
Port T	with pilot oil return Y external	bar				250
	with pilot oil return Y internal	bar				210
Port Y	with pilot oil return external	bar				210
Flow of the main valve	l/min	up to 160	up to 300	up to 650	up to 1100	
Maximum pilot pressure	bar	250 (with a higher pilot pressure, use of a pressure reducing valve is required)				
Minimum pilot pressure						
– with pilot oil supply X external or internal (control spool D, K, E, J, L, M, Q, R, U, W)						
	3-spool position valve, spring-centered	bar	10	14	13	8.5
	2-spool position valve, spring end position	bar	10	14	13	10
	2-spool position valve, hydraulic end position	bar	7	14	8	5
– with pilot oil supply X internal (control spool C, F, H, P, T, V, Z, S ¹⁾)						
		bar	6.5 ²⁾	4.5 ³⁾	4.5 ³⁾	4.5 ³⁾
Pilot volume for switching process						
	3-spool position valve, spring-centered	cm ³	2.04	5.72	14.2	29.4
	2-spool position valve	cm ³	4.08	11.45	28.4	58.8
Pilot volume for shortest switching time	l/min	approx. 35	approx. 35	approx. 35	approx. 45	
Hydraulic fluid	Mineral oil (HL, HLP) according to DIN 51524 ⁴⁾ , fast biodegradable hydraulic fluids according to VDMA 24568 (see also data sheet 90221), HETG (rape seed oil) ⁴⁾ , HEPG (polyglycols) ⁵⁾ , HEES (synthetic esters) ⁵⁾ , flame-resistant hydraulic fluid HFC according to ISO 12922 ⁶⁾ , other hydraulic fluids on request ignition temperature > 180 °C					

Continuation and foot notes, see page 11

Technical data

hydraulic (continued)

Hydraulic fluid temperature range	°C	-20 ... +80 (NBR seals)
		-15 ... +80 (FKM seals)
Viscosity range	mm ² /s	2.8 ... 500
Maximum admissible degree of contamination of the hydraulic fluid, cleanliness class according to ISO 4406 (c)		Class 20/18/15 ⁷⁾

electric

Voltage type		Direct voltage
Available voltages	V	24, 110
Voltage tolerance (nominal voltage)	%	±10
Admissible residual ripple	%	< 5
Duty cycle / operating mode according to VDE 0580		S1 (continuous operation)
Switching time according to ISO 6403		See page 12
Switching frequency	1/h	up to 15000
Nominal power at ambient temperature 20 °C	W	13
Maximum power with 1.1 x nominal voltage and ambient temperature 20 °C	W	15.8
Protection class according to EN 60529		IP 65 with correctly installed connection line

Information on the explosion protection

Area of application as per directive 94/9/EC		I M2, II 2G
Type of protection Valve		c (EN 13463-5:2011)
Maximum surface temperature ⁸⁾	°C	130
Temperature class		T4
Type of protection Valve solenoid according to EN 60079-0:2009 / EN 60079-1:2007		Ex d I Mb Ex d IIC T4 Gb
Type examination certificate Solenoid		BVS 03 ATEX E 300 X
"IEC Certificate of Conformity" Solenoid		IECEX BVS 11.0091 X
Special conditions for safe use		- In case of bank assembly, only one solenoid of all valves may be energized at a time. - In case of valves with two solenoids, maximally one of the solenoids may be energized at a time.
Ambient temperature range	°C	-20 ... +80

¹⁾ Control spool S only for size 16

²⁾ For control spools C, F, G, H, P, T, V, Z, an internal pilot oil supply without preload valve is only possible if the flow from P → T in the central position (for 3-spool position valve) or while crossing the central position (for 2-spool position valve) is so large that the pressure differential of P → T reaches a value of at least 6.5 bar.

³⁾ For control spools C, F, G, H, P, T, V, Z, S ¹⁾ – by means of preload valve (not size 10) or correspondingly high flow.

⁴⁾ Suitable for NBR **and** FKM seals

⁵⁾ Suitable **only** for FKM seals

⁶⁾ If HFC hydraulic fluid is used, the following parameters have to be complied with:

Pressure at P, A, B max. 160 bar, at T max. 3 bar (with E, ET and T) and/or at X max. 160 bar and Y max. 3 bar
Ambient temperature 0 ... 36 °C

Hydraulic fluid temperature max. 55 °C

Duty cycle 60 %

Only NBR seals are admissible.

For more information, please ask our sales staff.

⁷⁾ The cleanliness classes specified for the components must be adhered to in hydraulic systems. Effective filtration prevents faults and at the same time increases the life cycle of the components. For the selection of the filters see www.boschrexroth.com/filter.

⁸⁾ Surface temperature > 50 °C, provide contact protection

Technical data

Switching times (= Contacting at the pilot control valve until start of opening of the control edge in the main valve and change in the control spool stroke by 95 %)

Pilot pressure		bar	70	250	Spring
			ON		OFF
Size 10	without throttle insert	ms	50 ... 70	50 ... 70	30 ... 40
	with throttle insert	ms	70 ... 100	60 ... 80	30 ... 40
Size 16	without throttle insert	ms	60 ... 90	50 ... 70	60 ... 90
	with throttle insert	ms	120 ... 140	90 ... 110	60 ... 90
Size 25	without throttle insert	ms	80 ... 110	60 ... 80	110 ... 140
	with throttle insert	ms	210 ... 260	130 ... 160	110 ... 140
Size 32	without throttle insert	ms	90 ... 140	80 ... 110	150 ... 170
	with throttle insert	ms	430 ... 570	240 ... 360	150 ... 170

Important:

- The switching times are measured according to ISO 6403 with HLP46, $\hat{\theta}_{oil} = 40 \text{ °C} \pm 5 \text{ °C}$. With different oil temperatures, deviations are possible.
- The switching times increase by approx. 30 ms if the pressure reducing valve "D3" is used.
- The switching times have been determined under ideal conditions and may differ in the system, depending on the application conditions.

Free flow cross-sections in zero position with control spools Q, V and W

Control spool	Position	mm ²	13	32	78	83	78
Control spool Q	A - T, B - T	mm ²	13	32	78	83	78
	A - T, B - T	mm ²	13	32	73	83	73
Control spool V	P - A, P - B	mm ²	13	32	84	83	84
	A - T, B - T	mm ²	2.4	6	10	14	20

Electrical connection

The type-examination tested valve solenoid of the valve is equipped with one terminal box and a type-tested cable entry. The connection is polarity-independent.

Important

When establishing the electrical connection, the protective earthing conductor (PE \perp) has to be connected properly.

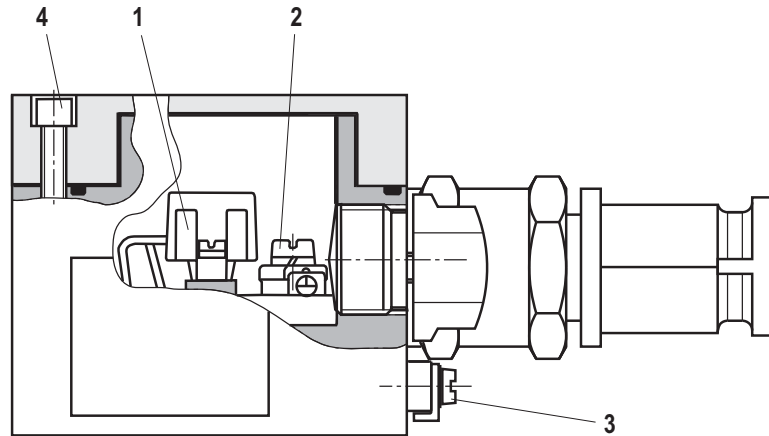

Properties of the connection terminals and mounting elements

Item	Function	Connectable line cross-section
1	Operating voltage connection	Single-wire max. 2.5 mm ² Finely stranded max. 2.5 mm ²
2	Connection for protective earthing conductor	Single-wire 0.75 ... 2.5 mm ² Finely stranded 0.75 ... 1.5 mm ²
3	Connection for potential equalization conductor	Single-wire 4 ... 6 mm ² Finely stranded min. 4 mm ²
4	Screws for cover	-

Cable gland

Line diameter	mm	9...12
Sealing		Outer sheath sealing

Connection line

Line type		Non-armored cables and lines (outer sheath sealing)
Temperature range	°C	-20 ... > +110

Electrical connection (continued)

Circuit diagram

Direct voltage, polarity-independent

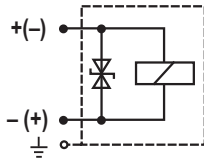

Over-current fuse and switch-off voltage peak

Important

A fuse appropriate for the solenoid's rated current (max. $3 \times I_{\text{rated}}$ according to DIN 41571 and/or IEC 60127) or a protective motor switch with short-circuit and thermal instantaneous tripping must be connected to each valve solenoid as short-circuit protection. The cut-off capacity of this fuse must match or exceed the short-circuit current of the supply source. This fuse or motor protection switch may only be fitted outside the explosive area or must be of an explosion-proof design.

When inductivities are switched off, voltage peaks result which may cause failures in the connected control electronics. For this reason, the valve solenoids comprise a suppression circuit which dampens this voltage peak to the voltage value shown in the table.

Voltage data in the valve type code	Nominal voltage Valve solenoid	Rated current Valve solenoid	Recommended pre-fuse characteristics medium time-lag according to DIN 41571	Maximum voltage value upon switch-off	Suppression circuit
G24	24 V DC	0.542 A DC	630 mA	-90 V	Suppressor diode bi-directional
G110	110 V DC	0.118 A DC	125 mA	-390 V	

Characteristic curves: Type H-4WEH 10... (measured with HLP46, $\dot{v}_{oil} = 40 \text{ }^\circ\text{C} \pm 5 \text{ }^\circ\text{C}$)

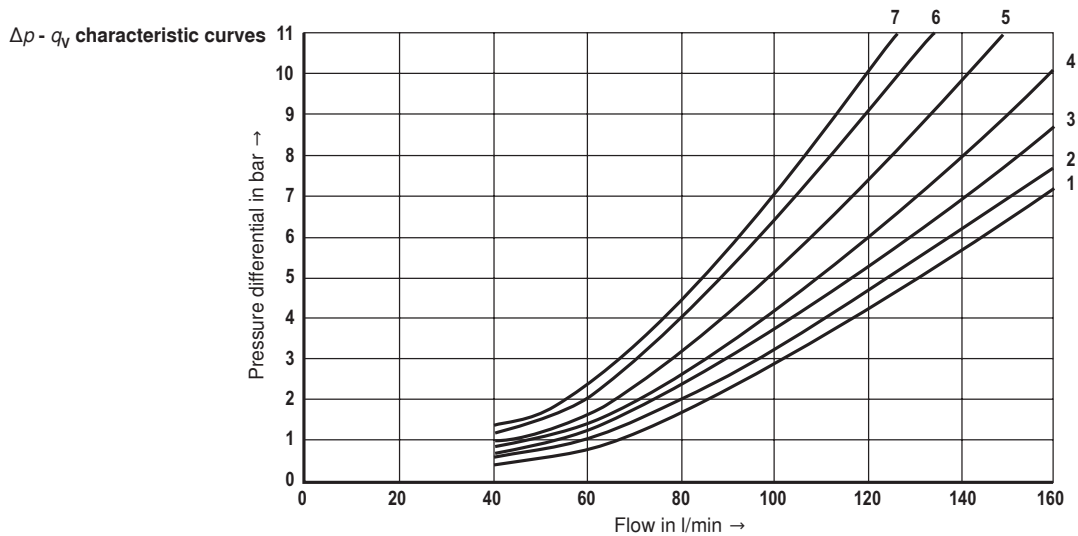

Characteristic curve selection

Control spool	Spool position				Control spool	Zero position		
	P - A	P - B	A - T	B - T		A - T	B - T	P - T
E, Y, D	2	2	4	5				
F	1	4	1	4	F	3	-	6
G, T	4	2	2	6	G, T	-	-	7
H, C	4	4	1	4	H	1	3	5
J, K	1	2	1	3				
L	2	3	1	4	L	3	-	-
M	4	4	3	4				
P	4	1	3	4	P	-	7	5
Q, V, W, Z	2	2	3	5				
R	2	2	3	-				
U	3	3	3	4	U	-	4	-

Performance limits: Type H-4WEH 10... (measured with HLP46, $\dot{v}_{oil} = 40 \text{ }^\circ\text{C} \pm 5 \text{ }^\circ\text{C}$)

2- and 3-spool position valves

Maximum flow q_v in l/min

Control spool	Operating pressure p_{max} in bar		
	200	250	315
E, J, L, M, Q, R, U, V, W, C, D, K, Z, Y	160	160	160
H	160	150	120
G, T	160	160	140
F, P	160	140	120

Important

The specified switching power limits are valid for operation with two directions of flow (e. g. P → A and simultaneous return flow B → T) in the ratio 1:1.

Due to the flow forces acting within the valves, the admissible switching power limit may be considerably lower with only one direction of flow (e. g. P → A while port B is blocked)!

(In such cases, please consult us!)

The switching power limit was established while the solenoids were at operating temperature, at 10 % undervoltage and without tank pre-loading.

Characteristic curves: Type H-4WEH 16... (measured with HLP46, $\vartheta_{oil} = 40 \text{ }^\circ\text{C} \pm 5 \text{ }^\circ\text{C}$)

$\Delta p - q_v$ characteristic curves

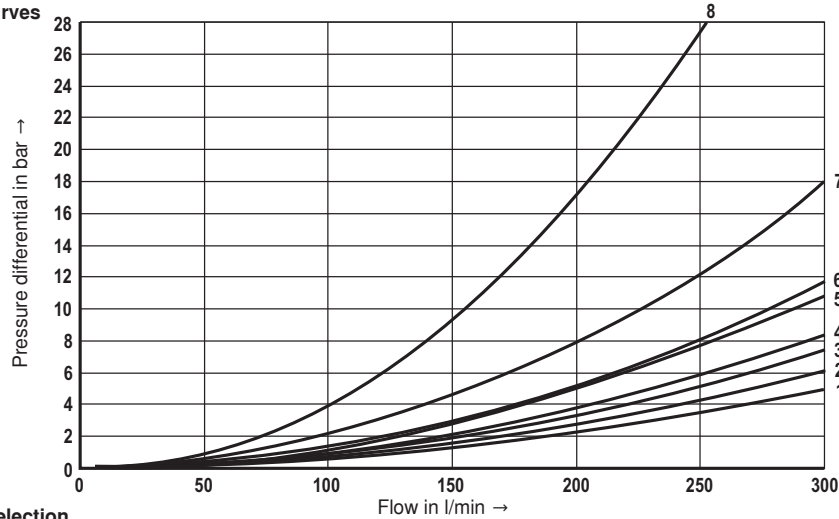

Characteristic curve selection

Control spool	Spool position				
	P-A	P-B	A-T	B-T	P-T
E, Y, D	1	1	3	4	-
F	1	1	5	4	-
G, T	4	1	5	5	7
H, C, Q, V, Z	1	1	5	6	-
J, K, L	1	1	5	6	-

Control spool	Spool position				
	P-A	P-B	A-T	B-T	P-T
M, W	1	1	3	4	-
R	1	1	3	-	-
U	2	2	3	5	-
S	3	3	3	-	8

Performance limits: Type H-4WEH 16... (measured with HLP46, $\vartheta_{oil} = 40 \text{ }^\circ\text{C} \pm 5 \text{ }^\circ\text{C}$)

2-spool position valve

Maximum flows q_v in l/min

Control spool	Operating pressure p_{max} in bar				
	70	140	210	280	350

X external, spring end position in the main valve

(with $p_{St min} = 12 \text{ bar}$)

	70	140	210	280	350
--	----	-----	-----	-----	-----

X external, spring end position in the main valve ¹⁾

	70	140	210	280	350
C	300	300	300	300	300
D, Y	300	270	260	250	230
K	300	250	240	230	210
Z	300	260	190	180	160

X external, hydraulic end position in the main valve

	70	140	210	280	350
HC, HD, HK, HZ, HY	300	300	300	300	300

Important

See also "Important" page 15

3-spool position valve

Maximum flows q_v in l/min

Control spool	Operating pressure p_{max} in bar				
	70	140	210	280	350

X external, spring centering in the main valve

	70	140	210	280	350
E, H, J, L, M, Q, U, W, R	300	300	300	300	300
F, P	300	250	180	170	150
G, T	300	300	240	210	190
S	300	300	300	250	220
V	300	250	210	200	180

Important

¹⁾ If the specified flow values are exceeded, the function of the return spring is no longer guaranteed if the pilot pressure fails!

- With pilot oil supply **X internal**, you must always use a preload valve due to the negative overlap of the control spools F, G, H, P, T, S, C and HC.
- With control spools V, Z and HZ, the preload valve is **not** required for flows > 180 l/min.

Characteristic curves: Type H-4WEH 25... (measured with HLP46, $\vartheta_{oil} = 40 \text{ }^\circ\text{C} \pm 5 \text{ }^\circ\text{C}$)

$\Delta p - q_v$ characteristic curves

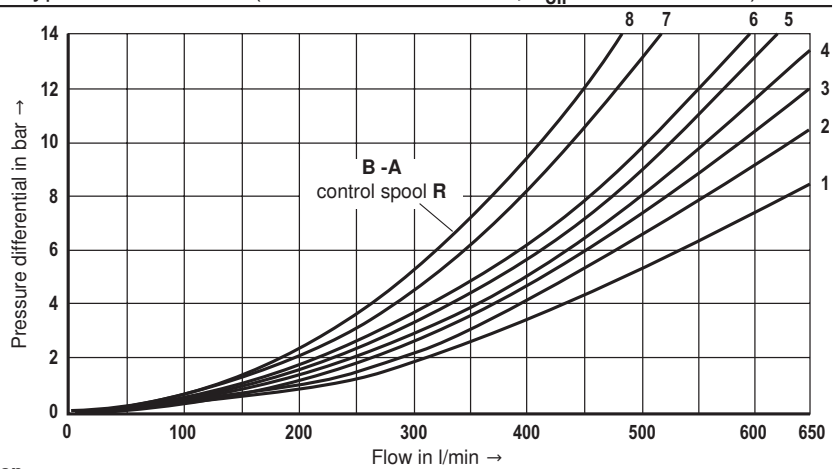

- 7 Control spool G
Central position P – T
- 8 Control spool T
Central position P – T

Characteristic curve selection

Control spool	Spool position				Control spool	Spool position				Control spool	Spool position			
	P – A	P – B	A – T	B – T		P – A	P – B	A – T	B – T		P – A	P – B	A – T	B – T
E	1	1	1	3	L	2	2	3	3	U	4	1	1	6
F	1	4	3	3	M	4	4	1	4	V	2	4	3	6
G	3	1	2	4	P	4	1	1	5	W	1	1	1	3
H	4	4	3	4	R	2	1	1	-	T	3	1	2	4
J, Q	2	2	3	5										

Performance limits: Type H-4WEH 25... (measured with HLP46, $\vartheta_{oil} = 40 \text{ }^\circ\text{C} \pm 5 \text{ }^\circ\text{C}$)

2-spool position valve

Maximum flows q_v in l/min

Control spool	Operating pressure p_{max} in bar				
	70	140	210	280	350
X external, spring end position in the main valve (with $p_{St min} = 13 \text{ bar}$)					
C, D, K, Y, Z	700	700	700	700	650
X external, spring end position in the main valve ¹⁾					
C	700	700	700	700	650
D, Y	700	650	400	350	300
K	700	650	420	370	320
Z	700	700	650	480	400
X external, hydraulic end position in the main valve					
HC, HD, HK, HZ, HY	700	700	700	700	700
HC../O.. HD../O.. HK../O.. HZ../O..	700	700	700	700	700
HC../OF.. HD../OF.. HK../OF.. HZ../OF..	700	700	700	700	700

Important

See also "Important" page 15

3-spool position valve

Maximum flows q_v in l/min

Control spool	Operating pressure p_{max} in bar				
	70	140	210	280	350
X external, spring centering in the main valve					
E, L, M, Q, U, W,	700	700	700	700	650
G, T	400	400	400	400	400
F	650	550	430	330	300
H	700	650	550	400	360
J	700	700	650	600	520
P	650	550	430	330	300
V	650	550	400	350	310
R	700	700	700	650	580

Important

¹⁾ If the specified flow values are exceeded, the function of the return spring is no longer guaranteed if the pilot pressure fails!

- With pilot oil supply **X internal**, a preload valve has to be used for flows < 180 l/min due to the negative overlap of the control spools Z, HZ and V.
- With pilot oil supply **X internal**, you must always use a preload valve due to the negative overlap of the control spools C, HC, F, G, H, P and T.

Characteristic curves: Type H-4WEH 32... (measured with HLP46, $\vartheta_{oil} = 40 \text{ }^\circ\text{C} \pm 5 \text{ }^\circ\text{C}$)

$\Delta p - q_v$ characteristic curves – Control spools E, R and W

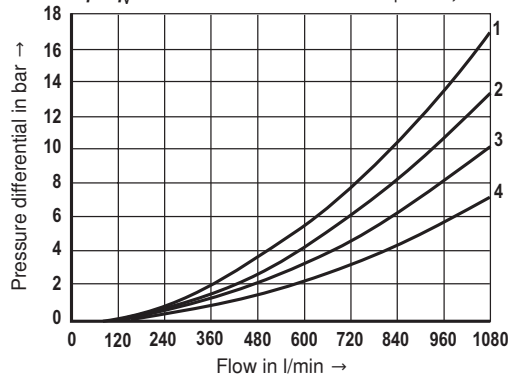

$\Delta p - q_v$ characteristic curves – Control spools G and T

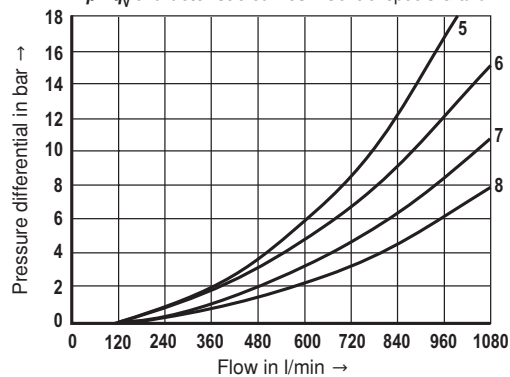

$\Delta p - q_v$ characteristic curves – All remaining control spools

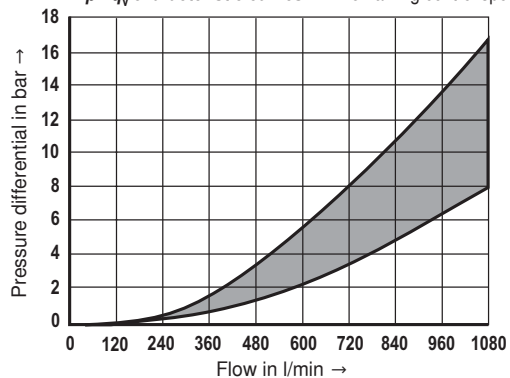

Control spool	Spool position				
	P-A	P-B	A-T	B-T	B-A
E	4	4	3	2	-
R	4	4	3	-	1
W	4	4	3	2	-

Control spool	Spool position				
	P-A	P-B	A-T	B-T	P-T
G	7	8	7	5	6
T	7	8	7	5	6

Performance limits: Type H-4WEH 32... (measured with HLP46, $\vartheta_{oil} = 40 \text{ }^\circ\text{C} \pm 5 \text{ }^\circ\text{C}$)

2-spool position valve

Maximum flows q_v in l/min

Control spool	Operating pressure p_{max} in bar				
	70	140	210	280	350
X external, spring end position in the main valve (with $p_{St min} = 10 \text{ bar}$)					
C, D, K, Y, Z	1100	1040	860	750	680
X external, spring end position in the main valve ¹⁾					
C	1100	1040	860	800	700
D, Y	1100	1040	540	480	420
K	1100	1040	860	500	450
Z	1100	1040	860	700	650
X external, hydraulic end position in the main valve					
HC, HD, HK, HZ, HY	1100	1040	860	750	680

3-spool position valve

Maximum flows q_v in l/min

Control spool	Operating pressure p_{max} in bar				
	70	140	210	280	350
X external, spring centering in the main valve					
E, J, L, M, Q, U, W, R	1100	1040	860	750	680
G, T, H, F, P	900	900	800	650	450
V	1100	1000	680	500	450

Important

See also "Important" page 15

Important

¹⁾ If the specified flow values are exceeded, the function of the return spring is no longer guaranteed if the pilot pressure fails!

- With pilot oil supply **X internal**, a preload valve has to be used for flows < 180 l/min due to the negative overlap of the control spools Z, HZ and V.
- With pilot oil supply **X internal**, you must always use a preload valve due to the negative overlap of the control spools C, HC, F, G, H, P and T.

Switching time adjustment, pressure reducing valve, preload valve

Switching time adjustment "S/S2"

The switching time of the main valve (1) is influenced by using a twin throttle check valve (2), type Z2FS 6.

Symbol (3) shows the switching time adjustment "S" (supply control), symbol (4) shows the switching time adjustment "S2" (discharge control)

Type H-4WEH 10 ..4X/...S or S2

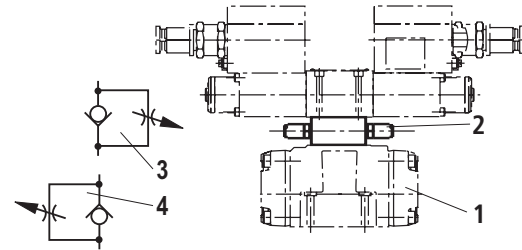

Pressure reducing valve "D3"

With the design internal pilot oil supply (ET or E) or external pilot oil supply and a pilot pressure of more than 250 bar, the valve must be ordered with a pressure reducing valve (3), type ZDR6PO, and a throttle insert "B10".

Ordering code: "B10..D3"

Type H-4WEH 10 ..4X/.../...D3

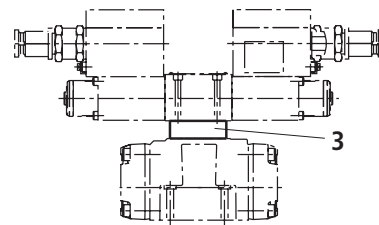

Preload valve "P4,5" (not for size 10)

In case of valves with depressurized circulation and internal pilot oil supply, a preload valve is necessary in the P channel of the main valve in order to build up the minimum pilot pressure.

Ordering code: "P4,5"

The pressure differential of the preload valve is to be added to the pressure differential of the main valve (see characteristic curves) to result in one total value.

The cracking pressure amounts to approx. 4.5 bar.

$\Delta p - q_v$ characteristic curve

(measured with HLP46, $\vartheta_{Oil} = 40 \text{ }^\circ\text{C} \pm 5 \text{ }^\circ\text{C}$)

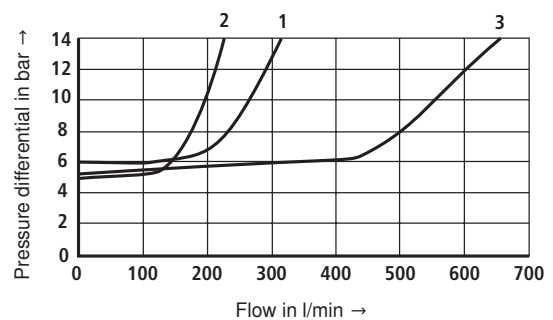

1 = Size 16 2 = Size 25 3 = Size 32

Device dimensions: Type H-4WEH 10... (dimensions in mm)

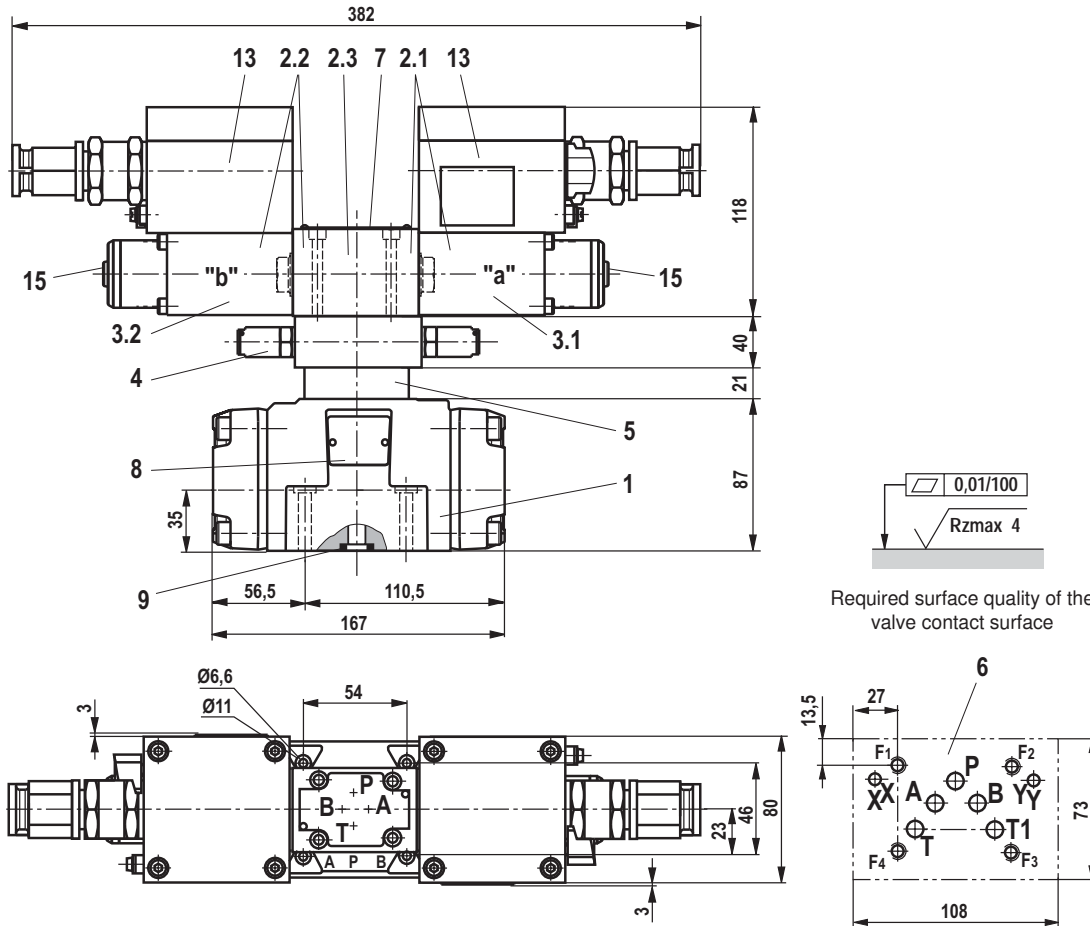

Subplates

- **without** ports X, Y G 534/01 FE/ZN (G3/4)
- **with** ports X, Y G 535/01 FE/ZN (G3/4)
G 536/01 FE/ZN (G1)

with dimensions as in the data sheet 45054
(must be ordered separately)

Item explanations and information on the subplates,
see page 24

Valve mounting screws

For reasons of stability, exclusively use the following valve
mounting screws:

4 hexagon socket head cap screws
ISO 4762-M6x45-10.9-fZn-240h-L
(friction coefficient total: 0.09-0.14 according to VDA 235-101)
(must be ordered separately)

Device dimensions: Type H-4WEH 16... (dimensions in mm)

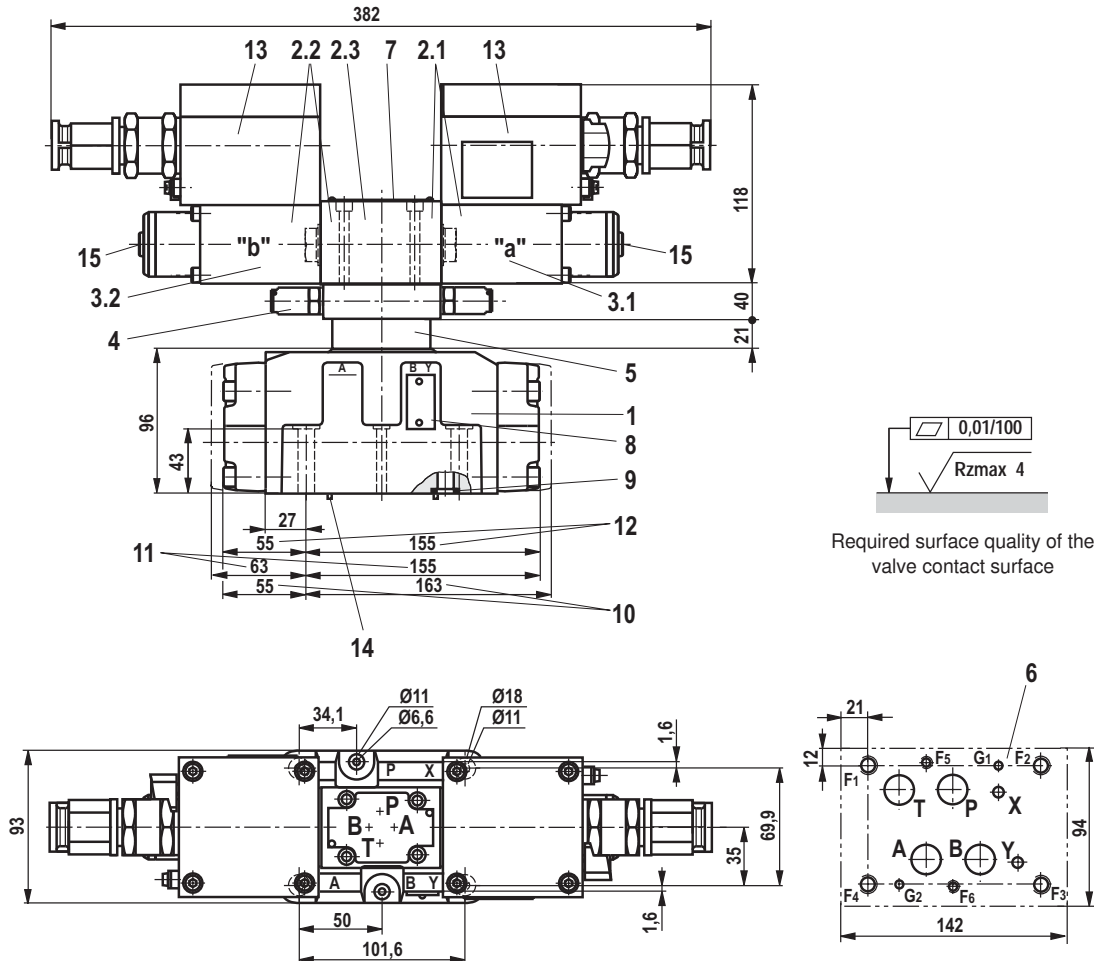

Subplates

- G 172/01 FE/Zn (G3/4)
- G 172/02 FE/Zn (M27 x 2)
- G 174/01 FE/Zn (G1)
- G 174/02 FE/Zn (M33 x 2)
- G 174/08 FE/Zn (flange)

with dimensions as in the data sheet 45056
(must be ordered separately)

Item explanations and information on the subplates,
see page 24

Valve mounting screws

For reasons of stability, exclusively use the following valve
mounting screws:

4 hexagon socket head cap screws
ISO 4762-M10x60-10.9-flZn-240h-L
(friction coefficient total: 0.09-0.14 according to VDA 235-101)

2 hexagon socket head cap screws
ISO 4762-M6x60-10.9-flZn-240h-L
(friction coefficient total: 0.09-0.14 according to VDA 235-101)
(must be ordered separately)

Device dimensions: Type H-4WEH 25... (dimensions in mm)

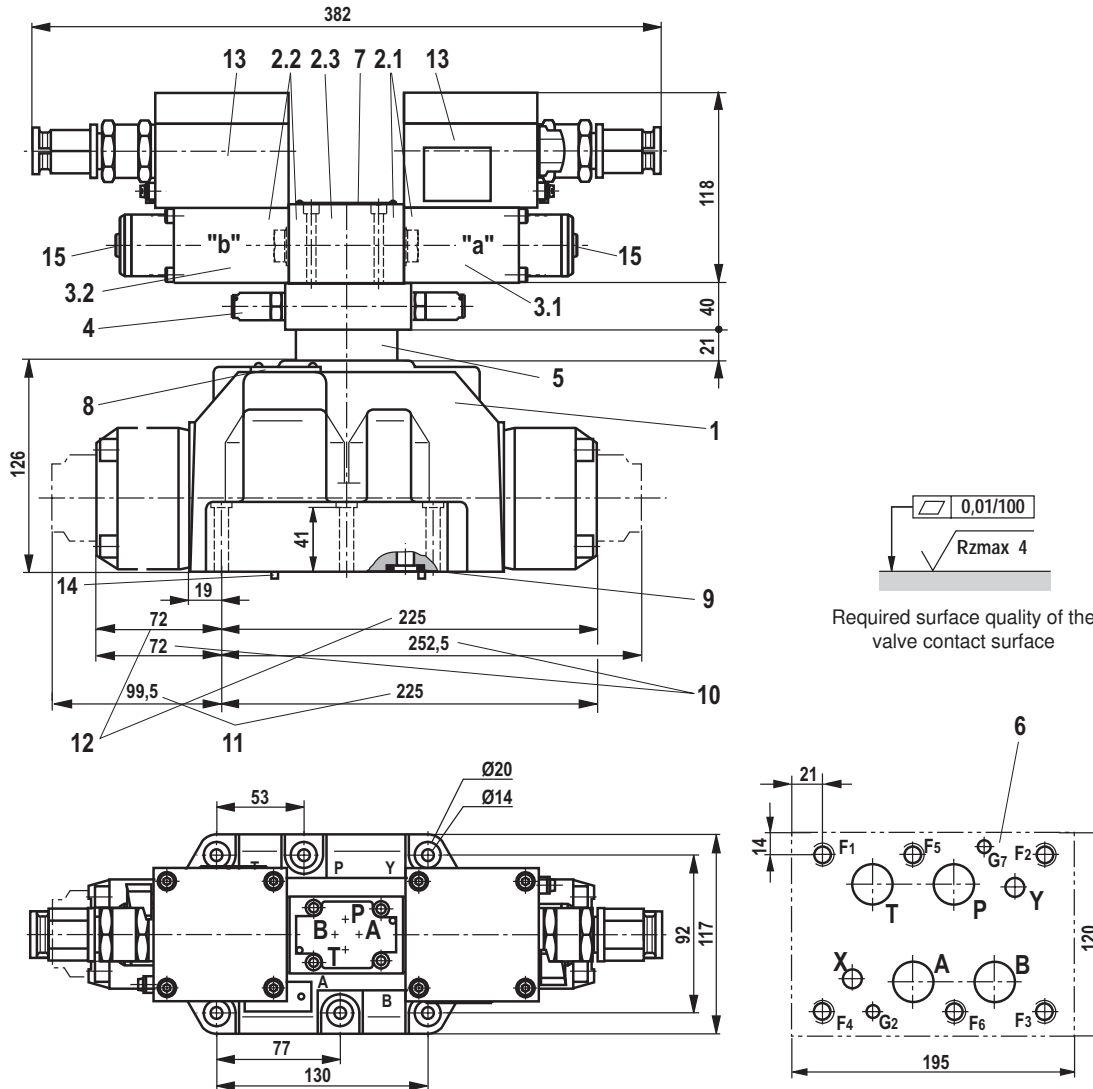

Subplates

- G 151/01 FE/Zn (G1)
- G 154/01 FE/Zn (G1 1/4)
- G 154/08 FE/Zn (flange)
- G 156/01 FE/Zn (G1 1/2)

with dimensions as in the data sheet 45058
(must be ordered separately)

Item explanations and information on the subplates,
see page 24

Valve mounting screws

For reasons of stability, exclusively use the following valve
mounting screws:

6 hexagon socket head cap screws

ISO 4762-M12x60-10.9-flZn-240h-L

(friction coefficient total: 0.09-0.14 according to VDA 235-101)

(must be ordered separately)

Device dimensions: Type H-4WEH 32... (dimensions in mm)

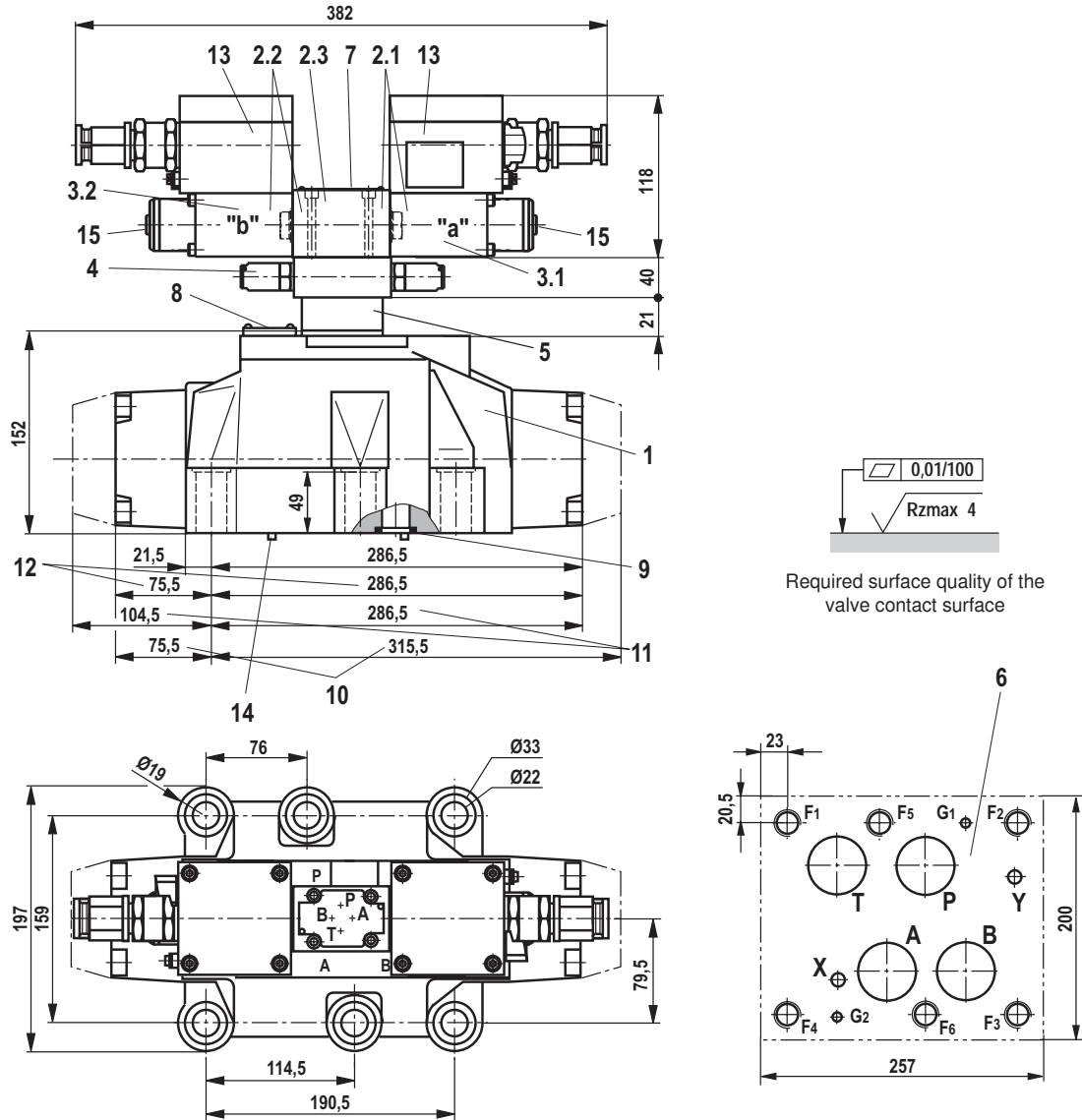

Subplates

- G 157/01 FE/Zn (G1 1/2)
- G 157/02 FE/Zn (M48 x 2)
- G 158/10 FE/Zn (flange)

with dimensions as in the data sheet 45060
(must be ordered separately)

Item explanations and information on the subplates,
see page 24

Valve mounting screws

For reasons of stability, exclusively use the following valve
mounting screws:

6 hexagon socket head cap screws
ISO 4762-M20x80-10.9-flZn-240h-L

(friction coefficient total: 0.09-0.14 according to VDA 235-101)
(must be ordered separately)

Device dimensions: Item explanations and notice

Item explanations regarding the device dimensions on pages 20 to 23

- | | |
|---|---|
| <ul style="list-style-type: none">1 Main valve2 Pilot control valve type 4WE 6...XE according to technical data sheet 23178-XE-B22.1 • Pilot control valve type 4WE 6 D... (1 solenoid "a")
For main valves with Control spools C, D, K, Z
Control spool HC, HD, HK, HZ• Pilot control valve type 4WE 6 JA... (1 solenoid "a")
For main valves with control spools EA, FA, etc., spring return2.2 • Pilot control valve type 4WE 6 Y... (1 solenoid "b")
For main valves with Control spool Y
Control spool HY• Pilot control valve type 4WE 6 JB... (1 solenoid "b")
For main valves with control spools EB, FB, etc., spring return2.3 • Pilot control valve type 4WE 6J... (2 solenoids)
For main valves with 3 spool positions, spring-centered3.1 Valve solenoid "a"3.2 Valve solenoid "b"4 Switching time adjustment, optional5 Pressure reducing valve, optional | <ul style="list-style-type: none">6 Processed valve contact surface
Porting pattern according to:
DIN 24340-A10 and
ISO 4401-05-05-0-05 for size 10
DIN 24340-A16 and
ISO 4401-07-07-0-05 for size 16
DIN 24340-A25 and
ISO 4401-08-08-0-05 for size 25
DIN 24340-A32 and
ISO 4401-10-09-0-05 for size 327 Name plate for the pilot control valve8 Name plate for the complete valve9 R-rings/O-rings10 2-spool position valves with spring end position in the main valve (C, D, K, Z)11 2-spool position valves with spring end position in the main valve (Y)12 3-spool position valves, spring-centered
2-spool position valves with hydraulic end position in the main valve13 Terminal box14 Locking pin15 Manual override "N" |
|---|---|

Important:

Subplates are no components in the sense of directive 94/9/EC and can be used after the manufacturer of the overall system has assessed the risk of ignition.

The G...FE/ZN versions are free from aluminum and/or magnesium and galvanized.

© This document, as well as the data, specifications and other information set forth in it, are the exclusive property of Bosch Rexroth AG. It may not be reproduced or given to third parties without its consent. The data specified above only serve to describe the product. No statements concerning a certain condition or suitability for a certain application can be derived from our information. The information given does not release the user from the obligation of own judgment and verification. It must be remembered that our products are subject to a natural process of wear and aging.