

Three-position swing cylinder *Application & selection*

Collet-Lok® products

Swing clamps

Shown: WTR-24



WTR series

The three position swing cylinder rotates 90° only after the plunger has completely extended. This feature allows the clamp to be mounted beneath the workpiece, where the clamp travels through the part for clamping.

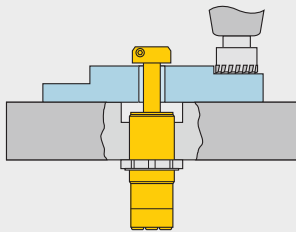

Unobstructed part loading

- Plunger rotates only when cylinder is fully extended, to minimize obstructions
- Ideal for mounting beneath the fixture, as the clamp does not rotate until the workpiece has been cleared
- Stainless steel body for additional corrosion resistance
- Three port design for fewer hydraulic connections
- Fully threaded body for easy installation
- Standard two sided clamp arm included
- Clamp arm design makes mounting easy.

Operation sequence

The three position swing cylinder is ideal for parts which have a through hole. The clamp allows completely unobstructed part loading.

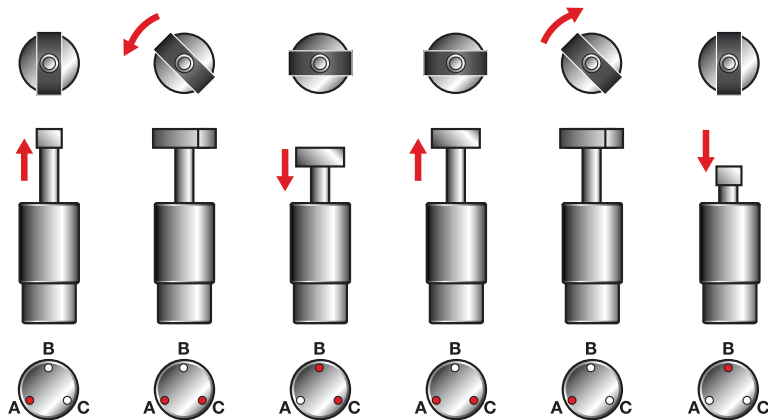

- Step 1**
Pressurize port A.
Plunger extends through workpiece.
- Step 2**
Keep port A pressurized.
Pressurize port C.
Plunger makes 90° flat rotation.
- Step 3**
Keep port C pressurized.
Pressurize port B.
Plunger retracts: clamp force is applied.
- Step 4**
Keep port C pressurized.
Pressurize port A.
Plunger extends: clamp force is released.
- Step 5**
Keep port A pressurized.
Depressurize port C.
Plunger makes 90° flat rotation.
- Step 6**
Pressurize port B.
Plunger retracts through workpiece.

Selection chart

Clamping force ¹⁾	Stroke	Model number ²⁾	Cylinder effective area		Oil capacity		Max. oil flow	Maximum cycle rate
			cm ² Clamp.	cm ² Unclamp.	cm ³ Clamp.	cm ³ Unclamp.		
kN	mm						l/min	cycles /min
22,2	63,5	WTR-24	6,3	11,4	41,0	72,1	1,9	4

¹⁾ When using optional CA-28 clamp arm, max. operating pressure is 138 bar.

²⁾ Standard clamp arm included.

* This product is made to order. Please contact Enerpac for delivery information before specifying in your design.

Dimensions & options WTR-series

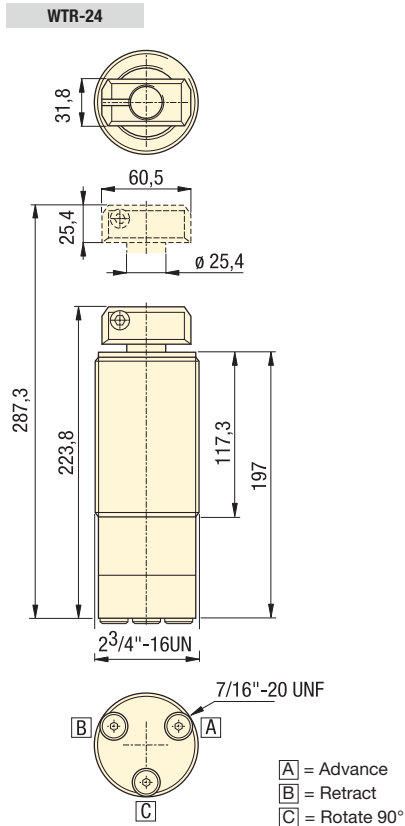

i Optional CA-28 clamp arm

The WTR-24 has a two-sided standard clamp arm included. The CA-28 clamp arm can be used to secure the workpiece on one side only, though the clamping pressure must be reduced to 140 bar maximum.

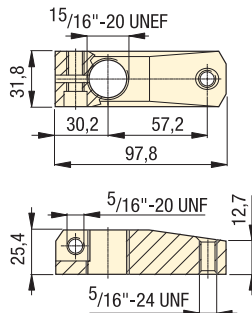

Force: 8,7 - 22,2 kN

Stroke: 63,5 mm

Pressure: 140 - 350 bar

- E** Cilindros giratorios
- F** Vérins de bridage pivotants
- D** Schwenkspannzylinder



i Options

High pressure filters

193



Fittings

194



Valves

136



w Important

It is highly recommended that system filtration be used to ensure reliable operation.

Do not exceed maximum pressure and flow rates.

For recommended valving schemes, please refer to page 42.

Clamp arm movement:
90° ± 3° flat rotation.

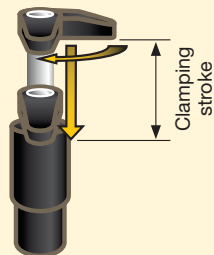

ENERPAC

41

Swing Clamps

Work Supports

Linear Cylinders

Power Sources

Valves

Pallet Components

System Components

Yellow Pages

WTR-series schematics

Collet-Lok® products
Swing clamps

⚠ Important

Circuit must include a Pressure Reducing Valve (PRV-4) in the "A" port circuit to reduce the pressure in Unclamp to prevent damage to the cylinder.

Recommended valving system for WTR-24

- 4-way 3-position closed center valves are recommended
- Valves can be manual or solenoid operated
- Valves must be cycled as shown for proper actuation of the WTR-24.

