

Electric Drives
and Controls

Hydraulics

Linear Motion and
Assembly Technologies

Pneumatics

Service

Rexroth
Bosch Group

Proportional pressure reducing valve, pilot operated

RE 29276/03.11
Replaces: 01.10

1/16

Type DRE(M) and DRE(M)E

Sizes 10 and 25 ¹⁾
Component series 6X
Maximum operating pressure 315 bar
Maximum flow 300 l/min

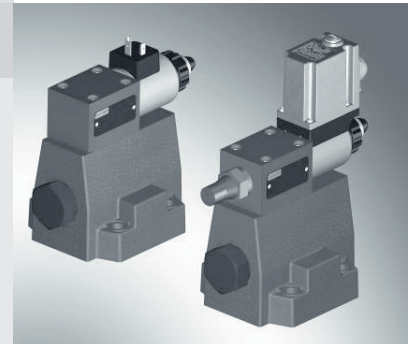

Table of contents

Contents	Page
Features	1
Ordering code	2
Symbols	3
Function, section	4 and 5
Technical data	6 and 7
Electrical connection, mating connectors	8
Control electronics	9
Characteristic curves	10 and 11
Unit dimensions	12 to 14

Features

- Valve for reducing an operating pressure
- Operation by means of proportional solenoids
- Proportional solenoid with rotatable and detachable coil
- For subplate mounting:
Porting pattern according to ISO 5781,
Subplates according to data sheet RE 45062
(separate order), see page 11
- Third path A to Y (Ø 7.5 mm)
- Minimum setting pressure 2 bar with command value zero
- Linearized command value-pressure characteristic curve
- Good transient response
- Optional check valve between A and B
- Maximum pressure limitation optional
- Type DRE(M)E with integrated electronics (OBE):
 - Little manufacturing tolerance of the command value-pressure characteristic curve

¹⁾ Size 32 see data sheet RE 29278

Ordering code

DRE			-6X/	Y		G24				*
without maximum pressure limitation	= no code									Further details in the plain text
with maximum pressure limitation ¹⁾	= M									
For external control electronics	= no code									Seal material M = NBR seals V = FKM seals
with integrated electronics (OBE)	= E									
Size 10	= 10									Interface electronics A1 = Command value 0 to 10 V F1 = Command value 4 to 20 mA no code = with DRE
Size 25	= 20									
Component series 60 to 69 (60 to 69: Unchanged installation and connection dimensions)	= 6X									Electrical connection for DRE(M): K4 = without mating connector, with connector according to DIN EN 175301-803 Mating connector - separate order see page 8 for DRE(M)E: K31 = without mating connector, with connector according to DIN EN 175201-804 Mating connector - separate order see page 8
Pressure rating 50 bar 100 bar 200 bar 315 bar	 = 50 = 100 = 200 = 315									
Pilot oil return always external separately and at zero pressure to the tank	= Y									no code = 1600 mA design - 8 = 800 mA design ²⁾
with check valve between A and B	= no code									
without check valve	= M									Supply voltage of the control electronics G24 = Direct voltage 24 V

Accessories (not included in scope of delivery)

- External control for type DRE (only standard version G24 (1.6 A solenoid)):
 - Analog amplifier VT-MSPA1-11-1X/ in modular design according to data sheet RE 30223
 - Digital amplifier VT-VSPD-2 in Eurocard format according to data sheet RE 30523
 - Analog amplifier VT-VSPA1-11-1X/ in Eurocard format according to data sheet RE 30100
 - Proportional plug-in amplifier VT-SSPA1-1-1X plug-in amplifier according to data sheet RE 30116 connection M12 - 4-pole
- Mating connectors (details, see page 8)
 - For DRE(M): According to DIN EN 175301-803, Material no. **R901017011**
 - For DRE(M)E: According to DIN EN 175201-804, Material no. **R900021267** or **R900223890**

¹⁾ In case of an error (e.g. in case of contamination or overcurrent), the maximum pressure limitation prevents an inadmissibly high overpressure at the valve.

²⁾ Replacement series 5X (Attention! External amplifiers only suitable for G24 = 1.6 A solenoid), see accessories.

Symbols

DRE -6X/...YM...

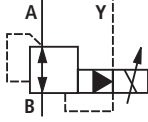

DREM -6X/...YM...

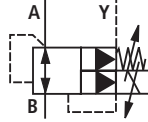

DRE -6X/...Y...

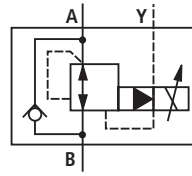

DREM -6X/...Y...

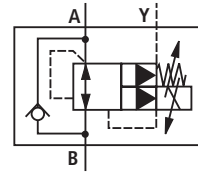

DREE -6X/...YM...

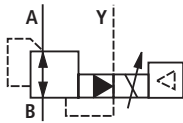

DREME -6X/...YM...

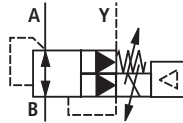

DREE -6X/...Y...

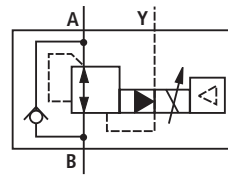

DREME -6X/...Y...

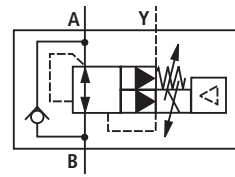

Function, section

Valves of type DRE(M) are pilot controlled pressure reducing valves. They are used for reducing an operating pressure.

These valves basically comprise of a pilot control valve (1) with proportional solenoid (2), main valve (3) with main spool insert (4), as well as an optional check valve (5).

Type DRE...

The pressure in channel A is set in a command value-dependent form via the proportional solenoid (2).

In rest position - no pressure in channel B -, the spring (17) holds the main spool (4) in its initial position. The connection from channel B to A is closed. A start-up jump is thus suppressed.

Via the bore (6), the pressure in channel A acts on the surface (7) of the main spool. The pilot oil is taken from channel B and flows via the bore (8) to the constant flow controller (9) keeping the pilot flow constant, independent of the pressure drop between channel A and B. From the constant flow controller (9), the pilot flow flows into the spring chamber (10), through the bores (11) and (12) via the valve seat (13) into the Y channel (14, 15, 16) and from there to the return.

The pressure required in channel A is preset at the related amplifier. The proportional solenoid moves the valve poppet (20) in the direction of the valve seat (13) and limits the pressure in the spring chamber (10) to the set value. If the pressure in channel A is lower than the specified command value, the higher pressure in the spring chamber (10) pushes the main spool to the right. The connection from B to A is opened.

If the set pressure in A is achieved, the forces at the main spool are balanced - the main spool is in control position.

Pressure in channel A • Spool face (7) =
Pressure in the spring chamber (10) • Spool face – Spring force (17)

If in a standing hydraulic fluid column (e.g. cylinder piston to stop), the pressure in A is to be reduced, a lower command value is (e.g.) specified at the control electronics and thus, a lower pressure is pre-selected that is immediately applied to the spring chamber (10). The higher pressure in A at the face (7) of the main spool pushes the main spool against the plug screw (18) to stop. The connection A to B is blocked and A to Y is open. The force of spring (17) now acts against the hydraulic force at the face (7) of the main spool. In this main spool position, the hydraulic fluid can flow from channel A via the control edge (19) to Y into the return.

If the pressure in A has been reduced to the pressure in the spring chamber (10) plus Δp from spring (17), the main spool at the control edge A to Y closes the large control bores in the socket.

The remaining differential pressure of approx. 10 bar to the new command value pressure in A is only discharged via the fine control bore (21). This results in a good transient response without pressure undershoots.

For the free return flow from channel A to B, a check valve (5) can optionally be installed. A part of this flow from channel A simultaneously flows via the open control edge (19) of the main spool from A to Y into the return.

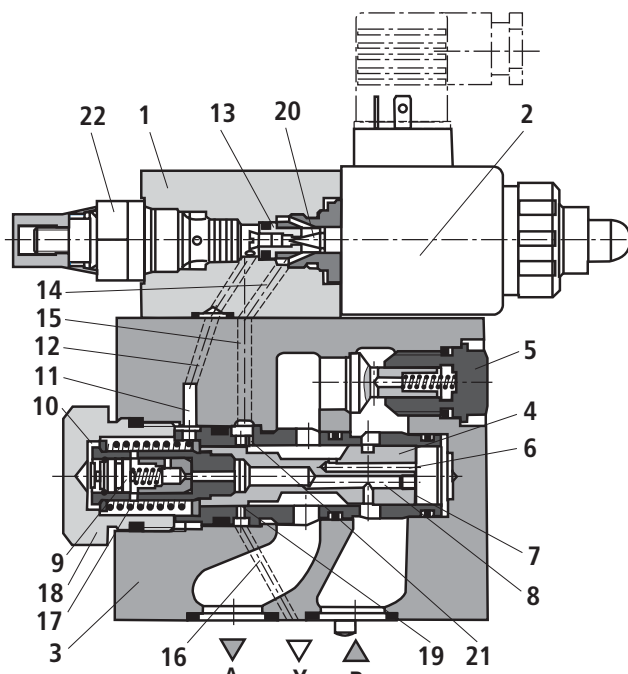

Type DREM...-6X/...YG24K4... (with check valve)

Type DREM...

For hydraulic protection against an inadmissibly high electric control current at the proportional solenoid, which imperatively results in increased pressures in port A, you can optionally install a spring-loaded pressure relief valve as maximum pressure limitation (22). The maximum pressure limitation is pre-set referred to the relevant pressure rating (table page 6).

Function, section

Type DRE(M) – with integrated electronics (OBE)

With regard to function and structure, these types correspond to type DRE. On the proportional solenoid, there is moreover a housing (23) with the control electronics.

Supply and command value voltage are applied at the connector (24).

In the factory, the command value pressure characteristic curve is adjusted with little manufacturing tolerance.

For more information on the control electronics see page 8.

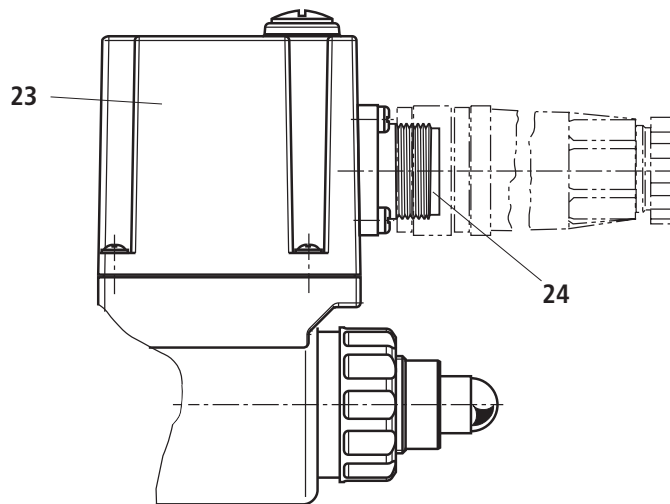

Type DRE(M)E...-6X/...YG24K31...

Technical Data (For applications outside these parameters, please consult us!)

general

Size	Size	10	25	
Weight	- DRE and DREM	kg	4.7	6.0
	- DREE and DREME	kg	4.8	6.1
Installation position		Any		
Storage temperature range		°C -20 to +80		
Ambient temperature range	- DRE(M)	°C -20 to +70		
	- DRE(M)E	°C -20 to +50		

hydraulic (measured with HLP 46, $\vartheta_{oil} = 40 \text{ °C} \pm 5 \text{ °C}$)

Size	Size	10	25	
Max. operating pressure	- Port A and B	bar	315	
	- Port Y		Separately and to the tank at zero pressure (internal pipe $\varnothing \geq 5 \text{ mm}$; pipe length < 2500 mm)	
Max. setting pressure in channel A	- Pressure rating 50 bar	bar	50	
	- Pressure rating 100 bar	bar	100	
	- Pressure rating 200 bar	bar	200	
	- Pressure rating 315 bar	bar	315	
Min. setting pressure in channel A with command value zero		bar	2	
Maximum pressure limitation (fixedly set)		Set in the factory:		
	- Pressure rating 50 bar	bar	To 70 bar	
	- Pressure rating 100 bar	bar	To 130 bar	
	- Pressure rating 200 bar	bar	To 230 bar	
	- Pressure rating 315 bar	bar	To 350 bar	
Max. flow of the main valve		l/min	200	300
Pilot flow		l/min	0.8	
Hydraulic fluid		On mineral oil basis and related hydrocarbons (HL, HLP, HLPD, HLPP) according to DIN 51524 ¹⁾ Flame-resistant – water-free (HFDU(G), HFDU(E), HFDR) according to ISO12922 ^{2), 4)} Flame-resistant – containing water (HFC: Fuchs Hydrotherm 46M, Petrofer Ultra Safe 620) according to ISO12922 ^{3), 4)}		
Hydraulic fluid temperature range		°C	-20 to +80	
Viscosity range		mm ² /s	15 to 380	
Max. admissible degree of contamination of the hydraulic fluid Cleanliness class according to ISO 4406 (c)			Class 20/18/15 ⁵⁾	
Hysteresis		%	± 3.5 of the max. setting pressure ⁶⁾	
Repeatability		%	< ± 2 of the max. setting pressure ⁶⁾	
Linearity		%	± 2 of the max. setting pressure ⁶⁾	
Manufacturing tolerance of the command value pressure characteristic curve, related to the hysteresis characteristic curve, pressure increasing	- DRE(M)	%	± 3.5 of the max. setting pressure ⁶⁾	
	- DRE(M)E	%	± 1.5 of the max. setting pressure ⁶⁾	
Step response $T_u + T_g$	10 → 90 %	ms	~130	Measured with standing hydraulic fluid column,
	90 → 10 %	ms	~160	1 liter at port A
Step response $T_u + T_g$	10 → 90 %	ms	~150	Measured with standing hydraulic fluid column,
	90 → 10 %	ms	~150	5 liters at port A

Foot notes see next page

Technical Data (For applications outside these parameters, please consult us!)

- 1) Suitable with NBR **and** FKM seals
 2) Suitable **only** with FKM seals
 3) Suitable **only** with NBR seals
 4) When using flame-resistant hydraulic fluids HFC, the following limitations are to be observed:
 – Max. operating pressure 210 bar
 – Max. hydraulic fluid temperature 60 °C
 – Expected service life 30...100 % as compared to HLP
 5) The cleanliness classes specified for the components must be adhered to in hydraulic systems. Effective filtration prevents faults and at the same time increases the service life of the components.
 For the selection of the filters see www.boschrexroth.com/filter
 6) Does not apply to types "G24 - 8"

electric			"G24"	"G24-8"
Minimum solenoid current		mA	≤ 100	≤ 100
Maximum solenoid current		mA	1600 ± 10 %	800 ± 5 %
Solenoid coil resistance	Cold value at 20 °C	Ω	5.5	20.6
	Max. hot value	Ω	8	33
Duty cycle		%	100	100

electrical, integrated electronics (OBE)

Supply voltage	Nominal voltage	VDC	24
	Lower limit value	VDC	21
	Upper limit value	VDC	35
Current consumption		A	≤ 1.5
Required fuse protection		A	2, time-lag
Inputs	Voltage	V	0 to 10
	Current	mA	4 to 20
Output	Actual current value	mV	1 mV \triangle 1 mA
Protection class of the valve according to EN 60529			IP 65 with mating connector mounted and locked

Caution!

With an ambient temperature of 70 °C and a duty cycle of 100 % with max. current, the coil of the 800 mA solenoid reaches temperatures of up to 170 °C. In case of contact with the coil, this may lead to burns.

Electrical connection (dimensions in mm)

DRE(M)

Connection at connector

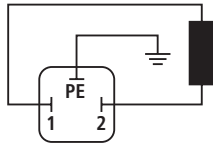

Connection at mating connector

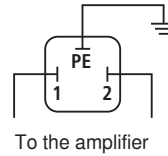

Mating connector (black) according to DIN EN 175301-803
Material no. **R901017011**
(separate order)

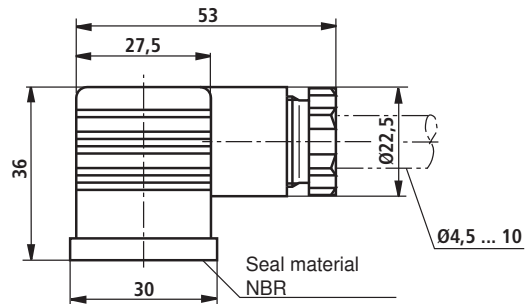
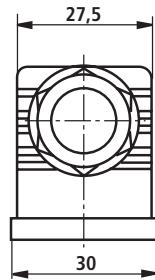

DRE(M)E

Device connector allocation	Contact	Allocation interface "A1"	Allocation interface "F1"
Supply voltage	A	24 VDC ($u(t) = 21 \text{ V to } 35 \text{ V}$); $I_{\text{max}} \leq 1.5 \text{ A}$	
	B	0 V	
Reference potential actual value	C	Reference contact F; 0 V	Reference contact F; 0 V
Differential amplifier input	D	0 to 10 V; $R_E = 100 \text{ k}\Omega$	4 to 20 mA; $R_E = 100 \text{ k}\Omega$
	E	Reference potential command value	
Measuring output (actual value)	F	0 to 1.6 V actual value ($1 \text{ mV} \triangleq 1 \text{ mA}$) Load resistance $> 10 \text{ k}\Omega$	
	PE	Connected to solenoid and valve housing	

Mating connectors according to DIN EN 175201-804, solder contacts for line cross-section 0.5 to 1.5 mm²

Plastic version,
material no. **R900021267**,
(separate order)

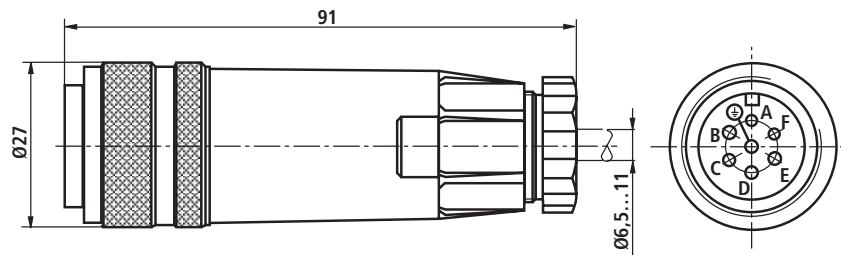

Metal version,
material no. **R900223890**
(separate order)

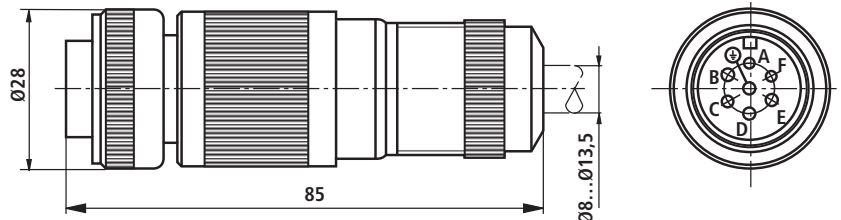

Electrical connection

Connection cable for DRE(M)E

- Recommendation 6-wire, 0.75 or 1 mm² plus protective earthing conductor and screening
- Only connect the screening to PE on the supply side
- Max. admissible length 100 m

The minimum supply voltage at the mains adapter depends on the length of the supply line (see diagram).

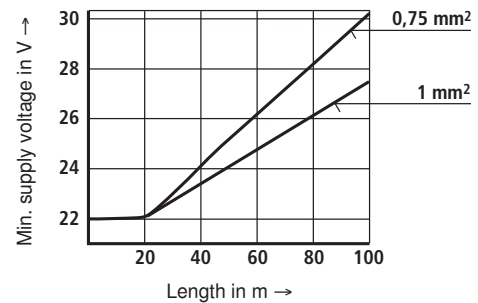

Integrated electronics (OBE) with type DRE(M)E

Function

The electronics are supplied with voltage via ports A and B. The command value is applied to the differential amplifier ports D and E.

Via the characteristic curve generator, the command value solenoid current characteristic curve is adjusted to the valve so that non-linearities in the hydraulic system are compensated and thus, a linear command value pressure characteristic curve is created.

The current controller controls the solenoid current independent of the solenoid coil resistance.

The power section of the electronics for controlling the proportional solenoid is a chopper amplifier with a cycle frequency of approx. 180 Hz to 400 Hz. The output signal is pulse-width modulated (PWM).

For checking the solenoid current, a voltage can be measured between pin F(+) and pin C(-) that is proportional to the solenoid current. **1 mV** corresponds to **1 mA** solenoid current.

Block diagram

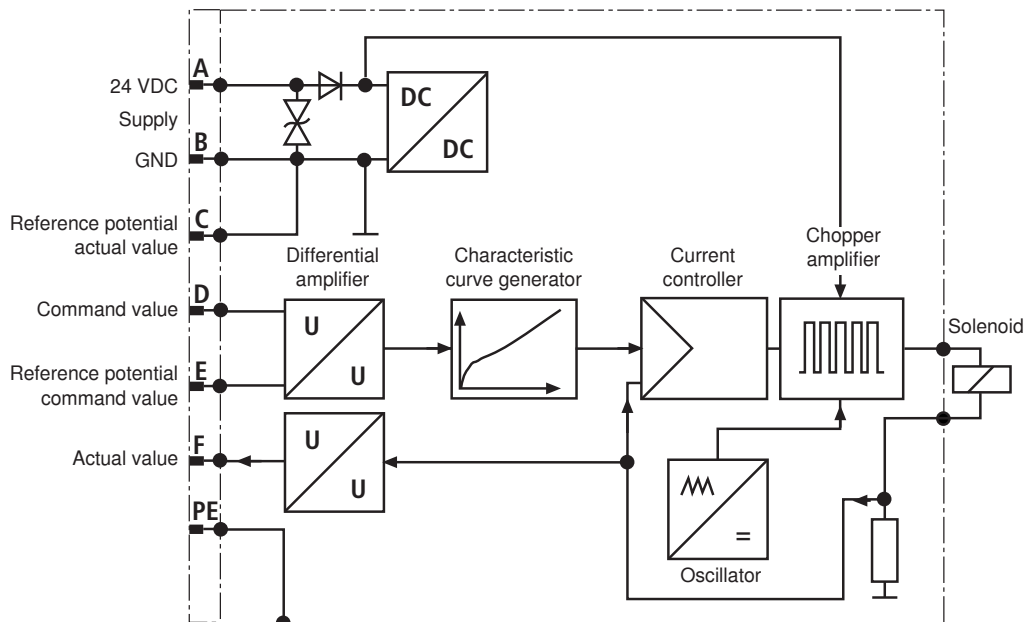

Characteristic curves (measured with HLP46, $\vartheta_{oil} = 40 \text{ }^\circ\text{C} \pm 5 \text{ }^\circ\text{C}$)

Pressure in port A depending on the command value (flow = 0.8 l/min)

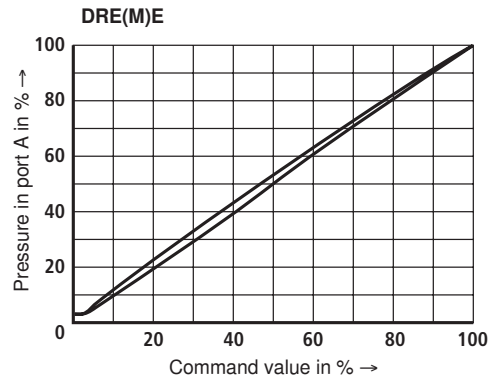
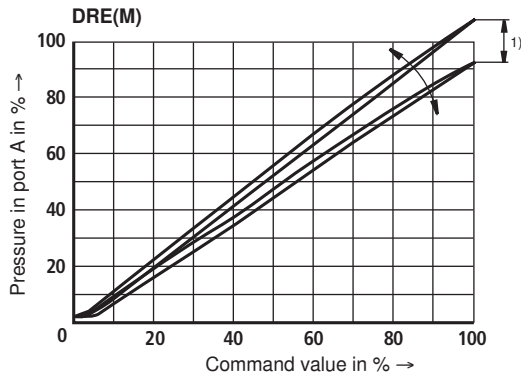

¹⁾ With valve DRE(M), the manufacturing tolerance at the **external amplifier** (type and data sheet see page 2) can be changed using the command value attenuator potentiometer "Gw". With the digital amplifier, the setting is made using the "Limit" parameter.

In this connection, the control current according to the technical data must not be exceeded.

In order to be able to adjust several valves to the same characteristic curve, the pressure must - with a command value of 100 % - at no valve not exceed the maximum setting pressure of the relevant pressure rating.

Pressure in channel A dependent on the flow q_v (characteristic curve with constant Δp)

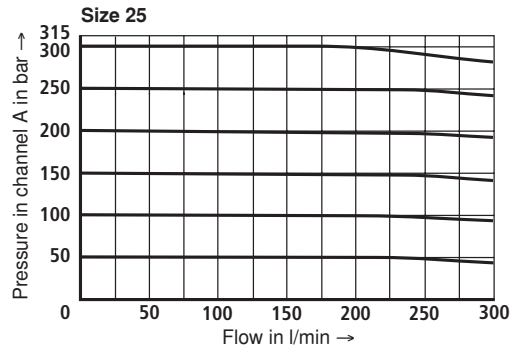
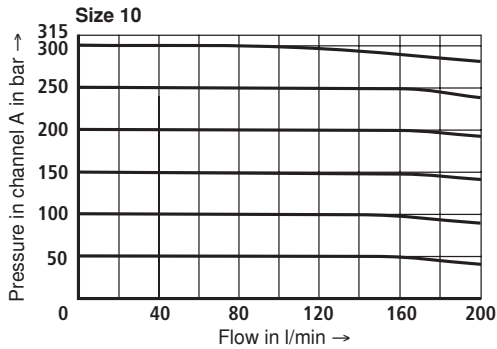

Pressure differential via the check valve from A to B

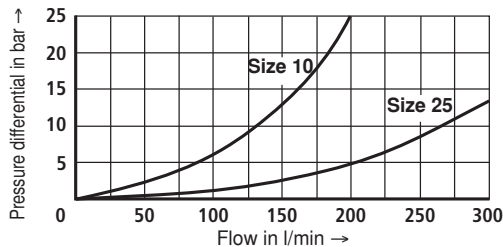

Pressure differential from B to A

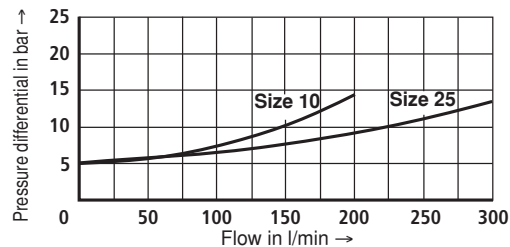

Characteristic curves (measured with HLP46, $\vartheta_{oil} = 40 \text{ }^\circ\text{C} \pm 5 \text{ }^\circ\text{C}$ and amplifier VT VSPA1-11-1X, 1600 mA coil...)

Pressure in channel A depending on the command value
Pressure rating 50 bar

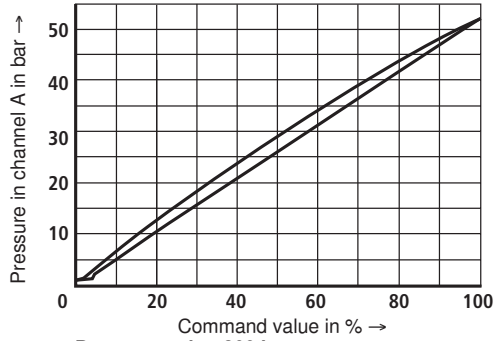

Pressure rating 100 bar

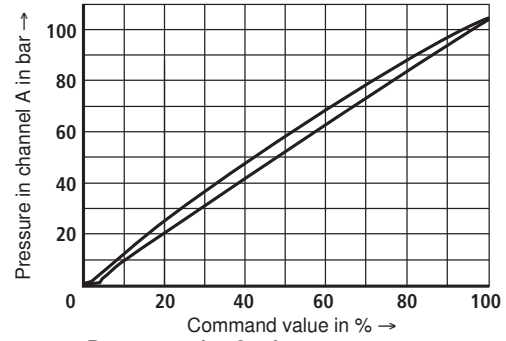

Pressure rating 200 bar

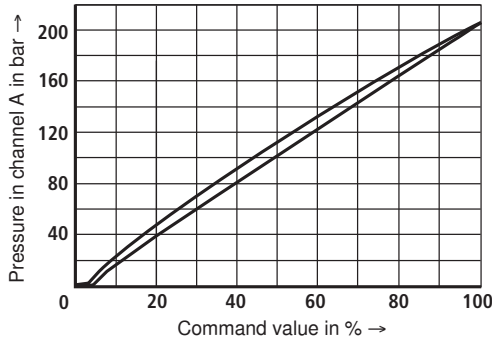

Pressure rating 315 bar

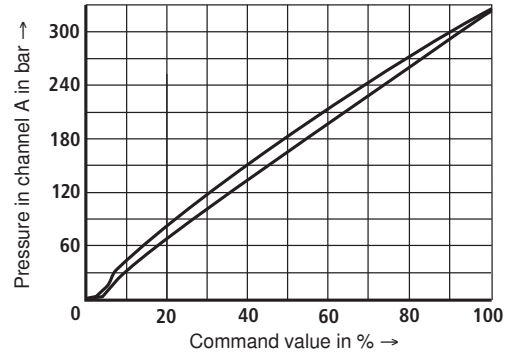

Pressure rating 200 bar (with VT-SSPA1)

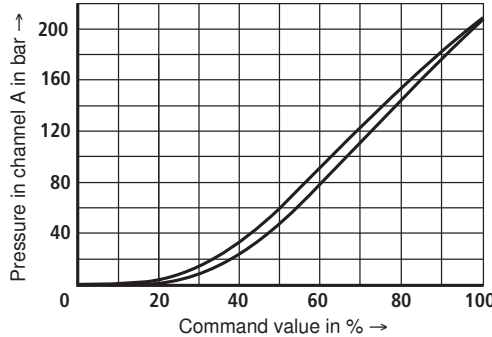

Comparison series 5X-6X / pressure rating 100 bar
(with amplifier VT-VSPA1-1-1X with 800 mA coil)

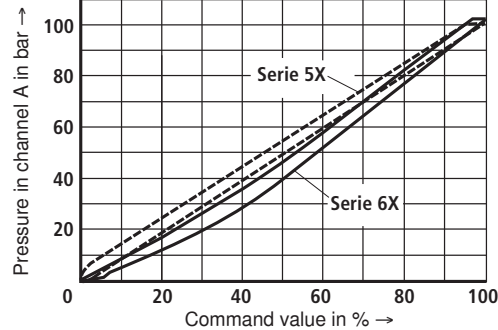

Comparison series 5X-6X / pressure rating 315 bar
(with amplifier VT-VSPA1-1-1X with 800 mA coil)

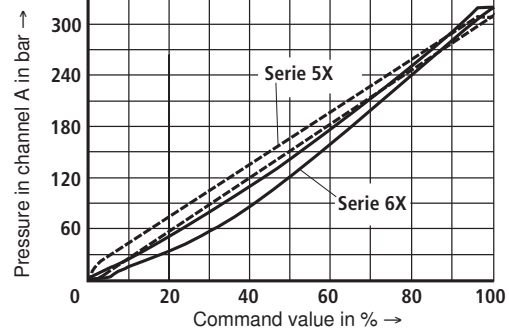

Unit dimensions type DRE(M) (dimensions in mm)

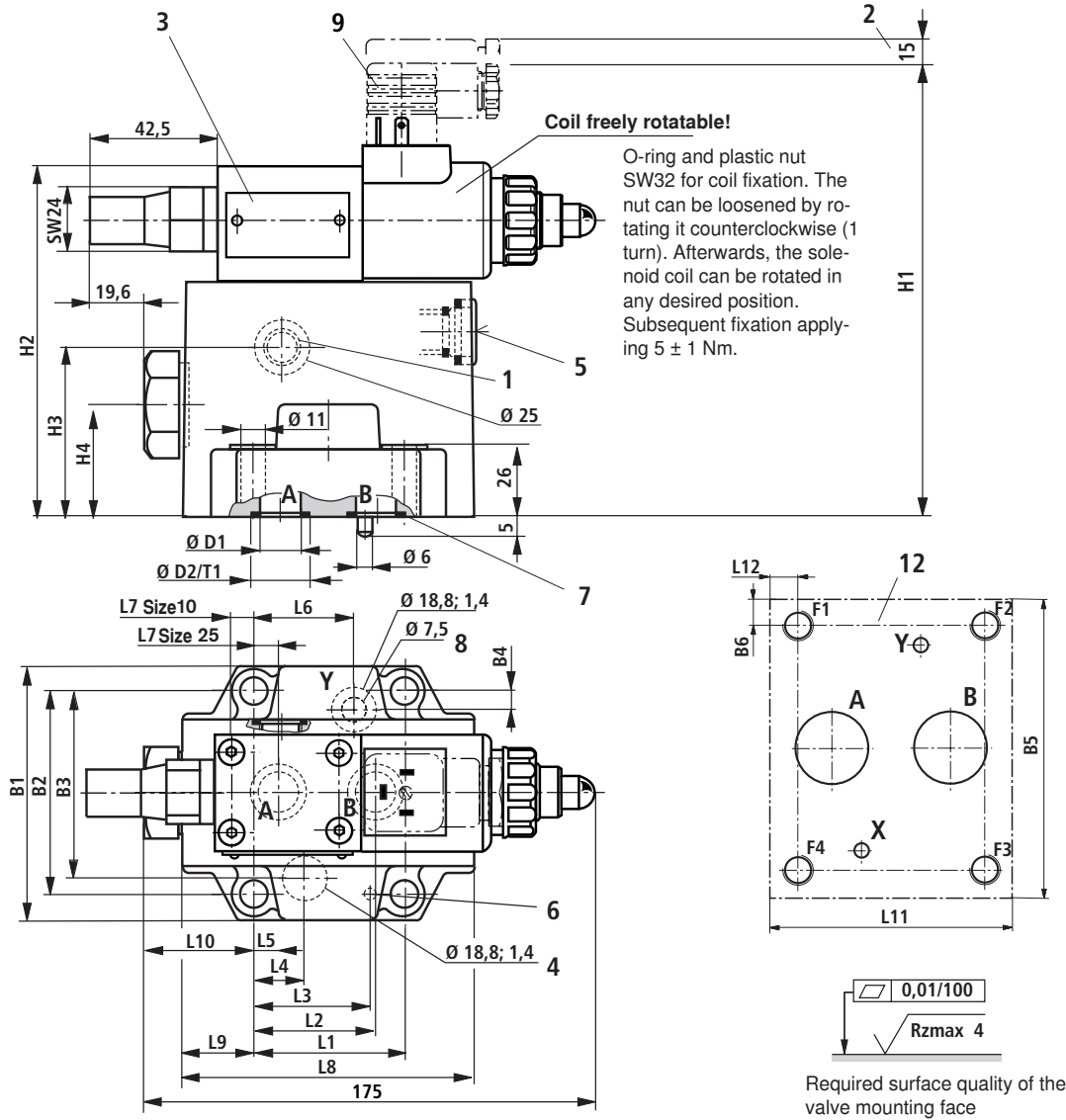

Size	B1	B2	B3	B4	ØD1	ØD2 ^{H11}	H1	H2	H3	H4	
10	85	66.7	58.8	7.9	15	21.8	171	123	58	36	
25	102	79.4	73	6.4	25	34.8	185	137	64	44	
Size	L1	L2	L3	L4	L5	L6	L7	L8	L9	L10	T1
10	42.9	35.8	31.8	21.5	7.2	21.5	5	116	44.5	59.5	2.0
25	60.3	49.2	44.5	20.6	11.1	39.7	12.2	116	27.3	42	2.9
Size	B5	B6	L11	L12							
10	84	8.65	61	9.05							
25	97	8.8	78	8.85							

Unit dimensions type DRE(M)E (dimensions in mm)

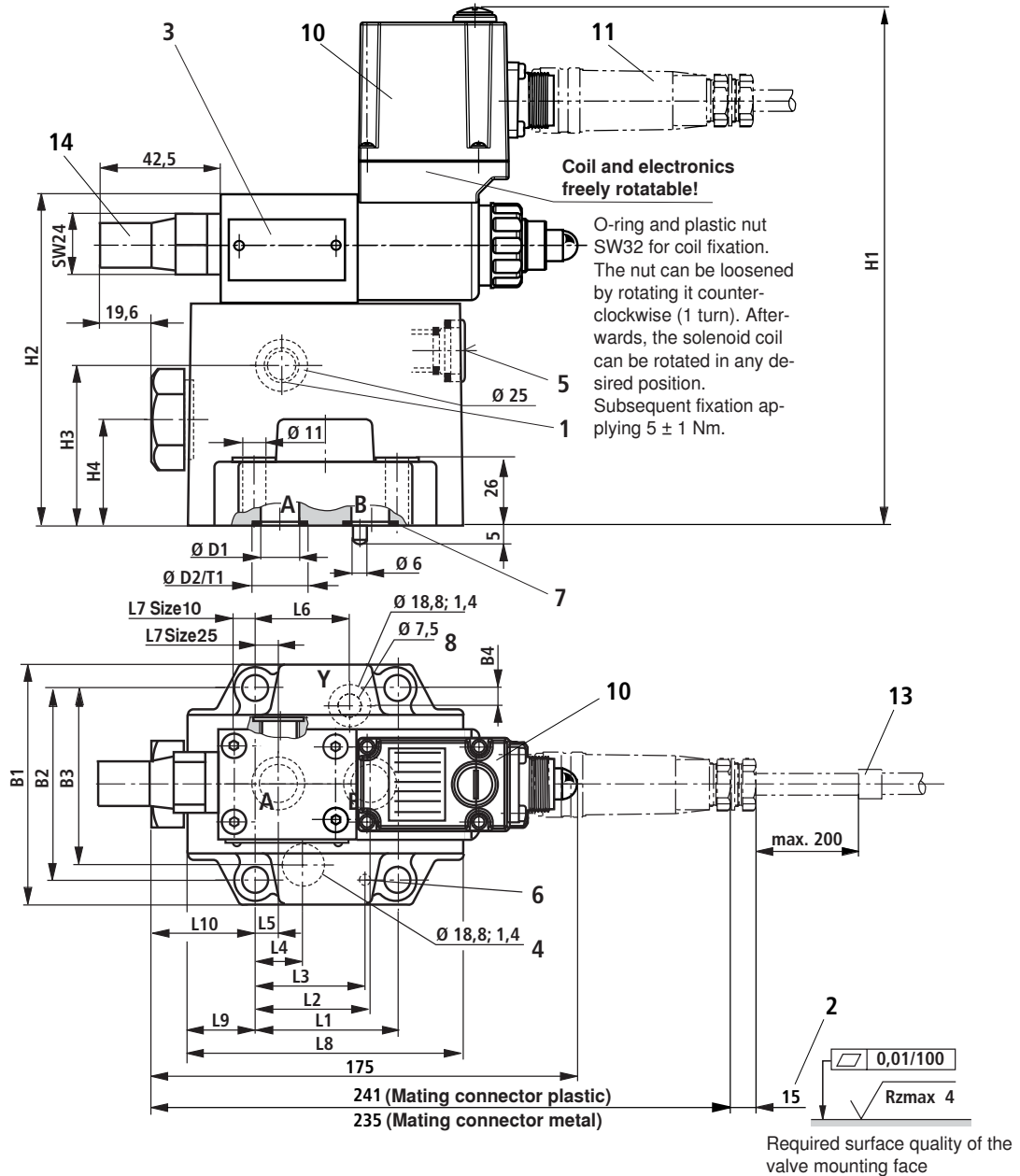

Size	B1	B2	B3	B4	ØD1	ØD2 ^{H11}	H1	H2	H3	H4	
10	85	66.7	58.8	7.9	15	21.8	192	123	58	36	
25	102	79.4	73	6.4	25	34.8	206	137	64	44	
Size	L1	L2	L3	L4	L5	L6	L7	L8	L9	L10	T1
10	42.9	35.8	31.8	21.5	7.2	21.5	5	116	44.5	59.5	2.0
25	60.3	49.2	44.5	20.6	11.1	39.7	12.2	116	27.3	42	2.9

Unit dimensions (continued)

- 1 Upon delivery, this port (G1/4) is closed. After removal of the blanking plug, an external and separate pilot oil return at zero pressure to the tank is, however, also possible here.
- 2 Space required for removing the mating connector
- 3 Name plate
- 4 Blind counterbore
- 5 Check valve, optional
- 6 Locating pin
- 7 Identical seal rings for ports A and B
Identical seal rings for port Y and blind counterbore (item 4)
- 8 Pilot oil return always external and separately at zero pressure to the tank, or optionally at item 1
- 9 Mating connector according to DIN EN 175301-803
- 10 Integrated electronics (OBE), type DRE(M)E with connector "K31"
- 11 Mating connector according to DIN EN 175201-804
- 12 Processed installation surface, porting pattern according to ISO 5781-06-07-0-00 (size 10)
ISO 5781-08-10-0-00 (size 25)
- 13 Cable fastening
- 14 Maximum pressure limitation with version DREM and DREME

Subplates according to data sheet RE 45062 and valve mounting screws must be ordered separately.

Subplates:

Size 10: G 460/01 (G 3/8)
G 461/01 (G 1/2)

Size 25: G 412/01 (G 3/4)
G 413/01 (G 1)

Valve mounting screws:

4 hexagon socket head cap screws

ISO 4762-M10x45-10.9-flZn-240h-L

(friction coefficient $\mu_{\text{total}} = 0.09$ to 0.14 ,

Tightening torque $M_A = 59 \text{ Nm} \pm 10 \%$

or

4 hexagon socket head cap screws ISO 4762-M10x45-10.9

(friction coefficient $\mu_{\text{total}} = 0.12$ to 0.17)

Tightening torque $M_A = 75 \text{ Nm} \pm 10 \%$

Notes

© This document, as well as the data, specifications and other information set forth in it, are the exclusive property of Bosch Rexroth AG. It may not be reproduced or given to third parties without its consent. The data specified above only serve to describe the product. No statements concerning a certain condition or suitability for a certain application can be derived from our information. The information given does not release the user from the obligation of own judgment and verification. It must be remembered that our products are subject to a natural process of wear and aging.