

## RE 26 572/11.02

Replaces: 12.95

### Pressure reducing valve, pilot operated, Type ZDRK 6 VP

Nominal size 6

Series 1X

Maximum operating pressure 210 bar

Maximum flow 40 L/min

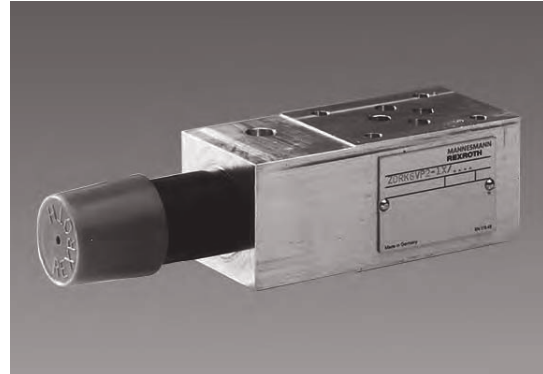

H/A 4085/94

Type ZDRK 6 VP5-1X/...

### Overview of contents

#### Contents

Features  
Ordering details, symbol  
Function, section  
Technical data  
Characteristic curves  
Unit dimensions

### Features

- |             |   |
|-------------|---|
| <b>Page</b> | – Sandwich plate valve  |
| 1           | – Porting pattern to DIN 24 340 Form A, ISO 4401 and CETOP–RP 121 H (locating pin 3 x 8 DIN EN ISO 8752 Material No. R900005694 – separate order) |
| 2           | – 3 pressure stages   |
| 2           | – Pressure reduction in port P1   |
| 3           | – Pressure gauge connection port  |
| 4           | – Adjustment element: Sleeve with hexagon and protective cap  |

### Ordering details, symbol (① = component side, ② = subplate side)

Symbol	Pressure relief	Secondary pressure in bar	Setting element	Material No.	Type description
	In channel P1	50		R900564543	ZDRK 6 VP5-1X/50YMV
		100		R900564544	ZDRK 6 VP5-1X/100YMV
		210		R900564545	ZDRK 6 VP5-1X/210YMV



© 2002  
by Bosch Rexroth AG, Industrial Hydraulics, D-97813 Lohr am Main

All rights reserved. No part of this document may be reproduced or stored, processed, duplicated or circulated using electronic systems, in any form or by means, without the prior written authorisation of Bosch Rexroth AG. In the event of contravention of the above provisions, the contravening party is obliged to pay compensation.

This document was prepared with the greatest of care, and all statements have been examined for correctness. This document is subject to alterations for reason of the continuing further developments of products. No liability can be accepted for any incorrect or incomplete statements.

## Function, section

Pressure reducing valves type ZDRK 6 VP are 3-way direct operated pressure reducing valves of sandwich plate design with a pressure relief function on the secondary side. It is used to reduce a system pressure.

The pressure reducing valve basically consists of the cartridge (1) and housing (2). The secondary pressure is set by the pressure adjustment element (4).

At rest the valves are open; pressure fluid can flow unhindered from port P2 to port P1. The pressure in port P1 is applied simultaneously to the main spool (6) and via the bore (5) to the spring loaded internal area of the main spool (6). At the same time the pressure is also applied onto the pilot poppet (8) via orifice (9). If the pressure in port P1 rises above the value set at the compression spring (7) then the pilot poppet (8) opens. Pressure fluid flows from the spring loaded

internal area of the main spool (6) via the orifice (9) and the pilot poppet (8) into the spring chamber (10). The main spool (6) moves into the control position and maintains the value in port P1, which was set at the spring (7).

If the pressure in port P1 continues to rise due to external forces at the actuator, then the main spool (6) moves still further against the compression spring (7).

Thereby port P1 is connected to the tank (port T) via the control land at the main spool and housing. Enough pressure fluid flows into the tank to ensure that the pressure does not continue to rise. The leakage oil return from the spring chamber (10) is via port T.

A pressure gauge port (3) makes it possible to monitor the secondary pressure at the valve.

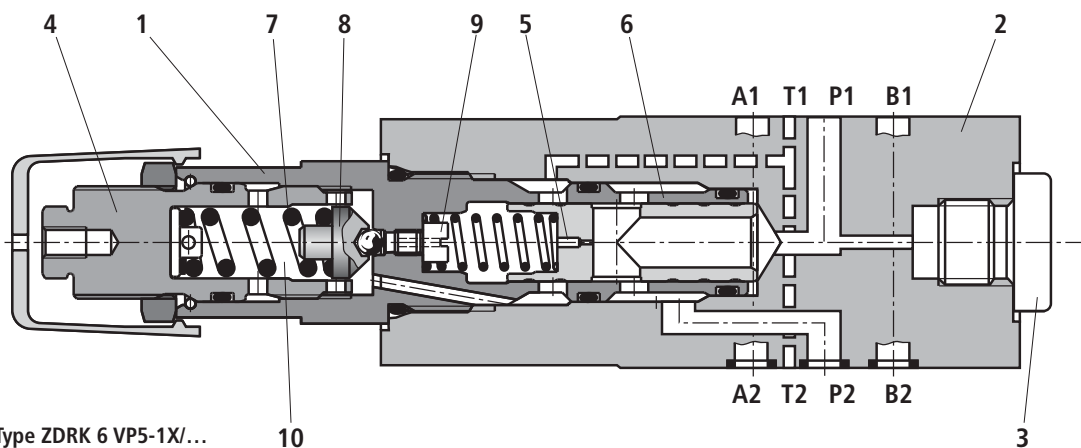

Type ZDRK 6 VP5-1X/...

**Technical data** (for applications outside these parameters, please consult us!)

### General

Installation		Optional
Ambient temperature range	°C	-20 to +80
Weight	kg	Approx. 1.8

### Hydraulic

Pressure fluid		Mineral oil (HL, HLP) to DIN 51 524; Fast bio-degradable pressure fluids to VDMA 24 568 (also see RE 90 221); HETG (rape seed oil); HEPG (polyglycols); HEES (synthetic ester); Other pressure fluids on request
Pressure fluid temperature range	°C	-20 ... +80
Viscosity range	mm <sup>2</sup> /s	10 to 800
Cleanliness class to ISO code		Maximum permissible degree of contamination of the pressure fluid is to ISO 4406 (C) class 20/18/15 <sup>1)</sup>
Maximum operating pressure (input)	bar	210
Maximum secondary pressure (output)	bar	50; 100; 210
Maximum back pressure (port T)	bar	160
Maximum flow	L/min	40

<sup>1)</sup> The cleanliness class stated for the components must be adhered to in hydraulic systems. Effective filtration prevents faults from occurring and at the same time increases the component service life.  
For the selection of filters see catalogue sheets RE 50 070, RE 50 076 and RE 50 081.

## Characteristic curves (measured with HLP46, $\vartheta_{oil} = 40\text{ °C} \pm 5\text{ °C}$ )

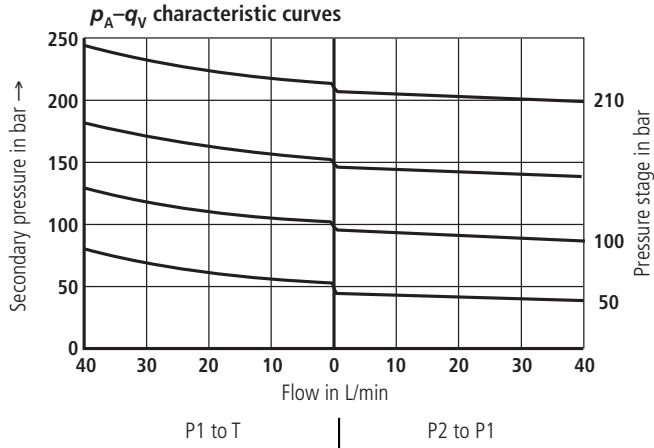

### ⚠ Attention!

The curve characteristics remain, with a lower set pressure, the same in relation to the pressure rating.

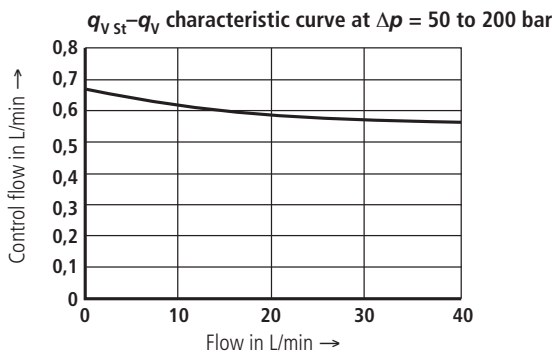
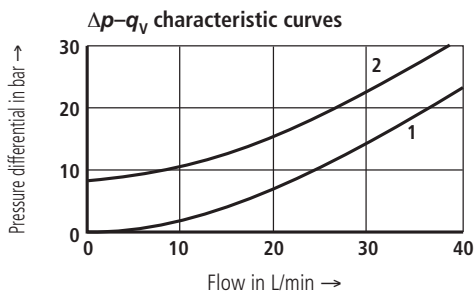

The characteristic curves for the pressure relief function are valid for output pressure = zero over the complete flow range!

## Unit dimensions

(Dimensions in mm)

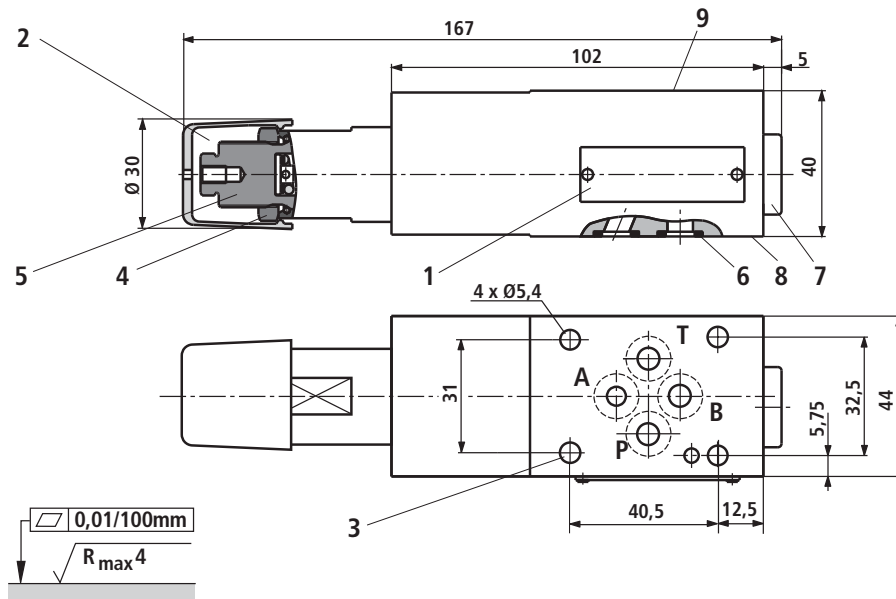

$0,01/100\text{mm}$   
 $R_{\text{max}} 4$

Required surface finish of the mating piece

- 1 Name plate
- 2 Adjustment element (sleeve with hexagon and protective cap)
- 3 Valve fixing holes
- 4 Lock nut 24A/F
- 5 Hexagon 10A/F
- 6 Identical seal rings for ports A2, B2, P2, T2
- 7 Pressure gauge port: G 1/4; 12 deep, internal hexagon 6A/F  
Pipe thread (G..) to ISO 228/1

- 8 Porting pattern to ISO 4401 and CETOP-RP 121 H, **with** locating pin hole,  $\varnothing 3 \times 5$  mm deep for a  $\varnothing 3 \times 8$  mm DIN EN ISO 8752 locating pin, Material No. R900005694 (separate order)
- 9 Porting pattern to ISO 4401 and CETOP-RP 121 H, **with** locating pin hole,  $\varnothing 4 \times 4$  mm deep

### Valve fixing screws

M5 DIN 912-10.9,  
Tightening torque  $M_A = 8.9$  Nm,  
must be ordered separately

The data specified above only serves to describe the product. No statements concerning a certain condition or suitability for a certain application can be derived from our information. It must be remembered that our products are subject to a natural process of wear and ageing.