

## Inline filter with filter element according to DIN 24550

**RE 51422/07.11** 1/18  
Replaces: 12.10

**Type 350LEN0040 to 1000; 350LE0130, 0150**

Size according to **DIN 24550**: 0040 to 1000  
Additional sizes: 0130, 0150  
Nominal pressure 350 bar [5079 psi]  
Port up to G 2; SAE 2"; SAE 24  
Operating temperature -10 °C to 100 °C [14 °F to 212 °F]



350LEN\_d

### Table of contents

Content	Page
Features	1
Ordering code	2
Standard types	3
Ordering code:	
Electronic switching element for maintenance indicator	4
Mating connectors according to IEC 60947-5-2	4
Symbols	5
Function, section	6
Technical data	7, 8
Characteristic curves	9...12
Unit dimensions	13
Maintenance indicator	14
Spare parts	15
Installation, commissioning, maintenance	16
Quality and standardization	17

### Features

- Inline filters are used in hydraulic systems for separating solid materials from the hydraulic fluids and lubricating oils. They are intended for installation into pipelines.
- They distinguish themselves by the following:
- Special highly efficient filter media
  - Adsorption of very fine particles across a broad pressure differential range
  - High dirt holding capacity thanks to large specific filter area
  - Good chemical resistance of the filter elements
  - High collapse resistance of the filter elements (e.g. in case of cold start)
  - Filter ratings of 3 µm to 100 µm
  - By default equipped with mechanical optical maintenance indicator with memory function
  - Flow-optimized version due to 3D computer-supported design

## Ordering code

of the filter

350 LE N — 00 — V5,0 —

### Pressure

350 bar  
[5079 psi] = 350

### Inline filter

Simple = LE

### Filter element

According to DIN 24550 = N

### Size

LEN... = 0040 0063 0100 0160

0250 0400 0630 1000

LE... = 0130 0150

### Filter rating in µm

#### nominal

Stainless steel wire mesh, cleanable  
G10, G25, G40, G100 = G...

#### absolute (ISO 16889)

Micro glass, not cleanable  
H3XL, H6XL, H10XL, H20XL = H...XL

### Pressure differential

Max. admissible pressure differential of the filter element

30 bar [435 psi], with bypass valve 7 bar [102 psi] = A

330 bar [4786 psi], without bypass valve = B

### Element version

Standard adhesive T = 100 °C [212 °F] = 0...

Standard material tin-plated = ...0

### Maintenance indicator

Maintenance indicator, optical = V5,0

specify switching pressure 5.0 bar [72.5 psi]

Port

	Frame size	0040	0063-0100	0130-0150	0160-0400	0630-1000	
	Port						
R2 =	G1/2	•	x				Pipe-thread according to ISO 228
R3 =	G3/4	x	x				
R4 =	G1	x	•	x			
R5 =	G1 1/4			•	x		
R6 =	G1 1/2			x	•		
R8 =	G2					•	
S6 =	SAE 1 1/2"				x		SAE flange 6000 psi
S8 =	SAE 2"					x	
U3 =	SAE 10	x					Pipe-thread according to SAE J1926
U4 =	SAE 12		x				
U5 =	SAE 20			x			
U6 =	SAE 24				x		

• = Standard port

x = Additional connection possibility

Seal

M = NBR seal

V = FKM seal

### Order example:

350LEN0100-H10XLA00-V5,0-M-R4

Further versions (filter materials, connections, ...) are available at request.

of the filter element

2. — — 0 —

### Filter element

Design = 2.

### Size

LEN... = 0040 0063 0100 0160 0250 0400 0630 1000

LE... = 0130 0150

### Filter rating in µm

#### nominal

Stainless steel wire mesh, cleanable  
G10, G25, G40, G100 = G...

#### absolute (ISO 16889)

Micro glass, not cleanable  
H3XL, H6XL, H10XL, H20XL = H...XL

Seal

M = NBR seal

V = FKM seal

### Bypass valve

0 = at filter element always 0

### Pressure differential

Max. admissible pressure differential of the filter element

A00 = 30 bar [435 psi]

B00 = 330 bar [4786 psi]

### Order example:

2.0100 H10XL-A00-0-M

## Standard types

350LE(N) standard types, NBR seal, flow information for  $v = 30 \text{ mm}^2/\text{s}$  [150 SUS]

### Inline filter with bypass, filtration rating 3 $\mu\text{m}$

Type	Flow in l/min [US gpm] with $\Delta p = 1 \text{ bar}$ [14.5 psi] <sup>1)</sup>	Material no. Filter				Material no. Replacement element
		..R2	..R4	..U3	..U4	
350LEN0040-H3XLA00-V5,0-M-..	26 [6.87]	..R2	R928033024	..U3	R928033216	R928006645
350LEN0063-H3XLA00-V5,0-M-..	36 [9.51]	..R4	R928033025	..U4	R928033217	R928006699
350LEN0100-H3XLA00-V5,0-M-..	46 [12.15]	..R4	R928033026	..U4	R928033218	R928006753
350LE0130-H3XLA00-V5,0-M-..	74 [19.55]	..R5	R928033027	..U5	R928033219	R928022274
350LE0150-H3XLA00-V5,0-M-..	83 [21.93]	..R5	R928033028	..U5	R928033220	R928022283
350LEN0160-H3XLA00-V5,0-M-..	125 [33.02]	..R6	R928033029	..U6	R928033221	R928006807
350LEN0250-H3XLA00-V5,0-M-..	200 [52.83]	..R6	R928033030	..U6	R928033222	R928006861
350LEN0400-H3XLA00-V5,0-M-..	253 [66.84]	..R6	R928033031	..U6	R928033223	R928006915
350LEN0630-H3XLA00-V5,0-M-..	340 [89.82]	..R8	R928034432	..S8	R928034448	R928006969
350LEN1000-H3XLA00-V5,0-M-..	470 [124.16]	..R8	R928034433	..S8	R928034449	R928007023

### Inline filter with bypass, filtration rating 6 $\mu\text{m}$

Type	Flow in l/min [US gpm] with $\Delta p = 1 \text{ bar}$ [14.5 psi] <sup>1)</sup>	Material no. Filter				Material no. Replacement element
		..R2	..R4	..U3	..U4	
350LEN0040-H6XLA00-V5,0-M-..	33 [8.72]	..R2	R928033280	..U3	R928033472	R928006646
350LEN0063-H6XLA00-V5,0-M-..	55 [14.53]	..R4	R928033281	..U4	R928033473	R928006700
350LEN0100-H6XLA00-V5,0-M-..	69 [18.23]	..R4	R928033282	..U4	R928033474	R928006754
350LE0130-H6XLA00-V5,0-M-..	114 [30.12]	..R5	R928033283	..U5	R928033475	R928022275
350LE0150-H6XLA00-V5,0-M-..	130 [34.34]	..R5	R928033284	..U5	R928033476	R928022284
350LEN0160-H6XLA00-V5,0-M-..	168 [44.38]	..R6	R928033285	..U6	R928033477	R928006808
350LEN0250-H6XLA00-V5,0-M-..	232 [61.29]	..R6	R928033286	..U6	R928033478	R928006862
350LEN0400-H6XLA00-V5,0-M-..	281 [74.23]	..R6	R928025783	..U6	R928033479	R928006916
350LEN0630-H6XLA00-V5,0-M-..	405 [106.99]	..R8	R928034464	..S8	R928034480	R928006970
350LEN1000-H6XLA00-V5,0-M-..	492 [129.97]	..R8	R928034465	..S8	R928034481	R928007024

### Inline filter with bypass, filtration rating 10 $\mu\text{m}$

Type	Flow in l/min [US gpm] with $\Delta p = 1 \text{ bar}$ [14.5 psi] <sup>1)</sup>	Material no. Filter				Material no. Replacement element
		..R2	..R4	..U3	..U4	
350LEN0040-H10XLA00-V5,0-M-..	37 [9.77]	..R2	R928033536	..U3	R928033728	R928006647
350LEN0063-H10XLA00-V5,0-M-..	70 [18.49]	..R4	R928033537	..U4	R928033729	R928006701
350LEN0100-H10XLA00-V5,0-M-..	78 [20.61]	..R4	R928033538	..U4	R928033730	R928006755
350LE0130-H10XLA00-V5,0-M-..	138 [36.46]	..R5	R928025653	..U5	R928033731	R928022276
350LE0150-H10XLA00-V5,0-M-..	162 [42.80]	..R5	R928028868	..U5	R928033732	R928022285
350LEN0160-H10XLA00-V5,0-M-..	198 [52.31]	..R6	R928033541	..U6	R928033733	R928006809
350LEN0250-H10XLA00-V5,0-M-..	252 [66.57]	..R6	R928033542	..U6	R928033734	R928006863
350LEN0400-H10XLA00-V5,0-M-..	301 [79.52]	..R6	R928033543	..U6	R928033735	R928006917
350LEN0630-H10XLA00-V5,0-M-..	450 [118.88]	..R8	R928034496	..S8	R928034512	R928006971
350LEN1000-H10XLA00-V5,0-M-..	521 [137.63]	..R8	R928034497	..S8	R928034513	R928007025

<sup>1)</sup> Measured pressure differential across filter and measuring equipment according to ISO 3968. The measured pressure differential at the maintenance indicator is lower.

## Ordering code: Electronic switching element for maintenance indicator

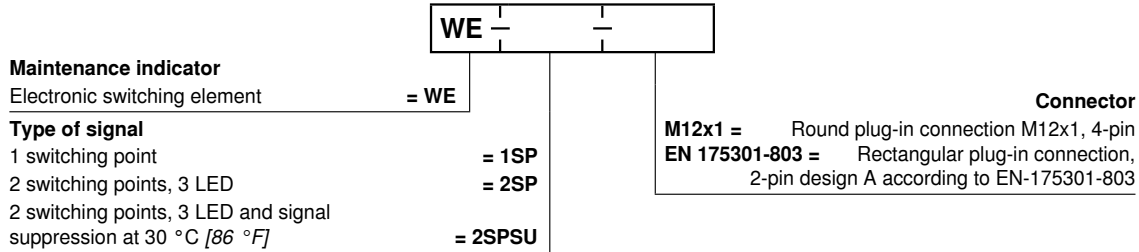

### Material numbers of the electronic switching elements

Material no.	Type	Signal	Switching points	Connector	LED
R928028409	WE-1SP-M12x1	Changeover	1	M12x1	No
R928028410	WE-2SP-M12x1	Normally open (at 75 %) / normally closed contact (at 100 %)	2		3 pieces
R928028411	WE-2SPSU-M12x1				
R928036318	WE-1SP-EN175301-803	Normally closed contact	1	EN 175301-803	No

More information on maintenance indicators is available in the data sheet 51450

**Order example:** Inline filter with mechanical optical maintenance indicator for  $p_{nom.} = 350 \text{ bar}$  [5079 psi] with bypass valve, size 0100, with filter element 10  $\mu\text{m}$  and electronic switching element M12x1 with 1 switching point for hydraulic fluid mineral oil HLP according to DIN 51524.

**Filter:** 350LEN0100-H10XLA00-V5,0-M-R4 **Material no. R928033538**  
**Maintenance indicator:** WE-1SP-M12x1 **Material no. R928028409**

## Mating connectors according to IEC 60947-5-2 (dimensions in mm [inch])

for electronic switching element with round plug-in connection M12 x 1

Mating connector for K24 4-pin, M12 x 1 with screw connection, cable gland Pg9.

Material no. R900031155

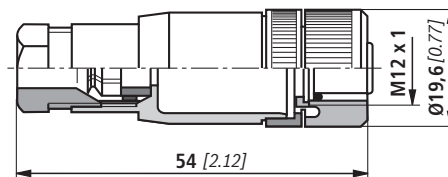

Mating connector for K24-3m 4-pin, M12 x 1 with potted-in PVC cable, 3 m long.

Line cross-section: 4 x 0.34 mm<sup>2</sup>

Core marking:

1	Brown
2	White
3	Blue
4	Black

Material no. R900064381

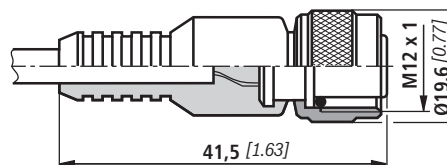

For more round plug-in connections, see data sheet 08006.

## Symbols

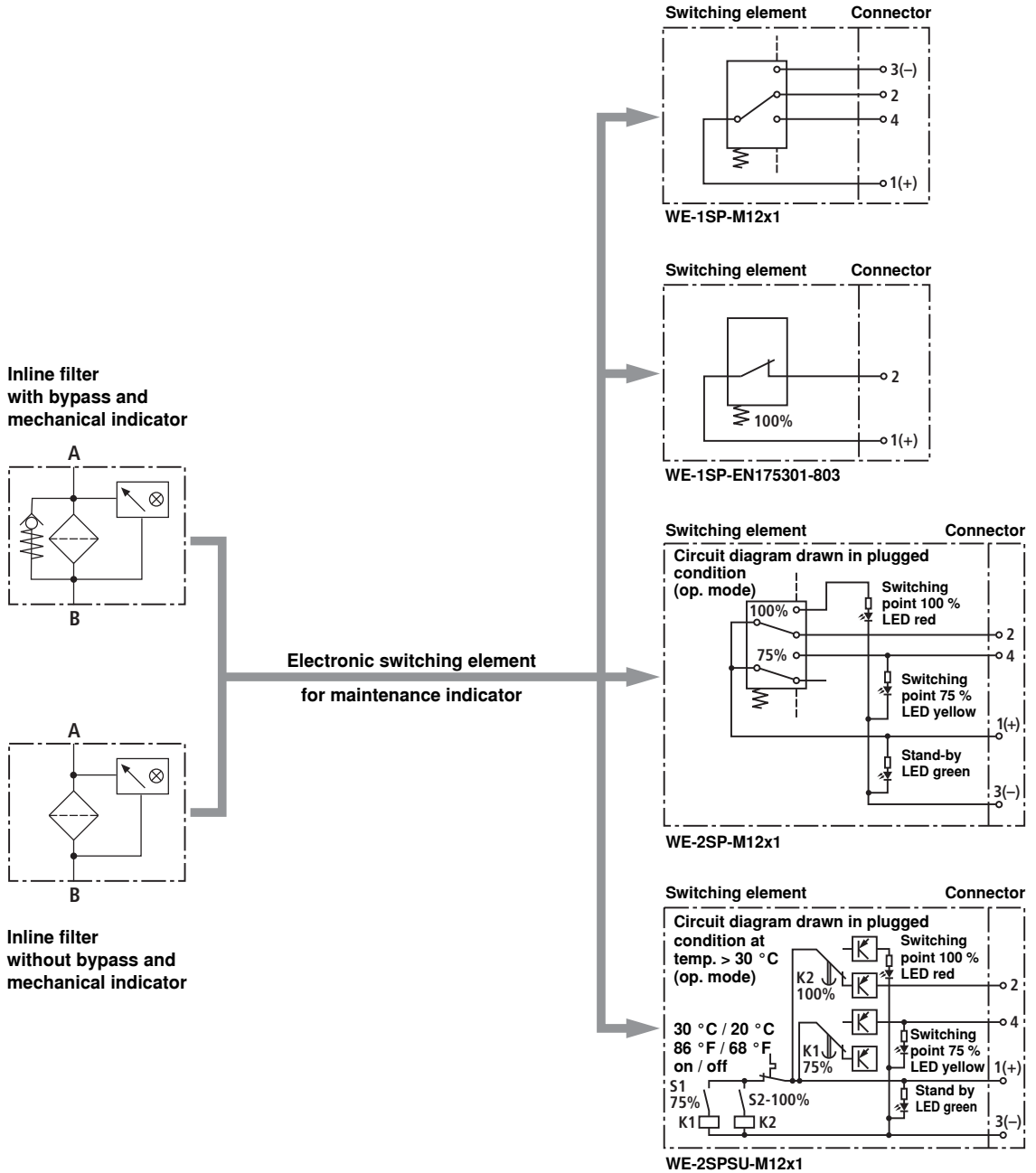

## Function, section

The 350LE(N) Inline filters are suitable for direct installation into pressure lines. They are mostly installed upstream open-loop or closed-loop control units to be protected.

They basically consist of filter head (1), a screwable filter bowl (2), filter element (3) as well as mechanical optical maintenance indicator (4). In case of filters with low-pressure-differential-stable filter elements (= code letter pressure differential A), there is also an assembled bypass valve (5).

Via port I, the hydraulic fluid reaches the filter element (3) where it is cleaned. The dirt particles filtered out settle in the filter bowl (2) and in the filter element (3). Via port 0, the filtered hydraulic fluid enters the hydraulic circuit.

The filter housing and all connection elements are designed so that pressure peaks - as they may e.g. occur in case of the abrupt opening of large control valves due to the accelerated fluid weight - can be securely absorbed. As of size 0160, the standard equipment comprises an oil drain plug (7). With size 1000, the filter bowl has a two-part design.

Basically, the filter is equipped with mechanical optical maintenance indicator (4). The electronic maintenance indicator is connected via the electronic switching element with 1 or 2 switching points (6), which has to be ordered separately. The electronic switching element is attached to the mechanical optical maintenance indicator and held by means of a locking ring.

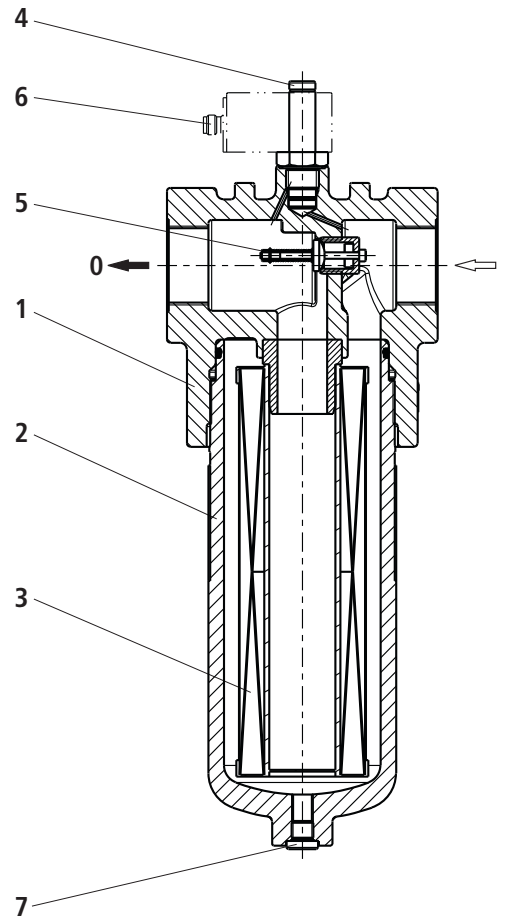

## Technical Data (For applications outside these parameters, please consult us!)

### general

Installation position	Vertical					
Ambient temperature range	°C [°F]	-30 to +100 [-22 to +212]				
Weight	Size	<b>0040</b>	<b>0063</b>	<b>0100</b>	<b>0130</b>	<b>0150</b>
	kg [lbs]	4.4 [9.73]	5.0 [11.1]	5.9 [13]	10.5 [23.21]	11.2 [24.76]
Weight	Size	<b>0160</b>	<b>0250</b>	<b>0400</b>	<b>0630</b>	<b>1000</b>
	kg [lbs]	17.2 [30.02]	19.5 [43.11]	23.0 [50.84]	45.0 [99.47]	93.0 [205.58]
Material	Filter head	GGG				
	Filter bowl	Steel				
	Optical maintenance indicator	Brass				
	Electronic switching element	Plastic PA6				

### hydraulic

Maximum operating pressure	bar [psi]	350 [5079]
Plage de température du fluide hydraulique	°C [°F]	-10 to +100 [+14 to +212] (shortly -30 [-22])
Fatigue strength according to ISO 10771	Load cycles	> 10 <sup>6</sup> with max. operating pressure
Cracking pressure of the bypass valve	bar [psi]	7 ± 0.5 [100 ± 7]
Type of pressure measurement of the maintenance indicator		Pressure differential
Response pressure of the maintenance indicator	bar [psi]	5 ± 0.5 [72 ± 7]

### electrical (electronic switching element)

Electrical connection	Version	Round plug-in connection M12x1, 4-pin			Standard connection EN 175301-803
		1SP-M12x1	2SP-M12x1	2SP-M12x1	1SP-EN175301-803
Contact load, direct voltage	A <sub>max.</sub>	1			
Voltage range	V <sub>max.</sub>	150 (AC/DC)	10-30 (DC)	250 (AC) / 200 (DC)	
Max. switching power with resistive load	W	20			70
Switching type	75 % signal	-	Normally open contact		-
	100 % signal	Change-over	Normally closed contact		Normally closed contact
	2SPSU			Signal switching through at 30 °C [86 °F], Return switching at 20 °C [68 °F]	
Display via LEDs in the electronic switching element 2SP...		Stand-by (LED green); 75 % switching point (LED yellow) 100 % switching point (LED red)			
Protection class according to EN 60529		IP 67			IP 65
Ambient temperature range	°C [°F]	-25 to +85 [-13 to +185]			
For direct voltage above 24 V, spark extinguishing is to be provided for protecting the switching contacts.					
Weight	Electronic switching element: - with round plug-in connection M12x1	kg [lbs]	0.1 [0.22]		

## Technical Data (For applications outside these parameters, please consult us!)

### Filter element

Glass fiber paper H..XL		Single-use element on the basis of inorganic fiber	
		Filtration ratio according to ISO 16889 up to $\Delta p = 5 \text{ bar [72.5 psi]}$	Achievable oil cleanliness according to ISO 4406 [SAE-AS 4059]
	H20XL	$\beta_{20}(c) \geq 200$	19/16/12 – 22/17/14
	H10XL	$\beta_{10}(c) \geq 200$	17/14/10 – 21/16/13
	H6XL	$\beta_6(c) \geq 200$	15/12/10 – 19/14/11
	H3XL	$\beta_3(c) \geq 200$	13/10/8 – 17/13/10
Admissible pressure differential	A	bar [psi]	30 [435]
	B	bar [psi]	330 [4785]

### Seal material for hydraulic fluids

Mineral oil			Ordering code
Mineral oil	HLP	according to DIN 51524	M
Flame-resistant hydraulic fluids			Ordering code
Emulsions	HFA-E	according to DIN 24320	M
Synthetic water solutions	HFA-S	according to DIN 24320	M
Water solutions	HFC	according to VDMA 24317	M
Phosphoric acid esters	HFD-R	according to VDMA 24317	V
Organic esters	HFD-U	according to VDMA 24317	V
Fast biodegradable hydraulic fluid			Ordering code
Triglycerides (rape seed oil)	HETG	according to VDMA 24568	M
Synthetic esters	HEES	according to VDMA 24568	V
Polyglycols	HEPG	according to VDMA 24568	V

## Characteristic curves (measured with HLP46, according to ISO 3968)

**H3XL**

Specific weight: < 0.9 kg/dm<sup>3</sup>

$\Delta p$ -Q characteristic curves for complete filters recommended  
 initial  $\Delta p$  for design = 1 bar [14.5 psi]

A proper filter design is enabled by our computer program  
 "BRFilterSelect".

Oil viscosity:   
 ——— 140 mm<sup>2</sup>/s [649 SUS]  
 - - - 68 mm<sup>2</sup>/s [315 SUS]  
 - - - 30 mm<sup>2</sup>/s [139 SUS]

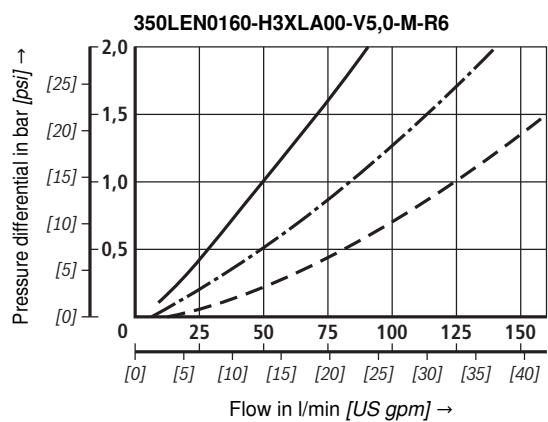
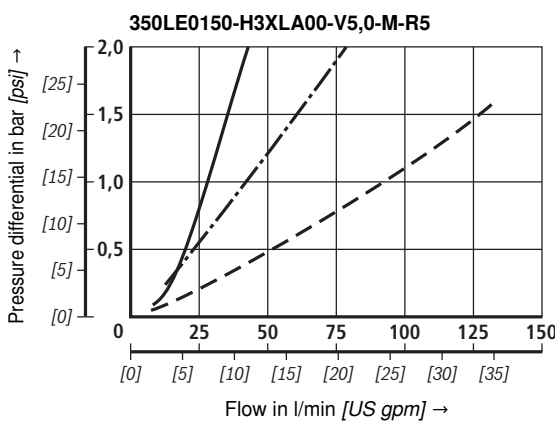
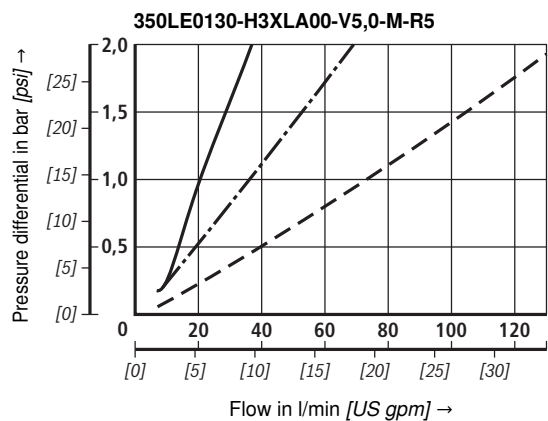
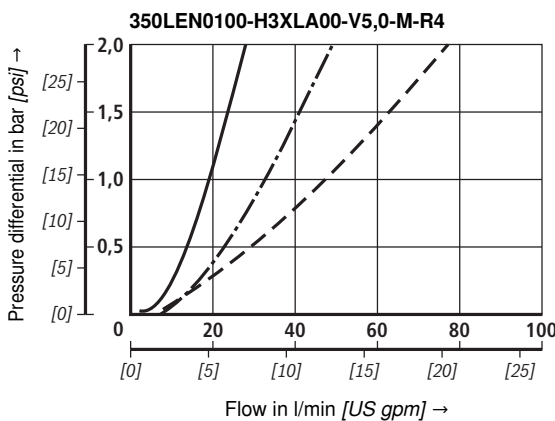
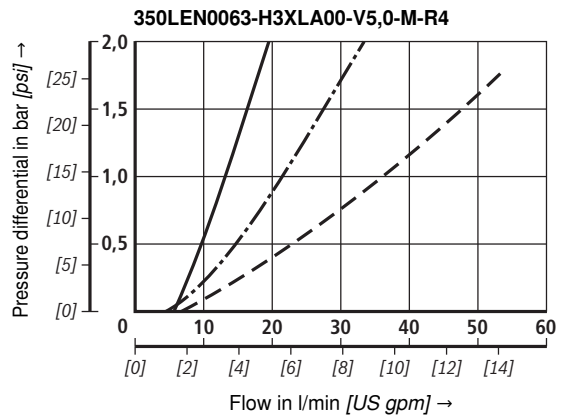
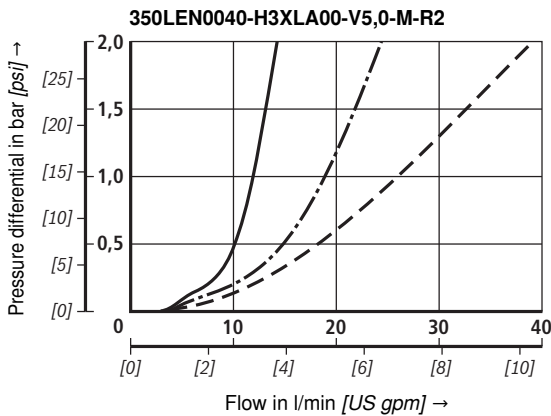

## Characteristic curves (measured with HLP46, according to ISO 3968)

## H3XL

Specific weight: < 0.9 kg/dm<sup>3</sup>

$\Delta p$ -Q characteristic curves for complete filters recommended  
initial  $\Delta p$  for design = 1 bar [14.5 psi]

A proper filter design is enabled by our computer program  
"BRFilterSelect".

Oil viscosity:  
 — 140 mm<sup>2</sup>/s [649 SUS]  
 - - - 68 mm<sup>2</sup>/s [315 SUS]  
 - - - 30 mm<sup>2</sup>/s [139 SUS]

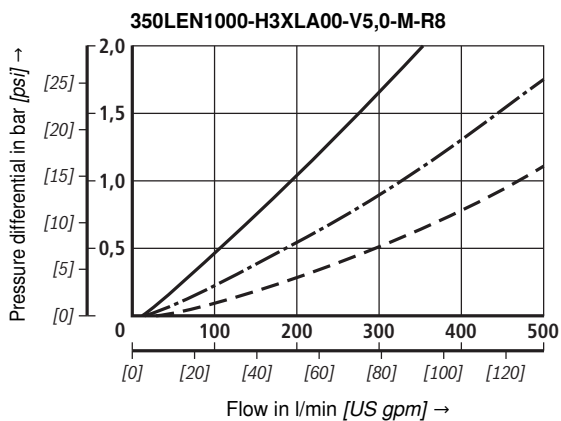
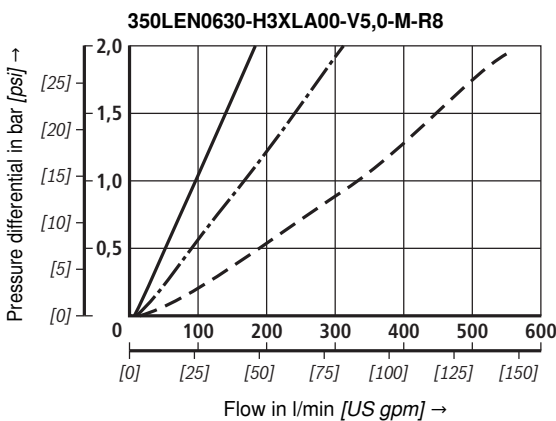
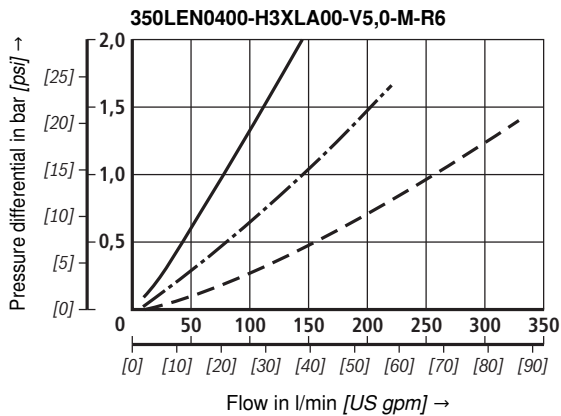
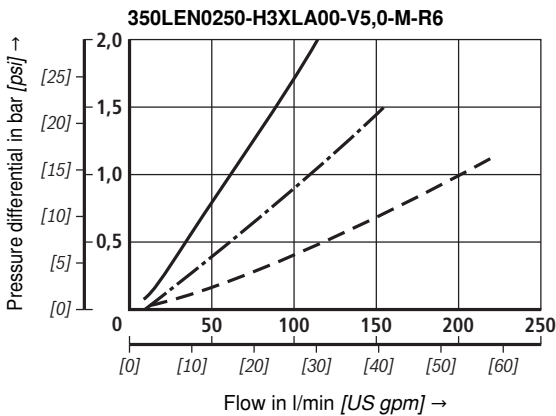

## Characteristic curves (measured with HLP46, according to ISO 3968)

## H10XL

Specific weight: < 0.9 kg/dm<sup>3</sup>

$\Delta p$ -Q characteristic curves for complete filters recommended  
initial  $\Delta p$  for design = 1 bar [14.5 psi]

A proper filter design is enabled by our computer program  
"BRFilterSelect".

Oil viscosity:   
 — 140 mm<sup>2</sup>/s [649 SUS]  
 - - 68 mm<sup>2</sup>/s [315 SUS]  
 - - - 30 mm<sup>2</sup>/s [139 SUS]

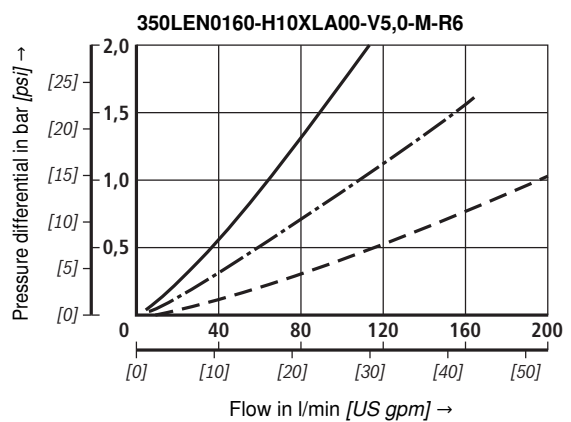
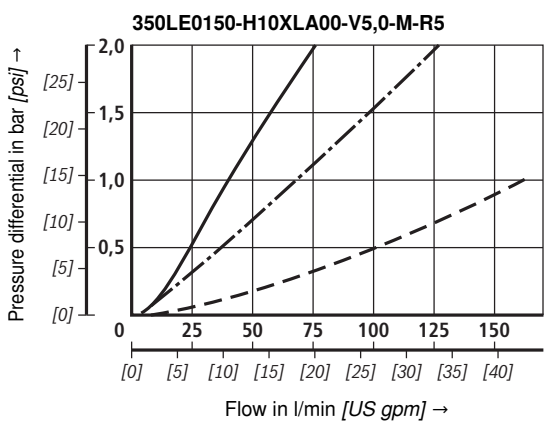
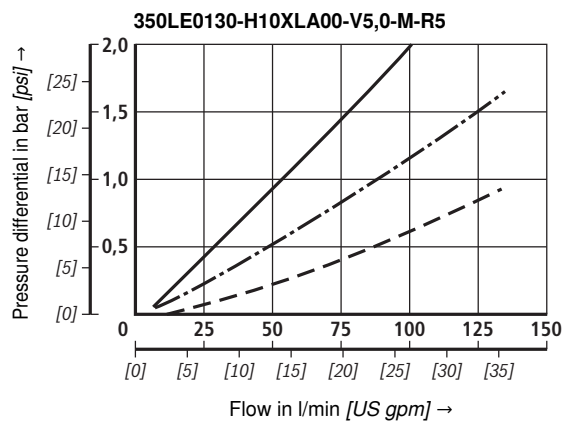
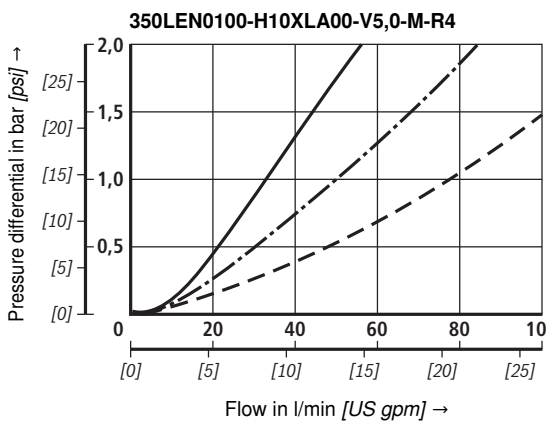
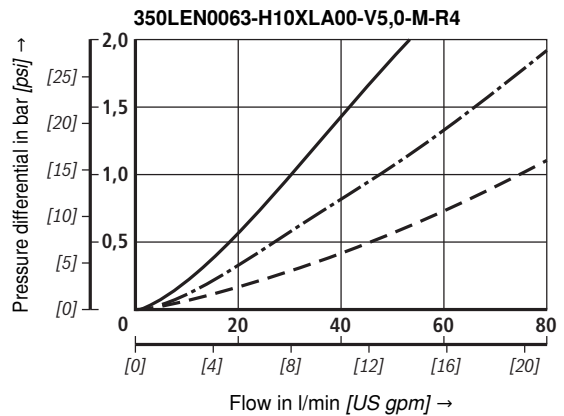
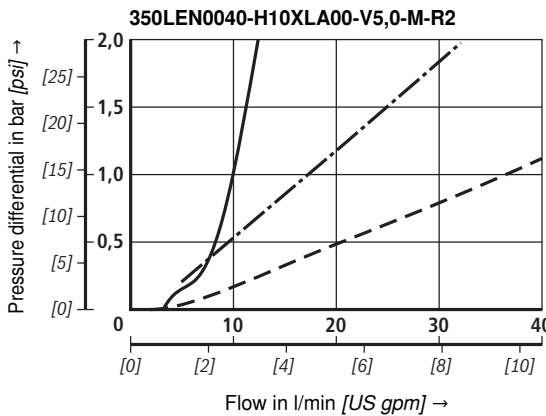

## Characteristic curves (measured with HLP46, according to ISO 3968)

## H10XL

Specific weight: < 0.9 kg/dm<sup>3</sup>

$\Delta p$ -Q characteristic curves for complete filters recommended  
initial  $\Delta p$  for design = 1 bar [14.5 psi]

A proper filter design is enabled by our computer program  
"BRFilterSelect".

Oil viscosity: ——— 140 mm<sup>2</sup>/s [649 SUS]  
- - - 68 mm<sup>2</sup>/s [315 SUS]  
- - - 30 mm<sup>2</sup>/s [139 SUS]

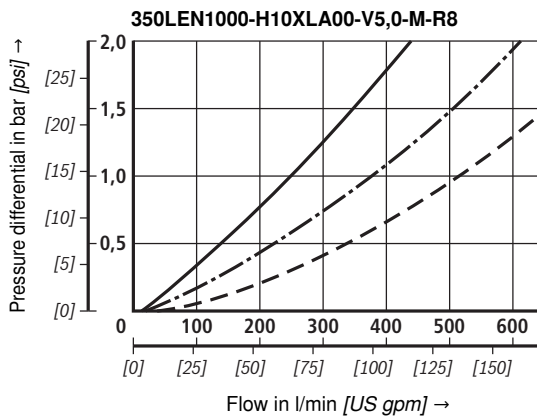
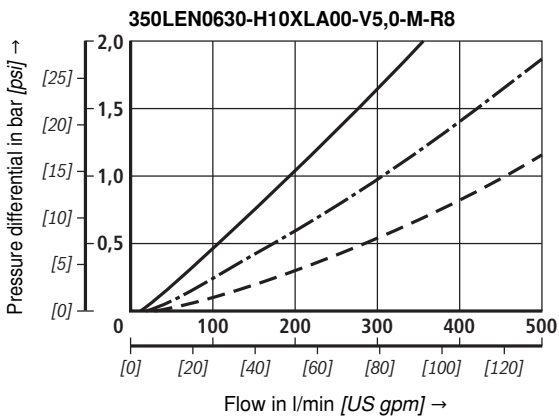
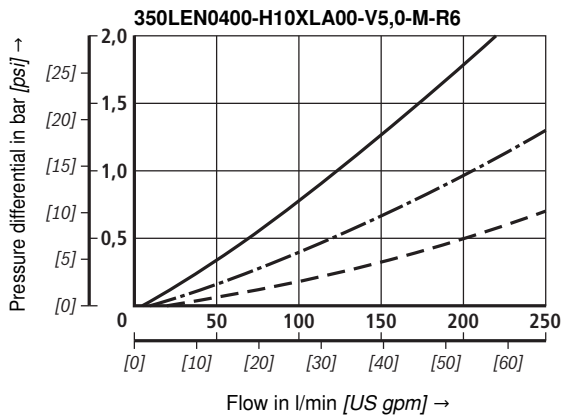
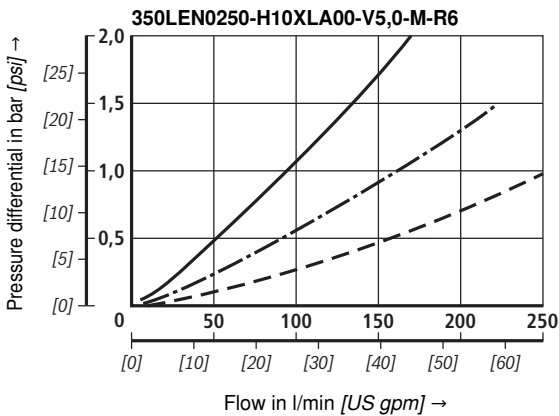

## Unit dimensions size 0040 to size 1000 (dimensions in mm [inch])

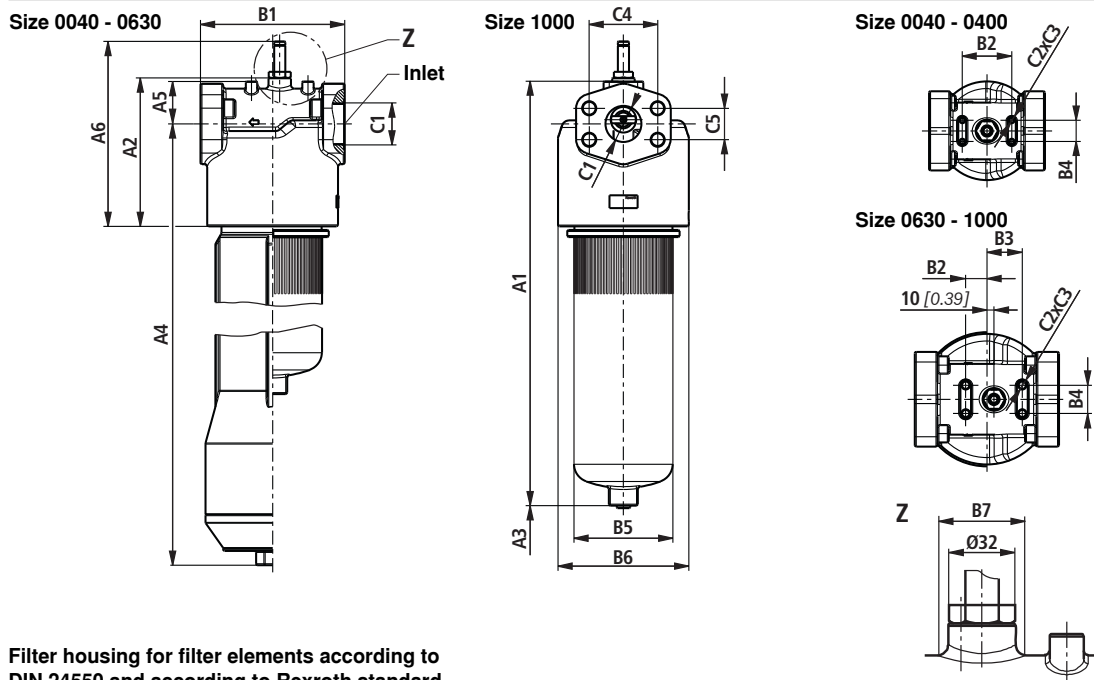

Filter housing for filter elements according to DIN 24550 and according to Rexroth standard

Type 350LE(N)	Content in l [US gal]	A1	A2	A3 <sup>1)</sup>	A4	A5	A6	B1 <sup>2)</sup>	B2
0040	0.25 [0.07]	203 [7.99]			158 [6.22]				
0063	0.35 [0.09]	266 [10.47]	115 [4.53]	80 [3.15]	221 [8.70]	25 [0.98]	167 [6.57]	92 [3.62]	65 [2.56]
0100	0.52 [0.14]	356 [14.02]			311 [12.24]				
0130	0.9 [0.24]	328 [12.91]			273 [10.75]				
0150	1.1 [0.29]	364 [14.33]	150 [5.91]		324 [12.76]	40 [1.57]	202 [7.95]	132 [5.20]	80 [3.15]
0160	1.3 [0.34]	322 [12.68]		140 [5.51]	262 [10.31]				
0250	1.9 [0.50]	412 [16.22]	170 [6.69]		352 [13.86]	50 [1.97]	222 [8.74]	164 [6.46]	70 [2.76]
0400	3.0 [0.79]	562 [22.13]			502 [19.76]				
0630	4.5 [1.19]	605 [23.82]		160 [6.30]	540 [21.26]				
1000	6.5 [1.72]	843 [33.19]	210 [8.27]	650 [25.59]	778 [30.63]	60 [2.36]	262 [10.31]	204 [8.03]	30 [1.18]

Type 350LE(N)	B3	B4	B5 Ø	B6 Ø	B7 Ø	Standard (ISO 228)	C1 U... (SAE J1926)	SAE flanges	C2	C3	C4	C5
0040						G 1/2	SAE 10 7/8-14 UNF-2B					
0063		30 [1.18]	64 [2.52]	85 [3.35]	47 [1.85]	G 1	SAE 12 1 1/16-12 UN-2B		M6	8 [0.32]		
0100												
0130		30 [1.18]	92 [3.62]	118 [4.65]	47 [1.85]	G 1 1/4	SAE 20 1 5/8-12 UN-2B					
0150												
0160												
0250		30 [1.18]	114 [4.49]	140 [5.51]	32 [1.26]	G 1 1/2	SAE 24 1 7/8-12 UN-2B	SAE 1 1/2" 6000 psi	M8		79.38 [3.13]	36.5 [1.44]
0400												
0630	50 [1.97]	40 [1.57]	140 [5.51]	185 [7.28]	32 [1.26]	G 2		SAE 2" 6000 psi	M12	12 [0.47]	96.82 [3.81]	44.45 [1.75]
1000			190 [7.48]									

<sup>1)</sup> Servicing height for filter element replacement

<sup>2)</sup> For SAE flanges dimension B1 is reduced by 4 mm [0.16 inch]

## Maintenance indicator (dimensions in mm [inch])

Pressure differential indicator with assembled switching element M12x1

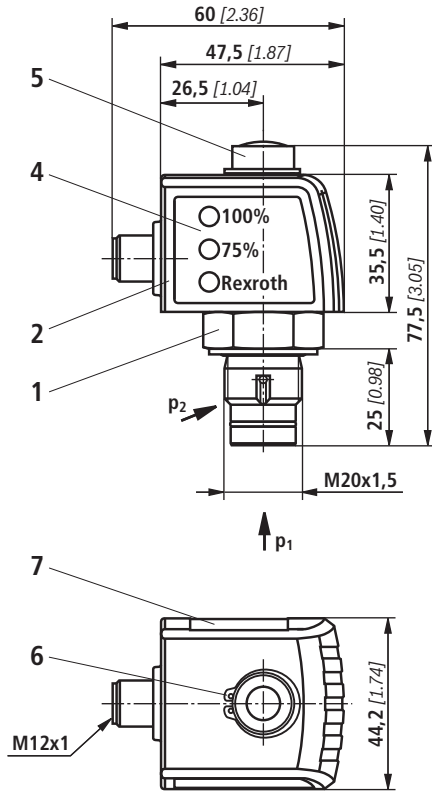

Pressure differential indicator with assembled switching element EN-175301-803

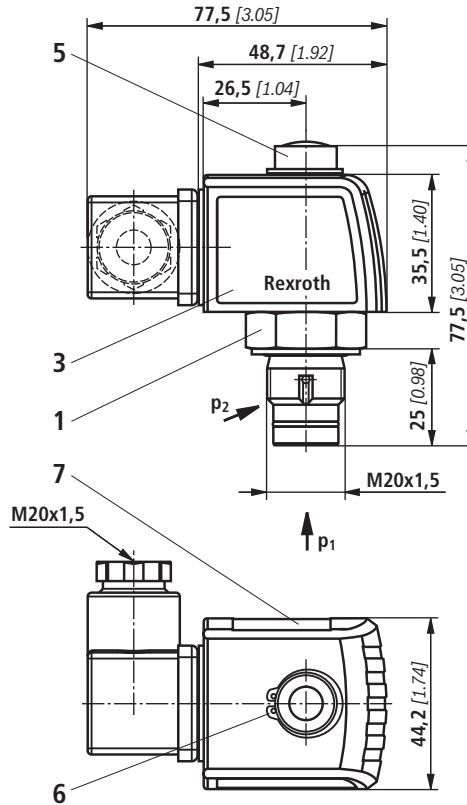

- 1 Mechanical optical maintenance indicator; max. tightening torque  $M_{A \max} = 50 \text{ Nm}$  [36.88 lb-ft]
- 2 Switching element with locking ring for electrical maintenance indicator (rotatable by  $360^\circ$ ); round plug-in connection M12x1, 4-pin
- 3 Switching element with locking ring for electrical maintenance indicator (rotatable by  $360^\circ$ ); rectangular plug-in connection EN175301-803
- 4 Housing with three LEDs: 24 V =  
Green: Stand-by  
Yellow: Switching point 75 %  
Red: Switching point 100 %
- 5 Optical indicator bistable
- 6 Locking ring DIN 471-16x1,  
**Material no. R900003923**
- 7 Name plate

### Notes:

Presentation contains mechanical optical maintenance indicator (1) and electronic switching element (2) (3).  
Switching elements with increased switching power at request.

## Spare parts

### Mechanical optical maintenance indicator

W O - D01 - - - 160

Maintenance indicator	= W
Mechanical optical indicator	= O
<b>Design</b>	
Pressure differential, design 01	= D01
<b>Switching pressure</b>	
5.0 bar	= 5.0
2.2 bar	= 2.2
1.5 bar	= 1.5

	<b>Max. operating pressure</b>
	D01-1,5; D01-2,2
160 =	160 bar [2321 psi]
	D01-5,0
450 =	450 bar [6527 psi]
	<b>Seal</b>
M =	NBR seal
V =	FKM seal

Mechanical optical maintenance indicator	Material no.
WO-D01-5,0-M-450	R901025313
WO-D01-2,2-M-160	R901025312
WO-D01-1,5-M-160	R928038781

### Seal kit

D 350LE - - -

Seal kit	= D
Series	= 350LE
<b>Size</b>	
Size 0040-0100	= N0040-0100
Size 0130-0150	= 0130-0150
Size 0160-0400	= N0160-0400
Size 0630	= N0630
Size 1000	= N1000

	<b>Seal</b>
M =	NBR seal
V =	FKM seal

Seal kit	Material no.
D350LEN0040-0100-M	R928028527
D350LE0130-0150-M	R928028530
D350LEN0160-0400-M	R928028532
D350LEN0630-M	R928028536
D350LEN1000-M	R928028537

## Installation, commissioning and maintenance

### Installation of the filter

Verify operating overpressure with name plate information. Remove the blanking plugs in the filter inlet and outlet. Screw the filter head (1) to the fastening device, considering flow direction (direction arrows) and servicing height of the element. Make sure that the components are assembled in a stressless form. The housing must be grounded.

The filter must preferably be installed with the filter bowl (2) downward. The maintenance indicator must be arranged in a well visible way.

### Connection of the electronic maintenance indicator

Basically, the filter is equipped with mechanical optical maintenance indicator (4). The electronic maintenance indicator is connected via the switching element (6) with 1 or 2 switching points, which is attached to the mechanical optical maintenance indicator and held by means of the locking ring.

### When must the filter element be exchanged or cleaned respectively?

- After initial start-up of the system, the filter element is to be exchanged.
- Upon start-up in cold condition, the red pushbutton of the optical maintenance indicator (4) may jump out and an electrical signal is output via the switching element. Only push the red pushbutton in again after the operating temperature has been reached. If it jumps out again immediately or if the electrical signal has not gone out at operating temperature, the filter element must be exchanged or cleaned respectively after the end of the shift.
- The filter element should be replaced or cleaned after max. 6 months at the latest.

### Element exchange

- Switch off the system and discharge the filter on the pressure side.
- Screw off the filter bowl (2) by anticlockwise rotation. Clean the filter housing in a suitable medium.
- Remove the filter element (3) from the spigot in the filter head by turning it slightly.
- Check the seal ring in the filter bowl for position and damage. If necessary, these parts are to be renewed.
- Replace filter elements H...XL, clean filter elements G....
- The efficiency of the cleaning process depends on the type of dirt and the amount of the pressure differential before the filter element exchange. If the differential pressure after the filter element exchange exceeds 150 % of the value of a brand-new filter element, the G... element also needs to be replaced.
- Check whether the type designation or material number on the replacement element corresponds to the type designation/material number on the name plate of the filter.
- Install replaced or cleaned filter element on the spigot again by slightly turning it.
- Now screw in the filter bowl to stop (torque 50 Nm <sup>+10 Nm</sup>).

## Quality and standardization

The inline filters for hydraulic applications according to 51422 are pressure holding equipment according to article 1, section 2.1.4 of the pressure equipment directive 97/23/EC (PED). However, on the basis of the exception in article 1, section 3.6 of the PEG, hydraulic filters are exempt from the PED if they are not classified higher than category I (guideline 1/19). They do not receive a CE mark.

### Use in explosive areas according to directive 94/9/EC (ATEX)

The inline filters according to 51422 are no equipment or components in the sense of directive 94/9/EC and are not provided with a CE mark.

When using the inline filters according to 51422 in explosive areas, potential equalization has to be ensured.

According to DIN EN 60079-11, the electronic maintenance indicators WE-1SP-M12x1 are simple, electronic operating equipment not having an own voltage source. This simple, electronic operating equipment may - according to DIN EN 60079-14 - in intrinsically safe electrical circuits (EEx ib) be used in systems for device group II, category 2G (zone 1) and category 3G (zone 2) without marking and certification. The operating equipment is assigned to explosion group II B and temperature class T5.

Possible circuit according to DIN EN 60079-14

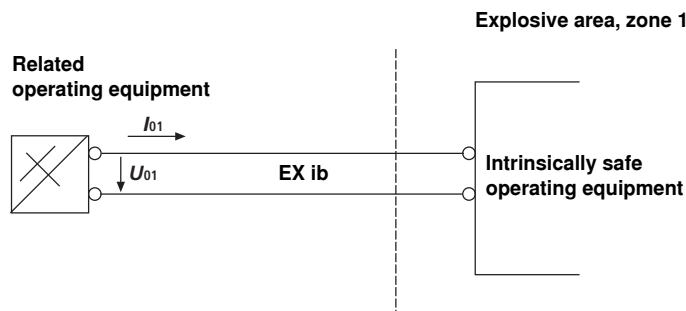

The manufacturer's declaration according to DIN EN 13463 is available for this filter separately, with Material no. R928028899.

## Notes

---

© This document, as well as the data, specifications and other information set forth in it, are the exclusive property of Bosch Rexroth AG. It may not be reproduced or given to third parties without its consent. The data specified above only serve to describe the product. No statements concerning a certain condition or suitability for a certain application can be derived from our information. The information given does not release the user from the obligation of own judgment and verification. It must be remembered that our products are subject to a natural process of wear and aging.