

The Drive & Control Company

Rexroth
Bosch Group

Duplex tank mounted return line filter with filter element according to DIN 24550

Type 10TDN0040 to 1000; 10TD2000 and 2500

RE 51454

Edition: 12.13

Replaces: 11.13

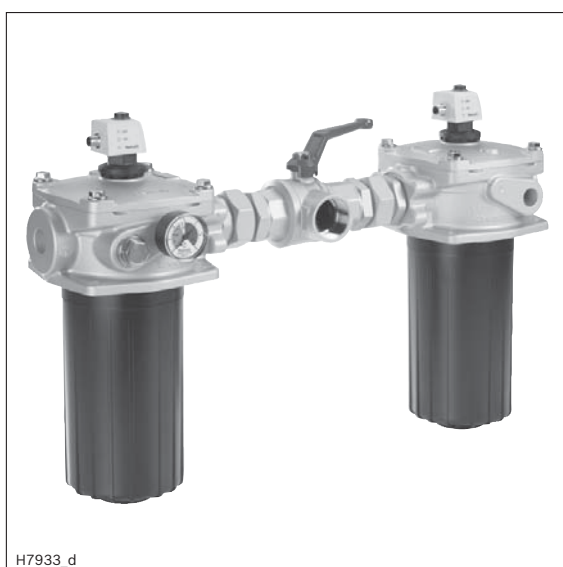

H7933_d

- ▶ Size according to **DIN 24550**: 0040 to 1000
- ▶ Additional sizes: 2000, 2500
- ▶ Nominal pressure 10 bar [145 psi]
- ▶ Connection up to 3"
- ▶ Operating temperature -10 °C to +100 °C [14 °F to 212 °F]

Features

The duplex tank mounted return line filters are designed for installation on fluid tanks. Their function is to separate solid materials from fluids.

They distinguish themselves by the following:

- ▶ Filter for tank mounting
- ▶ Special highly efficient filter materials
- ▶ Filtration of very fine particles and high dirt holding capacity across a broad pressure differential range
- ▶ High collapse rating of the filter elements
- ▶ Optional mechanical optical maintenance indicator with memory function
- ▶ Various, optional electronic switching elements, modular design
- ▶ Filters are equipped standard with a bypass valve integrated in the filter housing
- ▶ Optional measuring port

Contents

Features	1
Ordering code filter	2, 3
Preferred types	4
Ordering code accessories	5 ... 7
Symbols	8
Function, section	9
Technical data	10, 11
Compatibility with hydraulic fluids	11
Characteristic curves	12 ... 19
Dimensions	20 ... 23
Maintenance indicator	24
Ordering code spare parts	25 ... 28
Assembly, commissioning and maintenance	29, 30
Tightening torques	30
Directives and standardization	31, 32

RE 51454, edition: 2013-12, **Bosch Rexroth AG**

2/32 10TDN0040-1000; 10TD2000/2500 | RE 51454

Ordering code

Filter

01	02	03	04	05	06	07	08	09	10	10	10	10	10	10	10
10TD			- 1X /		A00	-	-	-	-	-	-	-	-	-	-

Series

01	Duplex tank mounted return line 10 bar [145 psi]	10TD
----	--	------

Filter element

02	With filter element according to DIN 24550 (only with frame size 0040-1000)	N
----	--	---

Size

03	TDN... (filter element according to DIN 24550)	0040 0063 0100 0160 0250 0400 0630 1000
	TD... (filter elements according to Bosch Rexroth standard)	2000 2500

04	Component series 10 ... 19 (10 ... 19: Unchanged installation and connection dimensions)	1X
----	---	----

Filter rating in µm

05	Nominal	Paper, not cleanable	P10 P25
	Nominal	Stainless steel wire mesh, cleanable	G10 G25 G40 G60 G100
	Absolute (ISO 16889; $\beta_{x(e)} \geq 200$)	Non-woven glass fiber media, not cleanable	H3XL H6XL H10XL H20XL
	Absolute (ISO 16889; $\beta_{x(e)} \geq 200$)	Water-absorbing, not cleanable	AS6 AS10 AS20

Pressure differential

06	Maximum admissible pressure differential of the filter element 30 bar [435 psi] (with bypass valve)	A00
----	---	-----

Maintenance indicator (1 unit per filter side)

07	Without maintenance indicator – bypass cracking pressure 3.5 bar [51 psi]	0
	Pressure gauge ¹⁾ 0...6 bar [0...87 psi] opposite of connection – bypass cracking pressure 3.5 bar [51 psi]	MB
	Maintenance indicator, cover-mounted, aluminum, mech.-optical, switching pressure 2.2 bar [32 psi], with additional pressure gauge ¹⁾ 0...6 bar [0...87 psi] opposite of connection – bypass cracking pressure 3.5 bar [51 psi]	MBV2,2
	Maintenance indicator, polyamide, mech.-optical, switching pressure 2.2 bar [32 psi] – bypass cracking pressure 3.5 bar [51 psi]	P2,2
	Maintenance indicator, aluminum, mech.-optical, switching pressure 0.8 bar [11.6 psi] – bypass cracking pressure 3.5 bar [51 psi]	V0,8
	Maintenance indicator, aluminum, mech.-optical, switching pressure 1.5 bar [21.8 psi] – bypass cracking pressure 3.5 bar [51 psi]	V1,5
Maintenance indicator, aluminum, mech.-optical, switching pressure 2.2 bar [32 psi] – bypass cracking pressure 3.5 bar [51 psi]	V2,2	

Seal

08	NBR seal	M
	FKM seal	V

¹⁾ If the manometer option is chosen, the maximum pressure rating for the 10TDN filter is reduced from 10 bar [145 psi] to 6 bar [87 psi].

Ordering code Filter

01	02	03	04	05	06	07	08	09	10	10	10	10	10	10
10TD			- 1X /		A00	-	-	-	-	-	-	-	-	-

Connection

09	Frame size	0040-0100	0160-0250	0400	0630	1000	2000-2500	
	Connection							
	G 1	•						R4
	G 1 1/4		X					R5
	G 1 1/2		•					R6
	SAE 2 1/2" - 3000 psi			•	•			S9
	SAE 3" - 3000 psi					•	•	S10
	SAE 16"	X						U9
	SAE 24"		X					U6
		<input checked="" type="checkbox"/> Standard connection <input type="checkbox"/> Optional connection						

Supplementary information (multiple specifications possible)

10	Breathing filter with oil mist separator (only size 0040-0100)	FN
	Additional threaded couplings, G 1/4, lateral	M
	Installation plate (only size 0400-2500)	MP
	Without bypass valve	NB
	Outlet pipe L110 mm [4.33 inch] (only size 0040-0100, from size 0160 see chapter "Accessories")	R110
	Outlet pipe L150 mm [5.91 inch] (only size 0040-0100, from size 0160 see chapter "Accessories")	R150

Order example:

10TDN0100-1X/H10XLA00-P2,2-M-R4

Further versions (filter materials, connections, ...) are available on request.

4/32 10TDN0040-1000; 10TD2000/2500 | RE 51454

Preferred types

Filter rating 3 µm, 6 µm, 10 µm and 20 µm

Filter type	Flow in l/min [gpm] with v = 30 mm ² /s [142 SUS] and Δp = 0.5 bar [7.25 psi]	Connection	Material no.	Connection	Material no.
10TDN0040-1X/H3XLA00-P2,2-M-...	23 [6.1]	..R4	R928051464	..U9	R928051605
10TDN0063-1X/H3XLA00-P2,2-M-...	35 [9.2]	..R4	R928051465	..U9	R928051606
10TDN0100-1X/H3XLA00-P2,2-M-...	52 [13.7]	..R4	R928051466	..U9	R928051607
10TDN0160-1X/H3XLA00-P2,2-M-...	105 [27.7]	..R6	R928051467	..U6	R928051608
10TDN0250-1X/H3XLA00-P2,2-M-...	160 [42.3]	..R6	R928051468	..U6	R928051609
10TDN0400-1X/H3XLA00-P2,2-M-...-MP	290 [76.6]	..S9	R928051469		
10TDN0630-1X/H3XLA00-P2,2-M-...-MP	410 [108.3]	..S9	R928051470		
10TDN1000-1X/H3XLA00-P2,2-M-...-MP	560 [147.9]	..S10	R928051471		
10TD2000-1X/H3XLA00-P2,2-M-...-MP	900 [237.7]	..S10	R928051472		
10TD2500-1X/H3XLA00-P2,2-M-...-MP	1100 [290.6]	..S10	R928051473		
10TDN0040-1X/H6XLA00-P2,2-M-...	37 [9.8]	..R4	R928051395	..U9	R928051600
10TDN0063-1X/H6XLA00-P2,2-M-...	49 [12.9]	..R4	R928051396	..U9	R928051601
10TDN0100-1X/H6XLA00-P2,2-M-...	70 [18.5]	..R4	R928051397	..U9	R928051602
10TDN0160-1X/H6XLA00-P2,2-M-...	150 [39.6]	..R6	R928051398	..U6	R928051603
10TDN0250-1X/H6XLA00-P2,2-M-...	200 [52.8]	..R6	R928049477	..U6	R928051604
10TDN0400-1X/H6XLA00-P2,2-M-...-MP	410 [108.3]	..S9	R928051399		
10TDN0630-1X/H6XLA00-P2,2-M-...-MP	510 [134.7]	..S9	R928051458		
10TDN1000-1X/H6XLA00-P2,2-M-...-MP	870 [229.8]	..S10	R928049321		
10TD2000-1X/H6XLA00-P2,2-M-...-MP	1250 [330.1]	..S10	R928051461		
10TD2500-1X/H6XLA00-P2,2-M-...-MP	1350 [356.5]	..S10	R928051463		
10TDN0040-1X/H10XLA00-P2,2-M-...	43 [11.3]	..R4	R928048600	..U9	R928051613
10TDN0063-1X/H10XLA00-P2,2-M-...	62 [16.4]	..R4	R928048601	..U9	R928051614
10TDN0100-1X/H10XLA00-P2,2-M-...	80 [21.1]	..R4	R928048602	..U9	R928051615
10TDN0160-1X/H10XLA00-P2,2-M-...	190 [50.2]	..R6	R928051508	..U6	R928051616
10TDN0250-1X/H10XLA00-P2,2-M-...	260 [68.7]	..R6	R928048604	..U6	R928051617
10TDN0400-1X/H10XLA00-P2,2-M-...-MP	460 [121.5]	..S9	R928048991		
10TDN0630-1X/H10XLA00-P2,2-M-...-MP	560 [147.9]	..S9	R928051424		
10TDN1000-1X/H10XLA00-P2,2-M-...-MP	970 [256.2]	..S10	R928048992		
10TD2000-1X/H10XLA00-P2,2-M-...-MP	1350 [356.6]	..S10	R928048993		
10TD2500-1X/H10XLA00-P2,2-M-...-MP	1450 [383.0]	..S10	R928048994		
10TDN0040-1X/H20XLA00-P2,2-M-...	62 [16.4]	..R4	R928051386	..U9	R928051595
10TDN0063-1X/H20XLA00-P2,2-M-...	80 [21.1]	..R4	R928051387	..U9	R928051596
10TDN0100-1X/H20XLA00-P2,2-M-...	95 [25.1]	..R4	R928048958	..U9	R928051597
10TDN0160-1X/H20XLA00-P2,2-M-...	260 [68.7]	..R6	R928051388	..U6	R928051598
10TDN0250-1X/H20XLA00-P2,2-M-...	320 [84.5]	..R6	R928051389	..U6	R928051599
10TDN0400-1X/H20XLA00-P2,2-M-...-MP	560 [147.9]	..S9	R928051390		
10TDN0630-1X/H20XLA00-P2,2-M-...-MP	630 [166.4]	..S9	R928051391		
10TDN1000-1X/H20XLA00-P2,2-M-...-MP	1270 [335.5]	..S10	R928051392		
10TD2000-1X/H20XLA00-P2,2-M-...-MP	1600 [422.7]	..S10	R928051393		
10TD2500-1X/H20XLA00-P2,2-M-...-MP	1680 [443.8]	..S10	R928051394		

Bosch Rexroth AG, RE 51454, edition: 2013-12

Ordering code Accessories

Electronic switching element for maintenance indicators

If an electronic switching element with signal suppression up to 30 °C [86 °F] is used (WE-2SPSU-M12X1, **R928028411**), the aluminum version of the mechanical-optical maintenance indicator **must** be used. In the filter type key, these maintenance indicators are referred to as "V0,8", "V1,5" or "V2,2".

In this connection, also refer to the chapter "Maintenance indicator".

The temperature-controlled signal processing does not work with mechanical-optical maintenance indicators made of polyamide, "P2,2".

01	02	03
WE	-	-

Maintenance indicator

01	Electronic switching element	WE
----	------------------------------	-----------

Type of signal

02	1 switching point	1SP
	2 switching points, 3 LED	2SP
	2 switching points, 3 LED and signal suppression up to 30 °C [86 °F]	2SPSU

Connector

03	Round plug-in connection M12x1, 4-pole	M12x1
	Rectangular connector, 2-pole, design A according to EN-175301-803, only possible with "1SP" type of signal.	EN175301-803

Material numbers of the electronic switching elements

With the "mechanical-optical maintenance indicator" option (V..., P...), two mechanical optical maintenance indicators are installed at the factory. So you must always order two electric switching elements as optional accessories.

Material no.	Type	Signal	Switching points	Connector	LED
R928028409	WE-1SP-M12x1	Changeover	1	M12x1	No
R928028410	WE-2SP-M12x1	Normally open (at 75 %) / normally closed contact (at 100 %)	2		3 pieces
R928028411	WE-2SPSU-M12x1				
R928036318	WE-1SP-EN175301-803	Normally closed contact	1	EN 175301-803	No

6/32 10TDN0040-1000; 10TD2000/2500 | RE 51454

Ordering code

Accessories

(dimensions in mm [inch])

Mating connectors according to IEC 60947-5-2

For electronic switching element with round plug-in connection M12x1

Mating connector suitable for K24 4-pole, M12x1 with screw connection, cable gland Pg9.

Material no. R900031155

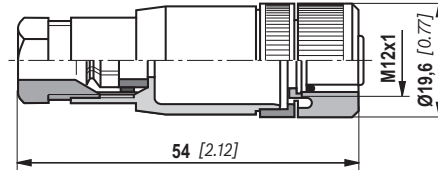

Mating connector suitable for K24-3m 4-pole, M12x1 with potted-in PVC cable, 3 m long.

Line cross-section: 4 x 0.34 mm²

Core marking: 1 Brown 2 White
3 Blue 4 Black

Material no. R900064381

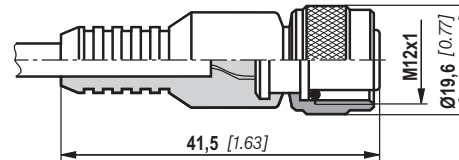

For more round plug-in connections and technical data refer to data sheet 08006.

Order example:

Duplex tank mounted return line filter with mechanical-optical maintenance indicator for $p_{nom.} = 10 \text{ bar}$ [145 psi], size 0040, with filter element 10 μm and electronic switching element M12x1 with 1 switching point for hydraulic fluid mineral oil HLP according to DIN 51524.

Filter with mech. optical maintenance indicator: 10TDN0040-1X/H10XLA00-P2,2-M-R4 Material no: R928048600

Electr. switching element: WE-1SP-M12x1 Material no: R928028409

Mating connector: Mating connector suitable for K24 4-pole, M12x1 with screw connection, cable gland Pg9 Material no. R900031155

Ordering code

Accessories

(dimensions in mm [inch])

Outlet pipe

The outlet pipe is push connected onto the filter bowl outlet piece. Correct seat is confirmed by an audible click. After the connection is made, the outlet pipe can no longer be removed.

Outlet pipe with push connection size 0040-0100

Material no.	Description
R928038744	ACC-R-10TEN0040-0100-R110
R928038745	ACC-R-10TEN0040-0100-R150
R928038746	ACC-R-10TEN0040-0100-R250

Outlet pipe with threaded connection from size 0160

Dimensions and range

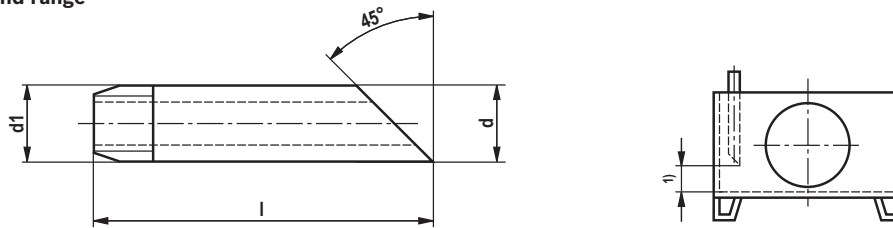

¹⁾ Recommended distance to tank bottom (unless otherwise specified): 60...160 mm [2.4...6.3 inch]
From a pipe length of 400 mm [15.75 inch], we strongly recommend fixing the outlet pipe with an internal tank pipe bracket.

DN	Dimensions			Galvanized	ES (stainless)	
	d	d1	l	Denomination: ROHR AB23-03/R...	Denomination: ROHR AB23-03/R...-ES	
				Material no.	Material no.	
40 [1.57]	48.3 [1.90]	R 1 1/2	250 [9.84]	1 1/2 L = 250	R900109501	R900062066
			400 [15.75]	1 1/2 L = 400	R900083146	R900074878
			800 [31.50]	1 1/2 L = 800	R900029854	-
			1300 [51.18]	1 1/2 L = 1300	R900302230	-
			2000 [78.74]	1 1/2 L = 2000	R900229461	-
50 [1.97]	60.3 [2.37]	R 2	400 [15.75]	2 L = 400	R900727174	R900987657
			800 [31.50]	2 L = 800	R900029856	R900226706
80 [3.15]	88.9 [3.50]	R 3	160 [6.30]	3 L = 160	R900062845	-
			200 [7.87]	3 L = 200	R900061785	R900062067
			350 [13.78]	3 L = 350	R900084137	-
			650 [25.59]	3 L = 650	R900076923	R900757513
			800 [31.50]	3 L = 800	R900029838	R900987653

Thread: Whitworth pipe thread according to DIN 2999 part 1, poppet 1:16
Material/surface treatment: St 33-1 according to DIN 17100/galvanized (B) according to DIN 2444 1.4541

Order example/search term

Pipe according to DIN 2440 (ISO 65) with thread R 1 1/2 and L = 250 mm [9.84 inch], galvanized:
ROHR AB23-03/R 1 1/2 L = 250 Material no. R900109501

8/32 10TDN0040-1000; 10TD2000/2500 | RE 51454

Symbols

Duplex tank mounted return line filter with bypass and mechanical indicator

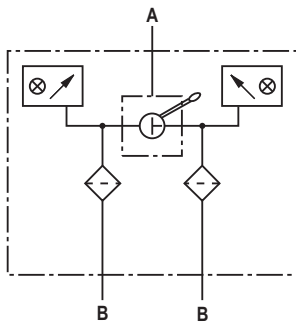
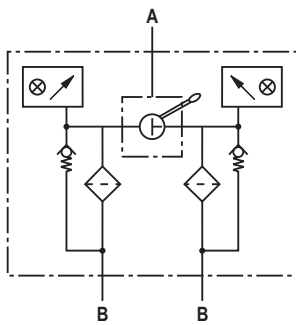

Duplex tank mounted return line filter without bypass and with mechanical indicator

Electronic switching element
for maintenance indicator

Switching element Connector

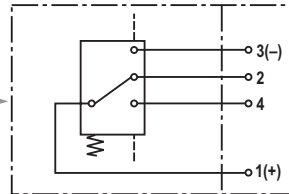

WE-1SP-M12x1

Switching element Connector

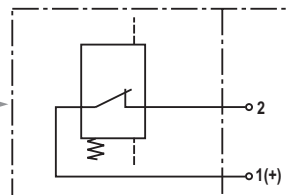

WE-1SP-EN175301-803

Switching element Connector

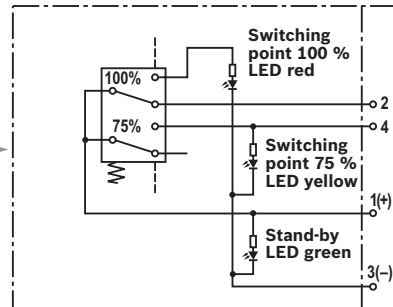

WE-2SP-M12x1

Circuit diagram drawn in plugged condition (operating state)

Switching element Connector

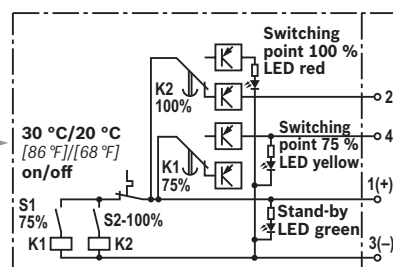

WE-2SPSU-M12x1

Circuit diagram drawn in plugged condition at temperature > 30 °C [86 °F] (operating state)

Function, section

The switchable duplex tank mounted return line filter is located in the return line for direct attachment onto the tank of a hydraulic or lubrication system. It can also be used as filling or bypass filter. The filter basically consists of filter head (1) and switch-over fitting (2), filter bowl (3), cover (4), filter element (5) as well as a bypass valve (6), by default.

Optionally, the filter is equipped with mechanical optical maintenance indicator (7). The electronic maintenance indicator is connected via the electronic switching elements (8) with 1 or 2 switching points (see p. 5), which have to be ordered separately. For every filter housing, a switching element is required. The electronic switching element (8) is attached to the mechanical optical maintenance indicator (7) and held by means of a locking ring.

Depending on the filter size, more additional functions are available – e.g. a breathing filter, surge protection (only for

size 0040 - 0100) or outlet pipes in different lengths – in this connection, also refer to the chapter "Accessories".

During operation, the hydraulic fluid reaches the filter housing via the inlet; here, it flows through the filter element (5) from the outside to the inside and is cleaned according to the filter rating. The dirt particles filtered out collect in the filter element (5). Via the outlet, the filtered hydraulic fluid enters the tank. In case of contamination, the necessary filter element exchange is displayed by the relevant maintenance indicator (7). Within the course of this exchange, you should also exchange the breathing filter element if equipped (only with size 0040-0100). The system is manually switched to the clean filter element by means of the switch-over fitting (2). Continuous flow is guaranteed during the switching process.

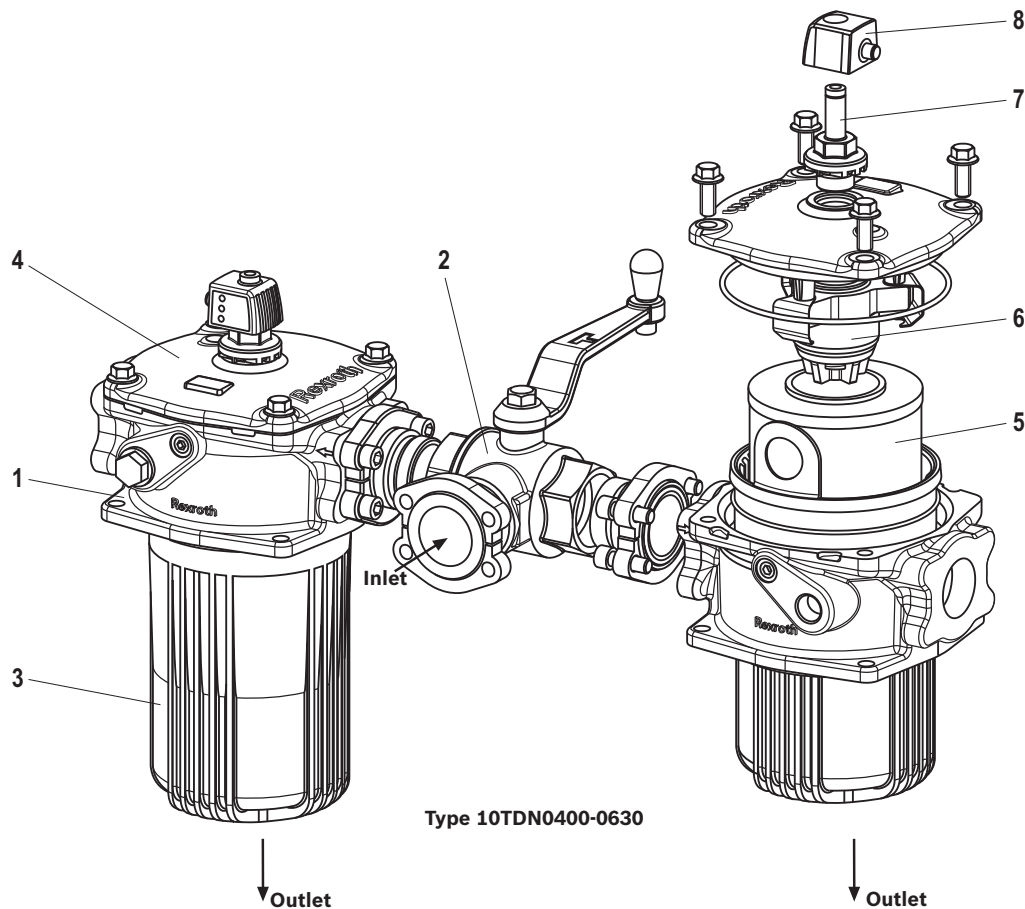

RE 51454, edition: 2013-12, Bosch Rexroth AG

10/32 10TDN0040-1000; 10TD2000/2500 | RE 51454

Technical data

(For applications outside these parameters, please consult us!)

general							
Weight	Size	0040	0063	0100	0160	0250	
	kg [lbs]	4.46 [9.81]	4.86 [10.7]	5.26 [11.6]	14 [30.8]	15 [33]	
	Size	0400	0630	1000	2000	2500	
	kg [lbs]	23 [50.6]	27 [59.4]	61 [134.2]	68 [149.9]	79 [174.1]	
Installation position	Vertical						
Ambient temperature range	°C [°F]	-10...+100 [14...+212] (short periods down to -30 [-22])					
Material	- Filter cover	Carbon fiber reinforced plastic (sizes 0040...0100) Aluminum (sizes 0160...2500)					
	- Filter head	Aluminum					
	- Filter bowl	Carbon fiber reinforced plastic (sizes 0040...0630) Aluminized steel (sizes 1000...2500)					
	- Optical maintenance indicator	(P2,2)	Plastic PA6				
		(V...)	Aluminum				
	- Bypass valve	Plastic					
	- Electronic switching element	Plastic PA6					
	- Pressure gauge	Plastic					
	- Seals	NBR / FKM					

hydraulic		
Maximum operating pressure	bar [psi]	10 [145] If the manometer option is chosen, the maximum pressure rating for the 10TDN filter is reduced from 10 bar [145 psi] to 6 bar [87 psi].
Hydraulic fluid temperature range	°C [°F]	-10...+100 [+14...+212]
Minimum conductivity of the medium	pS/m	300
Fatigue strength according to ISO 10771	Load cycles	> 10 ⁵ with operating pressure
Type of pressure measurement of the maintenance indicator	Back pressure	
Assignment: Response pressure of the maintenance indicator/cracking pressure of the bypass valve	bar [psi]	Response pressure of the maintenance indicator
		Cracking pressure of the bypass valve
		Without maintenance indicator
		With pressure gauge
		V0,8 ± 0.15 [11.6 ± 2.2]
		V1,5 ± 0.2 [21.8 ± 2.9]
V2,2 ± 0.3 [31.9 ± 4.4]		
P2,2 + 0.45/-0.25 [31.9 (+6.4/-3.6)]	3.5 ± 0.35 [50.8 ± 5.1]	
Filtration direction	From the outside to the inside	

Bosch Rexroth AG, RE 51454, edition: 2013-12

Technical data

(For applications outside these parameters, please consult us!)

electric (electronic switching element)				
Electrical connection	Round plug-in connection M12x1, 4-pole			Standard connection EN 175301-803
Version	1SP-M12x1	2SP-M12x1	2SPSU-M12x1	1SP-EN175301-803
Contact load, direct voltage	A _{max.}	1		
Voltage range	V _{max.}	150 (AC/DC)	10-30 (DC)	250 (AC)/200 (DC)
Max. switching power with resistive load	W	20		70
Switching type	- 75 % signal	-	Normally open contact	-
	- 100 % signal	Changeover	Normally closed contact	Normally closed contact
	- 2SPSU		Signal interconnection at 30 °C [86 °F], return switching at 20 °C [68 °F]	
Display via LEDs in the electronic switching element 2SP...		Stand-by (LED green); 75 % switching point (LED yellow) 100 % switching point (LED red)		
Protection class according to EN 60529 IP 65		IP 67		IP 65
Ambient temperature range	°C [°F]	-25...+85 [-13...+185]		
For direct voltage above 24 V, spark extinguishing is to be provided for protecting the switching contacts.				
Weight	Electronic switching element: - With round plug-in connection M12x1	kg [lbs]	0.1 [0.22]	

Filter element			
Glass fiber paper H..XL	Single-use element on the basis of inorganic fiber		
		Filtration ratio according to ISO 16889 up to $\Delta p = 5 \text{ bar [72.5 psi]}$	Achievable oil cleanliness according to ISO 4406 (SAE-AS 4059)
Particle separation	H20XL	$\beta_{20(c)} \geq 200$	19/16/12 ... 22/17/14
	H10XL	$\beta_{10(c)} \geq 200$	17/14/10 ... 21/16/13
	H6XL	$\beta_{6(c)} \geq 200$	15/12/10 ... 19/14/11
	H3XL	$\beta_{3(c)} \geq 200$	13/10/8 ... 17/13/10
Admissible pressure differential "A"	bar [psi]	30 [435]	

Compatibility with hydraulic fluids

Hydraulic fluid	Classification	Suitable sealing materials	Standards	
Mineral oil	HLP	NBR	DIN 51524	
Bio-degradable	- insoluble in water	HETG	NBR	
		HEES	FKM	VDMA 24568
	- soluble in water	HEPG	FKM	VDMA 24568
	Flame-resistant	- water-free	HFDD, HFDR	FKM
	- containing water	HFAS	NBR	DIN 24320
		HFAE	NBR	
		HFC	NBR	VDMA 24317



Important information on hydraulic fluids!

- For more information and data on the use of other hydraulic fluids, please refer to data sheet 90220 or contact us.
- **Flame-resistant - containing water:** Due to possible chemical reactions with materials or surface coatings of machine and system components, the service life with these hydraulic fluids may be less than expected. Filter materials made of filter

paper P... (cellulose) may not be used, filter elements with filter materials made of glass fiber (HydroClean H...XL or wire mesh G) have to be used instead.

- **Bio-degradable:** If filter materials made of filter paper are used, the filter life may be shorter than expected due to material incompatibility of and swelling.

12/32 10TDN0040-1000; 10TD2000/2500 | RE 51454

Characteristic curves: H3XL

(measured with mineral oil HLP46 according to DIN 51524 at T = 40 °C) [104 °F]

Spec. weight: < 0.9 kg/dm³

Δp-Q characteristic curves for complete filter

recommended initial Δp for design = 0.5 bar [7.25 psi]

Selection of the perfect filter is made possible by our online "Bosch Rexroth FilterSelect" design software.

Oil viscosity:

- 140 mm²/s [649 SUS]
- · - 68 mm²/s [315 SUS]
- - - 30 mm²/s [142 SUS]

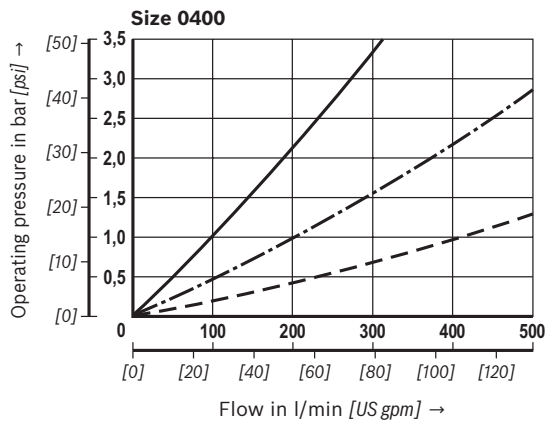
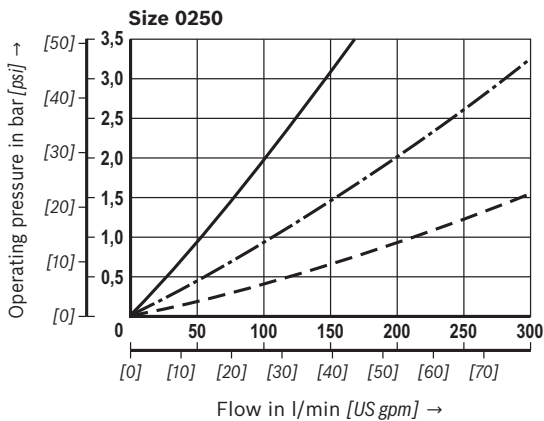
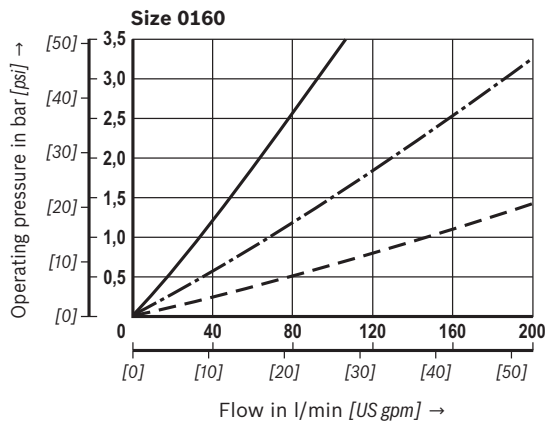
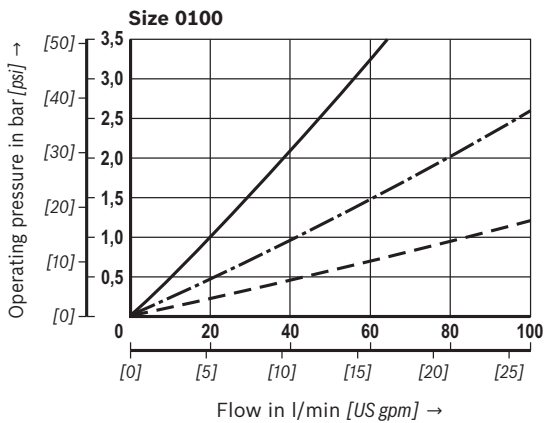
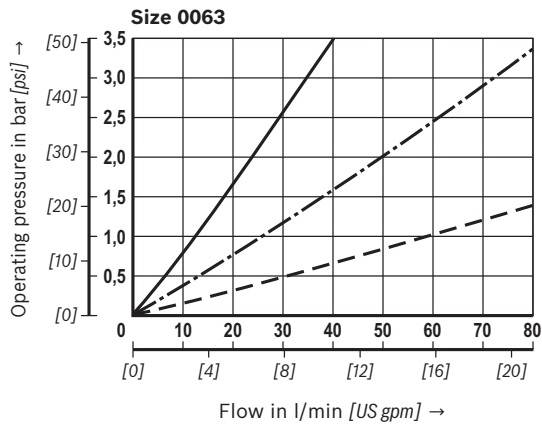
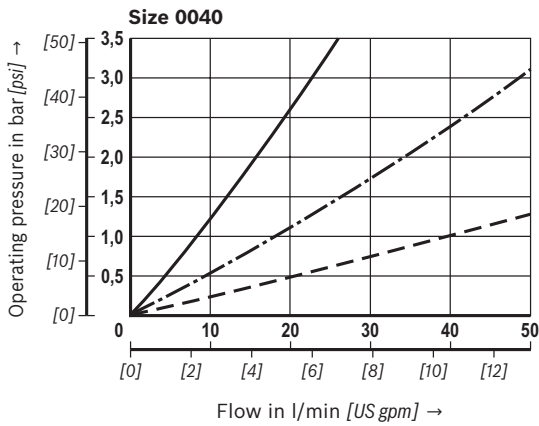

Bosch Rexroth AG, RE 51454, edition: 2013-12

Characteristic curves: H3XL

(measured with mineral oil HLP46 according to DIN 51524 at T = 40 °C) [104 °F])

Spec. weight: < 0.9 kg/dm³

Δp-Q characteristic curves for complete filter

recommended initial Δp for design = 0.5 bar [7.25 psi]

Selection of the perfect filter is made possible by our online "Bosch Rexroth FilterSelect" design software.

Oil viscosity:

- 140 mm²/s [649 SUS]
- · - 68 mm²/s [315 SUS]
- - - 30 mm²/s [142 SUS]

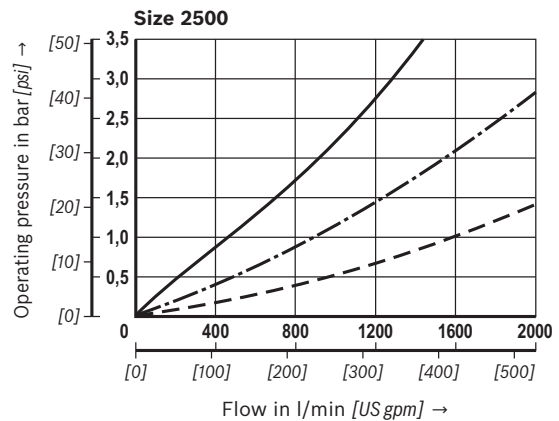
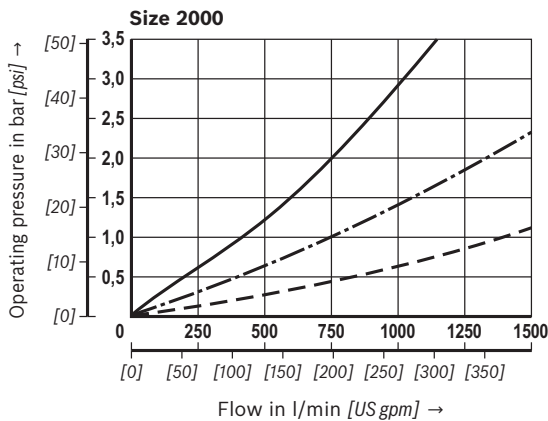
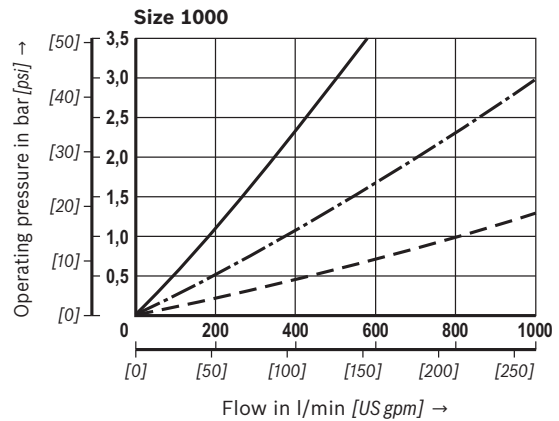
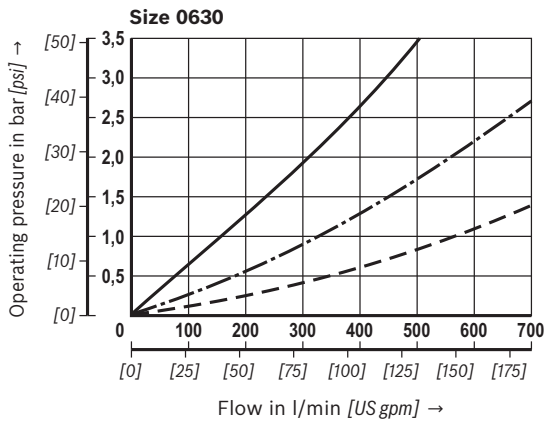

14/32 10TDN0040-1000; 10TD2000/2500 | RE 51454

Characteristic curves: H6XL

(measured with mineral oil HLP46 according to DIN 51524 at T = 40 °C) [104 °F]

Spec. weight: < 0.9 kg/dm³

Δp-Q characteristic curves for complete filter

recommended initial Δp for design = 0.5 bar [7.25 psi]

Selection of the perfect filter is made possible by our online "Bosch Rexroth FilterSelect" design software.

Oil viscosity:

- 140 mm²/s [649 SUS]
- · - 68 mm²/s [315 SUS]
- - - 30 mm²/s [142 SUS]

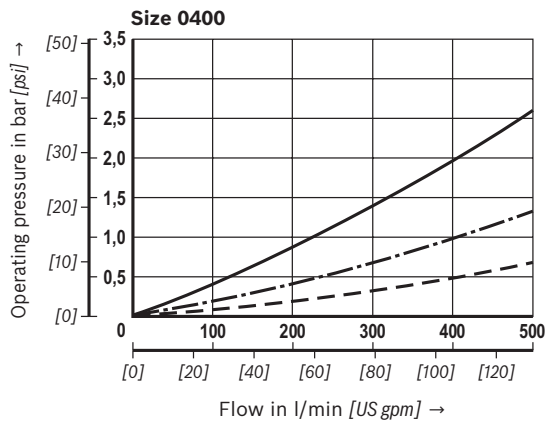
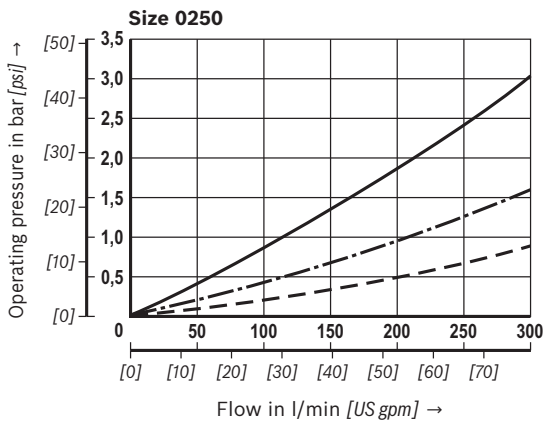
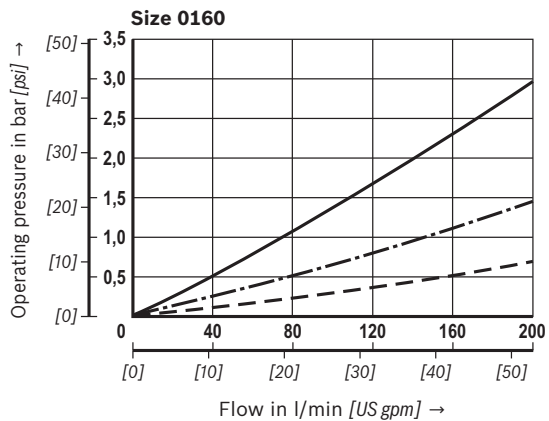
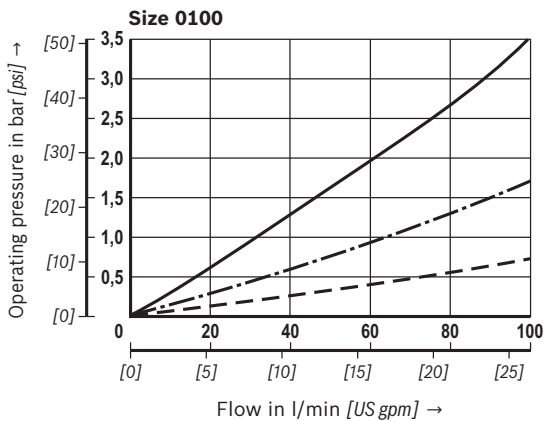
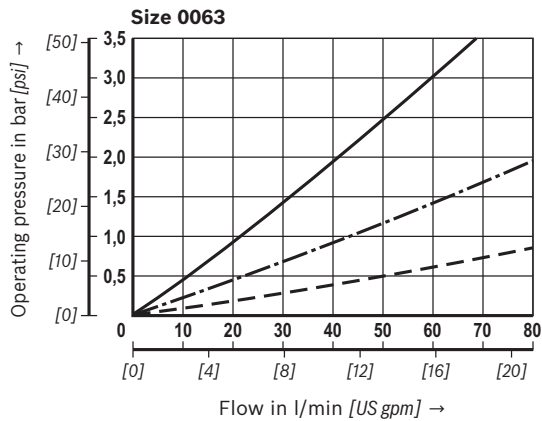
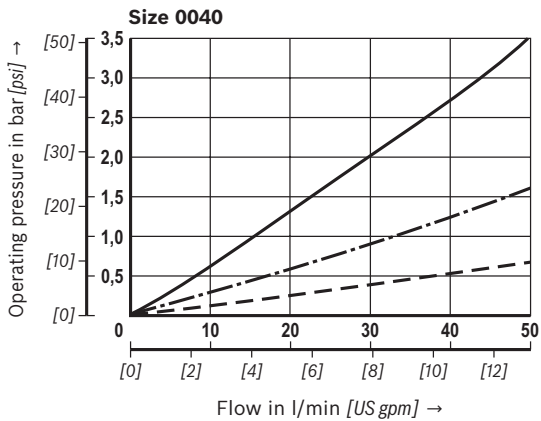

Bosch Rexroth AG, RE 51454, edition: 2013-12

Characteristic curves: H6XL

(measured with mineral oil HLP46 according to DIN 51524 at T = 40 °C) [104 °F]

Spec. weight: < 0.9 kg/dm³

Δp-Q characteristic curves for complete filter

recommended initial Δp for design = 0.5 bar [7.25 psi]

Selection of the perfect filter is made possible by our online "Bosch Rexroth FilterSelect" design software.

Oil viscosity:

- 140 mm²/s [649 SUS]
- · - 68 mm²/s [315 SUS]
- - - 30 mm²/s [142 SUS]

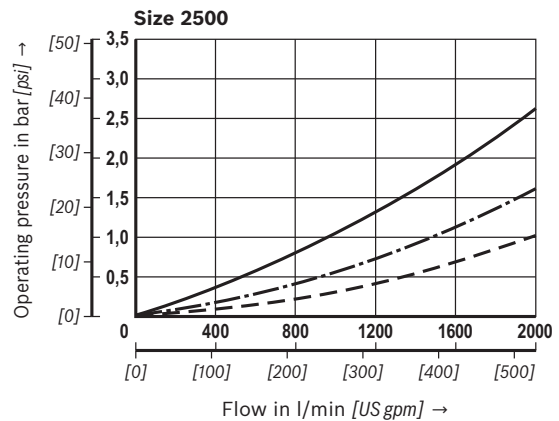
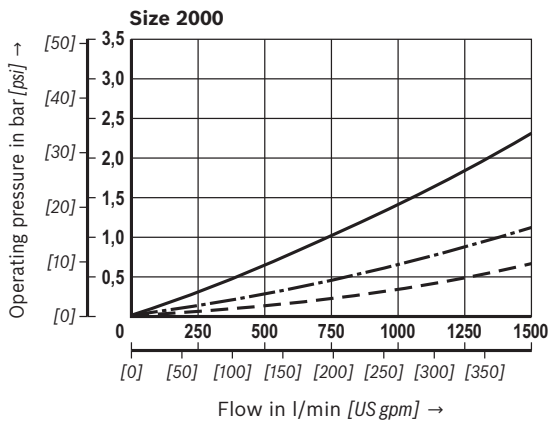
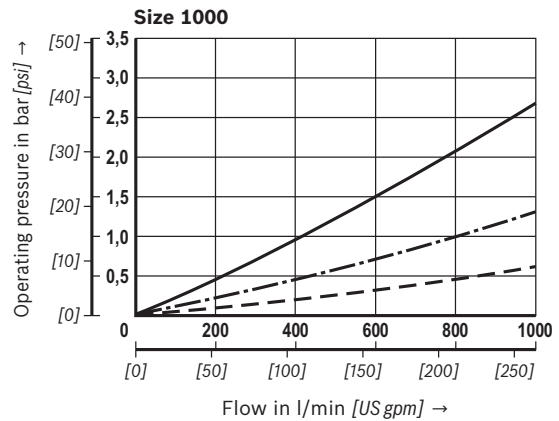
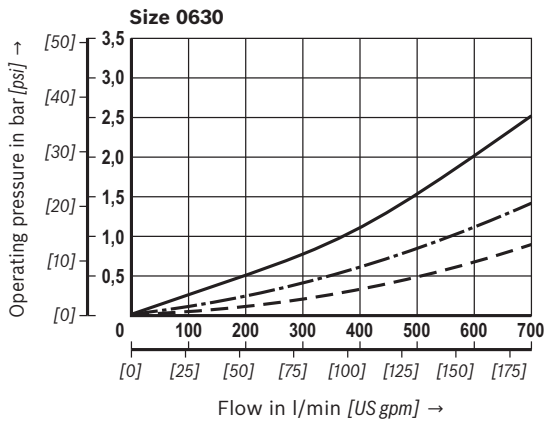

16/32 10TDN0040-1000; 10TD2000/2500 | RE 51454

Characteristic curves: H10XL

(measured with mineral oil HLP46 according to DIN 51524 at T = 40 °C) [104 °F]

Spec. weight: < 0.9 kg/dm³

Δp-Q characteristic curves for complete filter

recommended initial Δp for design = 0.5 bar [7.25 psi]

Selection of the perfect filter is made possible by our online "Bosch Rexroth FilterSelect" design software.

Oil viscosity:

- 140 mm²/s [649 SUS]
- · - 68 mm²/s [315 SUS]
- - - 30 mm²/s [142 SUS]

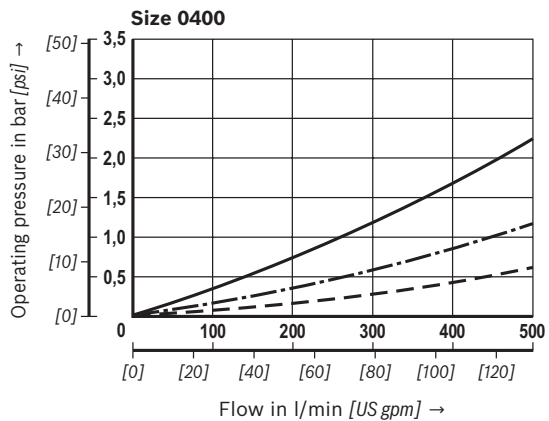
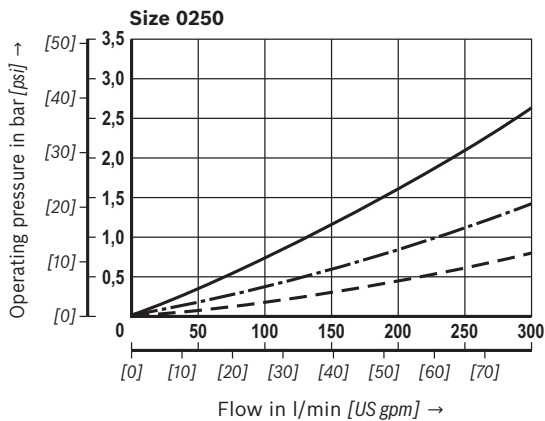
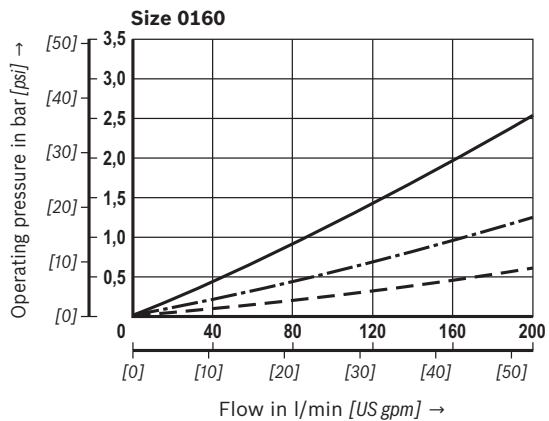
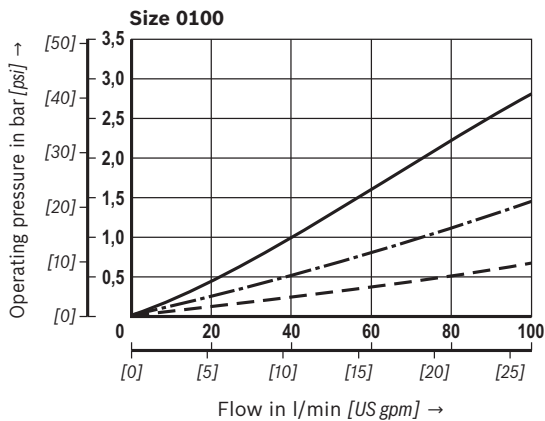
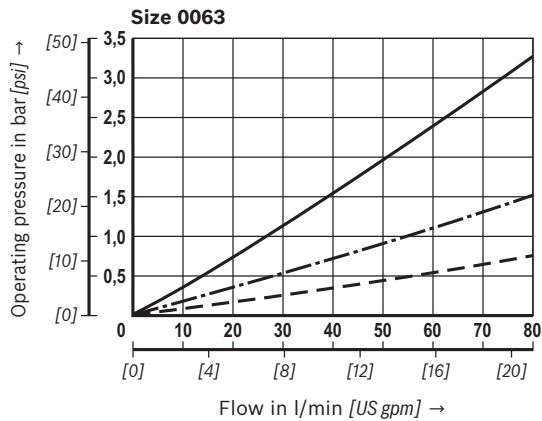
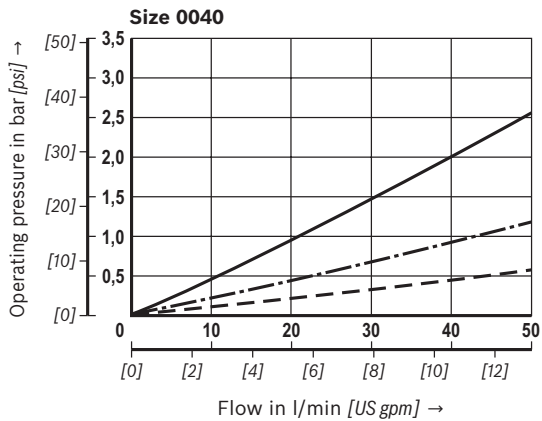

Bosch Rexroth AG, RE 51454, edition: 2013-12

Characteristic curves: H10XL

(measured with mineral oil HLP46 according to DIN 51524 at T = 40 °C) [104 °F]

Spec. weight: < 0.9 kg/dm³

Δp-Q characteristic curves for complete filter

recommended initial Δp for design = 0.5 bar [7.25 psi]

Selection of the perfect filter is made possible by our online "Bosch Rexroth FilterSelect" design software.

Oil viscosity:

- 140 mm²/s [649 SUS]
- · - 68 mm²/s [315 SUS]
- - - 30 mm²/s [142 SUS]

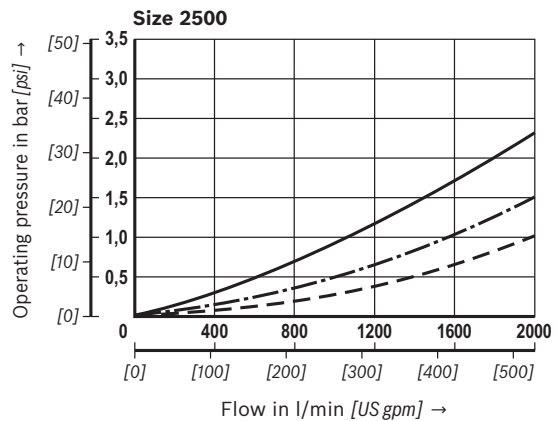
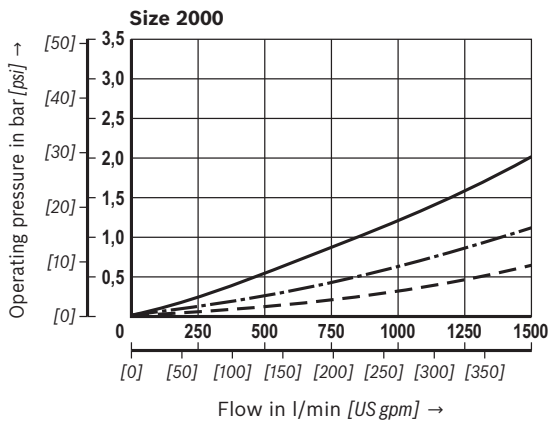
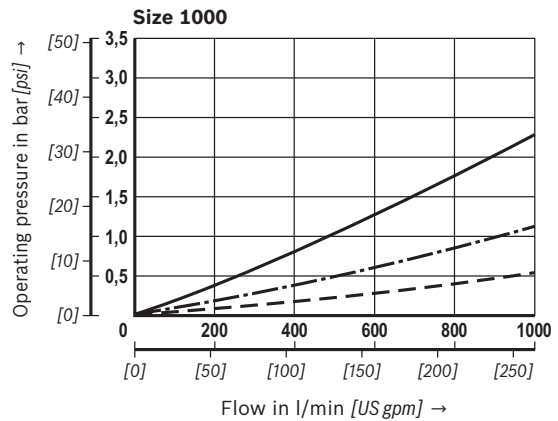
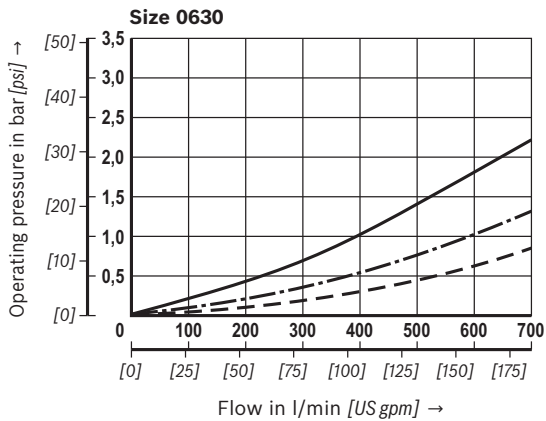

18/32 10TDN0040-1000; 10TD2000/2500 | RE 51454

Characteristic curves: H20XL

(measured with mineral oil HLP46 according to DIN 51524 at T = 40 °C) [104 °F]

Spec. weight: < 0.9 kg/dm³

Δp-Q characteristic curves for complete filter

recommended initial Δp for design = 0.5 bar [7.25 psi]

Selection of the perfect filter is made possible by our online "Bosch Rexroth FilterSelect" design software.

Oil viscosity:

- 140 mm²/s [649 SUS]
- · - 68 mm²/s [315 SUS]
- - - 30 mm²/s [142 SUS]

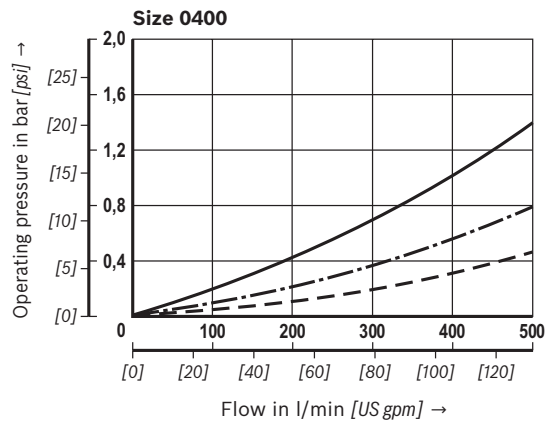
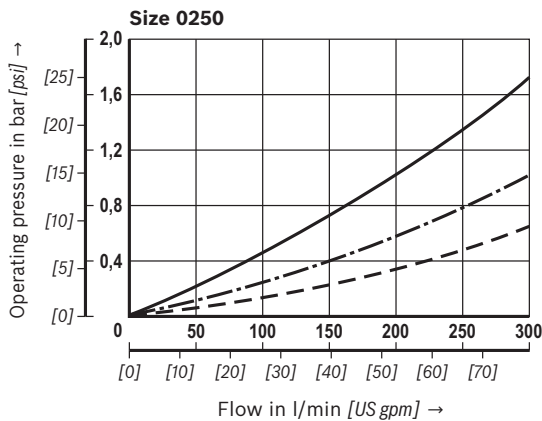
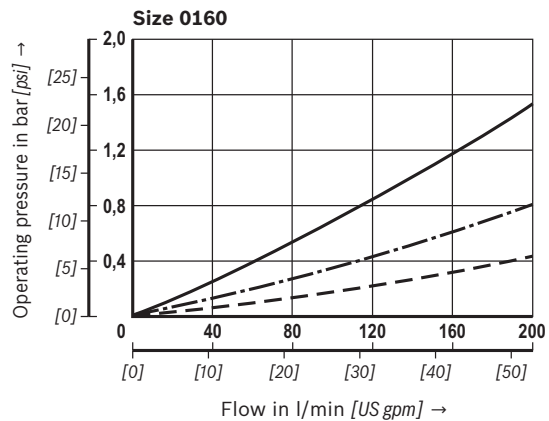
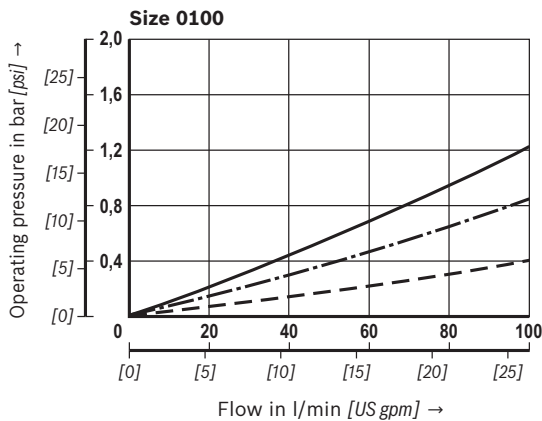
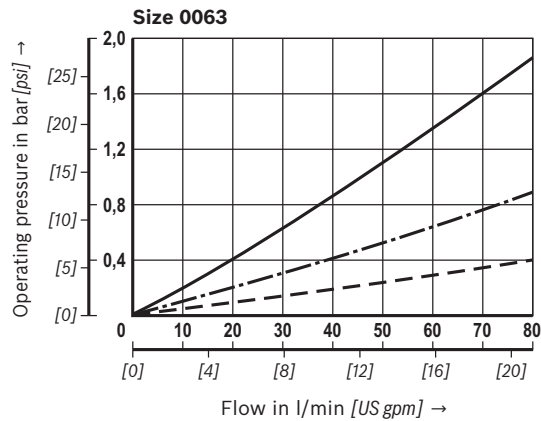
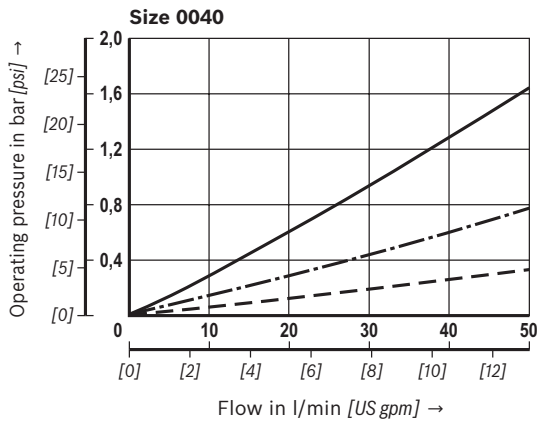

Bosch Rexroth AG, RE 51454, edition: 2013-12

Characteristic curves: H20XL

(measured with mineral oil HLP46 according to DIN 51524 at T = 40 °C) [104 °F])

Spec. weight: < 0.9 kg/dm³

Δp -Q characteristic curves for complete filter

recommended initial Δp for design = 0.5 bar [7.25 psi]

Selection of the perfect filter is made possible by our online "Bosch Rexroth FilterSelect" design software.

Oil viscosity:

- 140 mm²/s [649 SUS]
- · - 68 mm²/s [315 SUS]
- - - 30 mm²/s [142 SUS]

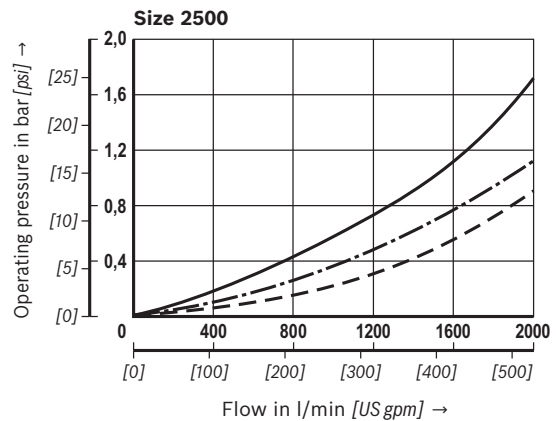
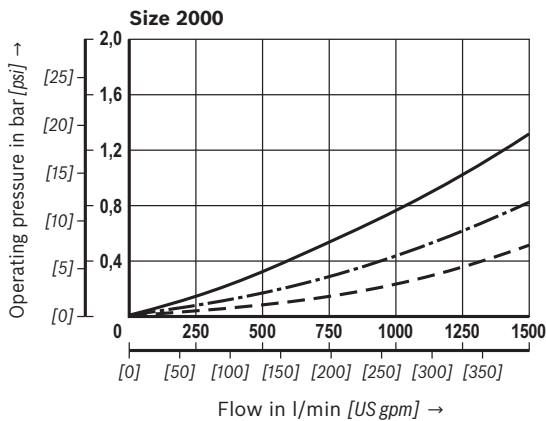
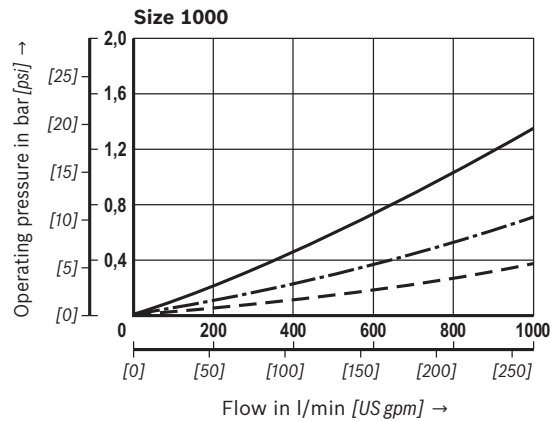
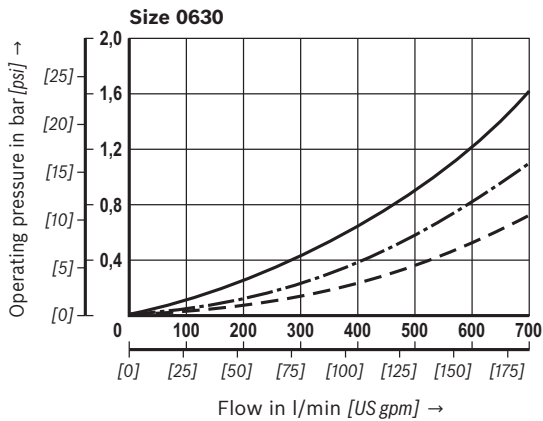

20/32 10TDN0040-1000; 10TD2000/2500 | RE 51454

Dimensions: 10TDN0040, 0063, 0100
(dimensions in mm [inch])

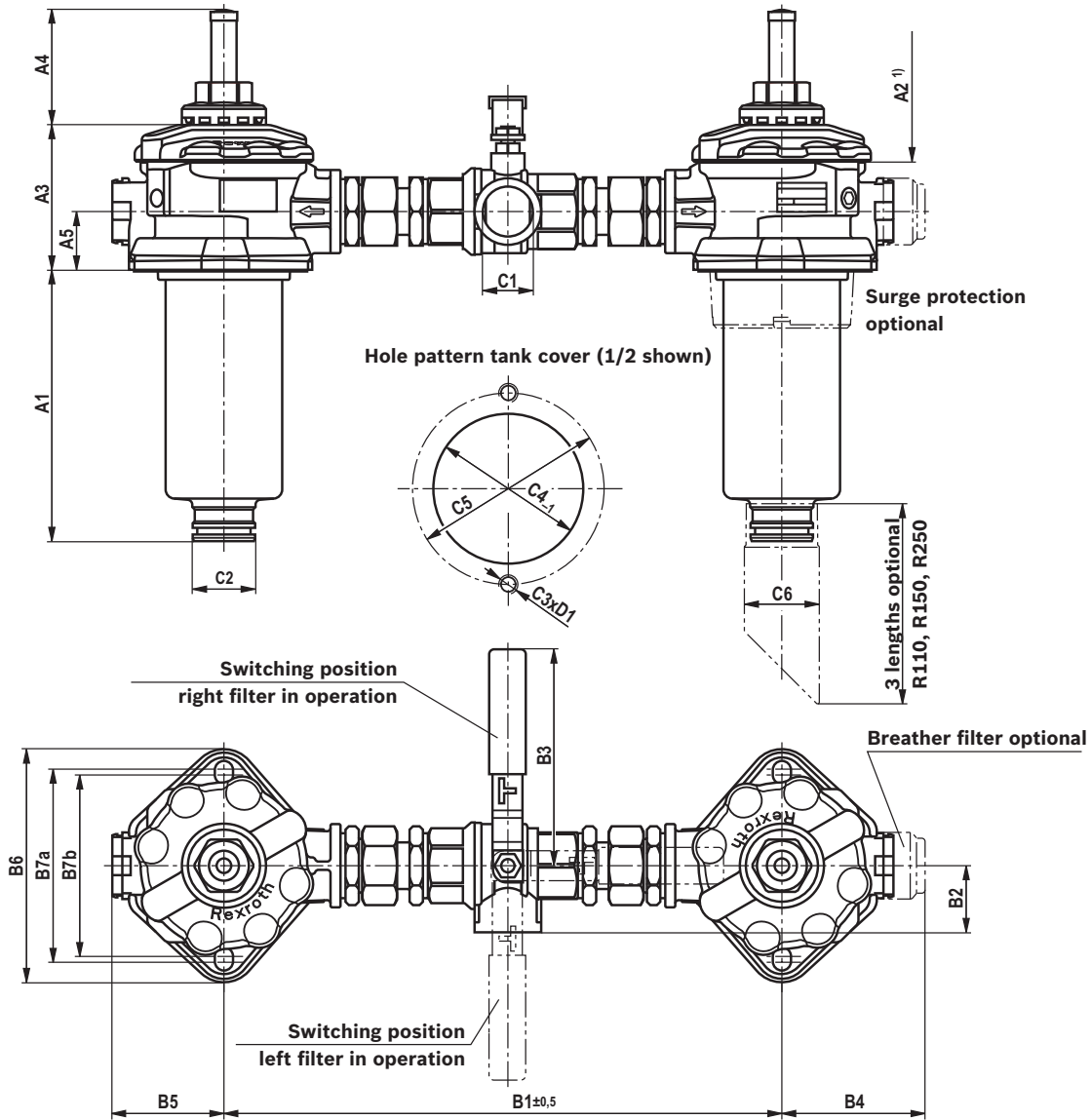

¹⁾ Observe the servicing height plus the length of the outlet pipe, if applicable

Type	A1	A2	A3	A4	A5	B1	B2	B3	B4
10TDN0040	103 [4.06]	100 [3.94]	87 [3.43]	69 [2.72]	35 [1.38]	335 [13.19]	40 [1.57]	129.5 [5.10]	86 [3.39]
10TDN0063	163 [6.42]	160 [6.30]							
10TDN0100	253 [9.96]	250 [9.84]							

Type	B5	B6	B7a	B7b	C1 connection Standard	U... (SAE J1926)	C2	C3	ØC4	ØC5	ØC6	D1
10TDN0040	67 [2.64]	140 [5.51]	116 [4.57]	109 [4.29]	G 1	SAE 16 1 5/16-12 UN-2B	25.31 [1.00]	M10	90 [3.54]	115 [4.53]	45 [1.77]	12 ¹²
10TDN0063												
10TDN0100												

Bosch Rexroth AG, RE 51454, edition: 2013-12

Dimensions: 10TDN0160, 0250
(dimensions in mm [inch])

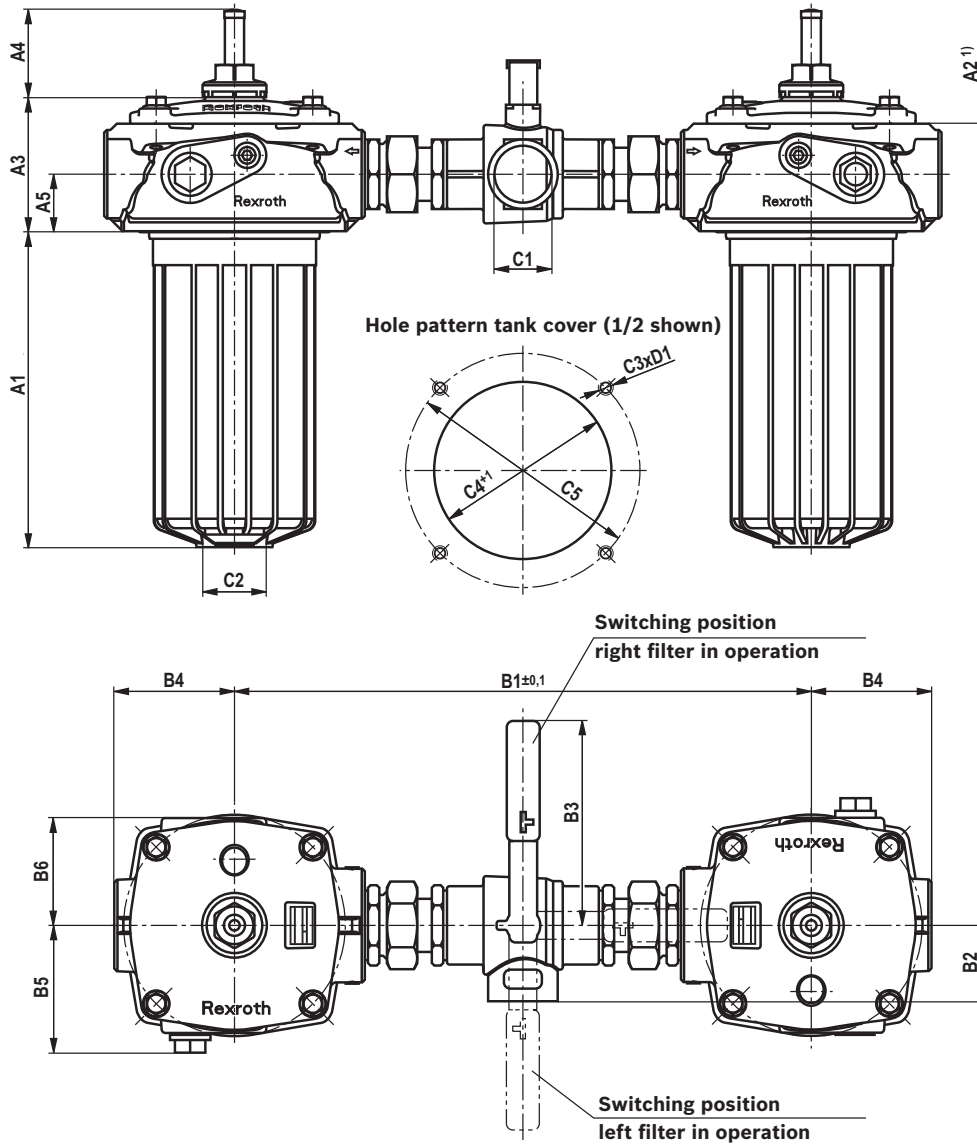

¹⁾ Observe the servicing height plus the length of the outlet pipe, if applicable

Type	A1	A2	A3	A4	A5	B1	B2	B3
10TDN0160	160 [6.30]	160 [6.30]	106 [4.17]	69 [2.72]	45 [1.77]	435 [17.13]	54 [2.13]	161.5 [6.36]
10TDN0250	250 [9.84]	250 [9.84]				456 [17.95]	60 [2.36]	159 [6.26]

Type	B4	B5	B6	C1 connection		C2	C3	ØC4	ØC5	D1
				Standard	U... (SAE J1926)					
10TDN0160	95 [3.74]	100.5 [3.96]	85 [3.35]	G 1 1/2	SAE 24	25 [0.98]	M10	140 [5.51]	185 [7.28]	12 ⁺²
10TDN0250					1 7/8-12 UN-2B					

RE 51454, edition: 2013-12, Bosch Rexroth AG

22/32 10TDN0040-1000; 10TD2000/2500 | RE 51454

Dimensions: 10TDN0400, 0630

(dimensions in mm [inch])

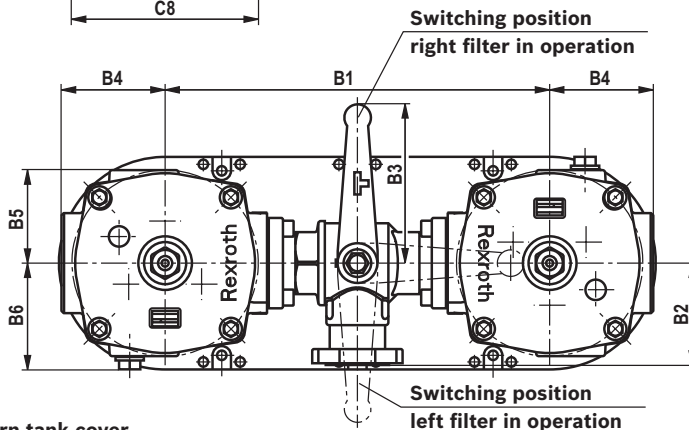
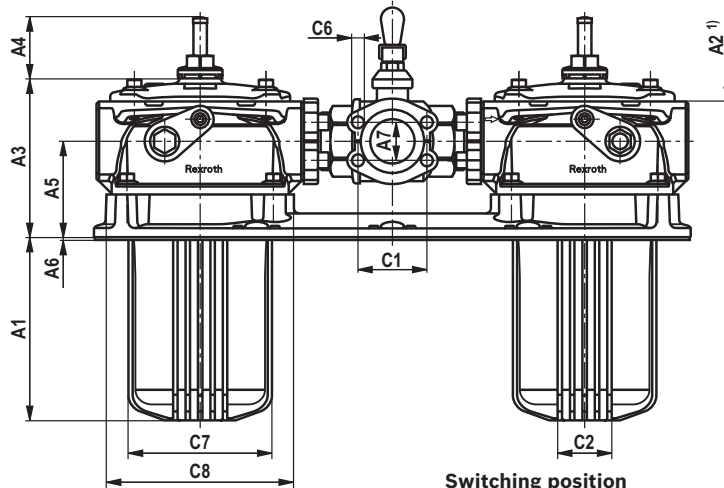

Hole pattern tank cover with installation plate

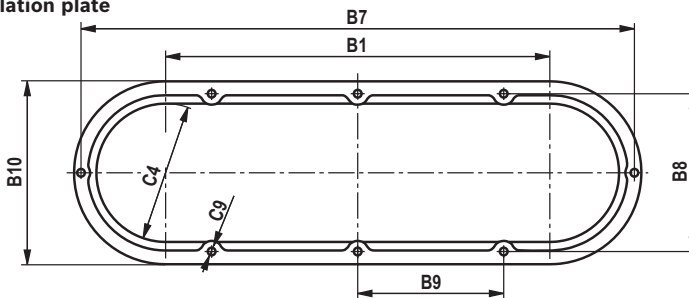

Hole pattern tank cover (1/2 shown) without installation plate

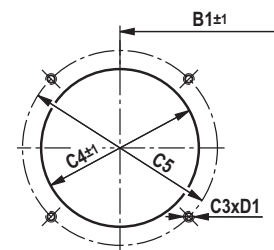

¹⁾ Observe the servicing height plus the length of the outlet pipe, if applicable

Type	A1	A2	A3	A4	A5	A6	A7	B1	B2	B3	B4	B5	B6
TDN0400	210 [8.27]	335 [13.19]	176	69	105	3	49.8	434 [17.09]	135	173	117	105	120
TDN0630	360 [14.17]	485 [19.09]	[6.93]	[2.72]	[4.13]	[0.12]	[1.96]	500 [19.69]	[5.31]	[6.81]	[4.61]	[4.13]	[4.72]

Type	B7	B8	B9	B10	C1 connection U... Standard		C2	C3	ØC4	ØC5	ØC6	ØC7	ØC8	C9	D1	
10TDN0400	720	205	190	238	SAE 2 1/2" - 3000 psi		-	G2	M10	178 [70.1]	220 [8.66]	M12	162 [6.38]	202 [7.95]	M10	12 ⁺²
10TDN0630	[28.35]	[8.07]	[7.48]	[9.37]												

Bosch Rexroth AG, RE 51454, edition: 2013-12

Dimensions: 10TDN1000, 10TD2000, 10TD2500
(dimensions in mm [inch])

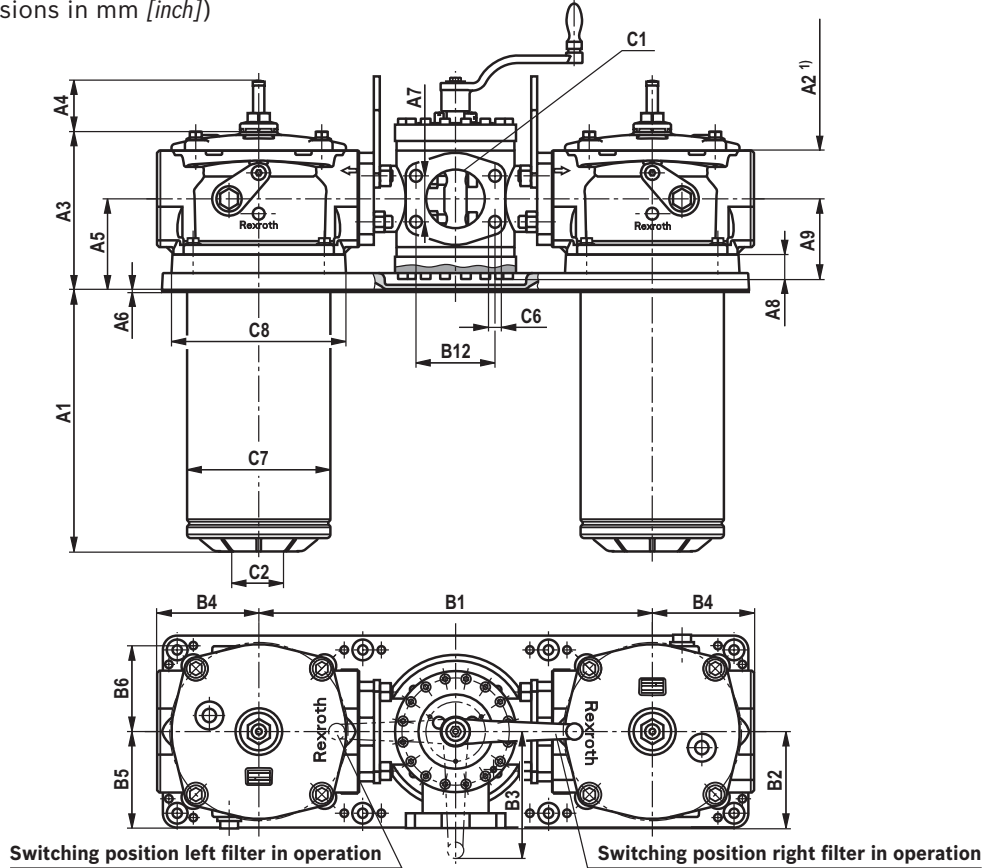

Hole pattern tank cover with installation plate

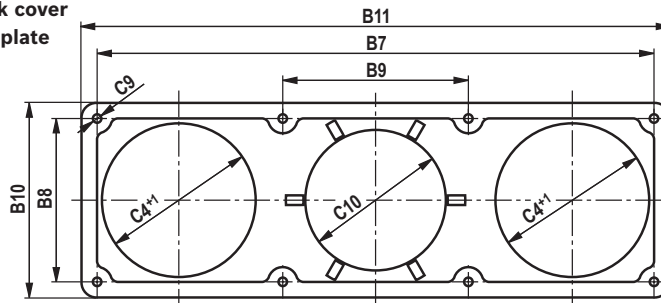

Hole pattern tank cover (1/2 shown) without installation plate

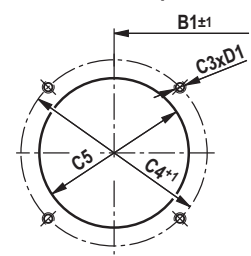

¹⁾ Observe the servicing height plus the length of the outlet pipe, if applicable

Type 10...	A1	A2	A3	A4	A5	A6	A7	A8	A9	B1	B2	B3	B4	B5	B6	B7	B8
TDN1000	352.5 [13.87]	530 [20.87]	165 [6.50]	69 [2.72]	122.5 [4.81]	3 [0.12]	61.9 [2.44]	10 [0.39]	32.5 [1.27]	530 [20.87]	130 [5.12]	160 [6.30]	137 [5.39]	130.5 [5.14]	115 [4.53]	750 [29.53]	220 [8.66]
TD2000	749 [29.49]	880 [34.65]															
TD2500	983 [38.70]	1130 [44.49]															

Type 10...	B9	B10	B11	B12	C1 connection U...		C2	C3	ØC4	ØC5	ØC6	ØC7	ØC8	C9	ØC10	D1
					Standard	(SAE J1926)										
TDN1000	250 [9.84]	262 [10.31]	792 [31.18]	106.4 [4.19]	SAE 3"		G3	M10	202 [7.95]	250 [9.84]	M16	193 [7.60]	235 [9.25]	M10	195 [7.68]	12 ⁺²
TD2000					3000 psi											
TD2500																

24/32 10TDN0040-1000; 10TD2000/2500 | RE 51454

Maintenance indicator (dimensions in mm [inch])

**Electronic switching element
with round plug-in connection M12x1, 4-pole**

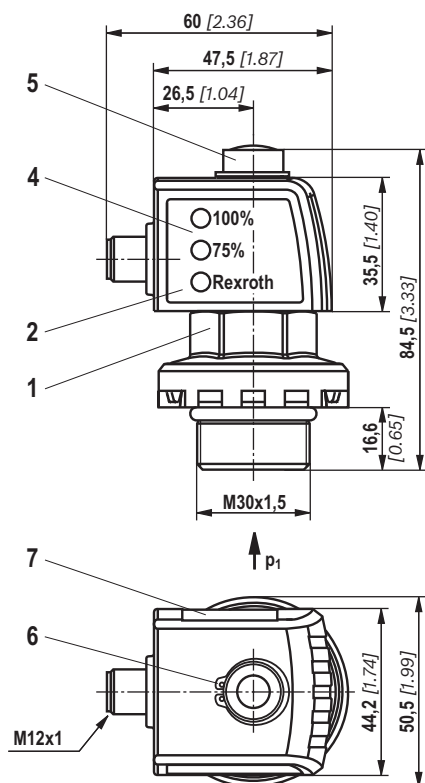

**Electronic switching element
with rectangular plug-in connection EN 175301-803**

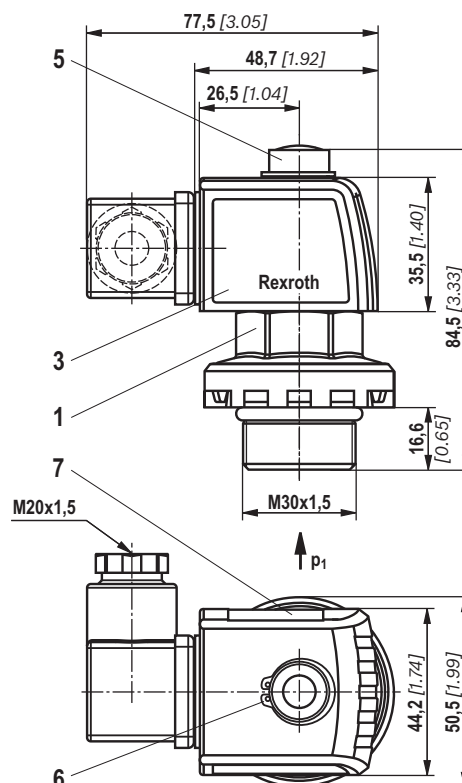

- 1 Mechanical optical maintenance indicator;
max. tightening torque $M_{A \max} = 50 \text{ Nm}$ [36.88 lb-ft]
Tightening torque for back pressure indicator in PA6.6
 $M_{A \max} = 35 \text{ Nm}$ [25.82 lb-ft]
- 2 Switching element with locking ring for electrical maintenance indicator (rotatable by 360°); plug-in connection M12x1, 4-pole
- 3 Switching element with locking ring for electrical maintenance indicator (rotatable by 360°); plug-in connection EN175301-803
- 4 Housing with three LEDs: 24 V =
Green: Stand-by
Yellow: Switching point 75 %
Red: Switching point 100 %
- 5 Optical indicator with memory function
- 6 Locking ring DIN 471-16x1, Material no. **R900003923**
- 7 Name plate

Notice!

Representation contains mechanical optical maintenance indicator (1) and electronic switching element (2) (3).
Switching elements with increased switching power upon request. If an electronic switching element with signal suppression up to 30 °C [86 °F] is used (WE-2SPSU-M12X1, **R928028411**), the aluminum version of the mechanical-optical maintenance indicator **must** be used. In the filter type key, these maintenance indicators are referred to as "V2,2", "V1,5" or "V0,8".
Also refer to the chapter "Spare parts and accessories".
The temperature-controlled signal processing does not work with mechanical-optical maintenance indicators made of polyamide.

Bosch Rexroth AG, RE 51454, edition: 2013-12

RE 51454 | 10TDN0040-1000; 10TD2000/2500 25/32

Ordering code

Spare parts

Filter element

01	02	03	04	05	06
1.			- A00	- 0	-

01	Design	1.
----	--------	----

Size

02	TDN... (filter element according to DIN 24550)	0040 0063 0100 0160 0250 0400 0630 1000
	TD... (filter elements according to Bosch Rexroth standard)	2000 2500

Filter rating in μm

03	Nominal	Paper, not cleanable	P10 P25
	Nominal	Stainless steel wire mesh, cleanable	G10 G25 G40 G60 G100
	Absolute (ISO 16889); $\beta_{x(c)} \geq 200$	Non-woven glass fiber media, not cleanable	H3XL H6XL H10XL H20XL
	Absolute (ISO 16889); $\beta_{x(c)} \geq 200$	Water-absorbing, not cleanable	AS6 AS10 AS20

Pressure differential

04	Maximum admissible pressure differential of the filter element 30 bar [435 psi]	A00
----	---	-----

Bypass valve

05	Without bypass valve	0
----	----------------------	---

Seal

06	NBR seal	M
	FKM seal	V

Order example:

1.0100 H3XL -A00-0-M

For detailed information on Rexroth filter elements please refer to data sheet 51420.

RE 51454, edition: 2013-12, **Bosch Rexroth AG**

26/32 10TDN0040-1000; 10TD2000/2500 | RE 51454

Ordering code Spare parts

Filter element

Preferred program

Replacement elements

Filter element type	Filter material/material no.			
	H3XL	H6XL	H10XL	H20XL
1.0040 ...A00-0-M	R928005835	R928005836	R928005837	R928005838
1.0063 ...A00-0-M	R928005853	R928005854	R928005855	R928005856
1.0100 ...A00-0-M	R928005871	R928005872	R928005873	R928005874
1.0160 ...A00-0-M	R928005889	R928005890	R928005891	R928005892
1.0250 ...A00-0-M	R928005925	R928005926	R928005927	R928005928
1.0400 ...A00-0-M	R928005961	R928005962	R928005963	R928005964
1.0630 ...A00-0-M	R928005997	R928005998	R928005999	R928006000
1.1000 ...A00-0-M	R928006033	R928006034	R928006035	R928006036
1.2000 ...A00-0-M	R928041312	R928048158	R928040797	R928041313
1.2500 ...A00-0-M	R928041314	R928046806	R928040800	R928041315

Bosch Rexroth AG, RE 51454, edition: 2013-12

RE 51454 | 10TDN0040-1000; 10TD2000/2500 27/32

Ordering code Spare parts

Mechanical optical maintenance indicator

01	02	03	04	05	06	07
W	O	-	S01	-	-	10

01	Maintenance indicator	W
----	-----------------------	---

02	Mechanical optical indicator	O
----	------------------------------	---

Design

03	Back pressure M30x1.5	S01
----	-----------------------	-----

Switching pressure

04	0.8 bar [12 psi] (not possible with plastic version)	0.8
	1.5 bar [22 psi] (not possible with plastic version)	1.5
	2.2 bar [32 psi]	2.2

Seal

05	NBR seal	M
	FKM seal	V

Max. nominal pressure

06	10 bar [145 psi]	10
----	------------------	----

Housing material

07	Plastic only 2.2 bar [32 psi] possible	PA
	Aluminum	No code

Mechanical optical maintenance indicator

Material no.	Description
R928038773	WO-S01-0,8-M-10
R928038772	WO-S01-0,8-V-10
R928038776	WO-S01-1,5-M-10
R928038774	WO-S01-1,5-V-10
R901025310	WO-S01-2,2-M-10
R901066232	WO-S01-2,2-V-10
R928038771	WO-S01-2,2-M-10-PA
R928038769	WO-S01-2,2-V-10-PA

Pressure gauge ¹⁾

Material no.	Description
R928019224	M010 0-6 bar [0-87psi]

¹⁾ If the manometer option is chosen, the maximum pressure rating for the 10TDN filter is reduced from 10 bar [145 psi] to 6 bar [87 psi].

Breathing filter element

(only for 10TDN0040-0100) incl. plastic cap

Material no.	Description
R928019705	71.001 P5-S00-0-0

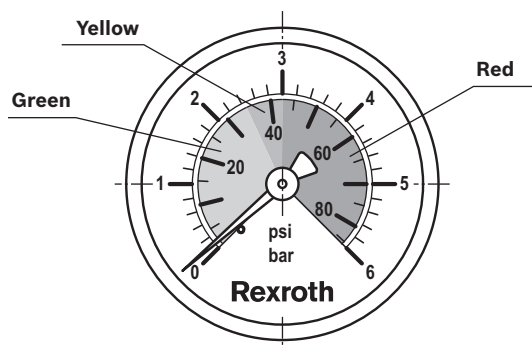

RE 51454, edition: 2013-12, Bosch Rexroth AG

28/32 10TDN0040-1000; 10TD2000/2500 | RE 51454

Ordering code Spare parts

Seal kit

01	02	03	04	05
D	10TD	-	1X	/ -

01	Seal kit	D
----	----------	---

02	Series	10TD
----	--------	------

Size

03	0040-0100	N0040-0100
	0160-0250	N0160-0250
	0400-0630	N0400-0630
	1000	N1000
	2000-2500	2000-2500

04	Component series 10 ... 19 (10 ... 19: Unchanged installation and connection dimensions)	1X
----	--	----

Seal

05	NBR seal	M
	FKM seal	V

Seal kit

Material no.	Description
R928051474	D10TDN0040-0100-1X/-M
R928051475	D10TDN0160-0250-1X/-M
R928051476	D10TDN0400-0630-1X/-M
R928051478	D10TDN1000-1X/-M
R928051479	D10TD2000-2500-1X/-M
R928051993	D10TDN0040-0100-1X/-V
R928051994	D10TDN0160-0250-1X/-V
R928051995	D10TDN0400-0630-1X/-V
R928051996	D10TDN1000-1X/-V
R928051997	D10TD2000-2500-1X/-V

Bosch Rexroth AG, RE 51454, edition: 2013-12

Assembly, commissioning, maintenance

Assembly

The max. operating pressure of the system must not exceed the max. admissible operating pressure of the filter (see name plate).

If the manometer option is chosen, the maximum pressure rating for the 10TDN filter is reduced from 10 bar [145 psi] to 6 bar [87 psi].

Before the assembly, the hole pattern of the tank must be compared to the dimensions from the "Dimensions" chapter.

It is strongly recommended to secure drain pipes longer than 400 mm with an inside tank mount bracket in order to avoid vibrations due to fluid flow in the tank. Additionally, it is necessary for maintenance work to ensure the filter bowl and the outlet pipe are pulled out of the filter head together.

During assembly of the filter (see also chapter "Tightening torques"), the flow direction (direction arrows) and the required servicing height of the filter element (see chapter "Dimensions") are to be considered. With frame sizes 1000 - 2500, the lifting eyes can be used as assembly aid.

Perfect functioning is only guaranteed in the installation position filter bowl vertically downwards and ON the tank. The maintenance indicator must be arranged so it is easily viewed in operation.

Remove the plastic plugs in the filter inlet and outlet. Ensure that the system is assembled without tension stress.

The optional electronic maintenance indicator is connected via the electronic switching element with 1 or 2 switching points, which is attached to the mechanical optical maintenance indicator and held by means of the locking ring.

Commissioning

Commission the system.

Switch the filter into the operating position; to do so, switch the switching lever to one of the two end positions. The filter in use is identified by the flow symbol on the changeover handle.

Notice!

There is no bleed function provided at the filter.

Maintenance

- ▶ If at operating temperature, the red indicator pin reaches out of the mechanical optical maintenance indicator and/or if the switching process in the electronic switching element is triggered, the filter element is contaminated and needs to be replaced or cleaned respectively.
- ▶ The material number of the corresponding replacement filter element is indicated on the name plate of the complete filter. It must comply with the material number on the filter element.
- ▶ Move the switching lever to the opposite end position in order to switch to the clean filter side. Observe the flow direction symbol on the switching lever and/or the switch-over.
- ▶ Unscrew the filter cover and/or loosen the screws and remove the filter over upwards.

Notice!

Note that elements with lower filtration ratings may take slightly longer to discharge the residual oil. If there is still residual oil in the filter bowl, the fluid has to be collected in a separate tank.

- ▶ Remove the filter element together with the filter bowl. From frame size 0160, the filter bowls are equipped with removal brackets.
- ▶ Remove the filter element from the spigot in the filter bowl by rotating it slightly.
- ▶ Clean the filter components, if necessary.
- ▶ Check the seals at filter cover and filter bowl for damage and replace them, if necessary. For suitable seal kits refer to chapter "Spare parts".
- ▶ Filter elements made of wire mesh can be cleaned. The efficiency of the cleaning depends on the type of dirt and the amount of the pressure differential before the filter element exchange. If the pressure differential after the filter element exchange exceeds 150 % of the value of a brand-new filter element, the filter element made of wire mesh (G...) also needs to be replaced. For detailed cleaning instructions refer to data sheet 51420.
- ▶ Install the new or cleaned filter element on the spigot again by slightly rotating it.
- ▶ The filter is to be assembled in reverse order.
- ▶ The torque specifications ("Tightening torques" chapter) are to be observed.
- ▶ During the filter element exchange, the breathing filter element should be exchanged manually if equipped (only with size 0040-0100)

30/32 10TDN0040-1000; 10TD2000/2500 | RE 51454

Assembly, commissioning, maintenance

WARNINGS!

- ▶ Assemble and disassemble only with depressurized system! For the filter element exchange refer to "Maintenance".
 - ▶ Tank is pressurized!
 - ▶ Maintenance only by trained specialists.
 - ▶ Do not operate the switching lever during the filter element exchange.
 - ▶ Do not exchange the maintenance indicator while the filter is under pressure!
- ▶ Functional and safety warranty only applicable when using genuine Bosch Rexroth spare parts!
 - ▶ Warranty becomes void if the delivered item is changed by the ordering party or third parties or improperly mounted, installed, maintained, repaired, used or exposed to environmental condition that do not comply with the installation conditions.

Tightening torques

(dimensions in mm [inch])

Tank mounting without installation plate

Series 10TD...	N0040	N0063	N0100	N0160	N0250	N0400	N0630	N1000	2000	2500
Tank mounting screw	M10 x 30			M10 x 25			M12 x 25			
Quantity	4			8						
Recommended property class of screw	8.8									
Tightening torque with $\mu_{\text{total}} = 0.14$	21 Nm \pm 10 % [16 lb-ft \pm 10%]						37 Nm \pm 10 % [27 lb-ft \pm 10%]			

Tank mounting with installation plate

Series 10TD...	N0040	N0063	N0100	N0160	N0250	N0400	N0630	N1000	2000	2500
Installation plate screw (hexagon socket head cap screw)	-					M10 x 20		M10 x 25		
Quantity	-					8				
Recommended property class of screw	-					8.8				
Tightening torque with $\mu_{\text{total}} = 0.14$	-					21 Nm \pm 10 % [16 lb-ft \pm 10%]				

Filter cover

Series 10TD...	N0040	N0063	N0100	N0160	N0250	N0400	N0630	N1000	2000	2500
Filter cover screw	-			M10		M12				
Quantity	-			4						
Recommended property class of screw	-			8.8						
Tightening torque with $\mu_{\text{total}} = 0.14$	Manually to the stop 20 Nm \pm 10 % ¹⁾ [15 lb-ft \pm 10%]			21 Nm \pm 10 % [16 lb-ft \pm 10%]		37 Nm \pm 10 % [27 lb-ft \pm 10%]				

Maintenance indicator

Series 10TD...	N0040	N0063	N0100	N0160	N0250	N0400	N0630	N1000	2000	2500
Tightening torque maintenance indicator, mechanical optical, aluminum, V...					50 Nm \pm 5 Nm [37 lb-ft \pm 4 lb-ft]					
Tightening torque maintenance indicator, mechanical optical, PA, P2,2					35 Nm \pm 3 Nm [26 lb-ft \pm 3 lb-ft]					
Tightening torque cubic connector screw switching element EN-175301-803					M3/0.5 Nm [0.4 lb-ft]					

¹⁾ Re-tighten using an open-end wrench (SW19), if necessary

Bosch Rexroth AG, RE 51454, edition: 2013-12

Directives and standardization

Classification according to the Pressure Equipment Directive

The return filters for hydraulic applications according to 51454 are pressure holding equipment according to article 1, section 2.1.4 of the Pressure Equipment Directive 97/23/EC (PED). However, based on the exception in

article 1, section 3.6 of the PEG, hydraulic filters are exempt from the PED if they are not classified higher than category I (guideline 1/19). They do not receive a CE mark.

Use in explosive areas according to directive 94/9/EC (ATEX)

The duplex tank mounted return line filters according to 51454 are not equipment or components in the sense of directive 94/9/EC and are not provided with a CE mark. It has been proven with the ignition risk analysis that these return filters do not have own ignition sources acc. to DIN EN 13463-1:2009. According to DIN EN 60079-11:2012, the electronic maintenance indicators WE-1SP-M12x1 and WE-1SP-EN175301-803 are simple, electronic operating equipment not having an own voltage source. This simple, electronic operating equipment may - according to DIN EN 60079-14:2008 - in intrinsically safe electric circuits (Ex ib) be used in systems without marking and certification.

The duplex tank mounted return line filters and the electronic maintenance indicators described here can be used for the following explosive areas:

	Zone suitability	
	1	2
Gas		
Dust	21	22

Complete filter with mech./opt. maintenance indicator			
Use/assignment		Gas 2G	Dust 2D
Assignment		Ex II 2G c IIB TX	Ex II 2D c IIB TX
Conductivity of the medium	pS/m min		300
Dust accumulation	max	-	0.5 mm

Electronic switching element in the intrinsically safe electric circuit			
Use/assignment		Gas 2G	Dust 2D
Assignment		Ex II 2G Ex ib IIB T4 Gb	Ex II 2D Ex ib IIIC T100 °C Db
Adm. intrinsically safe electric circuits		Ex ib IIC, Ex ic IIC	Ex ib IIIC
Technical data		Values only for intrinsically safe electric circuit	
Switching voltage	Ui max	150 V AC/DC	
Switching current	Ii max	1.0 A	
Switching power	Pi max	1.3 W T4 T _{max} 40 °C	750 mW T _{max} 40 °C
		1.0 W T4 T _{max} 80 °C	550 mW T _{max} 100 °C
Surface temperature ¹⁾	max	-	100 °C
Inner capacity	Ci	Neglectable	
Inner inductivity	Li	Neglectable	
Dust accumulation	max	-	0.5 mm

¹⁾ The temperature depends on the temperature of the medium in the filter and must not exceed the value specified here.

32/32 10TDN0040-1000; 10TD2000/2500 | RE 51454

Directives and standardization

Possible circuit according to DIN EN 60079-14

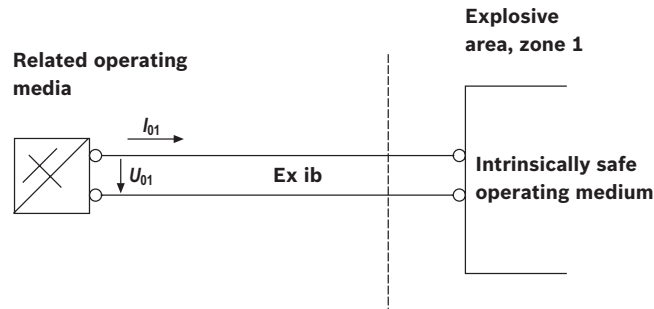

⚠ WARNING!

- ▶ Explosion hazard due to high temperature!
The surface temperature of the filter depends on the temperature of the medium in the hydraulic circuit and must not exceed the value specified here. Measures are to be taken so that in the explosive area, the max. admissible ignition temperature is not exceeded.
- ▶ When using the duplex tank mounted return line filters according to 51454 in explosive areas, appropriate equipotential bonding has to be ensured. The filter is preferably to be earthed via the mounting screws.

It has to be noted in this connection that paintings and oxidic protective layers are not electrically conductive.

- ▶ Maintenance only by specialists, instruction by the machine end-user acc. to DIRECTIVE 1999/92/EC appendix II, section 1.1.
- ▶ During filter element exchanges, the packaging material is to be removed from the replacement element outside the explosive area.
- ▶ Functional and safety warranty only applicable when using genuine Rexroth spare parts.

© This document, as well as the data, specifications and other information set forth in it, are the exclusive property of Bosch Rexroth AG. It may not be reproduced or given to third parties without its consent.

The data specified above only serve to describe the product. No statements concerning a certain condition or suitability for a certain application can be derived from our information. The information given does not release the user from the obligation of own judgment and verification. It must be remembered that our products are subject to a natural process of wear and aging.

Bosch Rexroth AG, RE 51454, edition: 2013-12