

Proportional flow control valve, without position control

RE 29219/04.07
Replaces: 08.05

Type 3(2)FREX

Nominal size (NG) 6, 10
Unit series 1X
Maximum working pressure 250 bar
Nominal flow rate Q_{nom} 7.5...60 l/min



List of contents

Contents	Page
Features	1
Ordering data	2
Preferred types	2
Symbols	3
Function, sectional diagram	4
Accessories	5
Technical data	6
External trigger electronics	7 to 9
Characteristic curves	10 to 13
Unit dimensions	14 and 15

Features

- Directly controlled flow control valves NG6 and NG10
- 2- or 3-way function is determined by how the hydraulic ports are assigned (residual flow runs through port P, 3rd way). Symbol "NO" (normally open) can only be implemented as a 2-way function
- Adjustable by means of the solenoid current, see Characteristic Curve, Technical Data and the selected valve electronics
- Solenoid version $I_{max} = 2.5 A$
- For subplate attachment, mounting hole configuration NG6 to ISO 4401-03-02-0-05, NG10 to ISO 4401-05-04-0-05
- Subplates as per catalog sheet, RE 45053 for NG6, RE 45055 for NG10 (order separately)
- Plug-in connector to DIN 43650-AM2 included in scope of delivery
- External trigger electronics with ramps and valve calibration in the following versions/designs (order separately)
 - Plug, setpoint 0...+10 V or 4...20 mA, RE 30264
 - Module, setpoint 0...+10 V, RE 30222
 - Europe card format, setpoint 0...+10 V, RE 30109

Symbols

For external trigger electronics

2-way, normally open

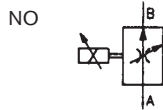

3-way, normally closed

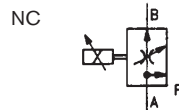

3-way, normally closed with manual auxiliary override

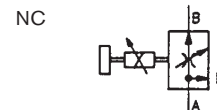

General

Flow control valves are directly actuated throttle valves with integrated pressure compensator.

Direction of flow

"3-way design" proportional flow control valves that are normally closed may be employed either as 2-way or 3-way flow control valves.

3-way flow control valve

A: Supply
B: Discharge
P: Residual flow, capacity up to 250 bar, or tank
T: Closed

2-way flow control valve

A: Supply
B: Discharge
P: } Closed
T: }

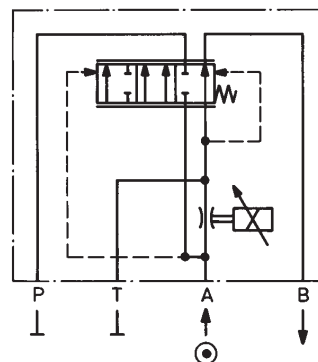
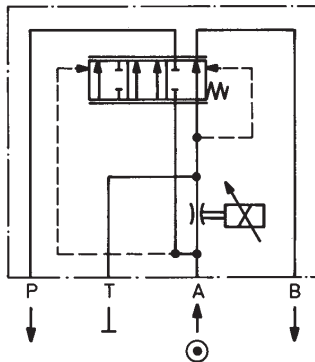

Note

Flow control valves with a normally open basic position may only be used as 2-way valves.

Function, sectional diagram

General

Type 3(2)FREX proportional flow control valves without position control are available in nominal sizes 6 and 10. They are actuated by means of a proportional solenoid. Hysteresis is < 5%, the valve amplifier electronics are available in various designs.

The symbol "NO", normally open, can only be used as a 2-way flow control valve (type 2FREX).

The symbol "NC", normally closed, can be used as a 3 or a 2-way flow control valve.

The design of the valve body is such that, in the 3-way version, the residual flow runs through port P.

In the 2-way version, the flow runs from A to B (P and T are closed).

Basic principle

To adjust the oil flow rate, a setpoint is set in the trigger electronics. Based on this setpoint, the electronics control the solenoid coil with regulated PWM (pulse-width-modulated) current. The current is modulated with a dither, ensuring low hysteresis. The proportional solenoid converts the current to a mechanical force, with which an armature plunger acts on a spool to push against the spring. This then achieves a position that conforms to the characteristic curve of the spring. The valve opening is determined by the metering edges on the spool, and the integrated pressure compensator compares the pressure drop by means of a 4- or 8-bar measuring spring.

The pressure compensator with measuring spring regulates the pressure before the throttling edge according to the simplified formula:

"Load pressure plus force of measuring spring".

In this way, the pressure drop over the metering edge is maintained at a constant level.



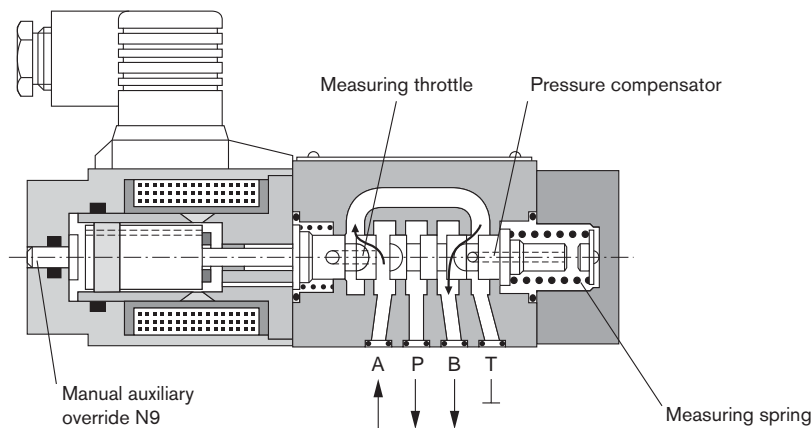



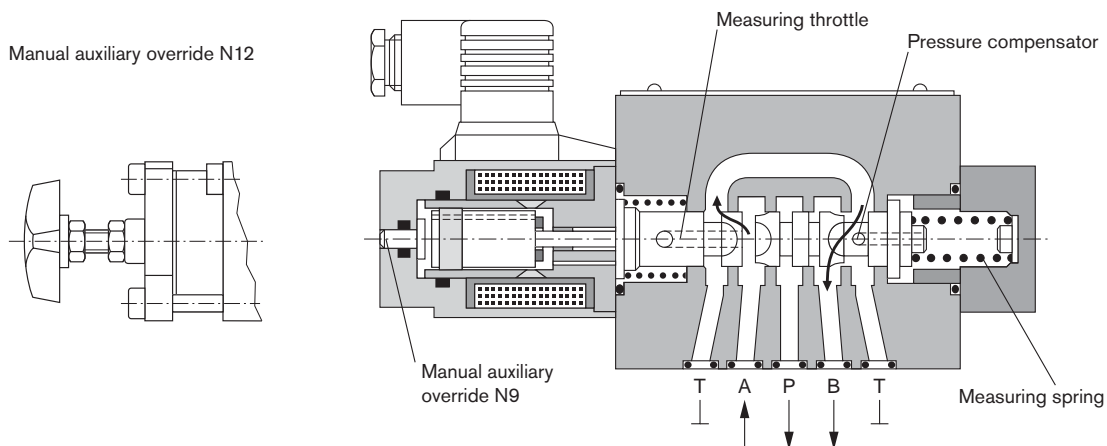

NG6



NG10

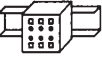

Accessories

Type		Material Number
(4x)  ISO 4762-M5x30-10.9	Cheese-head bolts NG6	2 910 151 166
(4x)  ISO 4762-M6x35-10.9	Cheese-head bolts NG10	2 910 151 207
Plug  	VT-SSPA1-525-20/V0 (2.5 A)	RE 30264 0 811 405 143
	VT-SSPA1-525-20/V0/I (2.5 A)	0 811 405 145
Module  	VT-MSPA1-525-10/V0 (2.5 A)	RE 30222 0 811 405 127
Europe card  	VT-VSPA1-525-10/V0/RTP (2.5 A)	RE 30109 0 811 405 079
Plug-in connector 	Plug-in connector 2P+PE (M16x1.5) included in scope of delivery, see also RE 08008	

Testing and service equipment

Test box type VT-PE-TB1, see RE 30063
Current measuring adapter type VT-PA-5, see RE 30073

Technical data

General

Construction	Spool-type valve with integrated pressure compensator	
Actuation	Proportional solenoid without position control, manual auxiliary override, external amplifier	
Connection type	Subplate, mounting hole configuration NG6 (ISO 4401-03-02-0-05), NG10 (ISO 4401-05-04-0-05)	
Mounting position	Optional	
Ambient temperature range	°C	-20...+50
Weight	NG6 kg	2.0 (2.2 with manual auxiliary override)
	NG10 kg	5.8 (6.0 with manual auxiliary override)
Vibration resistance, test condition	Max. 25 g, shaken in 3 dimensions (24 h)	

Hydraulic (measured with HLP 46, $\vartheta_{oil} = 40\text{°C} \pm 5\text{°C}$)

Pressure fluid	Hydraulic oil to DIN 51524...535, other fluids after prior consultation				
Viscosity range	recommended mm ² /s	20...100			
	max. permitted mm ² /s	10...800			
Pressure fluid temperature range	°C	-20...+80			
Maximum permitted degree of contamination of pressure fluid Purity class to ISO 4406 (c)	Class 18/16/13 ¹⁾				
Direction of flow, see symbol	NG6			NG10	
Nominal flow rate Q_B with closed-loop control	l/min	7.5	15	35	60 70
Supply flow rate $Q_{A\max}$	l/min	30	(NO)	40	65 (NO)
Minimum pressure drop $p_A > p_B$	bar	10	10	22	22 22
Max. working pressure	bar	Port A, B: 250 Port T: Closed Port P: Closed or residual flow 250 bar			

Electrical

Cyclic duration factor	%	100
Degree of protection	IP 65 to DIN 40050 and IEC 14434/5	
Solenoid connection	Unit plug DIN 43650/ISO 4400, M16x1.5 (2P+PE)	
Valve with solenoid type	A	2.5
Max. solenoid current I_{\max}	A	2.5
Coil resistance R_{20}	Ω	3
Max. power consumption at 100% load and operating temperature	VA	30

Static/Dynamic²⁾

Hysteresis	%	≤ 5 from $q_{v\max}$
Range of inversion	%	≤ 3 from $q_{v\max}$
Manufacturing tolerance	%	≤ 20 from $q_{v\max}$
Response time 100% signal change	ms	On < 70
Correction time on max. load change (pressure compensator)		NG6 ≤ 30 NG10 ≤ 45

¹⁾ The purity classes stated for the components must be complied with in hydraulic systems. Effective filtration prevents problems and also extends the service life of components. For a selection of filters, see catalog sheets RE 50070, RE 50076 and RE 50081.

²⁾ All characteristic values ascertained using amplifier 0 811 405 079 for the 2.5 A solenoid.

Valve with external trigger electronics (plug, RE 30264)

Circuit diagram/pin assignment

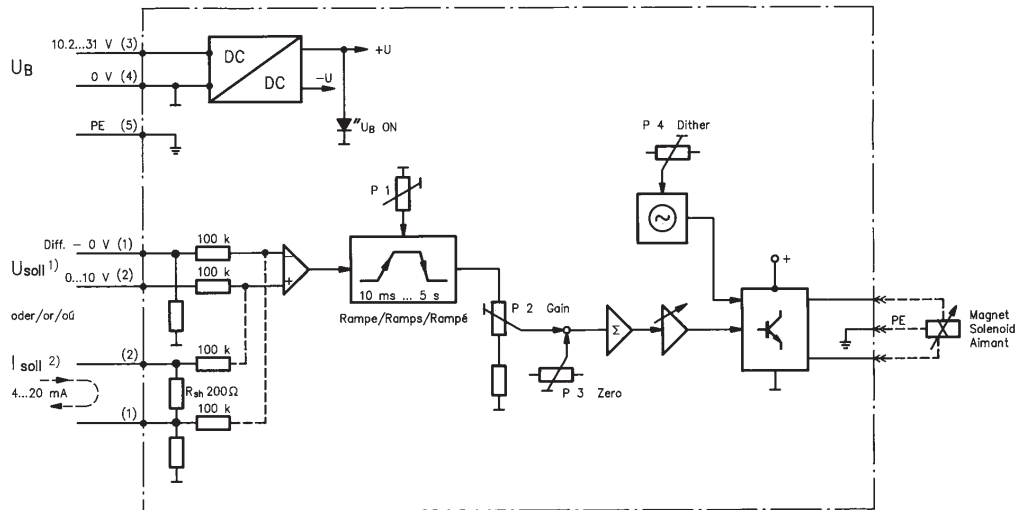

1) Version with 0...+10 V signal

2) Version with 4...20 mA signal

Connection/calibration

- P1 – Ramp time
- P2 – Sensitivity
- P3 – Zero
- P4 – Dither frequency
- St1 – Terminal
- LED – U_B display

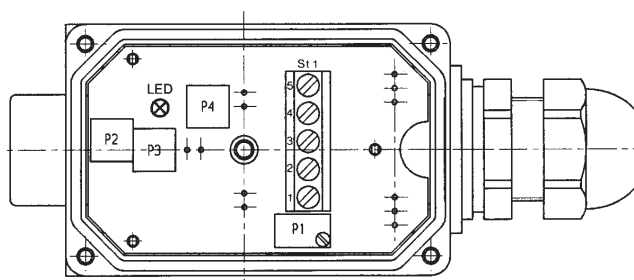

Valve with external trigger electronics (module, RE 30222)

Circuit diagram/pin assignment

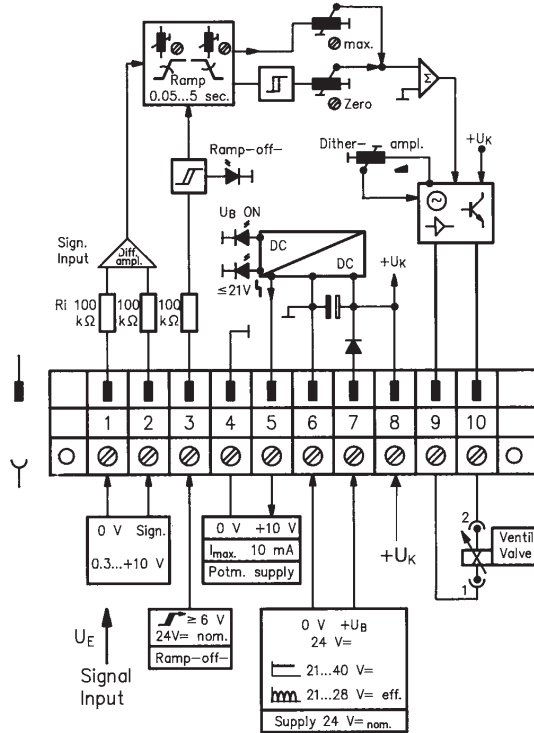

Front view/calibration

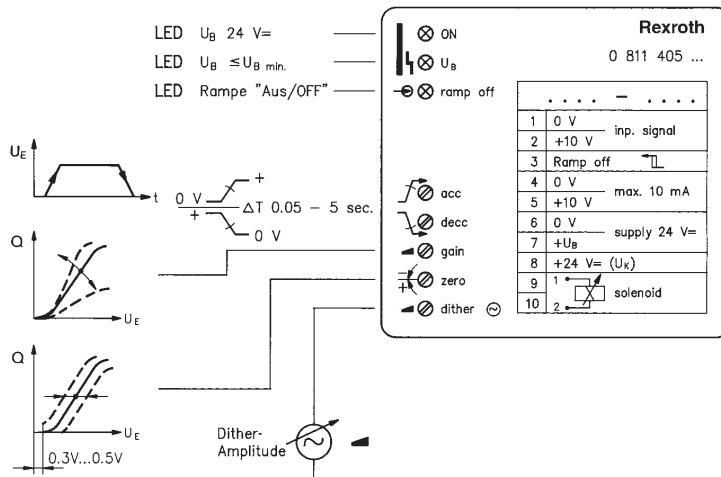

Characteristic curves NG6 (measured with HLP 46, $\vartheta_{oil} = 40^\circ\text{C} \pm 5^\circ\text{C}$)

$Q_{nom} = 7.5/15/35 \text{ l/min}$

Basic position open "NO"
(2-way version)

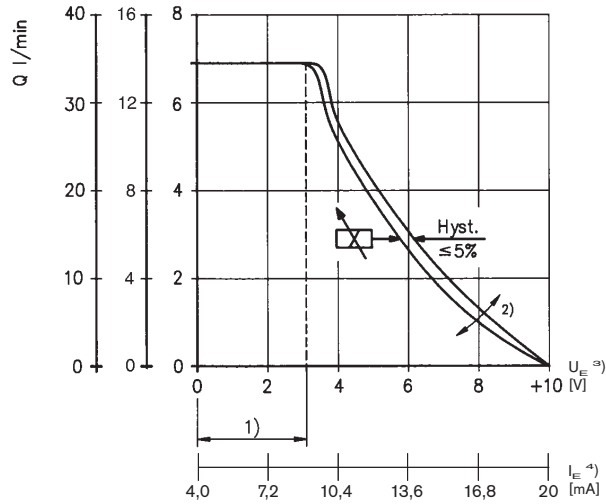

$Q_{nom} = 7.5/15/35 \text{ l/min}$

Basic position closed "NC"
(3- or 2-way version)

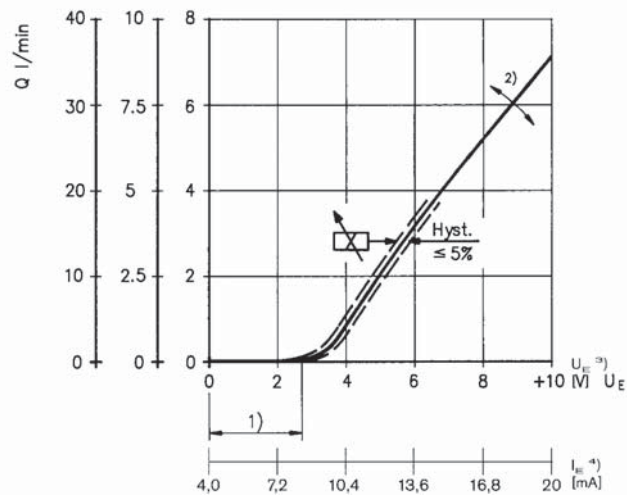

Valve amplifier

- 1) Zero adjustment
- 2) Sensitivity adjustment
- 3) Version: $U_E = 0 \dots +10 \text{ V}$
- 4) Version: $I_E = 4 \dots 20 \text{ mA}$

Characteristic curves NG6 (measured with HLP 46, $\vartheta_{oil} = 40^\circ\text{C} \pm 5^\circ\text{C}$)

2-way version

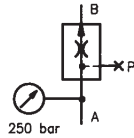

$Q_{nom} = 7.5/15/35 \text{ l/min}$

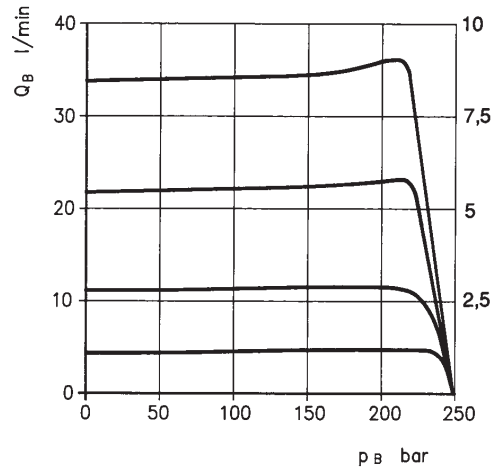

3-way version

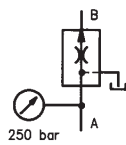

$Q_{nom} = 7.5/15/35 \text{ l/min}$

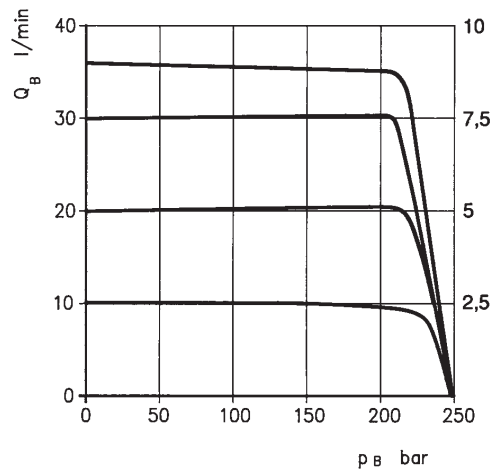

Residual flow "A-P"
(pressure drop)

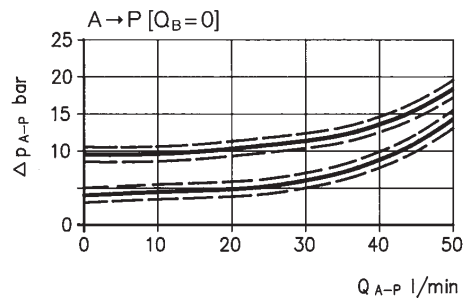
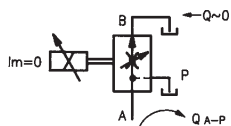

Characteristic curves NG10 (measured with HLP 46, $\vartheta_{oil} = 40^\circ\text{C} \pm 5^\circ\text{C}$)

$Q_{nom} = 60 (70) \text{ l/min}$

Basic position open "NO"
(2-way version)

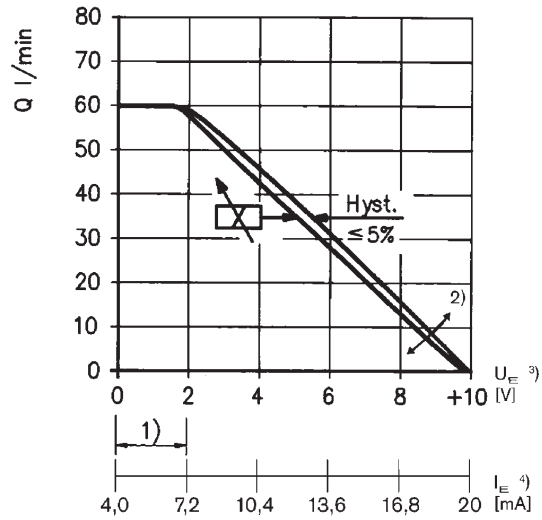

$Q_{nom} = 60 \text{ l/min}$

Basic position closed "NC"
(3- or 2-way version)

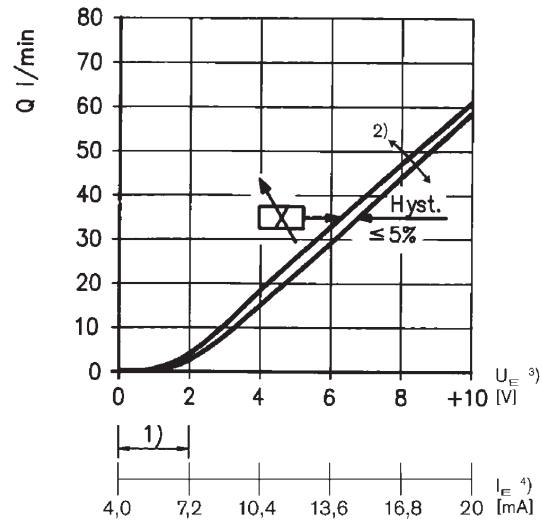

Valve amplifier

- 1) Zero adjustment
- 2) Sensitivity adjustment
- 3) Version: $U_E = 0 \dots +10 \text{ V}$
- 4) Version: $I_E = 4 \dots 20 \text{ mA}$

Characteristic curves NG10 (measured with HLP 46, $\vartheta_{oil} = 40^\circ\text{C} \pm 5^\circ\text{C}$)

2-way version

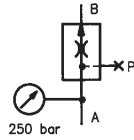

$Q_{nom} = 60 (70) \text{ l/min}$

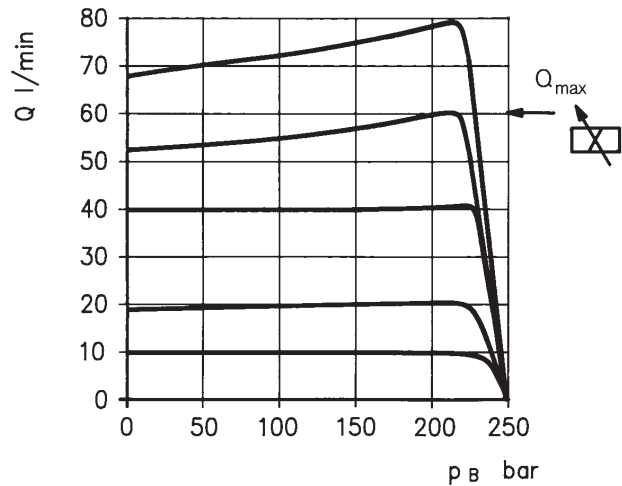

3-way version

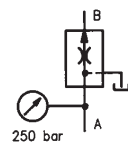

$Q_{nom} = 60 \text{ l/min}$

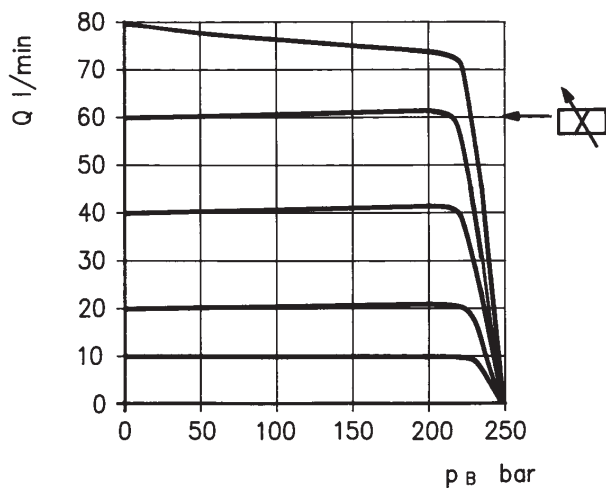

Residual flow "A-P"
(pressure drop)

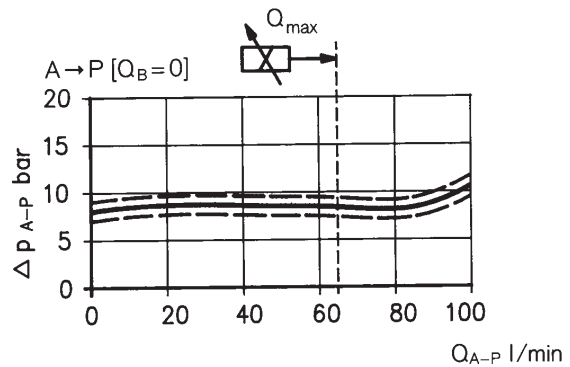
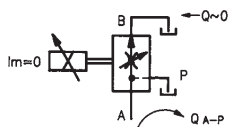

Unit dimensions NG6 (nominal dimensions in mm)

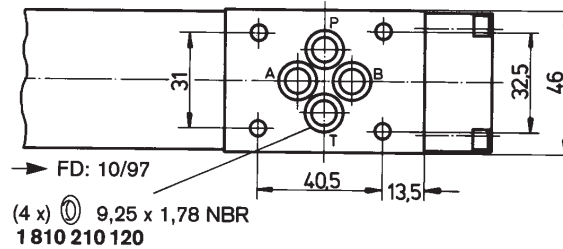

Manual auxiliary override N12

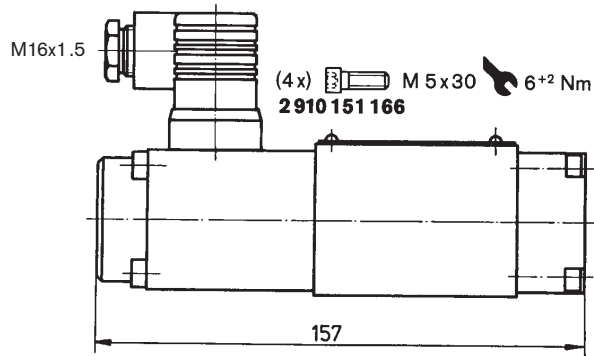
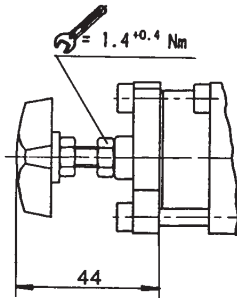

Required surface quality
of mating component

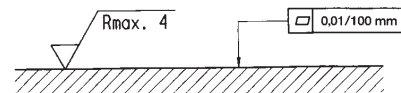

Mounting hole configuration: NG6 (ISO 4401-03-02-0-05)

For subplates, see catalog sheet RE 45053

- 1) Deviates from standard
- 2) Thread depth:
Ferrous metal 1.5 x Ø
Non-ferrous 2 x Ø

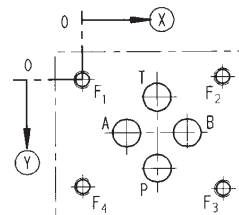

	P	A	T	B	F ₁	F ₂	F ₃	F ₄
⊗	21.5	12.5	21.5	30.2	0	40.5	40.5	0
⊙	25.9	15.5	5.1	15.5	0	-0.75	31.75	31
∅	8 ¹⁾	8 ¹⁾	8 ¹⁾	8 ¹⁾	M5 ²⁾	M5 ²⁾	M5 ²⁾	M5 ²⁾

Unit dimensions NG10 (nominal dimensions in mm)

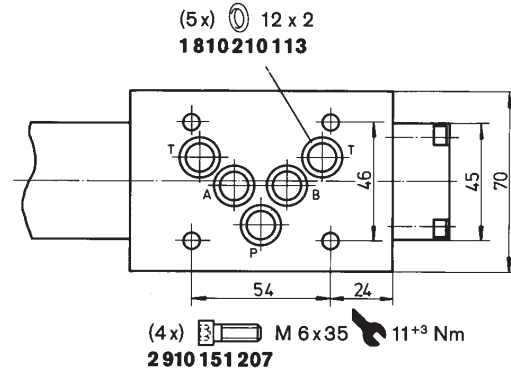

Manual auxiliary override N12

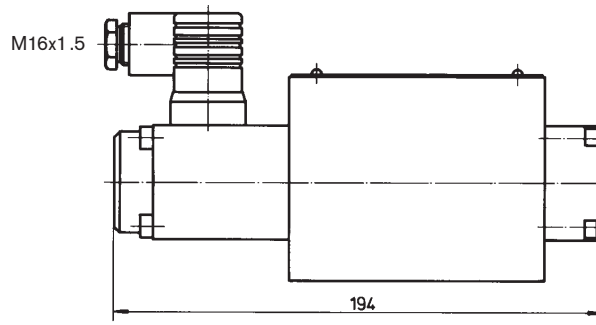
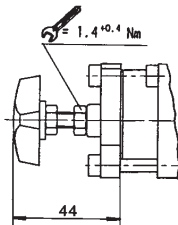

Required surface quality
of mating component

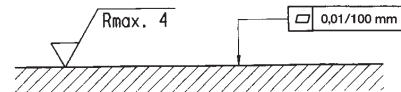

Mounting hole configuration: NG10 (ISO 4401-05-04-0-05)
For subplates, see catalog sheet RE 45055

- 1) Deviates from standard
- 2) Thread depth:
Ferrous metal 1.5 x \varnothing *
Non-ferrous 2 x \varnothing
- * NG10 min. 10.5 mm

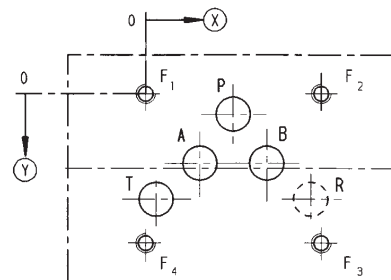

	P	A	T	B	F ₁	F ₂	F ₃	F ₄	R
⊗	27	16.7	3.2	37.3	0	54	54	0	50.8
⊙	6.3	21.4	32.5	21.4	0	0	46	46	32.5
∅	10.5 ¹⁾	10.5 ¹⁾	10.5 ¹⁾	10.5 ¹⁾	M6 ²⁾	M6 ²⁾	M6 ²⁾	M6 ²⁾	10.5 ¹⁾

Notes

© This document, as well as the data, specifications and other information set forth in it, are the exclusive property of Bosch Rexroth AG. It may not be reproduced or given to third parties without its consent.
The data specified above only serve to describe the product. No statements concerning a certain condition or suitability for a certain application can be derived from our information. The information given does not release the user from the obligation of own judgement and verification. It must be remembered that our products are subject to a natural process of wear and aging.