

Electric Drives
and Controls

Hydraulics

Linear Motion and
Assembly Technologies

Pneumatics

Service

Rexroth
Bosch Group

Booster amplifier

Type VT-MSFA1

RE 30260-B/07.12

English

Operating instructions

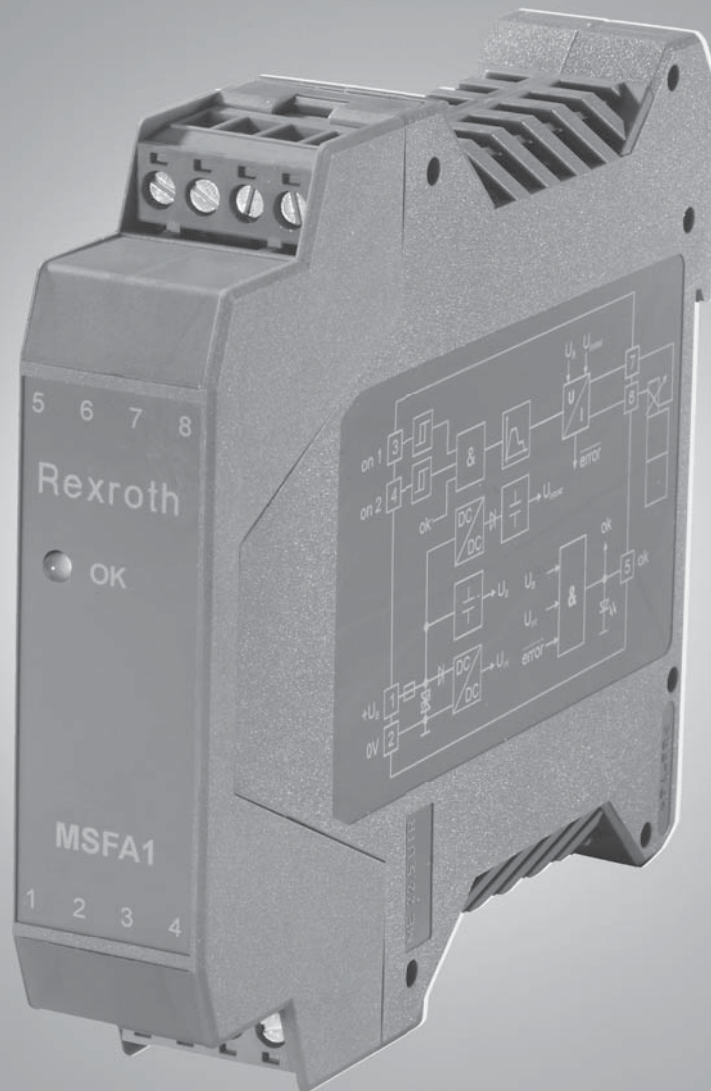

The data specified above only serve to describe the product. No statements concerning a certain condition or suitability for a certain application can be derived from our information. The information given does not release the user from the obligation of own judgment and verification. It must be remembered that our products are subject to a natural process of wear and aging.

© This document, as well as the data, specifications and other information set forth in it, are the exclusive property of Bosch Rexroth AG. It may not be reproduced or given to third parties without its consent.

The cover page shows an example configuration. The product supplied may therefore differ from the figure shown.

The original operating instructions were prepared in German.

Inhalt

1	About this documentation.....	5
1.1	Validity of the documentation	5
1.2	Required and amending documentation	5
1.3	Representation of information	5
1.3.1	Safety instructions.....	6
1.3.2	Symbols	6
1.3.3	Designations	7
2	Safety instructions.....	7
2.1	General information on this chapter.....	7
2.2	Intended use	7
2.3	Improper use.....	7
2.4	Qualification of personnel.....	8
2.5	General safety instructions.....	8
2.6	Product- and technology-dependant safety instructions	9
3	General warnings of damage to property and damage to the product.....	10
4	Scope of delivery	11
5	Information on this product	11
5.1	Performance description	11
5.2	Product description	12
5.2.1	Block diagram /pin assignment	12
5.2.2	Description of the individual components of the booster amplifier.....	12
5.2.3	Monitoring functions.....	14
5.3	Product identification.....	14
6	Transport and storage.....	15
6.1	Storing the VT-MSFA1	15
7	Assembly	15
7.1	Installation conditions.....	16
7.2	Necessary tools.....	17
7.3	Recommended accessories.....	17
7.4	Assembling the VT-MSFA1	17
7.4.1	System-specific circuitry of the booster amplifier.....	18
7.4.2	Connection overview.....	19
7.4.3	Connection of the power supply unit.....	20
7.4.4	Connection of the on/off valve.....	21
7.4.5	Connection of the control system.....	21
7.4.6	Plug-in screw connectors	21
8	Commissioning	22
9	Operation	22
10	Maintenance and repair	23
10.1	Cleaning and care (maintenance).....	23
10.2	Maintenance.....	23
10.3	Repair.....	23
11	Disassembly and replacement.....	23
11.1	Preparing disassembly.....	23
11.2	Disassembling the VT-MSFA1	24
11.3	Preparing the components for storage/further use.....	24
12	Disposal	24
12.1	Environmental protection	24
13	Extension and modification	24
14	Troubleshooting.....	24
14.1	How to proceed for troubleshooting	24
15	Technical data	25

16	Appendix.....	25
16.1	List of addresses	25
16.1.1	Contact person for repair	25
16.1.2	Contact person for support.....	25
17	Alphabetical index	26

1 About this documentation

1.1 Validity of the documentation

This documentation applies to the following product:

- VT-MSFA1-XXX-1X/V0 in the following variants:
- VT-MSFA1-50-1X/V0 (for KSDE valve with coil 2.3 Ohm at 1.76 A), mat. no. R901306231
- VT-MSFA1-100-1X/V0 (for 4SEC6...SO843 valve), mat. no. R901306230
- VT-MSFA1-150-1X/V0 (for 4WE6...SO893 valve), mat. no. R901306229

This documentation is intended for assemblers, operators and service engineers and system end-users.

This documentation contains important information on the safe and appropriate assembly, transport, commissioning, operation, use, maintenance, disassembly and simple troubleshooting of the product.

- ▶ Read this documentation completely and particularly chapter 2 "Safety instructions" before working with the product.

1.2 Required and amending documentation



- ▶ The product must not be commissioned until you have been provided with the documentation marked with the book symbol  and you have understood and observed it.

Table 1: Required and amending documentation

	Title	Document number	Document type
	Booster amplifier	RE 30260	Data sheet
	Capacitor module	RE 30750	Data sheet
	Environmental compatibility statement for the areas EMC, climate and mechanical load	RE 30260-U	Environmental declaration
	2/2 directional seat valve, direct operated with solenoid actuation, type KSDE	RE 18136-23	Data sheet
	3/3, 4/2 and 4/3 directional seat valve with solenoid actuation, type SEC6	RE 22035	Data sheet
	4/3, 4/2 and 3/2 directional valve with wet-pin DC solenoids	RE 23178	Data sheet
	Compact power supply unit VT-NE30-2X	RE 29929	Data sheet

1.3 Representation of information

Consistent safety instructions, symbols, terms and abbreviations are used so that you can quickly and safely work with your product using this documentation. For a better understanding, they are explained in the following sections.

About this documentation

1.3.1 Safety instructions

In this documentation, safety instructions are indicated whenever sequences of actions are explained which bear the danger of personal injury or damage to property. The measures described for the hazard avoidance must be observed.

Safety instructions are set out as follows:

! SIGNAL WORD
<p>Type and source of danger</p> <p>Consequences in case of non-compliance</p> <p>▶ Measures for the hazard avoidance</p>

- **Warning sign:** Draws attention to the danger
- **Signal word:** Identifies the degree of danger
- **Type and source of danger:** Specifies the type and source of danger
- **Consequences:** Describes the consequences in case of non-compliance
- **Precautions:** Specifies how the danger can be prevented

Table 2: Risk classes according to ANSI Z535.6-2006

Warning sign, signal word	Meaning
! DANGER	Indicates a dangerous situation which will cause death or severe personal injuries if not avoided.
! WARNING	Indicates a dangerous situation which may cause death or severe personal injuries if not avoided.
! CAUTION	Indicates a dangerous situation which may cause minor or medium personal injuries if not avoided.
NOTICE	Damage to property: The product or the environment could be damaged.

1.3.2 Symbols

The following symbols indicate notices which are not safety-relevant but increase the comprehensibility of the documentation.

Table 3: Meaning of the symbols

Symbol	Meaning
	If this information is not observed, the product cannot be used and/or operated optimally.
▶	Individual, independent action
1. 2. 3.	Numbered instruction: The numbers indicate that the steps must be carried out one after the other.

Safety instructions

1.3.3 Designations

The following designations are used in this documentation:

Table 4: Designations

Designation	Meaning
VT-MSFA1	Booster amplifier
UB	Operating voltage

2 Safety instructions

2.1 General information on this chapter

The booster amplifier was designed and manufactured according to the generally accepted code of practice. However, there is still the danger of personal injury and damage to property if you do not observe this chapter and the safety instructions in this documentation.

- ▶ Read this documentation completely and thoroughly before working with the product.
- ▶ Keep this documentation in a location where it is accessible to all users at all times.
- ▶ Always include the required documentation when you pass the product on to third parties.
- ▶ Only operate the VT-MSFA1 booster amplifier in a technically immaculate condition and as intended, in a safety- and risk-conscious manner, considering these instructions.
- ▶ In case of faults impairing the safety and modifications to the operating behavior, shut down the VT-MSFA1 immediately and report the faults to the responsible personnel.

2.2 Intended use

The VT-MSFA1 boost amplifier is an electrical component.

You may use the product as follows:

- To control hydraulic on/off valves which have to be switched quickly.
- To create the clocked solenoid current for the on/off valves released according to the data sheet.

The product is only intended for professional use and not for private use.

Intended use includes having read and understood this documentation completely, especially the chapter 2 "Safety instructions".

2.3 Improper use

Any use deviating from the intended use is improper and thus not admissible.

Safety instructions

The installation or use of inappropriate products in safety-relevant applications could result in unintended operating conditions when being used which in turn could cause personal injuries and/or damage to property. Therefore please only use a product for safety-relevant applications if this use is expressly specified and permitted in the documentation of the product. For example in explosion protection areas or in safety-related parts of control systems (functional safety).

Bosch Rexroth AG does not assume any liability for damage caused by improper use. The user assumes all risks involved with improper use.

Improper use of the product includes:

- Using the booster amplifier outside the specified performance limits and operating conditions and in particular the specified environmental conditions.

2.4 Qualification of personnel

The activities described in this documentation require basic knowledge of electrics and hydraulics as well as knowledge of the appropriate technical terms. In order to ensure safe use, these activities may only be carried out by a corresponding expert or an instructed person under the direction and supervision of an expert.

Experts are those who can recognize potential dangers and apply the appropriate safety measures due to their technical training, knowledge and experience, as well as their understanding of the relevant provisions pertaining to the work to be undertaken. An expert must observe the relevant specific professional rules.

2.5 General safety instructions

- Observe the valid regulations on accident prevention and for environmental protection.
- Observe the safety regulations and provisions of the country where the product is implemented/used.
- Exclusively use Rexroth products in technically perfect condition.
- Observe all notices on the product.
- Persons who assemble, operate, disassemble or maintain Rexroth products must not consume any alcohol, drugs or pharmaceuticals that may affect their ability to react.
- Only use accessories and spare parts approved by the manufacturer in order to exclude hazards to persons due to unsuitable spare parts.
- Comply with the technical data and environmental conditions specified in the product documentation.
- The installation or use of inappropriate products in safety-relevant applications could result in unintended operating conditions when being used which in turn could cause personal injuries and/or damage to property. Therefore please only use a product for safety-relevant applications if this use is expressly specified and permitted in the documentation of the product.
- Do not commission the product until you can be sure that the end product (for example a machine or system) where the Rexroth product is installed complies with the country-specific provisions, safety regulations and standards of the application.

Safety instructions

- Please observe the safety-relevant information and risk specifications in the operating instructions of the manufacturer of the connected hydraulic system before commissioning the booster amplifier with a hydraulic system.
- Technical data as well as connection and installation conditions are available in the product documentation and must be imperatively observed.
- Please observe the general installation and safety instructions when working on electric systems.
- You must generally not modify or retrofit the product.

2.6 Product- and technology-dependant safety instructions

WARNING

Dangerous movement!

Risk of injury due to incorrect control of the fast switching valve via the booster amplifier and unforeseeable machine movements caused in this way.

- ▶ Only operate the amplifier with the valve/coil combinations released in the type key.
- ▶ Comply with the safety according to EN 13849 or IEC 62061.
- ▶ If persons must access the danger zone during active control, monitoring or measures must be provided for personal safety which are superior to the system. These measures must be provided according to the specific data of the system and on the basis of the risk and failure analysis of the system manufacturer/user. In this connection, the safety provisions applied for the system must be taken into account.
- ▶ The electronics always causes interference on other electronics, which lies within the limit values. Thus, malfunctions in the control are possible. Only use electronics under the EMC limit values or provide for corresponding screening.
- ▶ The electronics of the VT-MSFA1 booster amplifier reacts to electro-magnetic interference of unshielded, incorrectly laid or incorrectly connected signal lines. If the limit values specified in the data sheet are exceeded, malfunctions or uncontrolled movements are possible. Comply with the limit values specified in the data sheet; use only electronics under the EMC limit values or provide for corresponding screening.
- ▶ Electrostatic processes, an incorrect earthing concept or missing potential equalization may lead to damage to the electronics and thus cause malfunctions or uncontrolled movements at the machine. Provide for correct earthing and for potential equalization.
- ▶ If the product is used outside the specified IP protection class, short-circuits and malfunctions and thus uncontrolled machine movements may result. You may therefore only use the product within the IP protection class and environment specified in the data sheet.
- ▶ Separately provide for safety functions for the personal safety. The VT-MSFA1 booster amplifier itself does not include any safety functions for personal safety and is no safety-relevant component. The booster amplifier is solely used for the generation of the solenoid currents for on/off valves.

General warnings of damage to property and damage to the product

WARNING

High electrical voltage by incorrect connection!

Danger to life, risk of injury caused by electric shock.

- ▶ De-energize the relevant system part for all works and secure it against restarting.
- ▶ All connections and terminals with voltages between 0 and 50 Volt may only be connected with devices, electric components and lines with a protective extra-low voltage (PELV).
- ▶ Only connect voltages and electric circuits provided with a safe isolation from dangerous voltages. Safe isolation can be achieved, for example, by isolating transformers, safe optocouplers or mains-free battery operation.

Stroke of lightning!

Risk of uncontrolled machine movements.

- ▶ An incorrect earthing concept or potential equalization may lead to damage to the electronics. Provide for potential equalization for the device.

Failures and errors in the control circuits or the energy supply!

Risk of uncontrolled machine movements.

- ▶ Comply with the safety according to EN ISO 13849 or IEC 62061.

CAUTION

Hot surfaces!

Risk of burning.

- ▶ System parts may become hot during operation. Allow the system parts to cool down before touching them or wear protective gloves.

3 General warnings of damage to property and damage to the product

NOTICE

High voltage!

Possible damage to the booster amplifier.

- ▶ Only wire the booster amplifier in the de-energized condition.

High temperatures!

Possible damage to the booster amplifier.

- ▶ Do not use free-wheeling diodes in the solenoid conductors!

Wrong cables! Voltage loss, melting of the cable!

Risk of product damage.

- ▶ For solenoid conductors up to a length of 10 m, the wire cross-section must be 1.5 mm², for lengths from 10 - 25 m 2.5 mm². With greater lengths, please contact us!

NOTICE

Overload!

Risk of overload and damage to the supply line in case of insufficient design and/or operation with several electric devices.

- ▶ Provide for current limitation by means of overload protection.
- ▶ Dimension power supply unit and cable sufficiently.

Short-circuit!

Risk of overload and damage to the supply line in case of defects at the electric device.

- ▶ Provide for current limitation by means of overload protection.

Inadmissible temperature range!

Danger due to overheating. Device might be thermally destroyed.

- ▶ Comply with the specifications in the data sheet.

4 Scope of delivery

The scope of delivery includes:

- Booster amplifier

Accessories such as cable and power supply unit and cable sets are not included in the scope of delivery and must be ordered separately. See chapter 7.3 "Recommended accessories" on page 17.

5 Information on this product

5.1 Performance description

The VT-MSFA1 booster amplifier is used to control hydraulic on/off valves which are to be switched fast. The booster amplifier is available in three variants which control different valve coils each.

- VT-MSFA1-50-1X/V0 for KSDER valves with coil 2.3 Ohm / 1.76 A
- VT-MSFA1-100-1X/V0 for 4SEC6...SO843 valve
- VT-MSFA1-150-1X/V0 for 4WE6...SO893 valve

By means of the internally generated boost voltage which is connected to the valve solenoid during the boost phase and the resulting higher solenoid current ($\gg I_{\text{Nominal}}$) considerably reduced switching times of the valve can be achieved. In holding operation, the solenoid current is reduced. This reduces the actuator operating temperature which again favors a longer service life of the actuator.

5.2 Product description

The booster amplifier is snapped onto carrier rails according to DIN 50022. The electrical connection is established via individually removable plug-in screw connectors. The module is operated with 24 V direct voltage.

The internal power supply unit supplies all internally required positive and negative supply voltages and the boost voltage for the actuator overexcitation. Thus, no additional external voltage has to be fed in. As soon as the power supply unit is in operation, the green LED ("Ready for operation") lights up. In case of cable break, short circuit and internal errors, it will go out.

The booster amplifier comprises reversed polarity and short-circuit protection of the load circuit (output stage) and reversed polarity protection of the voltage supply terminals.

A 24 V status output "Ready for operation" is available for analysis, e.g. in a PLC. Two equivalent switching inputs (AND linked) are provided for the control of the booster amplifier.

The booster amplifier has an integrated fast shut-down.

5.2.1 Block diagram /pin assignment

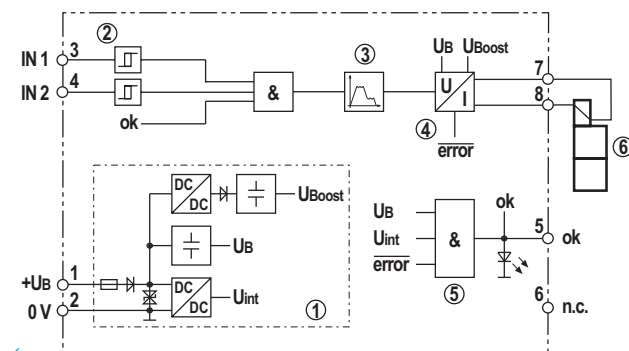

Fig. 1: Block diagram VT-MSFA1

- | | |
|-----------------------------------------|---------------------|
| 1 Power supply unit | 4 Output stage |
| 2 Switching inputs | 5 Fault recognition |
| 3 Voltage and current profile generator | 6 On/off valve |

5.2.2 Description of the individual components of the booster amplifier

The figures specified in brackets refer to the item numbers indicated in the block diagram.

Power supply unit (1) Switching inputs (2)

The internal power supply unit provides all internally required supply voltages. If voltage is applied to one of the two switching inputs "IN1" or "IN2" (2), which is less than / equal to the switch-off threshold, the output stage is switched off, irrespective of the current phase (boost, pull-in or holding phase) and the current actual current value. Then, there is a fast shut-down of the valve.

Information on this product

If voltage is applied to both switching inputs "IN1" and "IN2" (2), which is greater than / equal to the switch-on threshold, the output stage is activated.

Voltage and current profile generator (3)

If voltage is applied to both switching inputs "IN1" and "IN2" (2), which is greater than / equal to the switch-on threshold, the voltage and current profile generator will create an internal control signal for the output stage (4). This signal will be used by the output stage (4) for the generation of a voltage/current profile for the overexcitation of the valve solenoid (terminal 7 and 8).

Output stage (4)

If voltage is applied to both switching inputs "IN1" and "IN2" (2), which is greater than / equal to the switch-on threshold, the output stage is activated. By means of the voltage and current profile generator (3), the output stage generates a voltage/current profile (see figure 2) at the valve solenoid (terminal 7 and 8), which leads to overexcitation of the solenoid. This overexcitation allows for considerably reduced switching times of the valve.

I_A = Pull-in current
 I_H = Holding current
 I_L = Charging current

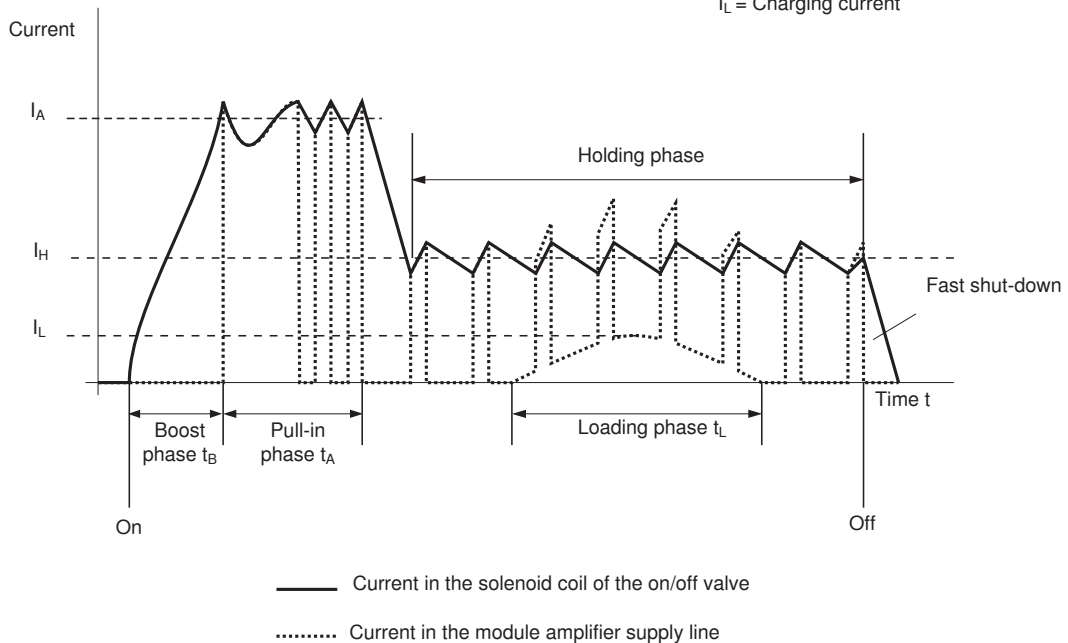

Fig. 2: Current profile of the VT-MSFA1

The output stage outputs (terminals 7 and 8) are protected against reversed polarity and short-circuit. Apart from that, the output stage will be de-energized if one of the two switching signals "IN1" or "IN2" is missing or if a fault is identified.



In order to ensure fast shut-down of the valve, no free-wheeling diode must be connected to the solenoid of the on/off valve!

Information on this product

5.2.3 Monitoring functions

It is the task of the booster amplifier monitoring functions to identify faults in the system and in the solenoid conductors and to initiate the corresponding measures in case of fault.

Fault recognition (5) In case of fault, the output stage is deactivated. The "Ready for operation" output (terminal 5) is switched off (high-impedance output > 20 kOhm) and the green "Ready for operation" LED on the front side goes out.

The fault recognition monitors the following:

- Undervoltage of +UB
- Cable break of the solenoid conductors (terminal 7 and 8)
- Short-circuit of the solenoid conductors (terminal 7 and 8)
- Connection of a high-impedance valve solenoid (greater 5 Ohm)

If there is no fault, the green "Ready for operation" LED at the front side is illuminated and the "Ready for operation" output is switched to +UB operating voltage.

If the value falls below the min. operating voltage $u_B(t)_{min}$, the required pull-in or holding current can no longer be guaranteed. The output stage is deactivated, the green "Ready for operation" LED at the front side goes out and the "Ready for operation" output is switched off.

Only if $u_B(t)_{min}$ is exceeded will the output stage be reactivated and the electronics changes into the fault-free operating state.



Attention: After the cause of error has been remedied and a voltage greater than / equal to the switch-on threshold has been applied to both switching inputs "IN1" and "IN2" (2), the output stage will be immediately activated. Afterwards, the electronics starts a new switching sequence.

As long as no valve or valve solenoid is connected at the booster amplifier, the green "Ready for operation" LED remains off and the "Ready for operation" output (terminal 5) remains switched off (high-impedance output > 20 kOhm).

5.3 Product identification

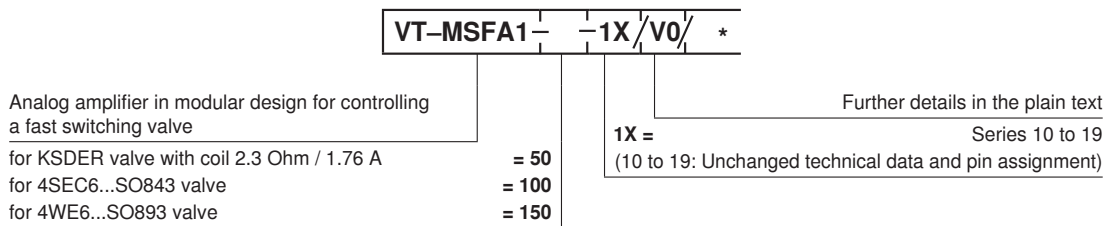

Fig. 3: Ordering code

6 Transport and storage

There are no special transport instructions for this product. You must, however, observe the notes in chapter 2 "General safety instructions" and comply with the environmental conditions for storage and transport which are detailed in the technical data of data sheet 30260.

6.1 Storing the VT-MSFA1

Proceed as follows in order to prepare the VT-MSFA1 booster amplifier for storage and further use:

- ▶ Only use the original packaging for storage.
- ▶ Comply with the admissible storage temperature range (see RE 30260).
- ▶ Protect the VT-MSFA1 from dust and humidity.

7 Assembly

WARNING

Pressure equipment or device parts flying around!

Risk of injury caused by parts flying around or oil jet spurting out if hydraulic parts or hydraulic lines have not been correctly or completely assembled before application of the pressure

- ▶ Depressurize the relevant part of the system before the assembly.
- ▶ Use sufficiently dimensioned connection threads with sealing points.
- ▶ Have the assembly performed by an expert according to these instructions and check the system before commissioning with corresponding overpressure according to ISO 4413.

CAUTION

Fault currents and short-circuits!

Impairment of safety and malfunctions.

- ▶ The environment must be free from electrically conductive contamination (acids, bases, corrosive agents, salts, metal vapors, etc.) and the device must not be exposed to these substances. Rule out any deposits according to protection class IP 20.

Cables lying around!

Risk of stumbling!

- ▶ Lay the cables and lines so that they cannot be damaged and no one can trip over them.

NOTICE

Major potential differences!

Danger of destroying the VT-MSFA1 by connecting or disconnecting plug-in connectors under voltage.

- ▶ Switch off power supply to the relevant system component before assembling the device or when connecting and disconnecting connectors. Damaged devices due to incorrect installation are not covered by the warranty!
- ▶ Observe protection class, voltage supply and environmental conditions according to data sheet RE 30260.

Interference!

Risk of malfunctions.

- ▶ The distance to radios must be sufficient ($\gg 1$ m).
- ▶ With a strongly fluctuating operating voltage, it may in the individual case be necessary to use an external smoothing capacitor with a capacity of at least 2200 μ F.
Recommendation: Capacitor module VT 11110-1X (see RE 30750); sufficient for up to 2 booster amplifiers.
- ▶ This module is intended for installation into a shielded EMC housing (control cabinet). All lines leading outwards are to be shielded whereas complete shielding is required.

Interference!

Risk of impairment of other devices.

- ▶ Use shielded signal lines and/or solenoid conductors and the VT-NE30 power supply unit (or comparable) for the VT-MSFA1 in order to satisfy the EMC requirements.

Overheating!

The device might be destroyed.

- ▶ Provide for sufficient air circulation by means of clearance area to the right, to the left, upwards and downwards. See fig. 4.

Condensed water!

Damage to the electronics and impaired functionality due to penetrating water.

- ▶ Allow the booster amplifier to acclimate itself before the assembly and switch-on.

7.1 Installation conditions

The VT-MSFA1 booster amplifier is intended for top hat rail mounting in the control cabinet in vertical installation position. The dimensions are listed in the data sheet RE 30260.

Make sure that there is sufficient clearance area to the right and to the left, at least 25 mm. By observing a minimum distance of 50 mm downwards and upwards, ensure sufficient air circulation to the ventilation slots in the housing.

Assembly

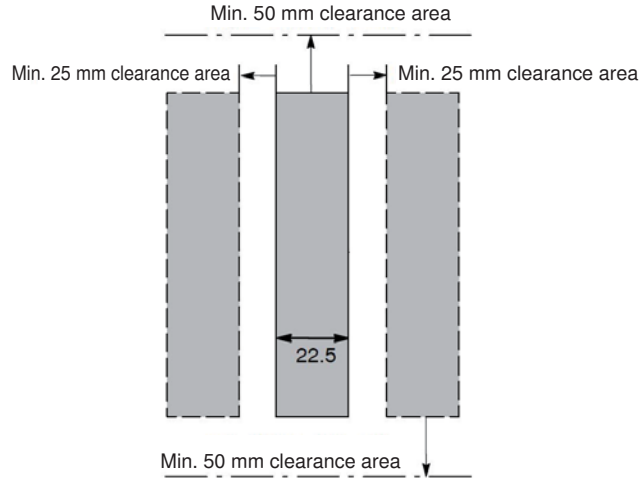

Fig. 4: Required distances

7.2 Necessary tools

No special tools are required for the assembly.

7.3 Recommended accessories

The following accessories are recommended for the connection of the VT-MSFA1 booster amplifier. These accessories are not included in the scope of delivery, and can be ordered separately from Bosch Rexroth.

Table 5: Accessories

Component	Material number
Capacitor module VT11110-1X	R900020293
Compact power supply unit VT-NE30-2X	R901082348

7.4 Assembling the VT-MSFA1

- ▶ For the assembly, observe the notices regarding applied standards and application conditions in the data sheet.
- ▶ Do not lay solenoid conductors and signal lines near power cables.
- ▶ Used shielded cables (EMC-compatible) for signal and valve lines.
- ▶ Do not use silicone-containing sealing, adhesive, or insulating agents.
- ▶ Ensure a maintenance-friendly installation, i.e. simple access to the connection lines. Free access to the connection side must be guaranteed. The cable ends should be sufficiently long so that the amplifier can also be dismantled in the wired condition.

Assembly

- ▶ Before installation note down the information on the name plates. If, after the installation, name plates are no longer visible or legible, these data will be quickly available to you at any time.
- ▶ Ensure during the assembly of several modules that there is still enough space for any subsequent removal of the booster amplifiers.

The installation position of the booster amplifier is vertical. It is assembled without tools on a carrier rail TH35-7,5 according to EN 60715 (top hat rail). Foot latches with spring pressure are provided for fixation of the module housing.

By snapping the housing of the VT-MSFA1 on a conductive assembly rail, the earthing connection is established. This constitutes the HF earthing of the VT-MSFA1 booster amplifier.

- ▶ Engage the booster amplifier on the carrier rail. A foot latch (with spring pressure) prevents loosening of the module housing from the carrier rail.
- ▶ For loosening the module, push the foot latch downwards.

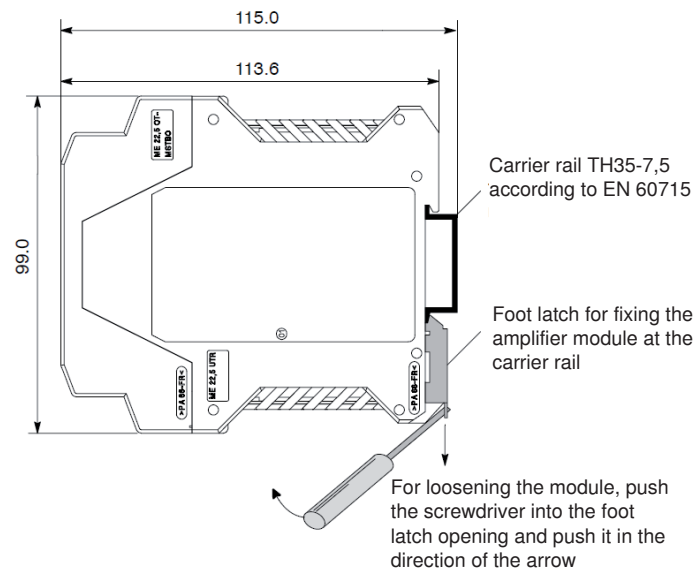

Fig. 5: Assembling/disassembling the booster amplifier

7.4.1 System-specific circuitry of the booster amplifier

All device connections (2 plug-in screw connectors, see chap. 7.6.4, 2-pole, wire cross-section: 0.2 mm² to 2.5 mm²) are located on the booster amplifier front side. Rigid or flexible wires are possible.



Limitations with regard to line length and cable thickness are possible depending on the mating connectors used of the components to be connected. Lay all lines (e. g. for supply, switching signals, valve solenoid, etc.) considering the technical data (input resistance, current consumption) with regard to cable thickness and length so that the operating data and working ranges (input voltages, current consumption) are complied with.

Assembly

The circuitry of the booster amplifier refers to the connection

- of the power supply unit (see chapter 7.4.3)
- of the valve (see chapter 7.4.4)
- of the superior control system (see chapter 7.4.5)

7.4.2 Connection overview

For the electrical connection, the machine manufacturer's connection diagrams and their work instructions are always binding!

Necessary components like e.g. EMERGENCY STOP circuits, mains switches, etc. must be provided and included by the system project planner according to the accepted state-of-the-art and best safety possible.

The VT-MSFA1 booster amplifier has 4 inputs and 3 outputs on 8 terminals.

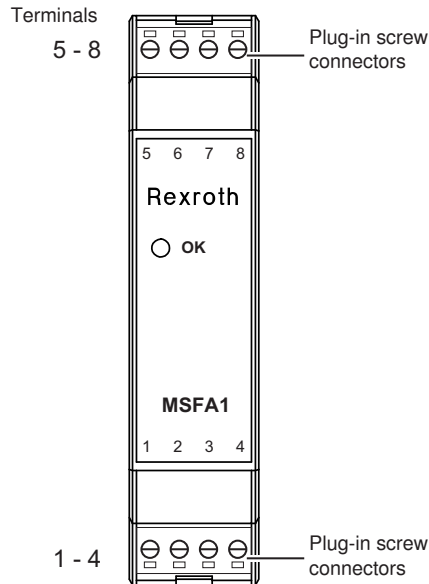

Fig. 6: Booster amplifier front view

Terminal assignment

Table 6: Overview of the terminals

Terminal	Terminal designation	Type	Comment	Supply line from / to
1	+UB	Input	Operating voltage	Power supply unit
2	0 V and/or ground	Input	Reference potential of the operating voltage +UB and the Ready for operation output	Power supply unit
3	IN1	Input	Output stage activation	Control
4	IN2	Input	("AND" connection of both signals)	Control

Assembly

Terminal	Terminal designation	Type	Comment	Supply line from / to
5	Ready for operation	Output (high active)	HIGH as soon as the internal power supply unit works and no errors are available.	Control
6	-	-	n.c.	
7		Output	Solenoid	Valve solenoid
8		Output	Solenoid	Valve solenoid

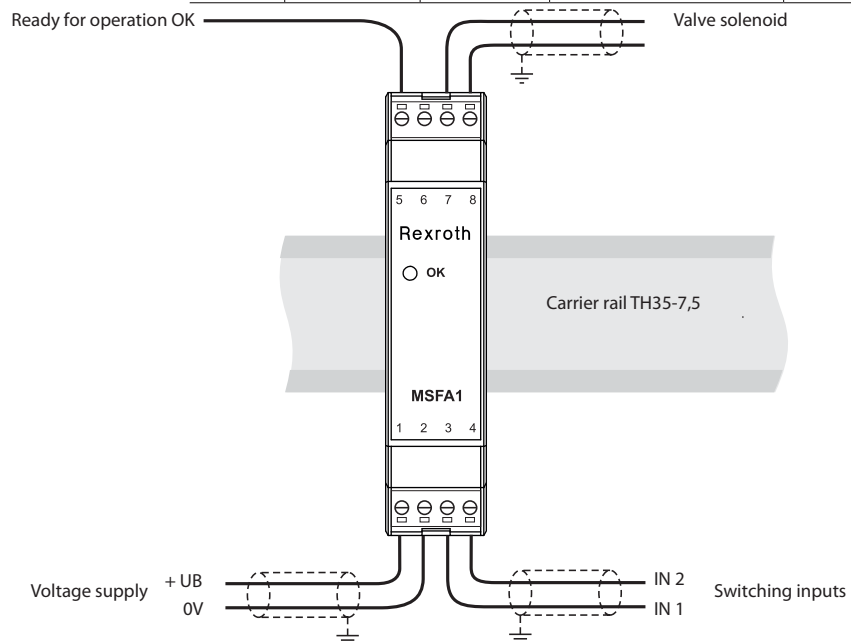

Fig. 7: Typical wiring

7.4.3 Connection of the power supply unit

NOTICE

Dangerous electrical voltage!

Risk of injury.

- ▶ Make sure that the 24 V DC input voltage satisfies the requirements of "safe isolation".

If possible, design the system circuit so that the booster amplifier and all coupled components are always switched on together.

The VT-MSFA1 booster amplifier uses the applied operating voltage to create the internally/externally required system voltages for

- Logic
- Output stage
- Signal processing

Assembly

The compact power supply unit VT-NE30-2X (see RE 29929) is a suitable power supply unit for the booster amplifier.

Table 7: Terminal assignment to the power supply unit

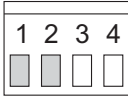
Terminal	Pin	Allocation	Explanation
	1	+UB	Reference potential of the operating voltage +UB
	2	0 V and/or ground	Operating voltage

7.4.4 Connection of the on/off valve

For the connection to the on/off valve, 2 terminal connections are reserved on the booster amplifier.

Table 8: Terminal assignment to the on/off valve

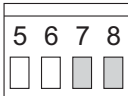
Terminal	Pin	Allocation	Explanation
	7		Connection for valve solenoid
	8		Connection for valve solenoid

7.4.5 Connection of the control system

For the connection of the booster amplifier to the superior control system, a total of 2 switching inputs and 1 "Ready for operation" output are available.

Table 9: Terminal assignment to the control system

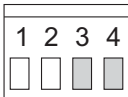
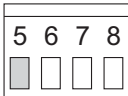
Terminal	Pin	Allocation	Explanation
	3	IN1	Activation of output stage (both signals are internally "AND" linked)
	4	IN2	
	5	Ready for operation	HIGH as soon as the internal power supply unit works and no errors are available.

7.4.6 Plug-in screw connectors

The booster amplifier offers the possibility to lead the connection lines to a total of 2 pluggable plug-in screw connectors. The latter can be removed from the module housing using a screwdriver (blade width approx. 2.5 mm) even if the booster amplifier is installed (see figure below).

In case of maintenance, you can for example exchange the booster amplifier without having to remount connection lines on new connectors.

Each of the 2 plug-in screw connectors comprises 4 terminal connections.

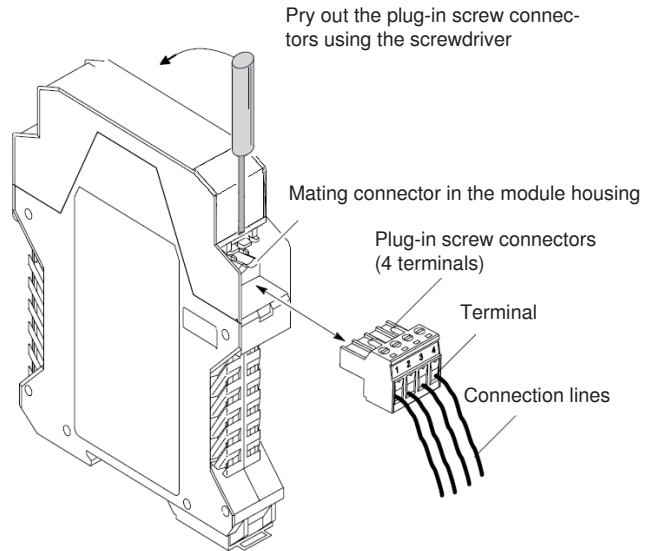

Fig. 8: Assembly/disassembly of the plug-in screw connectors

8 Commissioning

NOTICE

Uncontrolled connection or disconnection of plug-in connectors!

The device might be destroyed.

- ▶ Before installation works, and before connecting or disconnecting plug-in connectors to or from the device, the device must be disconnected from the voltage source or reliably de-energized. Damaged devices due to incorrect installation are not covered by the warranty!
- ▶ Observe protection class, voltage supply and environmental conditions according to data sheet RE 30260.

- ▶ Before commissioning, make sure that all the seals and caps of the plug-in connections are installed correctly and undamaged to ensure that fluids and foreign particles are prevented from penetrating the product.

9 Operation

During normal operation, the user does not need to intervene.

In case of power failure during operation, the booster amplifier can be activated again without any further measures and is then ready for operation.

10 Maintenance and repair

10.1 Cleaning and care (maintenance)

NOTICE

Operating failures!

Loss of functionality and short-circuit due to penetrating dirt and humidity!

- ▶ Always ensure absolute cleanliness when working at the VT-MSFA1 booster amplifier.
- ▶ Only use a dry and dust-free cloth for all cleaning works.

10.2 Maintenance

In order to ensure long service life and functionality, include the following activities in your maintenance schedule for the booster amplifier:

- ▶ Check all clamping connections for correct seat and damage at least once per year. Check lines for break or squeezing.
- ▶ Have defective or damaged parts exchanged immediately.

10.3 Repair

The VT-MSFA1 booster amplifier can only be exchanged as whole unit. For safety reasons, modifications at the VT-MSFA1 performed to one's own authority are not admissible! Repair and maintenance works may only be performed by Bosch Rexroth AG. For repair and maintenance works, send the device to the service address specified in chapter 15.

11 Disassembly and replacement

11.1 Preparing disassembly

NOTICE

Incorrectly performed disassembly!

The device might be destroyed!

- ▶ Decommission the overall system as described in the overall system instructions.
- ▶ De-energize the device and all connected components.

Disposal

11.2 Disassembling the VT-MSFA1

Disassemble the booster amplifier from the top hat rail as shown in chapter "Assembly", fig. 5 on page 18.

The plug-in screw connector is disassembled as shown in fig. 8 on page 22.

11.3 Preparing the components for storage/further use

Proceed as follows in order to prepare the VT-MSFA1 for storage and further use:

- ▶ Only use the original packaging for storage.
- ▶ Comply with the admissible storage temperature range specified in RE 30260.
- ▶ Protect the booster amplifier from dust and humidity.

12 Disposal

12.1 Environmental protection

Careless disposal of the VT-MSFA1 and the packaging material could lead to environmental pollution.

- ▶ Thus, dispose of the VT-MSFA1 and the packaging material in accordance with the national regulations in your country and recycle the material, if possible.

13 Extension and modification

The VT-MSFA1 booster amplifier must neither be extended nor converted. If you convert the VT-MSFA1, warranty will expire.

14 Troubleshooting

14.1 How to proceed for troubleshooting

- Always work systematically and targeted, even when under time pressure. Random, thoughtless disassembly and changing of settings can, in the worst-case-scenario, result in the inability to determine the original error cause.
- First get a general idea of how your product works in conjunction with the overall system.
- Try to find out whether the product has worked properly in conjunction with the overall system before the error occurred first.

Technical data

- Try to determine any changes of the overall system in which the product is integrated:
 - Were there any changes to the product's operating conditions or area of application?
 - Were there any changes (e. g. refittings) or repairs been carried out at the overall system (machine/system, electrical systems, control) or at the product? If yes: What were they?
 - Was the product or machine used as intended?
 - How did the fault become apparent?
 - Try to get a clear idea of the cause of the error. Ask the direct (machine) operator.

If you could not remedy the occurred error, please contact one of the addresses you find at www.boschrexroth.com or in the list of addresses in the appendix.

15 Technical data

You can find the technical data in the data sheet RE 30260.

16 Appendix

16.1 List of addresses

16.1.1 Contact person for repair

Bosch Rexroth AG
Service Industriehydraulik [Industrial hydraulics]
Bgm.-Dr. Nebel-Str. 8
97816 Lohr am Main
Germany
<http://www.boschrexroth.com/service>
Email: service@boschrexroth.de

16.1.2 Contact person for support

Bosch Rexroth AG
Zum Eisengießer 1
97816 Lohr am Main
Germany

Phone +49 (93 52) 18-11 32
Fax +49 (93 52) 18-33 63

17 Alphabetical index

A

Accessories 17
Assembly 15

B

Block diagram 12

C

Cleaning and care (maintenance) 23
Commissioning 22
Connection
 Control 21
 On/off valve 21
 Power supply unit 20
Connection overview 19
Contact person
 Repair 25
 Support 25
Control
 Connection 21
Current profile 13

D

Damage to property 10
Designations 7
Disassembly 23
 Preparing 23
Disposal 24
Documentation
 Required and amending 5

E

Environmental protection 24
Exchange 23
Extension and modification 24

F

Fault recognition 14

G

General safety instructions 8

I

Improper use 7
Individual components 12
Installation conditions 16
Intended use 7

L

List of addresses 25

M

Maintenance 23
Maintenance and repair 23
Monitoring functions 14

O

On/off valve
 Connection 21
 Operation 22
Output stage 13

P

Paragraph formats
 Heading2 11
Performance description 11
Pin assignment 12
Plug-in screw connectors 21
Power supply unit 12
 Connection 20
Product- and technology-dependant
 safety instructions 9
Product description 12
Product identification 14

Q

Qualification 8

R

Repair 23
 Contact person 25

S

Safety instructions 7
 General 8
 Product- and technology-dependant 9
 Product-dependent 9
 Signal word 6
Scope of delivery 11
Support
 Contact person 25
Switching inputs 12
Symbols 6
System-specific circuitry 18

T

Technical data 25
Terminal assignment 19
Tools
 required 17
Transport and storage 15
Troubleshooting 24

V

Voltage and current profile generator 13

Rexroth
Bosch Group

Subject to change without notice
Printed in Germany
RE 30260-B/07.12