

## CLSG-Series, High Tonnage Cylinders

**ENERPAC**  
POWERFUL SOLUTIONS. GLOBAL FORCE.

▼ Shown from left to right: CLSG-506, CLSG-5006, CLSG-4006



- Integral stop ring provides piston blow-out protection
- Baked enamel outside finish and plated pistons provide superior corrosion protection
- Interchangeable, hardened grooved saddles are standard
- Base mounting holes are standard on all models
- Plunger wiper reduces contamination, extending cylinder life
- Single-acting, load return.

▼ Eight CLSG-2506 cylinders equipped with tilting saddles lifted the planking of the bridge as the pier heads were being rebuilt.



## The Single-Acting Heavy Lifting Solution with Integral Stop Ring



### Saddles

All CLSG-Series cylinders are equipped with bolt-on removable grooved saddles. For information on optional tilt saddles, see selection chart.



### Gauges

Minimize the risk of overloading and ensure long, dependable service from your equipment. Refer to the System Components Section for a full range of gauges.



### Optimum Performance

Enerpac's range of Z-Class electric pumps, fitted with manual or solenoid operated 3-way valves, offer optimum combinations with CLSG cylinders.



### Low Height - High Tonnage

When low height with high force is required, CLP-Series Pancake Cylinders with locknut offer the solution to lift the first few centimetres.



### Standard Features

- Interchangeable, hardened grooved saddles
- Top and side mounted lifting eye capability
- CR-400 coupler and dustcap
- All cylinders meet ASME B-30.1 and ISO 10100 standards.

## Single-Acting, High Tonnage Cylinders

### ▼ QUICK SELECTION CHART

For complete technical information see next page.

Cylinder Capacity ton (kN)	Stroke (mm)	Model Number	Cylinder Effective Area (cm <sup>2</sup> )	Oil Capacity (cm <sup>3</sup> )	Collapsed Height (mm)	 (kg)
50 (539)	50	CLSG-502	77,0	385	162	17
	100	CLSG-504	77,0	770	212	20
	150	CLSG-506	77,0	1155	262	23
	200	CLSG-508	77,0	1540	312	27
	250	CLSG-5010	77,0	1924	362	31
	300	CLSG-5012	77,0	2309	412	34
100 (929)	50	CLSG-1002	132,7	664	182	19
	100	CLSG-1004	132,7	1327	232	29
	150	CLSG-1006	132,7	1991	282	40
	200	CLSG-1008	132,7	2655	332	50
	250	CLSG-10010	132,7	3318	382	61
	300	CLSG-10012	132,7	3982	432	71
150 (1390)	50	CLSG-1502	198,6	993	196	39
	100	CLSG-1504	198,6	1986	246	52
	150	CLSG-1506	198,6	2978	296	65
	200	CLSG-1508	198,6	3971	346	78
	250	CLSG-15010	198,6	4964	396	92
	300	CLSG-15012	198,6	5957	446	105
200 (1861)	50	CLSG-2002	265,9	1330	216	55
	150	CLSG-2006	265,9	3989	316	91
	300	CLSG-20012	265,9	7977	466	146
250 (2565)	50	CLSG-2502	366,4	1832	235	102
	150	CLSG-2506	366,4	5497	335	136
	300	CLSG-25012	366,4	10993	485	207
300 (3193)	50	CLSG-3002	456,2	2281	312	184
	150	CLSG-3006	456,2	6843	412	232
	300	CLSG-30012	456,2	13685	562	303
400 (3919)	50	CLSG-4002	559,9	2800	375	270
	150	CLSG-4006	559,9	8399	475	330
	300	CLSG-40012	559,9	16797	625	421
500 (5114)	50	CLSG-5002	730,6	3653	419	401
	150	CLSG-5006	730,6	10959	519	480
	300	CLSG-50012	730,6	21918	669	599
600 (5987)	50	CLSG-6002	855,3	4276	429	474
	150	CLSG-6006	855,3	12829	529	565
	300	CLSG-60012	855,3	25659	679	701
800 (8234)	50	CLSG-8002	1176,3	5881	474	741
	150	CLSG-8006	1176,3	17644	574	880
	300	CLSG-80012	1176,3	35288	724	1058
1000 (10260)	50	CLSG-10002	1465,7	7329	564	1062
	150	CLSG-10006	1465,7	21986	664	1213
	300	CLSG-100012	1465,7	43972	814	1439

### CLSG Series



Capacity:  
**50 - 1000 ton**

Stroke:  
**50 - 300 mm**

Maximum Operating Pressure:  
**700 bar**



#### Higher Capacities

1500 and 2000 ton models available on request.

#### Additional Stroke Lengths

Models above 150 ton are also available with standard stroke lengths of 100, 200 and 250 mm. Please contact Enerpac for ordering information.



#### Lifting an Unbalanced Load?

When lifting an unbalanced load the **EVO-Series Enerpac Integrated Lifting**

**Systems** can be the solution with multiple lift point capabilities from 4 to 48 points. See our "Yellow Pages" for multi-cylinder set-ups.



#### Optional features

To add optional features to your cylinders, add the following suffix to the end of the model number.

Collar thread \* **E002**

\* On 400 ton models and higher.

Example:

- For CLSG-5006 cylinder with collar thread, order: **CLSG-5006E002**

Technical specifications for these features are available from Enerpac.

## CLSG-Series, High Tonnage Cylinders

**ENERPAC**  
POWERFUL SOLUTIONS. GLOBAL FORCE.

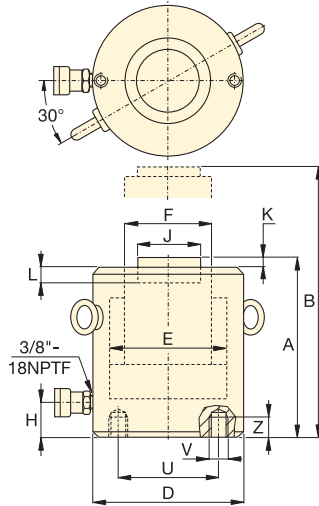

CLSG-502 - CLSG-15012

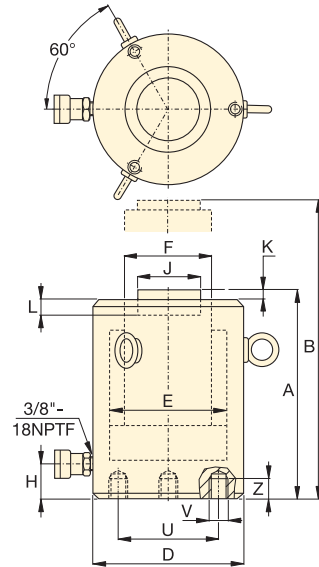

CLSG-2002 - CLSG-100012

Base Mounting Hole <sup>1)</sup> Dimensions (mm)			
Model / Capacity ton	Bolt Circle U	Thread Size V	Min. Thread Depth Z
CLSG-50	65	2x M12	22
CLSG-100	95	2x M12	22
CLSG-150	130	2x M12	22
CLSG-200	165	3x M12	22
CLSG-250	190	3x M12	22
CLSG-300	180	3x M16	30
CLSG-400	205	3x M16	30
CLSG-500	250	3x M24	36
CLSG-600	275	3x M24	36
CLSG-800	330	3x M24	36
CLSG-1000	375	3x M24	36

<sup>1)</sup> Base mounting holes are random positioned in regard to coupler position.



### Mounting Hole Orientation

Top mounting hole orientation is maintained to port location. Base mounting hole orientation is not maintained to port location.

◀ For full features see previous page.

Cylinder Capacity ton (kN)	Stroke (mm)	Model Number	Cylinder Effective Area (cm <sup>2</sup> )	Oil Capacity (cm <sup>3</sup> )
50 (539)	50	CLSG-502	77,0	385
	100	CLSG-504	77,0	770
	150	CLSG-506	77,0	1155
	200	CLSG-508	77,0	1540
	250	CLSG-5010	77,0	1924
	300	CLSG-5012	77,0	2309
100 (929)	50	CLSG-1002	132,7	664
	100	CLSG-1004	132,7	1327
	150	CLSG-1006	132,7	1991
	200	CLSG-1008	132,7	2655
	250	CLSG-10010	132,7	3318
	300	CLSG-10012	132,7	3982
150 (1390)	50	CLSG-1502	198,6	993
	100	CLSG-1504	198,6	1986
	150	CLSG-1506	198,6	2978
	200	CLSG-1508	198,6	3971
	250	CLSG-15010	198,6	4964
	300	CLSG-15012	198,6	5957
200 (1861)	50	CLSG-2002	265,9	1330
	150	CLSG-2006	265,9	3989
	300	CLSG-20012	265,9	7977
250 (2565)	50	CLSG-2502	366,4	1832
	150	CLSG-2506	366,4	5497
	300	CLSG-25012	366,4	10993
300 (3193)	50	CLSG-3002	456,2	2281
	150	CLSG-3006	456,2	6843
	300	CLSG-30012	456,2	13685
400 (3919)	50	CLSG-4002	559,9	2800
	150	CLSG-4006	559,9	8399
	300	CLSG-40012	559,9	16797
500 (5114)	50	CLSG-5002	730,6	3653
	150	CLSG-5006	730,6	10959
	300	CLSG-50012	730,6	21918
600 (5987)	50	CLSG-6002	855,3	4276
	150	CLSG-6006	855,3	12829
	300	CLSG-60012	855,3	25659
800 (8234)	50	CLSG-8002	1176,3	5881
	150	CLSG-8006	1176,3	17644
	300	CLSG-80012	1176,3	35288
1000 (10260)	50	CLSG-10002	1465,7	7329
	150	CLSG-10006	1465,7	21986
	300	CLSG-100012	1465,7	43972

## Single-Acting, High Tonnage Cylinders

Optional Tilt Saddle \*

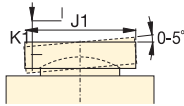

Capacity:  
**50 - 1000 ton**

Stroke:  
**50 - 300 mm**

Maximum Operating Pressure:  
**700 bar**

**CLSG**  
Series



Collapsed Height A (mm)	Extended Height B (mm)	Outside Dia. D (mm)	Cylinder Bore Dia. E (mm)	Plunger Dia. F (mm)	Base to Adv. Port H (mm)	Standard Saddle Dia. J (mm)	Saddle Protr. from Plgr. K (mm)	Depth of Plunger Hole L (mm)	 (kg)	Model Number	* Optional Tilt Saddle		
											Saddle Dia. J1 (mm)	Saddle Height K1 (mm)	Saddle Model Number
162	212	130	99,0	70,0	52	50	1	19	17	CLSG-502	50	24	CATG-50
212	312	130	99,0	70,0	52	50	1	19	20	CLSG-504	50	24	CATG-50
262	412	130	99,0	70,0	52	50	1	19	23	CLSG-506	50	24	CATG-50
312	512	130	99,0	70,0	52	50	1	19	27	CLSG-508	50	24	CATG-50
362	612	130	99,0	70,0	52	50	1	19	31	CLSG-5010	50	24	CATG-50
412	712	130	99,0	70,0	52	50	1	19	34	CLSG-5012	50	24	CATG-50
182	232	165	130,0	95,0	54	75	1	19	19	CLSG-1002	73	29	CATG-100
232	332	165	130,0	95,0	54	75	1	19	29	CLSG-1004	73	29	CATG-100
282	432	165	130,0	95,0	54	75	1	19	40	CLSG-1006	73	29	CATG-100
332	532	165	130,0	95,0	54	75	1	19	50	CLSG-1008	73	29	CATG-100
382	632	165	130,0	95,0	54	75	1	19	61	CLSG-10010	73	29	CATG-100
432	732	165	130,0	95,0	54	75	1	19	71	CLSG-10012	73	29	CATG-100
196	246	205	159,0	114,0	61	94	1	19	39	CLSG-1502	91	31	CATG-150
246	346	205	159,0	114,0	61	94	1	19	52	CLSG-1504	91	31	CATG-150
296	446	205	159,0	114,0	61	94	1	19	65	CLSG-1506	91	31	CATG-150
346	546	205	159,0	114,0	61	94	1	19	78	CLSG-1508	91	31	CATG-150
396	646	205	159,0	114,0	61	94	1	19	92	CLSG-15010	91	31	CATG-150
446	746	205	159,0	114,0	61	94	1	19	105	CLSG-15012	91	31	CATG-150
216	266	235	184,0	133,0	67	113	1	24	55	CLSG-2002	118	35	CATG-200
316	466	235	184,0	133,0	67	113	1	24	91	CLSG-2006	118	35	CATG-200
466	766	235	184,0	133,0	67	113	1	24	146	CLSG-20012	118	35	CATG-200
235	285	275	216,0	165,0	73	145	1	24	102	CLSG-2502	144	46	CATG-250
335	485	275	216,0	165,0	73	145	1	24	136	CLSG-2506	144	46	CATG-250
485	785	275	216,0	165,0	73	145	1	24	207	CLSG-25012	144	46	CATG-250
312	362	310	241,0	197,0	101	177	1	19	184	CLSG-3002	160	62	CATG-300
412	562	310	241,0	197,0	101	177	1	19	232	CLSG-3006	160	62	CATG-300
562	862	310	241,0	197,0	101	177	1	19	303	CLSG-30012	160	62	CATG-300
375	425	350	267,0	216,0	114	196	3	27	270	CLSG-4002	193	51	CATG-400
475	625	350	267,0	216,0	114	196	3	27	330	CLSG-4006	193	51	CATG-400
625	925	350	267,0	216,0	114	196	3	27	421	CLSG-40012	193	51	CATG-400
419	469	400	305,0	248,0	114	228	3	27	401	CLSG-5002	228	63	CATG-500
519	669	400	305,0	248,0	114	228	3	27	480	CLSG-5006	228	63	CATG-500
669	969	400	305,0	248,0	114	228	3	27	599	CLSG-50012	228	63	CATG-500
429	479	430	330,0	267,0	114	247	3	27	474	CLSG-6002	241	76	CATG-600
529	679	430	330,0	267,0	114	247	3	27	565	CLSG-6006	241	76	CATG-600
679	979	430	330,0	267,0	114	247	3	27	701	CLSG-60012	241	76	CATG-600
474	524	505	387,0	317,0	149	297	3	27	741	CLSG-8002	287	75	CATG-800
574	724	505	387,0	317,0	149	297	3	27	880	CLSG-8006	287	75	CATG-800
724	1024	505	387,0	317,0	149	297	3	27	1058	CLSG-80012	287	75	CATG-800
564	614	560	432,0	343,0	174	323	3	27	1062	CLSG-10002	311	93	CATG-1000
664	814	560	432,0	343,0	174	323	3	27	1213	CLSG-10006	311	93	CATG-1000
814	1114	560	432,0	343,0	174	323	3	27	1439	CLSG-100012	311	93	CATG-1000