

The Drive & Control Company

**Rexroth**  
Bosch Group

## External control electronics for the SYDFE1 control of the A10VSO axial piston variable displacement pump

Type VT 5041

**RE 30242**

Edition: 2013-06

Replaces: 12.11

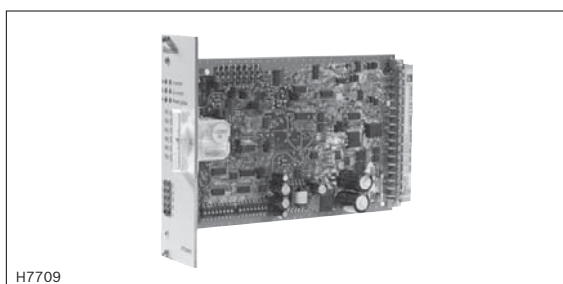

- ▶ Component series 3X
- ▶ Analog, Euro-card format
- ▶ Part of the SYDFE1 pressure and flow control system (component series 1X, 2X and 3X) for the control of the axial piston variable displacement pump A10VSO... with SYDFE1 control via valve VT-DFP...2X

### Features

- ▶ Implementation of the electronic functions of the SYDFE1 control; pressure and swivel angle control; optional power limitation
- ▶ Pressure controller circuitry can be adjusted and switched to two existing hydraulic fluid volumes (actuators plus lines)
- ▶ Differential amplifier inputs
- ▶ Controller for valve spool position
- ▶ Minimum value generator for pressure and swivel angle controller
- ▶ Self-timed output stage
- ▶ Pressure-dependent leakage compensation (can be switched off)
- ▶ Reverse polarity protection for voltage supply
- ▶ Switchable actual pressure value input (current, voltage, range)
- ▶ 6 LED displays on the front plate for the operating state
- ▶ Display instrument on the front plate for actual swivel angle value (optional)
- ▶ Power limitation with internal or external command value presetting (optional)

### Contents

Features	1
Ordering codes	2
Functional description	3
Block diagram/pin assignment	4
Technical data	6
Electronic card: Display and adjustment elements	8
Front plate: Display and adjustment elements, measuring sockets	9
Dimensions	10

Bosch Rexroth AG, RE 30242, edition: 2013-06

2/10 VT 5041 | Control electronics

## Ordering codes

01	02	03	04
VT 5041	-	3X	/
			-
			0

01	External control electronics for the SYDFE1 control of the A10VSO axial piston variable displacement pump	VT 5041
02	Component series 30 to 39 (30 to 39: Unchanged technical data and pin assignment)	3X

### Additional functions

03	Without power limitation/without display instrument	1
	Without power limitation/with display instrument	2
	With power limitation/with display instrument	3
04	For IW9 swivel angle sensor (standard)	0

## Preferred types

Material no.	Type
R901236404	VT 5041-3X/1-0
R901263598	VT 5041-3X/2-0
R901196678	VT 5041-3X/3-0

## Recommended accessories

### Card holder:

- ▶ Open card holder VT 3002-1-2X/32D  
(see data sheet 29928)

### Power supply unit:

- ▶ Type VT-NE32-1X, see data sheet 29929  
Compact power supply unit 115/230 VAC → 24 VDC
  - Output 1 (60 W) for VT-5041 supply
  - Output 2 (24 W) for the supply of pressure transducers; e.g. type HM 12 or HM 13, see data sheet 29933

## Functional description

The analog control electronics VT5041-3X/... is designed as insertion card in euro format. It is provided with a command value input each for pressure and swivel angle [1] as a standard (optional power limitation). The actual pressure value is measured with a pressure transducer. The position transducer at the pump measures the actual swivel angle value. The measured actual values are processed in amplifier [2] and [3] and compared with the provided command values. The minimum value generator [4] controls that only controller [6] or [10] which is allocated to the requested operating point is automatically activated. The output signal of the minimum value generator [4] becomes the command value for the valve control loop.

The optionally available power limitation is automatically activated by the provision of a suitable command value. The power command value can be provided internally or externally. If necessary, it limits the swivel angle command value by means of a minimum value generator [5]. The resulting swivel angle command value can be measured at socket 7.

The actual valve value (position of the valve spool) is measured with an inductive position transducer. An oscillator/demodulator switch [7] enhances the signal. The control deviation is generated and processed in the controller for the valve spool position [8]. The output signal of the valve controller [8] forms the command value for the self-timing power output stage [9] which controls the proportional solenoid of the valve.

The control electronics is equipped with a fault message output where a voltage of 0 V is applied in case of error (= low-active). At the same time, the "Err." LED flashes. Depending on the jumper J1 configuration, the valve output can be de-energized in case of an error message.

Causes for error messages:

- ▶ Defective internal voltage supply
  - ▶ The actual pressure value is greater than the admissible system pressure (socket 2:  $p_{act} > 11.5 \text{ V}$ )
  - ▶ No enable signal at port 26c
  - ▶ Cable break or range of the swivel angle return exceeded
  - ▶ Cable break or range of the valve spool return exceeded
  - ▶ Cable break "pressure transducer" (for adjustments 4...20 mA, 0.5...5 V and 1...10 V)
  - ▶ Control error (control difference x controller amplification) is greater than 4 V (40%) for more than 1 second
- In case of error, the electronics can be configured so that the output stage is de-energized and the valve spool is pressed to its mechanical end position. This causes the pump to swivel back. The error can only be acknowledged by resetting the enable signal.

[ ] = assignment to the block diagram on page 4 and 5

4/10 VT 5041 | Control electronics

## Block diagram/pin assignment

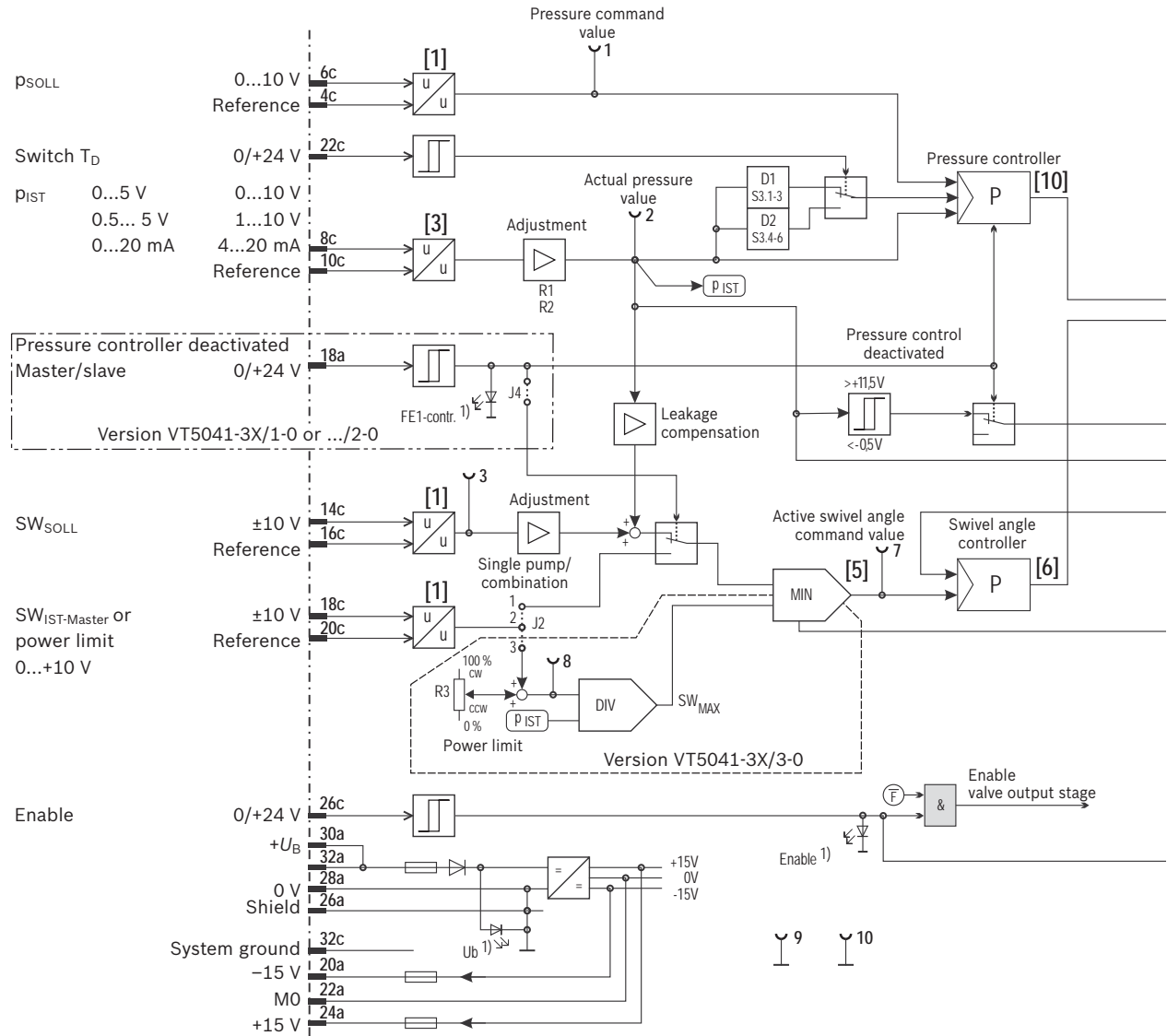

### Abbreviations for the signals

PSOLL	Pressure command value
P <sub>IST</sub>	Actual pressure value
Switch T <sub>D</sub>	Oil volume selection
SW <sub>SOLL</sub>	Swivel angle command value
SW <sub>IST</sub>	Actual swivel angle value
SW <sub>IST-Master</sub>	Actual master swivel angle value
FE1 contr.	Pressure controller disabled

For the function of the jumpers and switches on the electronic card see page 8.

For the meaning of the measuring sockets, and display and adjustment elements (potentiometer) on the front plate, see page 9.

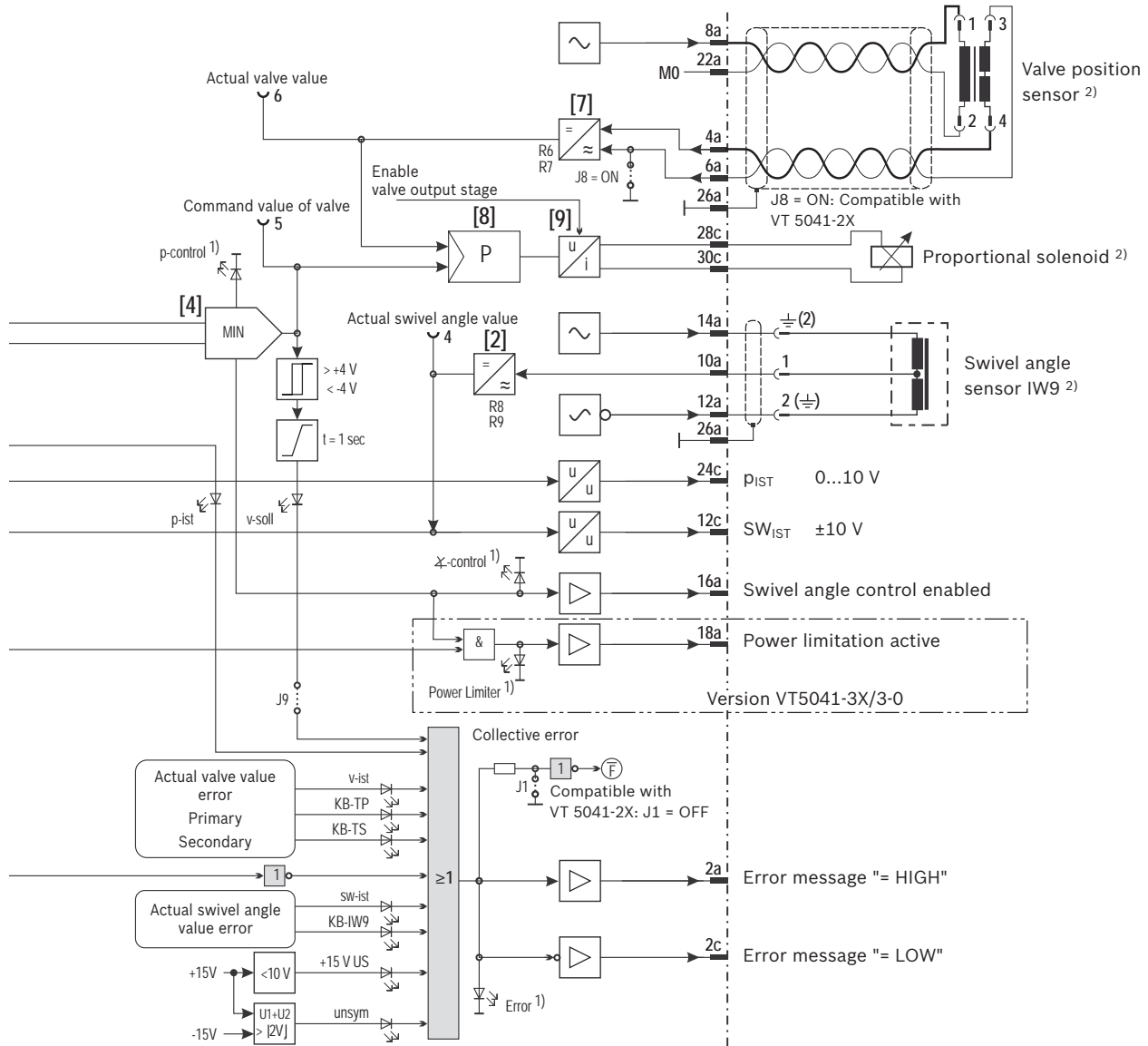

### Diagnostic LEDs on the printed circuit board

v-soll	Persisting control deviation is too great
v-ist	Actual valve value error - exceeding of range
p-ist	Actual pressure value error
sw-ist	Actual swivel angle value error - exceeds range
KB-TP	Valve position sensor cable break - primary
KB-TS	Valve position sensor cable break - secondary
KB-IW9	Swivel angle position sensor cable break
+15 V US	+15 V undervoltage (internal power supply unit)
unsym	Internal voltage supply is asymmetric

- 1) LED displays on the front plate (for meaning see page 9)
- 2) For further information with regard to the connection, see operating instructions 30011-B

6/10 VT 5041 | Control electronics

## Technical data (for applications outside these parameters, please consult us.)

Operating voltage	$U_B$	24 V DC + 40 -10% (21.6... 33.6 V)
Upper limit value	$u_B(t)_{max}$	35 V
Lower limit value	$u_B(t)_{min}$	21 V
Current consumption	$I_{rated} (I_{max})$	0.6 A (1.25 A)
Analog command value inputs		
Pressure $p_{SOLL}$	$U_e$	0...10 V; $R_e > 50 \text{ k}\Omega$
Swivel angle $SW_{SOLL}$	$U_e$	Standard $\pm 10 \text{ V}$ ; regenerative: 0...10 V; $R_e > 50 \text{ k}\Omega$
Power ( $p \cdot SW$ ) <sub>max</sub> or $SW_{IST-Master}$	$U_e$	0...10 V, $R_e > 50 \text{ k}\Omega$ $\pm 10 \text{ V}$ , $R_e > 50 \text{ k}\Omega$
Analog actual value inputs		
Pressure $p_{IST}$	$U_e$	0...5 V, 0...10 V; $R_e > 50 \text{ k}\Omega$
	$I_e$	0.5...5 V, 1...10 V; $R_e > 50 \text{ k}\Omega$ 0...20 mA, 4...20 mA; $R_B = 100 \Omega$
Enable input (PLC)	$U_e$	> 12 V
Analog outputs		
Output stage		
Solenoid current	$I_{max}$	2.5 A; $R_{20} = 2 \Omega$
Oscillator		
Frequency	$f$	5.4 kHz
Amplitude for IW9 (actual swivel angle value)	$U_{ss}$	1 V (port 12a /14a)
Amplitude for DM2 (actual valve value)	$U_{ss}$	3.6 V (port 8a)
Signal voltage outputs		
Actual pressure value	$U$	0...10 V
Actual swivel angle value	$U$	-10 V... +10 V $\pm$ -100%... +100%
Auxiliary voltages for external use	$U$	$\pm(15 \text{ V} + 2\% - 6\%)$ ; $I_{max} = 10 \text{ mA}$
Measuring sockets, function and number		
Pressure command value ( $p_{SOLL}$ )	1	$U$ 0... 10 V $\pm$ 0... +100%; $R_i = 2 \text{ k}\Omega$
Actual pressure value ( $p_{IST}$ )	2	$U$ 0... 10 V $\pm$ 0... +100%; $R_i = 2 \text{ k}\Omega$
Swivel angle command value ( $SW_{SOLL}$ )	3	$U$ $\pm 10 \text{ V} \pm \pm 100\%$ ; $R_i = 2 \text{ k}\Omega$
Actual swivel angle value ( $SW_{IST}$ )	4	$U$ $\pm 10 \text{ V} \pm \pm 100\%$ ; $R_i = 2 \text{ k}\Omega$
Valve command value ( $x_{V_{soll}}$ )	5	$U$ $\pm 10 \text{ V} \pm \pm 100\%$ ; $R_i = 2 \text{ k}\Omega$
Actual valve value ( $x_{V_{ist}}$ )	6	$U$ $\pm 10 \text{ V} \pm \pm 100\%$ ; $R_i = 2 \text{ k}\Omega$
Active swivel angle command value	7	$U$ $\pm 10 \text{ V} \pm \pm 100\%$ ; $R_i = 2 \text{ k}\Omega$
Power limit ( $P_{max}$ )	8	$U$ 0... +10 V $\pm$ 0... +100%; $R_i = 2 \text{ k}\Omega$
Reference	9 and 10	
Message outputs		
Swivel angle control enabled	$U$	$U_B - 3 \text{ V}$ ( $I_{max} = 20 \text{ mA}$ )
Power limitation active	$U$	$U_B - 3 \text{ V}$ ( $I_{max} = 20 \text{ mA}$ )
Error messages		
Low-active	$U$	$U_B - 3 \text{ V}$ ( $I_{max} = 20 \text{ mA}$ ); error at $U < 1 \text{ V}$
High-active	$U$	$U_B - 3 \text{ V}$ ( $I_{max} = 20 \text{ mA}$ )
Type of sensor		
Swivel angle		
IW9 (inductive position transducer)		Throttle circuit; $\pm 4 \text{ mm}$ ; 3-conductor connection
Valve		
DM2 (inductive position transducer)		Transformer circuit; $\pm 0.6 \text{ mm}$ ; 4-conductor connection

Bosch Rexroth AG, RE 30242, edition: 2013-06

**Technical data** (for applications outside these parameters, please consult us.)

Type of connection	
Compatibility	32 pin male multipoint connector; DIN 41612; design D
Card dimensions	Euro-card 100 x 160 mm; DIN 41494
Front plate dimensions	
Height	3 HE (128.4 mm)
Conductor path side width	1 TE
Component side width	
VT 5041-3X/1-0	5 TE
VT 5041-3X/2-0 and VT 5041-3X/3-0	7 TE
Operating temperature range	<b>9</b> 0... +50 °C
Storage temperature range	<b>9</b> -20... +70 °C
Weight	
Electronic card without display	m 0.19 kg
Electronic card with display	m 0.21 kg

8/10 VT 5041 | Control electronics

## Electronic card: Display and adjustment elements

Leakage compensation	Jumpers	
	J6	J7
Off	OFF	OFF
4%	OFF	ON
6%	ON	OFF
10%	ON	ON

Valve command value monitoring	Jumpers	
	J9	
On	ON	
Off *	OFF	

Diagnostic LEDs		
For a description, see page 5 and the operating instructions 30011-B		

Regenerative operation	Jumpers	
	J3	J5
On	ON	OFF
Off	OFF	ON

Function pin 18a **	Jumpers	
	J4	
Pressure control on/off	OFF	
Master/slave on/off	ON	

\*\* Only for versions without power limitation (VT 5041-3X/1-0 und VT 5041-3X/2-0)

Valve deactivation in case of error	Jumpers	
	J1	
Active	OFF *	
Inactive	ON	

\* Compatible with VT 5041-2X

Volume adjustment of pressure controller			
Input switch T <sub>D</sub> = OFF	Switch S3		
	.1	.2	.3
≤ 5.0 l	OFF	OFF	OFF
7.5 l	OFF	ON	OFF
10.0 l	ON	ON	OFF
15.0 l	ON	OFF	ON
20.0 l	OFF	ON	ON
25.0 l	ON	ON	ON

Input switch T <sub>D</sub> = ON	Switch S3		
	.4	.5	.6
12.5 l	OFF	OFF	OFF
30.0 l	OFF	ON	OFF
45 l	ON	ON	OFF
60 l	ON	OFF	ON
75 l	OFF	ON	ON
90 l	ON	ON	ON

Selection for analog input at pin 18c	Jumpers	
	J2	Bridge
Actual master swivel angle value	1-2	
External power limitation	2-3	

Pressure controller p amplification	Switch S3		Jumpers
	.7	.8	
8.0	OFF	OFF	OFF
4.8	OFF	ON	OFF
4.0	OFF	OFF	ON
3.0	OFF	ON	ON
2.4	ON	OFF	ON
2.0	ON	ON	ON

Actual pressure value amplification	Jumpers	
	J10	
1-fold	OFF	
2-fold	ON	

Signal adjustment of actual pressure value	Switch S2							
	.1	.2	.3	.4	.5	.6	.7	.8
V	0...10 V	OFF	OFF	OFF	OFF	OFF	ON	ON
E	1...10 V	OFF	OFF	OFF	OFF	ON	OFF	ON
D	0...5 V	OFF	OFF	ON	ON	OFF	OFF	ON
F	0.5...5 V	OFF	OFF	ON	ON	ON	OFF	ON
B	0...20 mA	ON	ON	OFF	OFF	OFF	OFF	ON
C	4...20 mA	ON	ON	OFF	OFF	ON	ON	OFF

Explanations:  
ON = bridge closed  
OFF = bridge open  
[Shaded] = factory setting

For the meaning of the measuring sockets, and display and adjustment elements (potentiometer) on the front plate, see page 9.

Bosch Rexroth AG, RE 30242, edition: 2013-06

## Front plate: Display and adjustment elements, measuring sockets

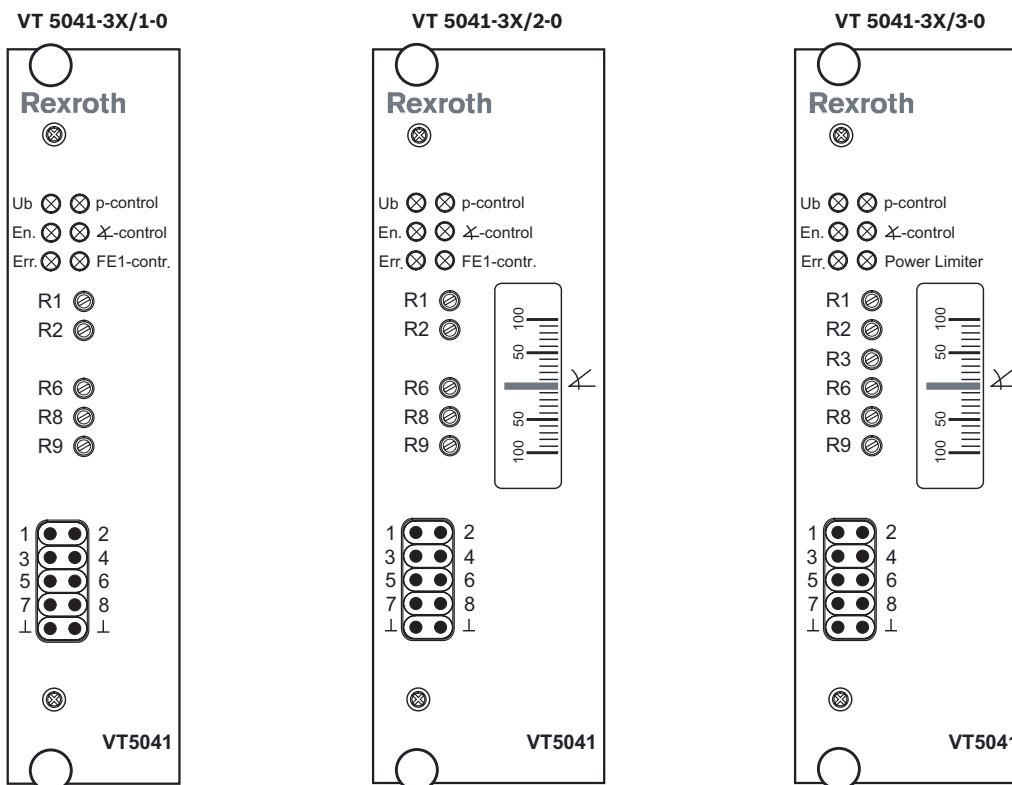

### LED displays

Ub (green)	Supply voltage available
En. (green)	Enable available
Err. (red)	Fault/collective error
p-control (yellow)	Pressure control enabled
∠-control (yellow)	Swivel angle control enabled
FE1 contr. (yellow)	Pressure controller disabled
Power Limiter (yellow)	Power limitation active

### Adjustment elements (potentiometer)

R1	Zero point of actual pressure value
R2	Actual pressure value amplification
R3	Setting of the power limit
R6	Zero point of actual valve value
R8	Zero point of actual swivel angle value
R9	Amplification of actual swivel angle value

### Measuring sockets (R<sub>i</sub> = 2 kΩ)

1	Pressure command value 0...+10 V
2	Actual pressure value 0...+10 V
3	Swivel angle command value ±10 V
4	Actual swivel angle value ±10 V
5	Valve command value ±10 V
6	Actual valve value ±10 V
7	Active swivel angle command value ±10 V
8	Power limit 0...+10 V
⊥	Reference for measured values
⊥	Reference for measured values

### Display (measuring instrument)

∠	Display of actual swivel angle value in %
---	---

10/10 VT 5041 | Control electronics

## Dimensions (dimensions in mm)

VT 5041-3X/1-0 VT 5041-3X/3(2)-1

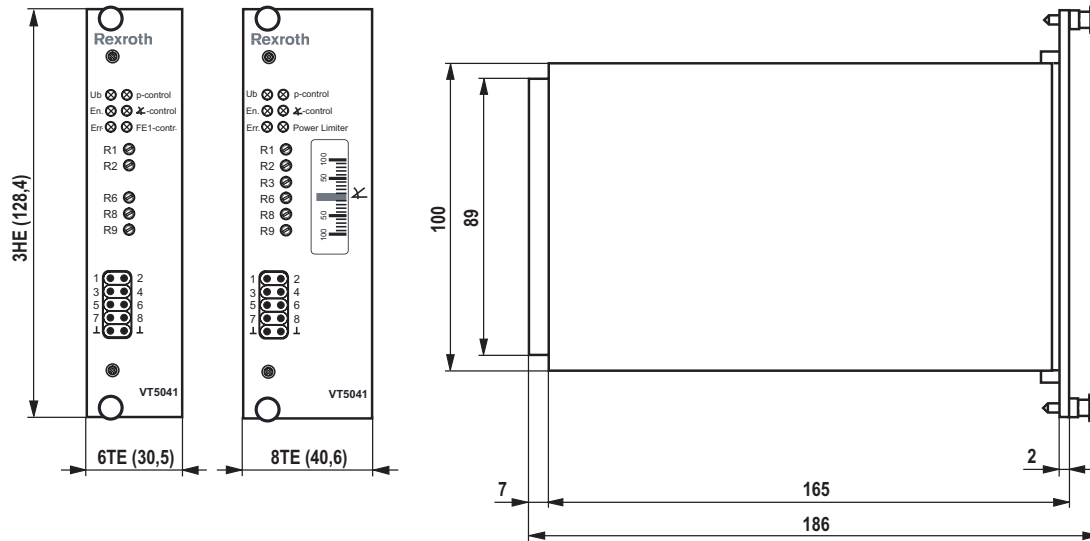

© This document, as well as the data, specifications and other information set forth in it, are the exclusive property of Bosch Rexroth AG. It may not be reproduced or given to third parties without its consent.

The data specified above only serve to describe the product. No statements concerning a certain condition or suitability for a certain application can be derived from our information. The information given does not release the user from the obligation of own judgment and verification. It must be remembered that our products are subject to a natural process of wear and aging.

Bosch Rexroth AG, RE 30242, edition: 2013-06