

Electric Drives
and Controls

Hydraulics

Linear Motion and
Assembly Technologies

Pneumatics

Service

Rexroth
Bosch Group

Hydraulic cylinders Mill type design

RE 17329/10.07 1/68
Replaces: 09.07
17328

Series CDM1 / CGM1 / CSM1

Component series 2X
Nominal pressure 160 bar (16 MPa)



H4652

Table of contents

Contents	Page	Contents	Page
Features	1	Piston rod end "E"	40
Technical data	2	Connections, subplates for valve mounting	40 to 45
Engineering notes ICS	2	Accessories	46 to 54
Diameters, areas, forces, flow	3	Buckling, permissible stroke length	55, 56
Tolerances according to ISO 8135	3	End position cushioning, calculation example	57, 58
Overview of mounting elements, ordering code for series CDM1 and CGM1	4 to 7	Bleeding, throttle valve	59
Mounting types	8 to 23	Seal (piston rod/piston)	60
Proximity switches	24, 25	Spare parts	61 to 64
Overview of mounting elements, ordering code, general notes on series CSM1	26, 27	Seal kits	65, 66
Mounting types	28 to 37	Tightening torques	67
Position measuring system	38, 39	Cylinder weight	68

Features

- Installation dimensions to ISO 6020/1, NF E 48-015 and VW 39 D 920
- 9 mounting types
- Piston Ø 25 to 200 mm
- Piston rod Ø 14 to 140 mm
- Stroke lengths up to 3000 mm
- Self-adjusting and adjustable end position cushioning

Technical data (for applications outside these parameters, please consult us!)

Standards:

The installation dimensions and mounting types of the cylinders comply with standards ISO 6020/1, NF E 48-015 and VW 39 D 920

Nominal pressure: 160 bar (16 MPa)

Static test pressure: 240 bar (24 MPa)

Higher operating pressures up to 200 bar on request.

In the case of extreme shock loads, the mounting elements and threaded piston rod connections must be rated for endurance strength.

Minimum pressure:

Depending on the application, a certain minimum pressure is required to ensure proper operation of the cylinder. If no load is applied, we recommend a minimum pressure of 10 bar for single-rod cylinders; for lower pressures and double rod cylinders, please consult us.

Installation position: Optional

Hydraulic fluid:

Mineral oils DIN 51524 (HL, HLP)

Phosphate ester (HFD-R)

Water glycol HFC on request

Hydraulic fluid temperature range: -20 °C to +80 °C

Ambient temperature range: -20 °C to +80 °C

Viscosity range: 2.8 to 380 mm²/s

Cleanliness class to ISO

Permissible maximum degree of contamination of the hydraulic fluid to ISO 4406 (c) class 20/18/15.

Stroke velocity: Up to 0.5 m/s
(depending on pipe connection)

Vent as a standard

Primer coating:

As a standard, hydraulic cylinders are primed with one coating (colour: gentian blue, RAL 5010) in a thickness max. 80 µm.

Service life:

Rexroth cylinders fulfill the reliability recommendations for industrial applications.
≥ 10 000 000 double strokes in continuous off-load operation or 3000 km of stroke travel at 70% of the maximum operating pressure without loading of the piston rod at a maximum velocity of 0.5 m/s, with a failure rate of less than 5%.

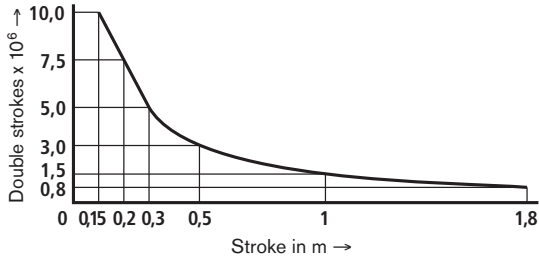

Acceptance:

Each cylinder is tested according to Bosch Rexroth standard.

Safety notes:

For assembly, commissioning and maintenance cylinders, please take the operating guidelines stated in RE 07100-B into account!

Service and repair work may only be carried out by Bosch Rexroth AG and specifically trained personnel. No warranty claims will be accepted for damage resulting from assembly, maintenance and repair work not carried out by Bosch Rexroth AG.

Checklists for hydraulic cylinders:

Cylinders, the technical and/or operating data of which differ from the parameters given in the data sheet, can only be offered as special variants on request. For the preparation of offers, deviations of technical data and/or operating data must be described in the checklists for hydraulic cylinders (RE 07200).

Engineering software ICS (Interactive Catalog System)

The ICS (Interactive Catalog System) is a selection and engineering aid for hydraulic cylinders. With the help of the ICS, designers of plant and machinery can quickly and reliably find the optimum hydraulic cylinder solution through logic-guided type code queries. This software helps to solve design and engineering tasks more quickly and efficient. After having been

guided through the product selection, the user gets the exact technical data of the selected components as well as 2D and 3D CAD data in the correct file format for all common CAD systems quickly and reliably.

This allows users to reduce costs while increasing their competitiveness.

Diameters, areas, forces, flow

Piston AL Ø mm	Piston rod MM Ø mm	Area ratio φ A_1/A_3	Areas			Force at 160 bar ¹⁾			Flow at 0.1 m/s ²⁾		
			Piston A_1 cm ²	Rod A_2 cm ²	Annulus A_3 cm ²	Pressure F_1 kN	Diff. F_2 kN	Pulling F_3 kN	Out q_{V1} l/min	Diff. q_{V2} l/min	In q_{V3} l/min
25	14	1.46	4.91	1.54	3.37	7.85	2.44	5.37	2.9	0.9	2.0
	18	2.08		2.54							
32	18	1.46	8.04	2.54	5.50	12.80	4.07	8.78	4.8	1.5	3.3
	22	1.90		3.80							
40	22	1.43	12.56	3.80	8.76	20.00	6.08	14.03	7.5	2.3	5.2
	28	1.96		6.16							
50	28	1.46	19.63	6.16	13.47	31.30	9.82	21.55	11.8	3.7	8.1
	36	2.08		10.18							
63	36	1.48	31.17	10.18	20.99	49.80	16.29	33.56	18.7	6.1	12.6
	45	2.04		15.90							
80	45	1.46	50.26	15.90	34.36	80.30	25.40	54.96	30.2	9.5	20.7
	56	1.96		24.63							
100	56	1.46	78.54	24.63	53.91	125.00	39.30	86.22	47.1	14.8	32.3
	70	1.96		38.48							
125	70	1.46	122.72	38.48	84.24	196.00	61.50	134.7	73.6	23.1	50.5
	90	2.08		63.62							
160	90	1.46	201.06	63.62	137.44	321.00	101.00	219.8	120.6	38.2	82.4
	110	1.90		95.06							
200	110	1.43	314.16	95.06	219.09	502.60	152.00	350.6	188.5	57.0	131.5
	140	1.96		153.96							

¹⁾ Theoretical force
(without consideration of efficiency)

²⁾ Stroke velocity

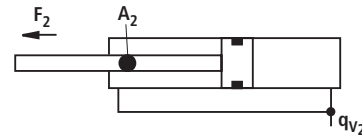
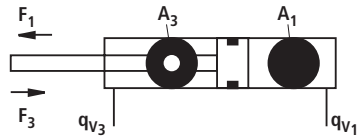

Tolerances according to ISO 8135: 1999E

Installation dimensions	WF	W	WC	XC ¹⁾	XO ¹⁾	XS	SS	XV	ZF ¹⁾	ZP ¹⁾	Stroke tolerances in mm
Mounting type	M00	MF1	MF3	MP3	MP5	MS2	MS2	MT4	MF2	MF4	
Stroke length in mm	Tolerances in mm										
≤ 1250	± 2	± 2	± 2	± 1,5	± 1,5	± 2	± 1,5	± 2	± 1,5	± 1,5	+ 2
> 1250 bis ≤ 3000	± 4	± 4	± 4	± 3	± 3	± 4	± 3	± 4	± 3	± 3	+ 5

¹⁾ Stroke length included

Overview of mounting elements: Series CDM1

CDM1 M00
See pages 8, 9



CDM1 MP3
See pages 10, 11



CDM1 MF1
See pages 12, 13



CDM1 MP5
See pages 10, 11



CDM1 MF2
See pages 14, 15



CDM1 MT4
See pages 20, 21



CDM1 MF3
See pages 16, 17



CDM1 MS2
See pages 22, 23



CDM1 MF4
See pages 18, 19



Ordering code

- ²⁾ = Only available on request
- ³⁾ = Piston Ø 25 to 125 mm
- ⁴⁾ = Always specify dimension "XY" in mm in clear text on the order
- ⁵⁾ = Piston Ø 63 to 200 mm
- ⁶⁾ = Not for MF2; MF4
- ⁷⁾ = Piston Ø 50 to 200 mm
- ⁸⁾ = Piston Ø 40 to 200 mm
- ⁹⁾ = Piston Ø 40 to 80 mm, only position 11
- ¹⁰⁾ = Piston Ø 63 to 200 mm, only position 11
- ¹¹⁾ = Piston Ø 125 to 200 mm, only position 11
- ¹²⁾ = Piston rod Ø 14 to 110 mm
- ¹³⁾ = Piston rod Ø 22 to 140 mm
- ¹⁴⁾ = Subplates only possible with pipe thread (ISO 1179-1)

- ¹⁶⁾ = Subplates for SL and SV valves (isolator valves)
Note: Seal variants T and S are not rated for static holding function!
- ¹⁷⁾ = Per piston Ø, only possible with large piston rod Ø

Order examples:

CDM1MT4/50/28/550A2X/B11CGDMWW,
XV = 175 mm
CDM1MF3/200/140/950A2X/B11CHKAWW

Remark

Spare cylinder for series 1X

When changing over to series 2X, the bearing blocks (trunnion) must be changed as well!

Overview of mounting elements: Series CGM1

CGM1 MF1

See pages 12, 13



CGM1 MF3

See pages 16, 17



CGM1 MT4

See pages 20, 21



CGM1 MS2

See pages 22, 23



Ordering code

- ¹⁾ = Not standardised
- ³⁾ = Piston Ø 25 to 125 mm
- ⁴⁾ = Always specify dimension "XY" in mm in clear text on the order
- ⁵⁾ = Piston Ø 63 to 200 mm
- ⁷⁾ = Piston Ø 50 to 200 mm
- ⁸⁾ = Piston Ø 40 to 200 mm
- ⁹⁾ = Piston Ø 40 to 80 mm, only position 11
- ¹⁰⁾ = Piston Ø 63 to 200 mm, only position 11
- ¹¹⁾ = Piston Ø 125 to 200 mm, only position 11
- ¹²⁾ = Piston rod Ø 14 to 110 mm
- ¹⁴⁾ = Subplates only possible with pipe thread ISO 1179-1
- ¹⁶⁾ = Subplates for SL and SV valves (isolator valves)
Note: Seal variants T and S are not rated for static holding function!
- ¹⁷⁾ = Per piston Ø, only possible with large piston rod Ø

Mounting type M00

CDM1 M00

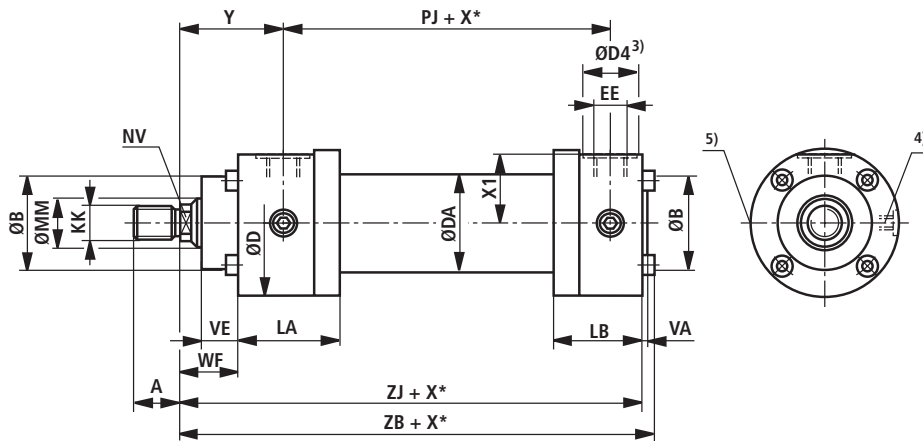

CDM1 M00...2X/...A: as chevron seal variant and AL Ø 50 - 200 mm

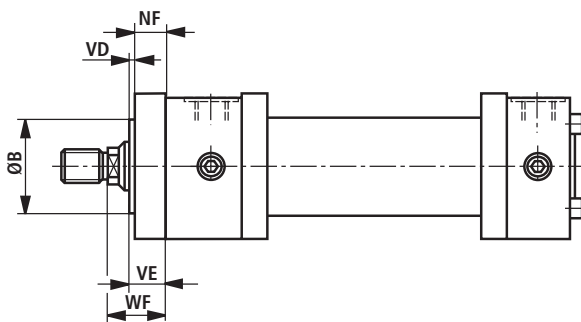

Dimensions M00 (dimensions in mm)

AL Ø	MM Ø	KK ¹⁾ ISO 6020/1	A ¹⁾	KK ²⁾ VW 39 D 920	A ²⁾	NV	ØB f8	ØD	ØDA	ØD4 3); 8)	EE 8)	ØD4 3); 9)	EE 9)
25	14 18	M12x1.25 M14x1.5	16 18	– M12x1.25	– 16	12 14	32	56	35	25	G1/4	21	M14x1.5
32	18 22	M14x1.5 M16x1.5	18 22	– M14x1.5	– 18	14 18	40	67	42	28	G3/8	26	M18x1.5
40	22 28	M16x1.5 M20x1.5	22 28	– M16x1.5	– 22	18 22	50	78	50	34	G1/2	29	M22x1.5
50	28 36	M20x1.5 M27x2	28 36	– M20x1.5	– 28	22 30	60	95	60	34	G1/2	29	M22x1.5
63	36 45	M27x2 M33x2	36 45	– M27x2	– 36	30 36	70	116	78	42	G3/4	34	M27x2
80	45 56	M33x2 M42x2	45 56	– M33x2	– 45	36 46	85	130	95	42	G3/4	34	M27x2
100	56 70	M42x2 M48x2	56 63	– M42x2	– 56	46 60	106	158	120	47	G1	43	M33x2
125	70 90	M48x2 M64x3	63 85	– M48x2	– 63	60 75	132	192	150	47	G1	43	M33x2
160	90 110	M64x3 M80x3	85 95	– M64x3	– 85	75 95	160	237	190	58	G1 1/4	52	M42x2
200	110 140	M80x3 M100x3	95 112	– M80x3	– 95	95 120	200	285	230	58	G1 1/4	52	M42x2

AL Ø	MM Ø	Y	PJ	X1	VA	VE	VD	NF	WF	ZB	ZJ	LA	LB
25	14 18	58	77	26	3	15	–	–	28	156	150	58	43
32	18 22	64	89	30.5	3	19	–	–	32	176	170	62	47
40	22 28	71	97	35.5	3	19	–	–	32	196	190	73	56
50	28 36	72	111	44.5	4	24	4	20	38	213	205	74	62
63	36 45	82	117	54.5	4	29	4	25	45	234	224	84	72
80	45 56	91	134	62.5	4	36	4	32	54	260	250	93	81
100	56 70	108	162	75.5	5	37	5	32	57	310	300	117	96
125	70 90	121	174	92.5	5	37	5	32	60	335	325	143	112
160	90 110	143	191	115.5	8	41	5	36	66	380	370	171	130
200	110 140	190	224	138.5	15	45	5	40	75	466	450	230	151

AL = Piston Ø MM = Piston rod Ø

X* = Stroke length

1) = Thread for piston rod end "G" and "K"

2) = Thread for piston rod end "H" and "F"

3) = ØD4 countersink max. 0.5 mm deep

4) = Bleeding: When viewed to the piston rod, the position is by 90° offset in relation to the pipe connection (clockwise)

5) = Throttle valve only with end position cushioning "E" (180° for bleeding)

8) = Pipe connection "B"

9) = Pipe connection "R"

Dimensions MP3/MP5 (dimensions in mm)

AL	MM	KK ¹⁾	A ¹⁾	KK ²⁾	A ²⁾	NV	ØB	ØD	ØDA	ØD4	EE	ØD4	EE	Y	PJ
Ø	Ø	ISO 6020/1		VW 39 D 920			f8			3); 8)	8)	3); 9)	9)		
25	14 18	M12x1.25 M14x1.5	16 18	- M12x1.25	- 16	12 14	32	56	35	25	G1/4	21	M14x1.5	58	77
32	18 22	M14x1.5 M16x1.5	18 22	- M14x1.5	- 18	14 18	40	67	42	28	G3/8	26	M18x1.5	64	89
40	22 28	M16x1.5 M20x1.5	22 28	- M16x1.5	- 22	18 22	50	78	50	34	G1/2	29	M22x1.5	71	97
50	28 36	M20x1.5 M27x2	28 36	- M20x1.5	- 28	22 30	60	95	60	34	G1/2	29	M22x1.5	72	111
63	36 45	M27x2 M33x2	36 45	- M27x2	- 36	30 36	70	116	78	42	G3/4	34	M27x2	82	117
80	45 56	M33x2 M42x2	45 56	- M33x2	- 45	36 46	85	130	95	42	G3/4	34	M27x2	91	134
100	56 70	M42x2 M48x2	56 63	- M42x2	- 56	46 60	106	158	120	47	G1	43	M33x2	108	162
125	70 90	M48x2 M64x3	63 85	- M48x2	- 63	60 75	132	192	150	47	G1	43	M33x2	121	174
160	90 110	M64x3 M80x3	85 95	- M64x3	- 85	75 95	160	237	190	58	G1 1/4	52	M42x2	143	191
200	110 140	M80x3 M100x3	95 112	- M80x3	- 95	95 120	200	285	230	58	G1 1/4	52	M42x2	190	224

AL	MM	X1	VE	WF	NF	VD	XC/XO	CD/CX	EP	EW/EX	L/LT	MR/MS	LA	LD	L1	Z
Ø	Ø							H9/H7		h12						
25	14 18	26	15	28	-	-	178	12	11	12	25	16	58	46	6	2°
32	18 22	30.5	19	32	-	-	206	16	13	16	33	20	62	50	6	2°
40	22 28	35.5	19	32	-	-	231	20	17	20	38	25	73	59	6	2°
50	28 36	44.5	24	38	20	4	257	25	22	25	48	32	74	66	8	2°
63	36 45	54.5	29	45	25	4	289	32	27	32	61	40	84	76	10	4°
80	45 56	62.5	36	54	32	4	332	40	32	40	78	50	93	85	10	4°
100	56 70	75.5	37	57	32	5	395	50	40	50	90	63	117	101	10	4°
125	70 90	92.5	37	60	32	5	428	63	52	63	98	71	143	117	12	4°
160	90 110	115.5	41	66	36	5	505	80	66	80	127	90	171	138	12	4°
200	110 140	138.5	45	75	40	5	615	100	84	100	150	112	230	166	16	4°

AL = Piston Ø MM = Piston rod Ø

X* = Stroke length

¹⁾ = Thread for piston rod end "G" and "K"

²⁾ = Thread for piston rod end "H" and "F"

³⁾ = ØD4 countersink max. 0.5 mm deep

⁴⁾ = Bleeding: When viewed to the piston rod, the position is by 90° offset in relation to the pipe connection (clockwise)

⁵⁾ = Throttle valve only with end position cushioning "E" (180° for bleeding)

⁶⁾ = Grease nipple cone head form A to DIN 71412

⁸⁾ = Pipe connection "B"

⁹⁾ = Pipe connection "R"

Mounting type MF1

CDM1 MF1

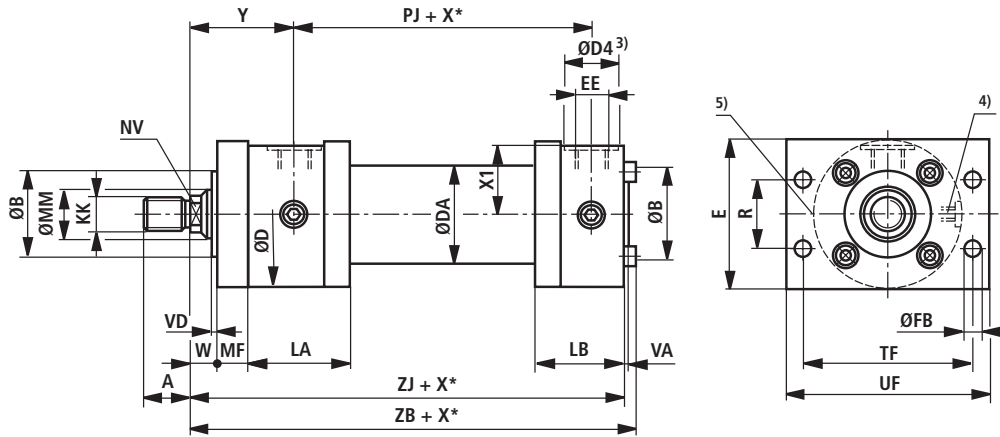

CGM1 MF1

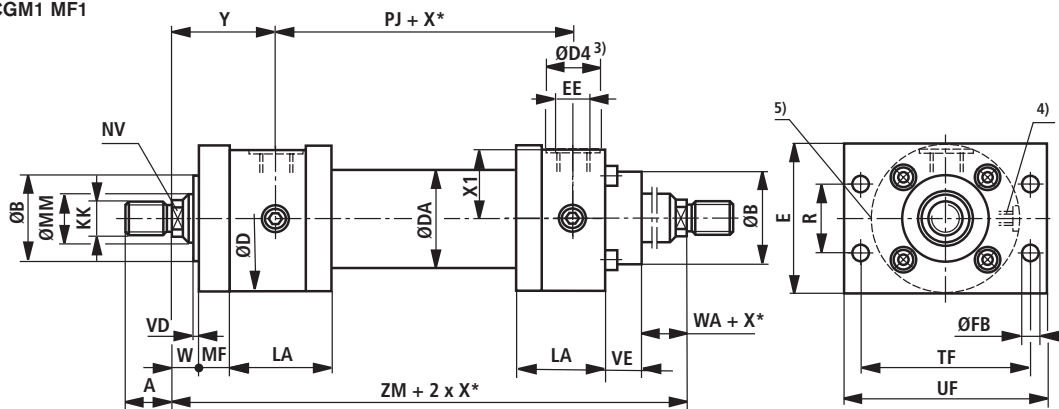

CGM1 MF1..2X/...A: as chevron seal variant and AL Ø 50 - 200 mm

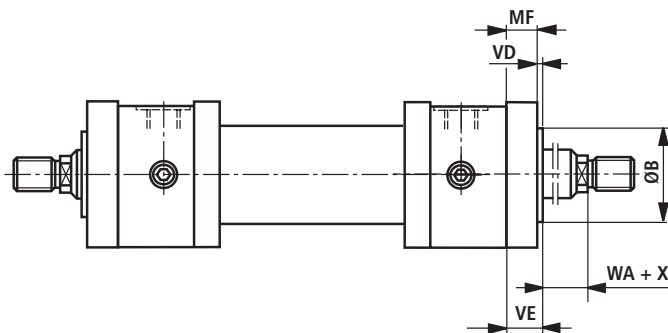

Dimensions MF1 (dimensions in mm)

AL	MM	KK ¹⁾	A ¹⁾	KK ²⁾	A ²⁾	NV	ØB	ØD	ØDA	ØD4	EE	ØD4	EE	Y	PJ	X1
Ø	Ø	ISO 6020/1		VW 39 D 920			f8			3); 8)	8)	3); 9)	9)			
25	14 18	M12x1.25 M14x1.5	16 18	– M12x1.25	– 16	12 14	32	56	35	25	G1/4	21	M14x1.5	58	77	26
32	18 22	M14x1.5 M16x1.5	18 22	– M14x1.5	– 18	14 18	40	67	42	28	G3/8	26	M18x1.5	64	89	30.5
40	22 28	M16x1.5 M20x1.5	22 28	– M16x1.5	– 22	18 22	50	78	50	34	G1/2	29	M22x1.5	71	97	35.5
50	28 36	M20x1.5 M27x2	28 36	– M20x1.5	– 28	22 30	60	95	60	34	G1/2	29	M22x1.5	72	111	44.5
63	36 45	M27x2 M33x2	36 45	– M27x2	– 36	30 36	70	116	78	42	G3/4	34	M27x2	82	117	54.5
80	45 56	M33x2 M42x2	45 56	– M33x2	– 45	36 46	85	130	95	42	G3/4	34	M27x2	91	134	62.5
100	56 70	M42x2 M48x2	56 63	– M42x2	– 56	46 60	106	158	120	47	G1	43	M33x2	108	162	75.5
125	70 90	M48x2 M64x3	63 85	– M48x2	– 63	60 75	132	192	150	47	G1	43	M33x2	121	174	92.5

AL	MM	VE	WA	MF	VA	VD	W	ZJ	ZB	ZM	E	R	TF	UF	ØFB	LA	LB
Ø	Ø											js13	js13		H13		
25	14 18	15	13	12	3	3	16	150	156	193	60	28.7	69.2	85	6.6	58	43
32	18 22	19	13	16	3	3	16	170	176	217	70	35.2	85	105	9	62	47
40	22 28	19	13	16	3	3	16	190	196	239	80	40.6	98	115	9	73	56
50	28 36	24	14	20	4	4	18	205	213	255	100	48.2	116.4	140	11	74	62
63	36 45	29	16	25	4	4	20	224	234	281	120	55.5	134	160	13.5	84	72
80	45 56	36	18	32	4	4	22	250	260	316	135	63.1	152.5	185	17.5	93	81
100	56 70	37	20	32	5	5	25	300	310	378	160	76.5	184.8	225	22	117	96
125	70 90	37	23	32	5	5	28	325	335	416	195	90.2	217.1	255	22	143	112

AL = Piston Ø MM = Piston rod Ø

X* = Stroke length

¹⁾ = Thread for piston rod end "G" and "K"

²⁾ = Thread for piston rod end "H" and "F"

³⁾ = ØD4 countersink max. 0.5 mm deep

⁴⁾ = Bleeding: When viewed to the piston rod, the position is by 90° offset in relation to the pipe connection (clockwise)

⁵⁾ = Throttle valve only with end position cushioning "E" (180° for bleeding)

⁸⁾ = Pipe connection "B"

⁹⁾ = Pipe connection "R"

Mounting type MF2

CDM1 MF2

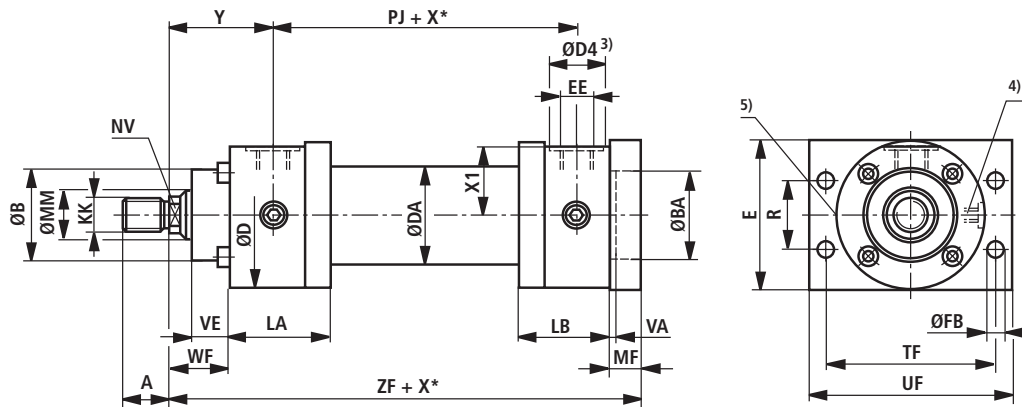

CDM1 MF2..2X/...A: as chevron seal variant and AL $\text{Ø} 50 - 200 \text{ mm}$

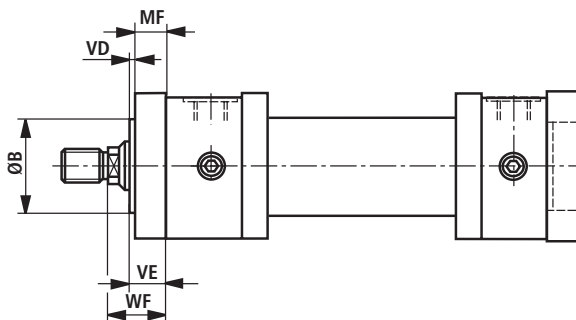

Dimensions MF2 (dimensions in mm)

AL Ø	MM Ø	KK ¹⁾ ISO 6020/1	A ¹⁾	KK ²⁾ VW 39 D 920	A ²⁾	NV	ØB f8	ØD	ØDA	ØD4 3); 8)	EE 8)	ØD4 3); 9)	EE 9)	Y	PJ
25	14 18	M12x1.25 M14x1.5	16 18	- M12x1.25	- 16	12 14	32	56	35	25	G1/4	21	M14x1.5	58	77
32	18 22	M14x1.5 M16x1.5	18 22	- M14x1.5	- 18	14 18	40	67	42	28	G3/8	26	M18x1.5	64	89
40	22 28	M16x1.5 M20x1.5	22 28	- M16x1.5	- 22	18 22	50	78	50	34	G1/2	29	M22x1.5	71	97
50	28 36	M20x1.5 M27x2	28 36	- M20x1.5	- 28	22 30	60	95	60	34	G1/2	29	M22x1.5	72	111
63	36 45	M27x2 M33x2	36 45	- M27x2	- 36	30 36	70	116	78	42	G3/4	34	M27x2	82	117
80	45 56	M33x2 M42x2	45 56	- M33x2	- 45	36 46	85	130	95	42	G3/4	34	M27x2	91	134
100	56 70	M42x2 M48x2	56 63	- M42x2	- 56	46 60	106	158	120	47	G1	43	M33x2	108	162
125	70 90	M48x2 M64x3	63 85	- M48x2	- 63	60 75	132	192	150	47	G1	43	M33x2	121	174

AL Ø	MM Ø	X1	WF	MF	VA	VE	VD	ØBA H8	ZF	E	R js13	TF js13	UF	ØFB H13	LA	LB
25	14 18	26	28	12	3	15	-	32	162	60	28.7	69.2	85	6.6	58	43
32	18 22	30.5	32	16	3	19	-	40	186	70	35.2	85	105	9	62	47
40	22 28	35.5	32	16	3	19	-	50	206	80	40.6	98	115	9	73	56
50	28 36	44.5	38	20	4	24	4	60	225	100	48.2	116.4	140	11	74	62
63	36 45	54.5	45	25	4	29	4	70	249	120	55.5	134	160	13.5	84	72
80	45 56	62.5	54	32	4	36	4	85	282	135	63.1	152.5	185	17.5	93	81
100	56 70	75.5	57	32	5	37	5	106	332	160	76.5	184.8	225	22	117	96
125	70 90	92.5	60	32	5	37	5	132	357	195	90.2	217.1	255	22	143	112

AL = Piston Ø MM = Piston rod Ø

X* = Stroke length

1) = Thread for piston rod end "G" and "K"

2) = Thread for piston rod end "H" and "F"

3) = ØD4 countersink max. 0.5 mm deep

4) = Bleeding: When viewed to the piston rod, the position is 90° offset in relation to the pipe connection (clockwise)

5) = Throttle valve only with end position cushioning "E" (180° for bleeding)

8) = Pipe connection "B"

9) = Pipe connection "R"

Mounting type MF3

CDM1 MF3

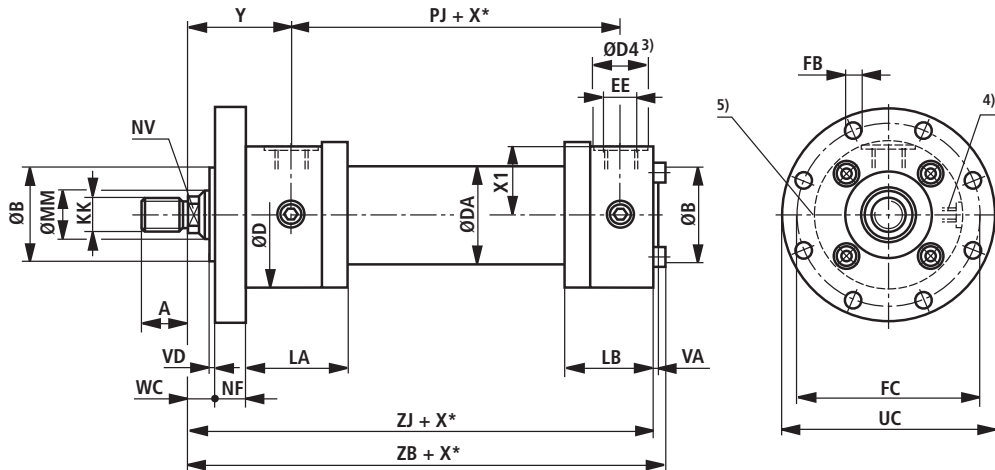

CGM1 MF3

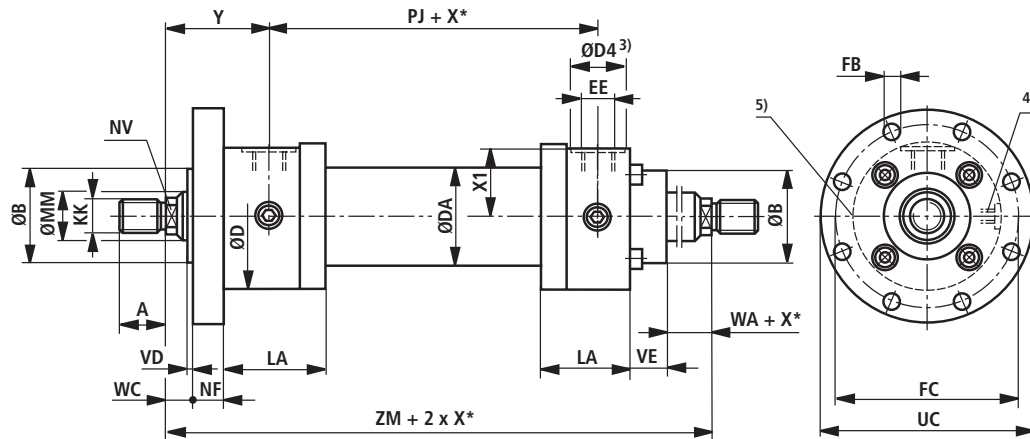

CGM1 MF3..2X/...A: as chevron seal variant and AL Ø 50 - 200 mm

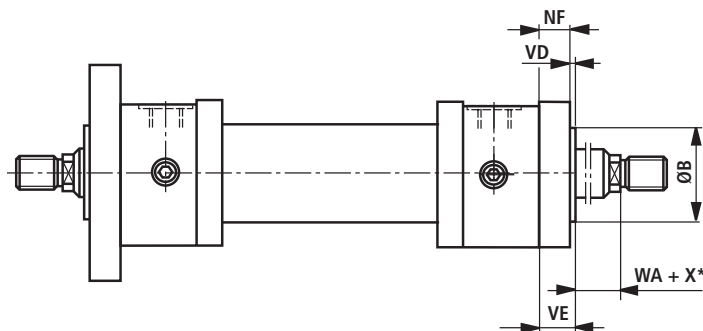

Dimensions MF3 (dimensions in mm)

AL Ø	MM Ø	KK ¹⁾ ISO 6020/1	A ¹⁾	KK ²⁾ VW 39 D 920	A ²⁾	NV	ØB f8	ØD	ØDA	ØD4 3); 8)	EE 8)	ØD4 3); 9)	EE 9)	Y	PJ
25	14 18	M12x1.25 M14x1.5	16 18	- M12x1.25	- 16	12 14	32	56	35	25	G1/4	21	M14x1.5	58	77
32	18 22	M14x1.5 M16x1.5	18 22	- M14x1.5	- 18	14 18	40	67	42	28	G3/8	26	M18x1.5	64	89
40	22 28	M16x1.5 M20x1.5	22 28	- M16x1.5	- 22	18 22	50	78	50	34	G1/2	29	M22x1.5	71	97
50	28 36	M20x1.5 M27x2	28 36	- M20x1.5	- 28	22 30	60	95	60	34	G1/2	29	M22x1.5	72	111
63	36 45	M27x2 M33x2	36 45	- M27x2	- 36	30 36	70	116	78	42	G3/4	34	M27x2	82	117
80	45 56	M33x2 M42x2	45 56	- M33x2	- 45	36 46	85	130	95	42	G3/4	34	M27x2	91	134
100	56 70	M42x2 M48x2	56 63	- M42x2	- 56	46 60	106	158	120	47	G1	43	M33x2	108	162
125	70 90	M48x2 M64x3	63 85	- M48x2	- 63	60 75	132	192	150	47	G1	43	M33x2	121	174
160	90 110	M64x3 M80x3	85 95	- M64x3	- 85	75 95	160	237	190	58	G1 1/4	52	M42x2	143	191
200	110 140	M80x3 M100x3	95 112	- M80x3	- 95	95 120	200	285	230	58	G1 1/4	52	M42x2	190	224

AL Ø	MM Ø	X1	VE	WA	NF	VA	VD	WC	ZJ	ZB	ZM	ØFC js13	ØUC -1	ØFB H13	LA	LB
25	14 18	26	15	13	12	3	3	16	150	156	193	75	90	6.6	58	43
32	18 22	30.5	19	13	16	3	3	16	170	176	217	92	110	9	62	47
40	22 28	35.5	19	13	16	3	3	16	190	196	239	106	125	9	73	56
50	28 36	44.5	24	14	20	4	4	18	205	213	255	126	150	11	74	62
63	36 45	54.5	29	16	25	4	4	20	224	234	281	145	170	13.5	84	72
80	45 56	62.5	36	18	32	4	4	22	250	260	316	165	195	17.5	93	81
100	56 70	75.5	37	20	32	5	5	25	300	310	378	200	240	22	117	96
125	70 90	92.5	37	23	32	5	5	28	325	335	416	235	275	22	143	112
160	90 110	115.5	41	25	36	8	5	30	370	380	477	280	320	22	171	130
200	110 140	138.5	45	30	40	15	5	35	450	466	604	340	385	26	230	151

AL = Piston Ø MM = Piston rod Ø

X* = Stroke length

¹⁾ = Thread for piston rod end "G" and "K"

²⁾ = Thread for piston rod end "H" and "F"

³⁾ = ØD4 countersink max. 0.5 mm deep

⁴⁾ = Bleeding: When viewed to the piston rod, the position is by 90° offset in relation to the pipe connection (clockwise)

⁵⁾ = Throttle valve only with end position cushioning "E" (180° for bleeding)

⁸⁾ = Pipe connection "B"

⁹⁾ = Pipe connection "R"

Mounting type MF4

CDM1 MF4

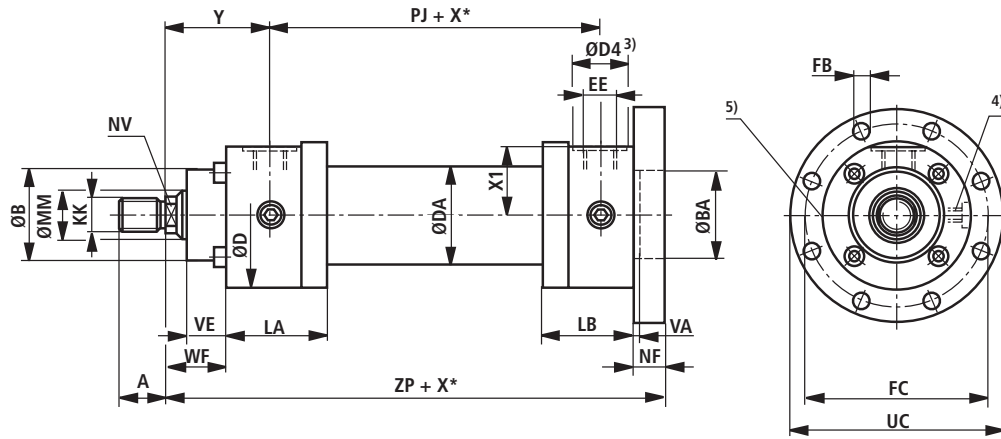

CDM1 MF4..2X/...A: as chevron seal variant and AL $\text{Ø} 50 - 200 \text{ mm}$

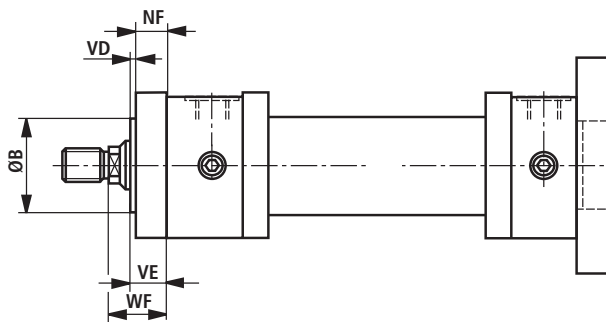

Dimensions MF4 (dimensions in mm)

AL	MM	KK ¹⁾	A ¹⁾	KK ²⁾	A ²⁾	NV	ØD	ØDA	ØD4	EE	ØD4	EE	Y	PJ
Ø	Ø	ISO 6020/1		VW 39 D 920					^{3); 8)}	⁸⁾	^{3); 9)}	⁹⁾		
25	14 18	M12x1.25 M14x1.5	16 18	– M12x1.25	– 16	12 14	56	35	25	G1/4	21	M14x1.5	58	77
32	18 22	M14x1.5 M16x1.5	18 22	– M14x1.5	– 18	14 18	67	42	28	G3/8	26	M18x1.5	64	89
40	22 28	M16x1.5 M20x1.5	22 28	– M16x1.5	– 22	18 22	78	50	34	G1/2	29	M22x1.5	71	97
50	28 36	M20x1.5 M27x2	28 36	– M20x1.5	– 28	22 30	95	60	34	G1/2	29	M22x1.5	72	111
63	36 45	M27x2 M33x2	36 45	– M27x2	– 36	30 36	116	78	42	G3/4	34	M27x2	82	117
80	45 56	M33x2 M42x2	45 56	– M33x2	– 45	36 46	130	95	42	G3/4	34	M27x2	91	134
100	56 70	M42x2 M48x2	56 63	– M42x2	– 56	46 60	158	120	47	G1	43	M33x2	108	162
125	70 90	M48x2 M64x3	63 85	– M48x2	– 63	60 75	192	150	47	G1	43	M33x2	121	174
160	90 110	M64x3 M80x3	85 95	– M64x3	– 85	75 95	237	190	58	G1 1/4	52	M42x2	143	191
200	110 140	M80x3 M100x3	95 112	– M80x3	– 95	95 120	285	230	58	G1 1/4	52	M42x2	190	224

AL	MM	X1	WF	NF	VA	VE	VD	ØB/BA	ZP	ØFC	ØUC	ØFB	LA	LB
Ø	Ø							f8/H8		js13	–1	H13		
25	14 18	26	28	12	3	15	–	32	162	75	90	6.6	58	43
32	18 22	30.5	32	16	3	19	–	40	186	92	110	9	62	47
40	22 28	35.5	32	16	3	19	–	50	206	106	125	9	73	56
50	28 36	44.5	38	20	4	24	4	60	225	126	150	11	74	62
63	36 45	54.5	45	25	4	29	4	70	249	145	170	13.5	84	72
80	45 56	62.5	54	32	4	36	4	85	282	165	195	17.5	93	81
100	56 70	75.5	57	32	5	37	5	106	332	200	240	22	117	96
125	70 90	92.5	60	32	5	37	5	132	357	235	275	22	143	112
160	90 110	115.5	66	36	8	41	5	160	406	280	320	22	171	130
200	110 140	138.5	75	40	15	45	5	200	490	340	385	26	230	151

AL = Piston Ø

MM = Piston rod Ø

X* = Stroke length

¹⁾ = Thread for piston rod end "G" and "K"

²⁾ = Thread for piston rod end "H" and "F"

³⁾ = ØD4 countersink max. 0.5 mm deep

⁴⁾ = Bleeding: When viewed to the piston rod, the position is by 90° offset in relation to the pipe connection (clockwise)

⁵⁾ = Throttle valve only with end position cushioning "E" (180° for bleeding)

⁸⁾ = Pipe connection "B"

⁹⁾ = Pipe connection "R"

Mounting type MT4

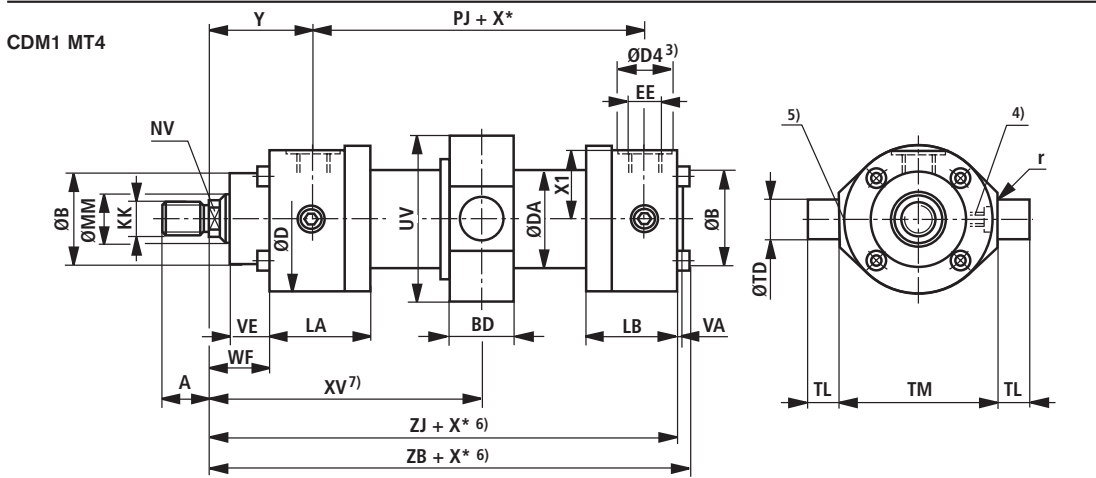

CDM1 MT4..2X/...A: as chevron variant and AL-Ø 50 - 200 mm

Dimensions for cylinder with piston rod extension "LY" in the retracted condition

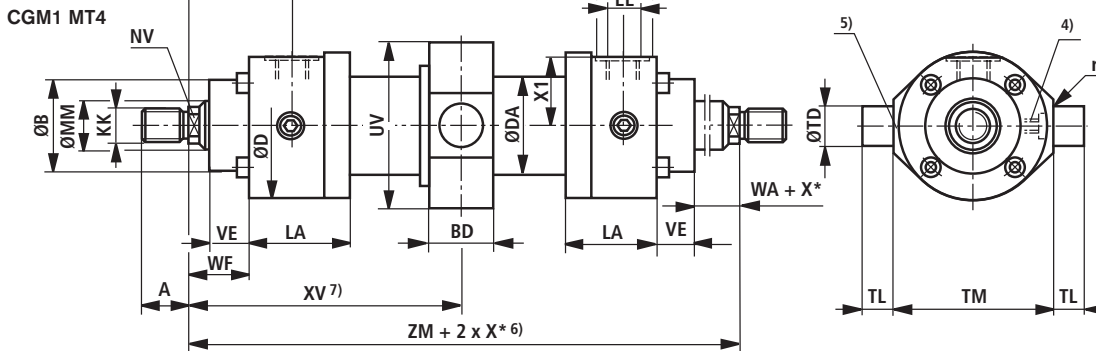
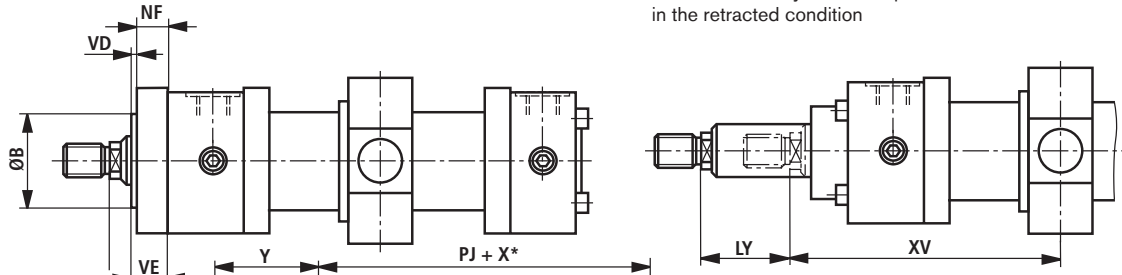

CGM1 MT4..2X/...A: as chevron seal variant and AL-Ø 50 - 200 mm

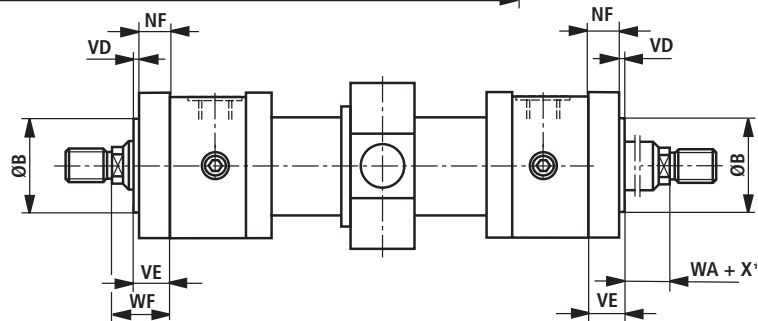

Dimensions MT4 (dimensions in mm)

AL	MM	KK ¹⁾	A ¹⁾	KK ²⁾	A ²⁾	NV	ØB	ØD	ØDA	ØD4	EE	ØD4	EE	Y	PJ	X1	VE
Ø	Ø	ISO 6020/1		VW 39 D 920			f8			3); 8)	8)	3); 9)	9)				
25	14 18	M12x1.25 M14x1.5	16 18	- M14x1.5	- 18	12 14	32	56	35	25	G1/4	21	M14x1.5	58	77	26	15
32	18 22	M14x1.5 M16x1.5	18 22	- M14x1.5	- 18	14 18	40	67	42	28	G3/8	26	M18x1.5	64	89	30.5	19
40	22 28	M16x1.5 M20x1.5	22 28	- M16x1.5	- 22	18 22	50	78	50	34	G1/2	29	M22x1.5	71	97	35.5	19
50	28 36	M20x1.5 M27x2	28 36	- M20x1.5	- 28	22 30	60	95	60	34	G1/2	29	M22x1.5	72	111	44.5	24
63	36 45	M27x2 M33x2	36 45	- M27x2	- 36	30 36	70	116	78	42	G3/4	34	M27x2	82	117	54.5	29
80	45 56	M33x2 M42x2	45 56	- M33x2	- 45	36 46	85	130	95	42	G3/4	34	M27x2	91	134	62.5	36
100	56 70	M42x2 M48x2	56 63	- M42x2	- 56	46 60	106	158	120	47	G1	43	M33x2	108	162	75.5	37
125	70 90	M48x2 M64x3	63 85	- M48x2	- 63	60 75	132	192	150	47	G1	43	M33x2	121	174	92.5	37
160	90 110	M64x3 M80x3	85 95	- M64x3	- 85	75 95	160	237	190	58	G1 1/4	52	M42x2	143	191	115.5	41
200	110 140	M80x3 M100x3	95 112	- M80x3	- 95	95 120	200	285	230	58	G1 1/4	52	M42x2	190	224	138.5	45

AL	MM	WF	WA	NF	VA	VD	ZJ	ZB	ZM	BD	UV	r	ØTD	TL	TM	XV ⁷⁾	XV ⁷⁾	X ^{*6)}	LA	LB
Ø	Ø										¹⁰⁾	f8	js13	h12	min.	max.	min.			
25	14 18	28	13	-	3	-	150	156	193	19	58	0.8	12	10	63	107.5	93.5+X*	22	58	43
32	18 22	32	13	-	3	-	170	176	217	24	67	0.8	16	12	75	118	107+X*	19	62	47
40	22 28	32	13	-	3	-	190	196	239	28	78	1	20	16	90	131	116+X*	23	73	56
50	28 36	38	14	20	4	4	205	213	255	33	95	1	25	20	105	141.5	122.5+X*	28	74	62
63	36 45	45	16	25	4	4	224	234	281	38	116	1.5	32	25	120	164	129+X*	47	84	72
80	45 56	54	18	32	4	4	250	260	316	53	130	2	40	32	135	189.5	138.5+X*	63	93	81
100	56 70	57	20	32	5	5	300	310	378	68	158	2	50	40	160	224	166+X*	70	117	96
125	70 90	60	23	32	5	5	325	335	416	78	210	2.5	63	50	195	261	170+X*	106	143	112
160	90 110	66	25	36	8	5	370	380	477	118	250	3	80	63	240	320	177+X*	163	171	130
200	110 140	75	30	40	15	5	450	466	604	148	300	3	100	80	295	403	221+X*	202	230	151

AL = Piston Ø MM = Piston rod Ø
X* = Stroke length

- 1) = Thread for piston rod end "G" and "K"
- 2) = Thread for piston rod end "H" and "F"
- 3) = ØD4 countersink max. 0.5 mm deep
- 4) = Bleeding: When viewed to the piston rod, the position is by 90° offset in relation to the pipe connection (clockwise)
- 5) = Throttle valve only with end position cushioning "E" (180° for bleeding)
- 6) = Observe min. stroke length "X*min."

7) = Always specify dimension "XV" in clear text on the order (observe XV_{min} and XV_{max})

8) = Pipe connection "B"

9) = Pipe connection "R"

10) = Tolerances according to EN ISO 9013: Thermal Cutting

Remark

Spare cylinder for series 1X

When changing over to series 2X, also change the bearing blocks (trunnion)!

Observe XV_{min}, XV_{max} and X*min.

Mounting type MS2

CDM1 MS2

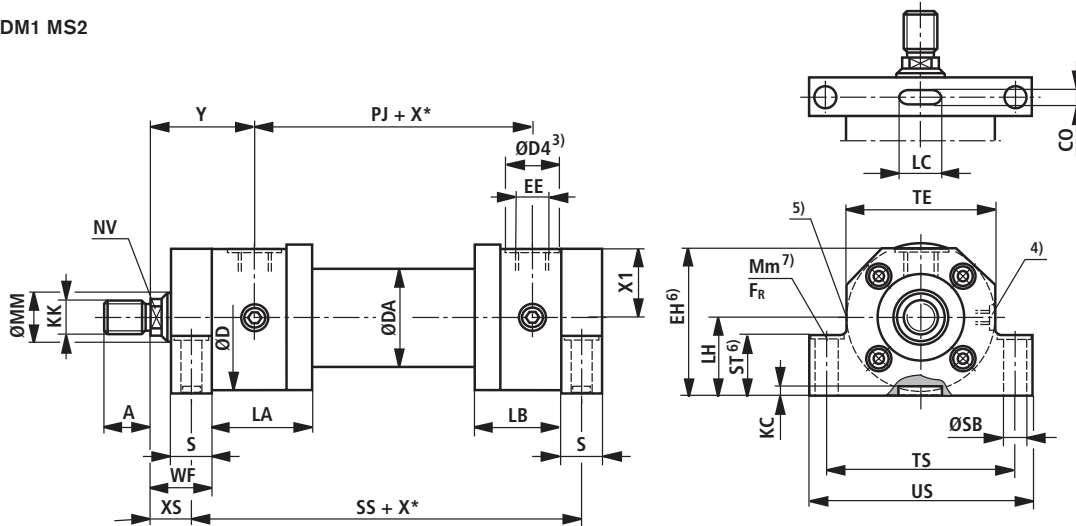

CGM1 MS2

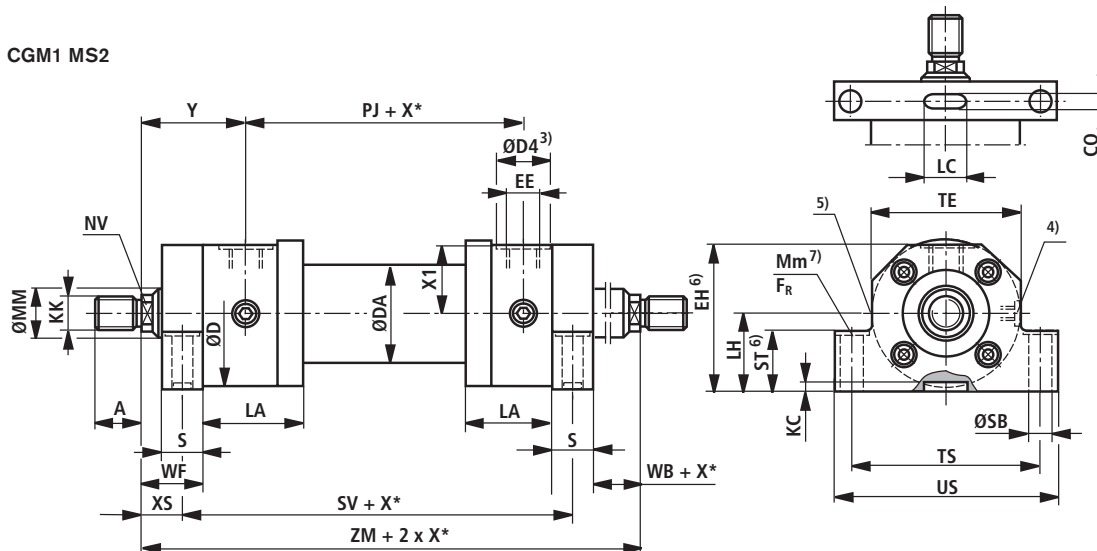

AL = Piston Δ MM = Piston rod Δ

X^* = Stroke length

1) = Thread for piston rod end "G" and "K"

2) = Thread for piston rod end "H" and "F"

3) = $\Delta \Delta D4$ countersink max. 0.5 mm deep

4) = Bleeding: When viewed to the piston rod, the position is by 90° offset in relation to the pipe connection (clockwise)

5) = Throttle valve only with end position cushioning "E" (180° for bleeding)

6) = The specified dimensions are smaller than the max. dimensions in ISO 6020/1

7) = Countersink max. 2 mm deep, for hexagon socket head cap screws to ISO 4762

8) = Pipe connection "B"

9) = Pipe connection "R"

The fixing screws must not be subjected to shear stress. Fixing screws to ISO 4762 (strength class 10.9) must be tightened to the specified tightening torque M_m .

If the calculated friction force F_R is lower than the maximum cylinder force, a thrust key must be installed at the head.

Calculation basis:

– The specified friction force F_R refers to a friction coefficient of 0.2 (steel / steel)

– Foot on head side as fixed bearing

– Foot on cap side as movable bearing

Dimensions MS2 (dimensions in mm)

AL Ø	MM Ø	KK ¹⁾ ISO 6020/1	A ¹⁾	KK ²⁾ VW 39 D 920	A ²⁾	NV	ØD	ØDA	ØD4 3); 8)	EE 8)	ØD4 3); 9)	EE 9)	Y	PJ	X1	WF	WB
25	14 18	M12x1.25 M14x1.5	16 18	- M12x1.25	- 16	12 14	56	35	25	G1/4	21	M14x1.5	58	77	26	28	8
32	18 22	M14x1.5 M16x1.5	18 22	- M14x1.5	- 18	14 18	67	42	28	G3/8	26	M18x1.5	64	89	30.5	32	7
40	22 28	M16x1.5 M20x1.5	22 28	- M16x1.5	- 22	18 22	78	50	34	G1/2	29	M22x1.5	71	97	35.5	32	7
50	28 36	M20x1.5 M27x2	28 36	- M20x1.5	- 28	22 30	95	60	34	G1/2	29	M22x1.5	72	111	44.5	38	6
63	36 45	M27x2 M33x2	36 45	- M27x2	- 36	30 36	116	78	42	G3/4	34	M27x2	82	117	54.5	45	13
80	45 56	M33x2 M42x2	45 56	- M33x2	- 45	36 46	130	95	42	G3/4	34	M27x2	91	134	62.5	54	14
100	56 70	M42x2 M48x2	56 63	- M42x2	- 56	46 60	158	120	47	G1	43	M33x2	108	162	75.5	57	7
125	70 90	M48x2 M64x3	63 85	- M48x2	- 63	60 75	192	150	47	G1	43	M33x2	121	174	92.5	60	4
160	90 110	M64x3 M80x3	85 95	- M64x3	- 85	75 95	237	190	58	G1 1/4	52	M42x2	143	191	115.5	66	6
200	110 140	M80x3 M100x3	95 112	- M80x3	- 95	95 120	285	230	58	G1 1/4	52	M42x2	190	224	138.5	75	3

AL Ø	MM Ø	XS	SS	SV	CO N9	LC +0,5	ZM	KC +0,5	EH ⁶⁾ -1	LH h10	S js13	ØSB H13	ST 6)	TE	TS js13	US -1	LA	LB	FR ⁷⁾ kN	Mm ⁷⁾ Nm
25	14 18	18	142	157	6	25	193	3,5	57	32	20	9	24	56	75	92	58	43	4,90	30
32	18 22	19,5	163	178	8	36	217	4	67	38	25	11	32	67	90	110	62	47	7,90	60
40	22 28	19,5	183	200	8	36	239	4	77,5	43	25	11	32	78	100	120	73	56	7,90	60
50	28 36	22	199	211	10	40	255	4,5	95	52	32	14	42	95	120	145	74	62	11,10	100
63	36 45	29	211	223	10	40	281	4,5	113	62	32	18	50	116	150	180	84	72	21,15	250
80	45 56	34	236	248	14	63	316	5	129	70	40	22	60	130	170	210	93	81	33,35	490
100	56 70	32	293	314	16	70	378	6	153	82	50	26	70	158	205	250	117	96	48,30	850
125	70 90	32	321	352	18	80	416	6	190	100	56	33	80	192	245	300	143	112	77,80	1710
160	90 110	36	364	405	22	125	477	8	232	119	60	33	90	238	295	350	171	130	77,80	1710
200	110 140	39	447	526	28	160	604	9	282	145	72	39	110	285	350	415	230	151	113,25	2970

Proximity switches (dimensions in mm)

CDM1

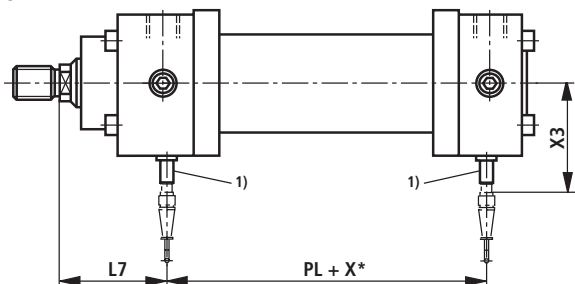

Montagearten

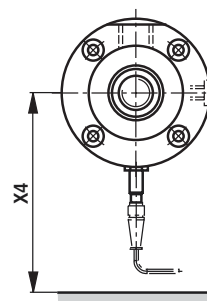

CGM1

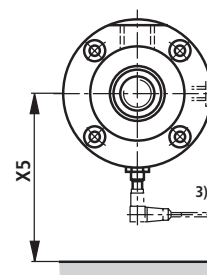
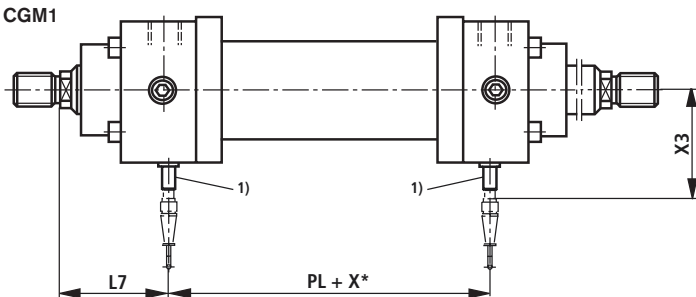

Mating connector with 5 m cable

Material no. **R900026512**

(Mating connector **not** included in the scope of supply, must be ordered separately)



Mating connector, angled, with 5 m cable

(position of cable outlet cannot be defined)

Material no. **R900021404**

(Mating connector **not** included in the scope of supply, must be ordered separately)

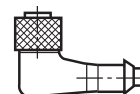

AL Ø	MM Ø	PL	L7	X3	X4	X5
25 ²⁾	14 18	-	-	-	-	-
32 ²⁾	18 22	-	-	-	-	-
40	22 28	97	71	94	170	125
50	28 36	103	76	98	175	130
63	36 45	113	84	103	180	135
80	45 56	124	96	109	185	140
100	56 70	150	114	116	195	150
125	70 90	158	129	126	205	160
160	90 110	181	148	136	215	170
200	110 140	214	195	151	230	185

For main dimensions, see pages 8 to 23 ¹⁾ = The proximity switch is always located opposite to the pipe connection

AL = Piston Ø

MM = Piston rod Ø

X* = Stroke length

²⁾ = Piston Ø 25 to 32 mm

Proximity switch impossible

Proximity switches

Inductive proximity switches are used as reliable end position monitors on hydraulic cylinders. They are an important element for reliably and exactly monitoring safety equipment, locking mechanisms and/or other machine functions in their end position by issuing signals. The proximity switches, which are high pressure-resistant up to 500 bar operate contact-free. For this

reason, they are not subject to wear. For safety reasons, the proximity switches are protected against excessive screwing in. The switching distance can therefore not be changed. On variants with proximity switches (option 1 "E"), the cylinders are provided with proximity switches on both ends.

Technical data (for applications outside these parameters, please consult us!)

Type of operation		PNP normally open
Permissible pressure	bar	500
Operating voltage	V DC	10 to 30
including residual ripple content	%	≤ 15
Voltage drop	V	≤ 1.5
Rated operating voltage	V DC	24
Rated operating current	mA	200
Idle current	mA	≤ 8
Residual current	μA	≤ 10
Repeatability	%	≤ 5
Hysteresis	%	≤ 15
Ambient temperature range	°C	- 25 to + 80
Temperature drift	%	≤ 10
Switching frequency	Hz	1000
Type of protection	Active area	IP 68 to DIN 40050
	Proximity switches	IP 67 to DIN 40050
Housing material		Material no. 1.4104

Pin assignment

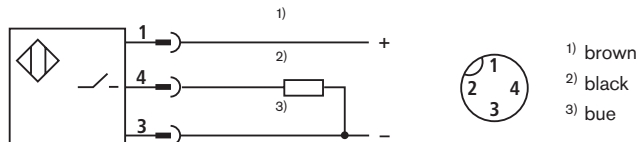

Overview of mounting elements: Series CSM1

CSM1 MP3

See pages 28, 29



CSM1 MT4

See pages 34, 35



CSM1 MP5

See pages 28, 29



CSM1 MS2

See pages 36, 37



CSM1 MF1

See pages 30, 31



CSM1 MF3

See pages 32, 33



General notes on series CSM1

Series CSM1 ...2X is based on series CDM1 ...2X.

(According to ISO 6020/1)

For series CSM1 ...2X the same general notes are valid as for series CDM1 ...2X.

Deviations in dimensions or in the type code, which are due to integrated position measuring systems, are listed on the following pages.

¹⁾ = Not standardised

³⁾ = Piston Ø 40 to 125 mm

⁴⁾ = Always specify dimension "XY" in mm in clear text on the order

⁵⁾ = Piston Ø 63 to 200 mm

⁶⁾ = Not for MF2; MF4

⁷⁾ = Piston Ø 50 to 200 mm

⁹⁾ = Piston Ø 40 to 80 mm, only position 11

¹⁰⁾ = Piston Ø 63 to 200 mm, only position 11

¹¹⁾ = Piston Ø 125 to 200 mm, only position 11

¹⁴⁾ = Subplates only possible with pipe thread ISO 1179-1

¹⁵⁾ = Piston Ø 80 to 200 mm

¹⁶⁾ = Subplates for SL and SV valves (isolator valves)

Note: Seal variants T and S are not rated for static holding functions

¹⁷⁾ = Per piston Ø, only possible with large piston rod Ø

Mounting type MP3/MP5

CSM1 MP3

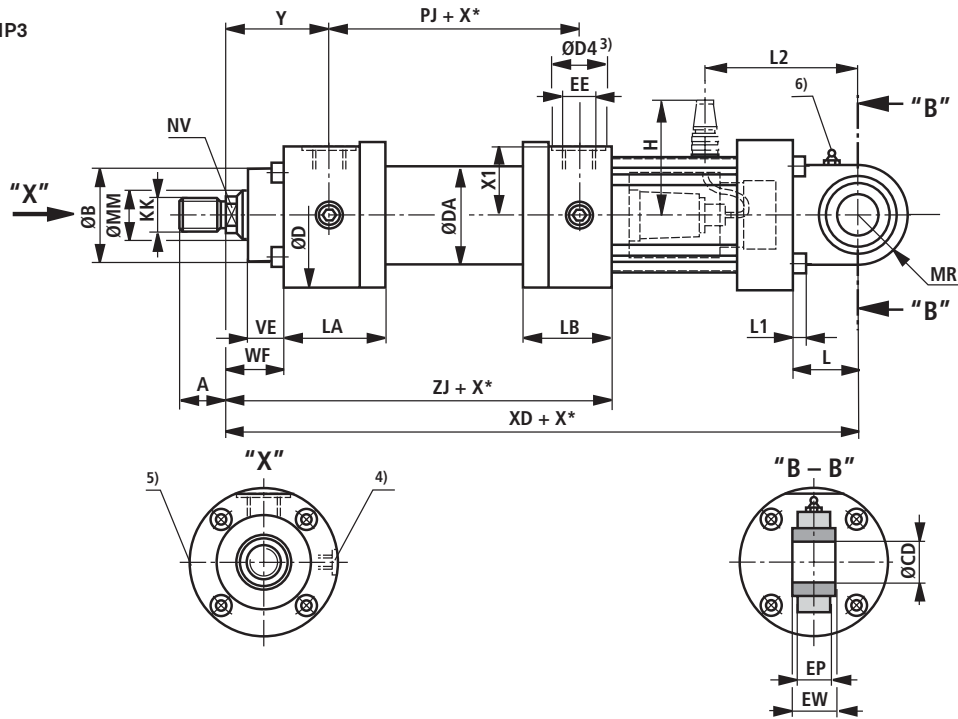

CSM1 MP5

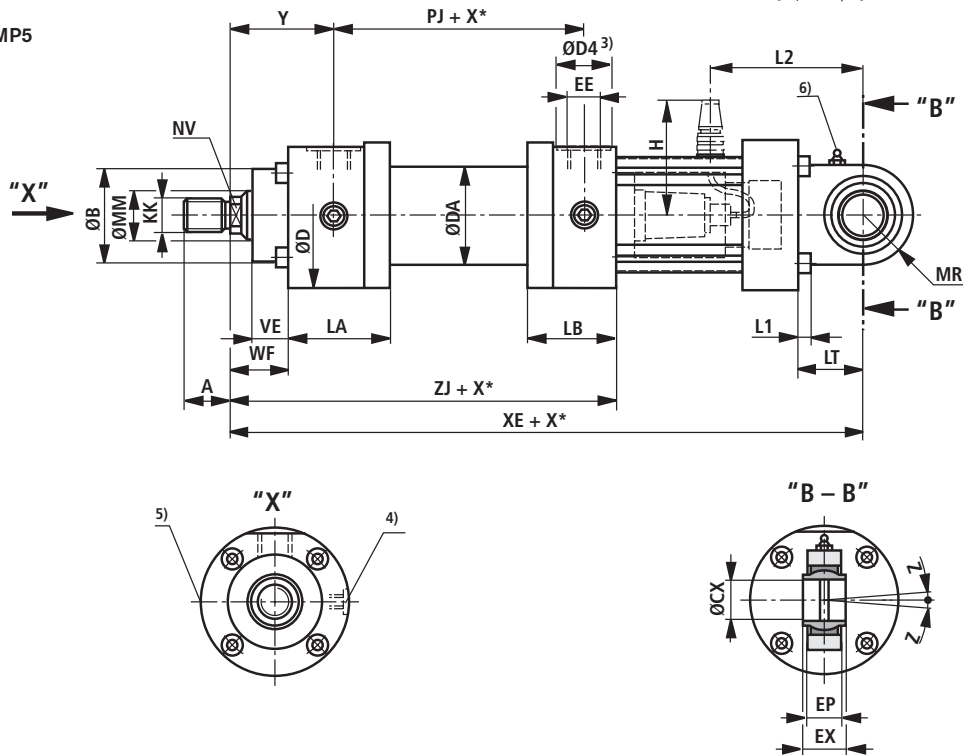

Dimensions MP3/MP5 (dimensions in mm)

AL Ø	MM Ø	KK ¹⁾ ISO 6020/1	A ¹⁾	KK ²⁾ VW 39 D 920	A ²⁾	NV	ØB f8	ØD	ØDA	ØD4 3); 8)	EE 8)	ØD4 3); 9)	EE 9)	Y	PJ
40	28	M20x1.5	28	M16x1.5	22	22	50	78	50	34	G1/2	29	M22x1.5	71	97
50	28 36	M20x1.5 M27x2	28 36	- M20x1.5	- 28	22 30	60	95	60	34	G1/2	29	M22x1.5	72	111
63	36 45	M27x2 M33x2	36 45	- M27x2	- 36	30 36	70	116	78	42	G3/4	34	M27x2	82	117
80	45 56	M33x2 M42x2	45 56	- M33x2	- 45	36 46	85	130	95	42	G3/4	34	M27x2	91	134
100	56 70	M42x2 M48x2	56 63	- M42x2	- 56	46 60	106	158	120	47	G1	43	M33x2	108	162
125	70 90	M48x2 M64x3	63 85	- M48x2	- 63	60 75	132	192	150	47	G1	43	M33x2	121	174
160	90 110	M64x3 M80x3	85 95	- M64x3	- 85	75 95	160	237	190	58	G1 1/4	52	M42x2	143	191
200	110 140	M80x3 M100x3	95 112	- M80x3	- 95	95 120	200	285	230	58	G1 1/4	52	M42x2	190	224

AL Ø	MM Ø	X1	VE	WF	ZJ	XD/XE	CD/CX H9/H7	EP	EW/EX h12	L/LT	L1	MR/MS	H	L2	LA	LB	Z
40	28	35.5	19	32	190	381	20	17	20	38	6	25	110	102	73	56	2°
50	28 36	44.5	24	38	205	407	25	22	25	48	8	32	120	120	74	62	2°
63	36 45	54.5	29	45	224	439	32	27	32	61	10	40	130	138	84	72	4°
80	45 56	62.5	36	54	250	482	40	32	40	78	10	50	120	165	93	81	4°
100	56 70	75.5	37	57	300	545	50	40	50	90	10	63	135	200	117	96	4°
125	70 90	92.5	37	60	325	578	63	52	63	98	12	71	145	208	143	112	4°
160	90 110	115.5	41	66	370	655	80	66	80	127	12	90	165	245	171	130	4°
200	110 140	138.5	45	75	450	765	100	84	100	150	16	112	185	278	230	151	4°

AL = Piston Ø MM = Piston rod Ø

X* = Stroke length

¹⁾ = Thread for piston rod end "G" and "K"

²⁾ = Thread for piston rod end "H" and "F"

³⁾ = ØD4 countersink max. 0.5 mm deep

⁴⁾ = Bleeding: When viewed to the piston rod, the position is by 90° offset in relation to the pipe connection (clock wise)

⁵⁾ = Throttle valve only with end position cushioning "E" (180° for bleeding)

⁶⁾ = Grease nipple cone head form A to DIN 71412

⁸⁾ = Pipe connection "B"

⁹⁾ = Pipe connection "R"

Mounting type MF1

CSM1 MF1

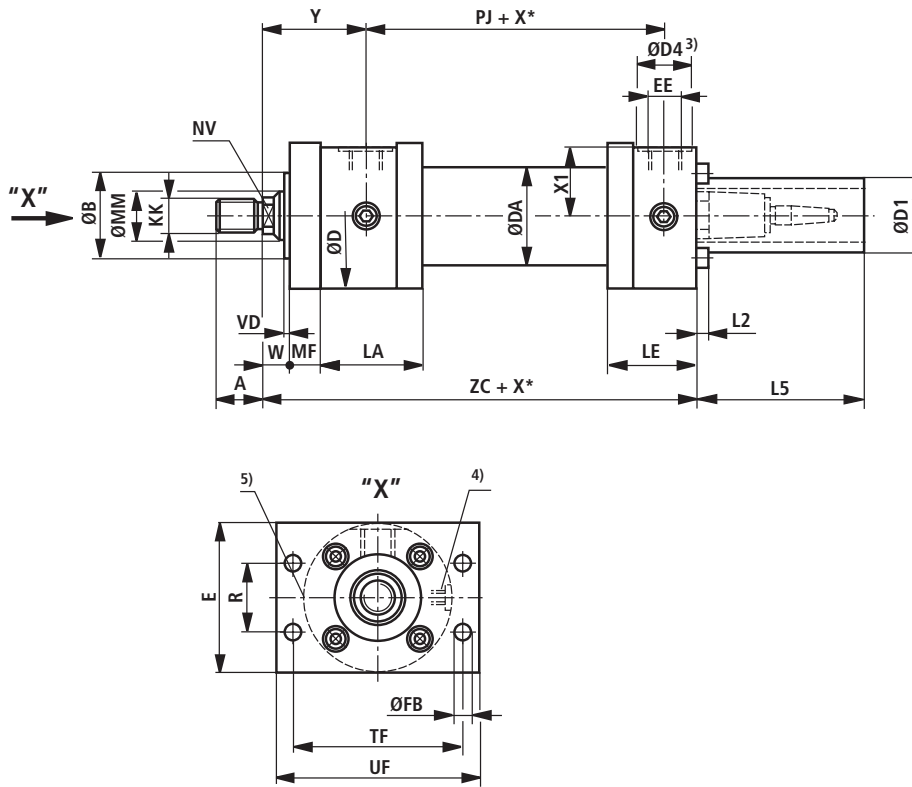

Dimensions MF1 (dimensions in mm)

AL	MM	KK ¹⁾	A ¹⁾	KK ²⁾	A ²⁾	NV	ØB	ØD	ØDA	ØD4	EE	ØD4	EE	Y	PJ
Ø	Ø	ISO 6020/1		VW 39 D 920			f8			3); 8)	8)	3); 9)	9)		
40	28	M20x1.5	28	M16x1.5	22	22	50	78	50	34	G1/2	29	M22x1.5	71	97
50	28 36	M20x1.5 M27x2	28 36	– M20x1.5	– 28	22 30	60	95	60	34	G1/2	29	M22x1.5	72	111
63	36 45	M27x2 M33x2	36 45	– M27x2	– 36	30 36	70	116	78	42	G3/4	34	M27x2	82	117
80	45 56	M33x2 M42x2	45 56	– M33x2	– 45	36 46	85	130	95	42	G3/4	34	M27x2	91	134
100	56 70	M42x2 M48x2	56 63	– M42x2	– 56	46 60	106	158	120	47	G1	43	M33x2	108	162
125	70 90	M48x2 M64x3	63 85	– M48x2	– 63	60 75	132	192	150	47	G1	43	M33x2	121	174

AL	MM	X1	MF	VD	W	ZC	E	R	TF	UF	ØFB	ØD1	L5	LA	LE	L2
Ø	Ø							js13	js13		H13					
40	28	35.5	16	3	16	211	80	40.6	98	115	9	80	166	73	77	0
50	28 36	44.5	20	4	18	224	100	48.2	116.4	140	11	96	166	74	81	0
63	36 45	54.5	25	4	20	237	120	55.5	134	160	13.5	96	166	84	85	0
80	45 56	62.5	32	4	22	281	135	63.1	152.5	185	17.5	96	166	93	112	10
100	56 70	75.5	32	5	25	322	160	76.5	184.8	225	22	96	166	117	118	0
125	70 90	92.5	32	5	28	347	195	90.2	217.1	255	22	96	166	143	134	0

AL = Piston Ø MM = Piston rod Ø

X* = Stroke length

1) = Thread for piston rod end "G" and "K"

2) = Thread for piston rod end "H" and "F"

3) = ØD4 countersink max. 0.5 mm deep

4) = Bleeding: When viewed to the piston rod, the position is by 90° offset in relation to the pipe connection (clockwise)

5) = Throttle valve only with end position cushioning "E" (180° for bleeding)

8) = Pipe connection "B"

9) = Pipe connection "R"

Mounting type MF3

CSM1 MF3

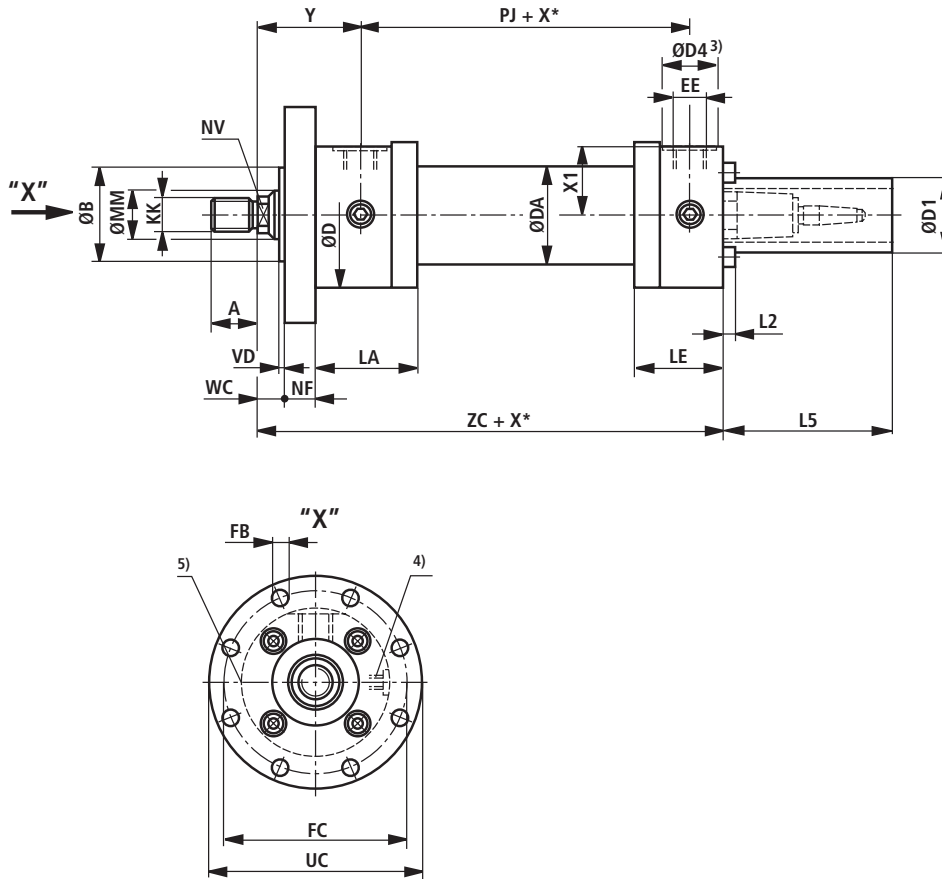

Dimensions MF3 (dimensions in mm)

AL	MM	KK ¹⁾	A ¹⁾	KK ²⁾	A ²⁾	NV	ØB	ØD	ØDA	ØD4	EE	ØD4	EE	Y	PJ
Ø	Ø	ISO 6020/1		VW 39 D 920			f8			3); 8)	8)	3); 9)	9)		
40	28	M20x1.5	28	M16x1.5	22	22	50	78	50	34	G1/2	29	M22x1.5	71	97
50	28 36	M20x1.5 M27x2	28 36	– M20x1.5	– 28	22 30	60	95	60	34	G1/2	29	M22x1.5	72	111
63	36 45	M27x2 M33x2	36 45	– M27x2	– 36	30 36	70	116	78	42	G3/4	34	M27x2	82	117
80	45 56	M33x2 M42x2	45 56	– M33x2	– 45	36 46	85	130	95	42	G3/4	34	M27x2	91	134
100	56 70	M42x2 M48x2	56 63	– M42x2	– 56	46 60	106	158	120	47	G1	43	M33x2	108	162
125	70 90	M48x2 M64x3	63 85	– M48x2	– 63	60 75	132	192	150	47	G1	43	M33x2	121	174
160	90 110	M64x3 M80x3	85 95	– M64x3	– 85	75 95	160	237	190	58	G1 1/4	52	M42x2	143	191
200	110 140	M80x3 M100x3	95 112	– M80x3	– 95	95 120	200	285	230	58	G1 1/4	52	M42x2	190	224

AL	MM	X1	NF	VD	WC	ZC	ØFC	ØUC	ØFB	ØD1	L5	LA	LE	L2
Ø	Ø						js13	–1	H13					
40	28	35.5	16	3	16	211	106	125	9	80	166	73	77	0
50	28 36	44.5	20	4	18	224	126	150	11	96	166	74	81	0
63	36 45	54.5	25	4	20	237	145	170	13.5	96	166	84	85	0
80	45 56	62.5	32	4	22	281	165	195	17.5	96	166	93	112	10
100	56 70	75.5	32	5	25	322	200	240	22	96	166	117	118	0
125	70 90	92.5	32	5	28	347	235	275	22	96	166	143	134	0
160	90 110	115.5	36	5	30	390	280	320	22	96	166	171	150	0
200	110 140	138.5	40	5	35	472	340	385	26	96	166	230	173	0

AL = Piston Ø MM = Piston rod Ø

X* = Stroke length

¹⁾ = Thread for piston rod end "G" and "K"

²⁾ = Thread for piston rod end "H" and "F"

³⁾ = ØD4 countersink max. 0.5 mm deep

⁴⁾ = Bleeding: When viewed to the piston rod, the position is by 90° offset in relation to the pipe connection (clockwise)

⁵⁾ = Throttle valve only with end position cushioning "E" (180° for bleeding)

⁸⁾ = Pipe connection "B"

⁹⁾ = Pipe connection "R"

Mounting type MT4

CSM1 MT4

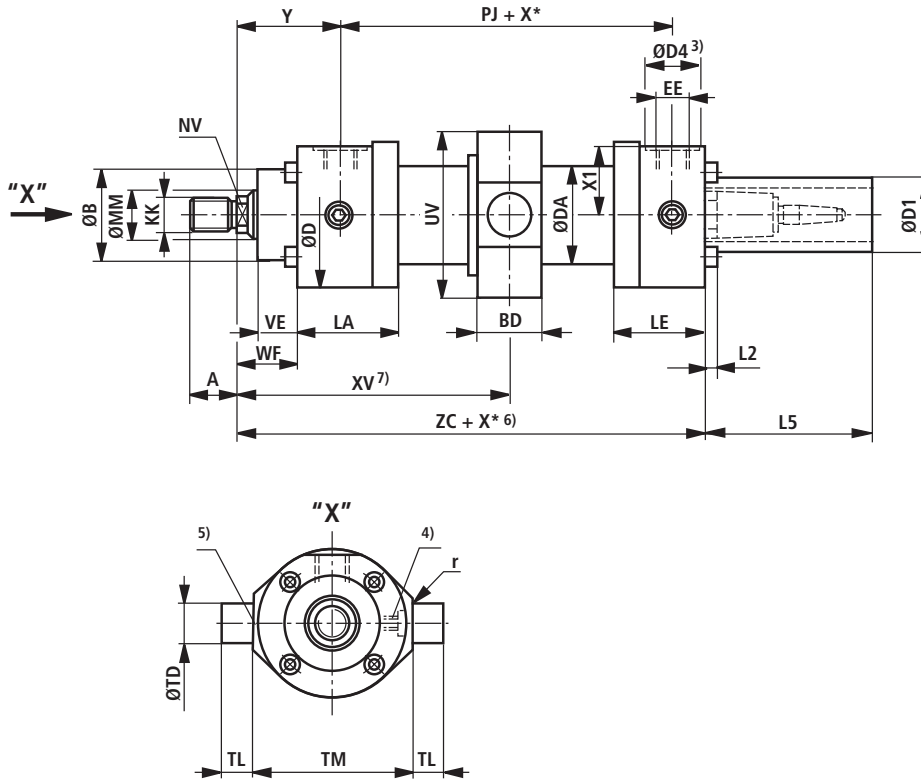

Dimensions MT4 (dimensions in mm)

AL Ø	MM Ø	KK ¹⁾ ISO 6020/1	A ¹⁾	KK ²⁾ VW 39 D 920	A ²⁾	NV	ØB f8	ØD	ØDA	ØD4 3); 8)	EE 8)	ØD4 3); 9)	EE 9)	Y	PJ	X1
40	28	M20x1.5	28	M16x1.5	22	22	50	78	50	34	G1/2	29	M22x1.5	71	97	35.5
50	28 36	M20x1.5 M27x2	28 36	- M20x1.5	- 28	22 28	60	95	60	34	G1/2	29	M22x1.5	72	111	44.5
63	36 45	M27x2 M33x2	36 45	- M27x2	- 36	28 36	70	116	78	42	G3/4	34	M27x2	82	117	54.5
80	45 56	M33x2 M42x2	45 56	- M33x2	- 45	36 46	85	130	95	42	G3/4	34	M27x2	91	134	62.5
100	56 70	M42x2 M48x2	56 63	- M42x2	- 56	46 60	106	158	120	47	G1	43	M33x2	108	162	75.5
125	70 90	M48x2 M64x3	63 85	- M48x2	- 63	60 75	132	192	150	47	G1	43	M33x2	121	174	92.5
160	90 110	M64x3 M80x3	85 95	- M64x3	- 85	75 90	160	238	190	58	G1 1/4	52	M42x2	143	191	115.5
200	110 140	M80x3 M100x3	95 112	- M80x3	- 95	90 120	200	285	230	58	G1 1/4	52	M42x2	190	224	138.5

AL Ø	MM Ø	VE	WF	ZC	BD	UV 10)	r	ØTD f8	TL js13	TM h12	XV ⁷⁾ min.	XV ⁷⁾ max.	X ⁺⁶⁾ min.	ØD1	L5	LA	LE	L2
40	28	19	32	211	28	78	1	20	16	90	131	116+X*	23	80	166	73	77	0
50	28 36	24	38	224	33	95	1	25	20	105	141.5	122.5+X*	28	96	166	74	81	0
63	36 45	29	45	237	38	116	1.5	32	25	120	164	129+X*	47	96	166	84	85	0
80	45 56	36	54	281	53	130	2	40	32	135	189.5	138.5+X*	63	96	166	93	112	10
100	56 70	37	57	322	68	158	2	50	40	160	224	166+X*	70	96	166	117	118	0
125	70 90	37	60	347	78	210	2.5	63	50	195	261	170+X*	106	96	166	143	134	0
160	90 110	41	66	390	118	250	3	80	63	240	320	177+X*	163	96	166	171	150	0
200	110 140	45	75	472	148	300	3	100	80	295	403	221+X*	202	96	166	230	173	0

AL = Piston Ø MM = Piston rod Ø

X* = Stroke length

1) = Thread for piston rod end "G" and "K"

2) = Thread for piston rod end "H" and "F"

3) = ØD4 countersink max. 0.5 mm deep

4) = Bleeding: When viewed to the piston rod, the position is by 90° offset in relation to the pipe connection (clockwise)

5) = Throttle valve only with end position cushioning "E" (180° for bleeding)

6) = Observe min. stroke length "X*min."

7) = Always specify dimension "XV" in clear text on the order (take account of XV_{min} and XV_{max})

8) = Pipe connection "B"

9) = Pipe connection "R"

10) = Tolerances according to EN ISO 9013: Thermal Cutting

Mounting type MS2

CSM1 MS2

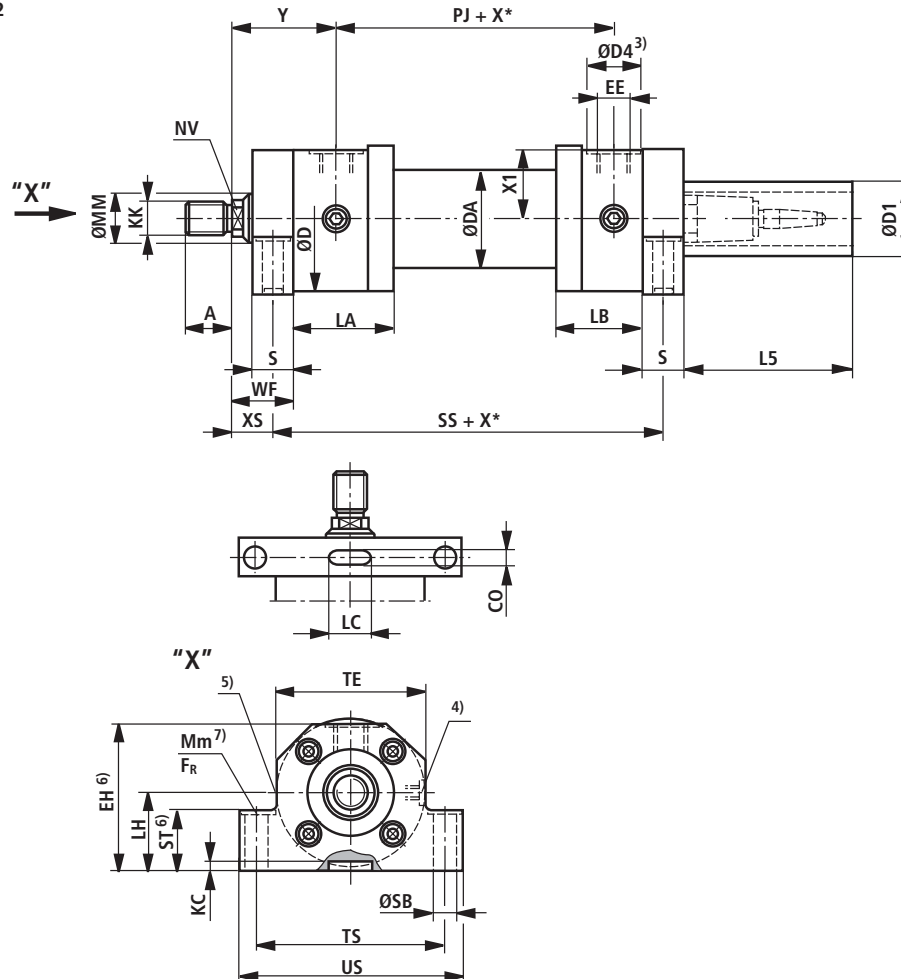

AL = Piston Ø MM = Piston rod Ø

X* = Stroke length

1) = Thread for piston rod end "G" and "K"

2) = Thread for piston rod end "H" and "F"

3) = ØD4 countersink max. 0.5 mm deep

4) = Bleeding: When viewed to the piston rod, the position is by 90° offset in relation to the pipe connection (clockwise)

5) = Throttle valve only with end position cushioning "E" (180° for bleeding)

6) = The specified dimensions are smaller than the max. dimensions in ISO 6020/1

7) = Countersink max. 2 mm deep, for hexagon socket head cap screws to ISO 4762

The fixing screws must not be subjected to shear stress. Fixing screws to ISO 4762 (strength class 10.9) must be tightened to the specified tightening torque M_m .

If the calculated friction force F_R is lower than the maximum cylinder force, a thrust key must be installed at the head.

Calculation basis:

- The specified friction force F_R refers to a friction coefficient of 0.2 (steel / steel)

- Foot on head side as fixed bearing

- Foot on cap side as movable bearing

8) = Pipe connection "B"

9) = Pipe connection "R"

Dimensions MS2 (dimensions in mm)

AL Ø	MM Ø	KK ¹⁾ ISO 6020/1	A ¹⁾	KK ²⁾ VW 39 D 920	A ²⁾	NV	ØD	ØDA	ØD4 3); 8)	EE 8)	ØD4 3); 9)	EE 9)	Y	PJ	X1	WF	XS
40	28	M20x1.5	28	M16x1.5	22	22	78	50	34	G1/2	29	M22x1.5	71	97	35.5	32	19.5
50	28 36	M20x1.5 M27x2	28 36	- M20x1.5	- 28	22 30	95	60	34	G1/2	29	M22x1.5	72	111	44.5	38	22
63	36 45	M27x2 M33x2	36 45	- M27x2	- 36	30 36	116	78	42	G3/4	34	M27x2	82	117	54.5	45	29
80	45 56	M33x2 M42x2	45 56	- M33x2	- 45	36 46	130	95	42	G3/4	34	M27x2	91	134	62.5	54	34
100	56 70	M42x2 M48x2	56 63	- M42x2	- 56	46 60	158	120	47	G1	43	M33x2	108	162	75.5	57	32
125	70 90	M48x2 M64x3	63 85	- M48x2	- 63	60 75	192	150	47	G1	43	M33x2	121	174	92.5	60	32
160	90 110	M64x3 M80x3	85 95	- M64x3	- 85	75 95	237	190	58	G1 1/4	52	M42x2	143	191	115.5	66	36
200	110 140	M80x3 M100x3	95 112	- M80x3	- 95	95 120	285	230	58	G1 1/4	52	M42x2	190	224	138.5	75	39

AL Ø	MM Ø	SS	CO N9	LC +0.5	KC +0.5	EH ⁶⁾ -1	LH h10	S js13	ØSB H13	ST 6)	TE	TS js13	US -1	ØD1	L5	LA	LB	FR ⁷⁾ kN	Mm ⁷⁾ Nm
40	28	183	8	36	4	77.5	43	25	11	32	78	100	120	80	166	73	56	7.90	60
50	28 36	199	10	40	4.5	95	52	32	14	42	95	120	145	96	166	74	62	11.10	100
63	36 45	211	10	40	4.5	113	62	32	18	50	116	150	180	96	166	84	72	21.15	250
80	45 56	236	14	63	5	129	70	40	22	60	130	170	210	96	166	93	81	33.35	490
100	56 70	293	16	70	6	153	82	50	26	70	158	205	250	96	138	117	96	48.30	850
125	70 90	321	18	80	6	190	100	56	33	80	192	245	300	96	132	143	112	77.80	1710
160	90 110	364	22	125	8	232	119	60	33	90	238	295	350	96	126	171	130	77.80	1710
200	110 140	447	28	160	9	282	145	72	39	110	285	350	415	96	116	230	151	113.25	2970

Position measuring system

The measuring system, which is pressure-resistant up to 500 bar operates contact-free and absolute. This position measuring system is based on the magnetostrictive effect. Here, the coincidence of two magnetic fields triggers a torsional pulse.

This pulse runs on a wave guide inside the scale from the measuring point to the sensor head. The running time is constant and almost independent of temperatures. It is proportional to the position of the magnet and hence a measure for the actual position value and is converted within the sensor into a direct analogue or digital output.

Technical data (for applications outside these parameters, please consult us!)

Operating pressure	bar	250
Analogue output	V	0 to 10
	Load resistance	kΩ ≥ 5
	Resolution	Infinite
Analogue output	mA	4 to 20
	Load resistance	Ω 0 to 500
	Resolution	Infinite
Digital output		SSI 24 bits Gray-coded
	Resolution	μm 5
	Direction of measurement	Forward
Linearity (absolute accuracy)	Analogue	% ≤ ±0.02 % (referred to measuring length) mm min. ±0.05
	Digital	% ≤ ±0.01 % (referred to measuring length) mm min. ±0.04
Reproducibility	% mm	±0.001 (referred to measuring length) min. ±0.0025
Hysteresis	mm	≤ 0.004
Supply voltage	V DC	24 (± 10 % with analogue output)
	Current consumption	mA 100
	Residual ripple	% s-s ≤ 1
	Current consumption	V DC mA 70
	Residual ripple	% s-s ≤ 1
Type of protection	Tube and flange	IP 67
	Sensor electronics	IP 65
Operating temperature	Sensor electronics	°C - 40 to + 75
Temperature coefficient	Voltage	ppm/°C 70
	Current	ppm/°C 90

Position measuring system

Mounting types

MP3, MP5

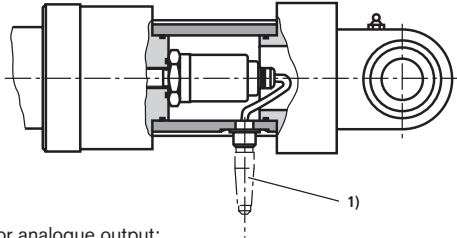

MF3, MF4, MT4, MS2

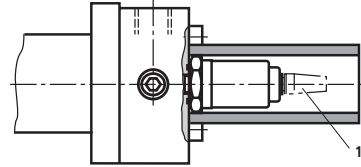

- 1) For analogue output:
6-pin mating connector
Material no. **R900072231**
(The mating connector is **not** included in the scope of supply, but must be ordered separately)
Type of protection: IP 67



- 1) For digital output:
7-pin mating connector, Material no. **R900079551**
(The mating connector is **not** included in the scope of supply, but must be ordered separately)
Type of protection: IP 67



Pin assignment

Position measuring system (analogue output)

Plug-in connector (viewed to pin side)

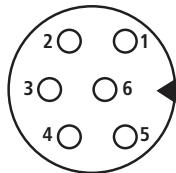

Pin	Cable	Signal / current	Signal / voltage
1	Grey	4 to 20 mA	0 to 10 V
2	Pink	GND	GND
3	Yellow	n. c.	n. c.
4	Green	n. c.	n. c.
5	Brown	+24 V DC (±10%)	+24 V DC (±10%)
6	White	GND	GND

Position measuring system (digital output)

Plug-in connector (viewed to pin side)

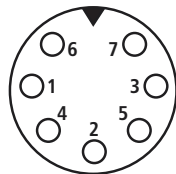

Pin	Cable	Signal / SSi
1	Grey	Data (-)
2	Pink	Data (+)
3	Yellow	Clock pulse (+)
4	Green	Clock pulse (-)
5	Brown	+24 V DC (-15%/+20%)
6	White	0 V (GND)
7	-	n. c.

Piston rod end E (dimensions in mm)

AL Ø	MM Ø	KK ISO 6020/1	A
32	22	M16x1.5	22
40	22 28	M16x1.5 M20x1.5	22 28
50	28 36	M20x1.5 M27x2	28 36
63	36 45	M27x2 M33x2	36 45
80	45 56	M33x2 M42x2	45 56

AL Ø	MM Ø	KK ISO 6020/1	A
100	56 70	M42x2 M48x2	56 63
125	70 90	M48x2 M64x3	63 85
160	90 110	M64x3 M80x3	85 95
200	110 140	M80x3 M100x3	95 112

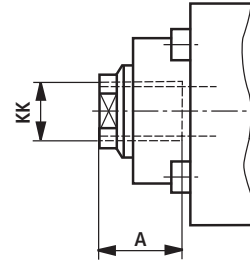

Enlarged pipe connections (dimensions in mm)

CDM1

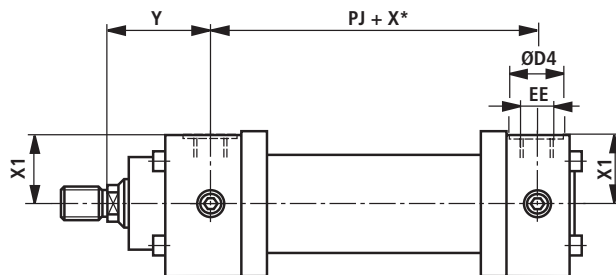

CGM1

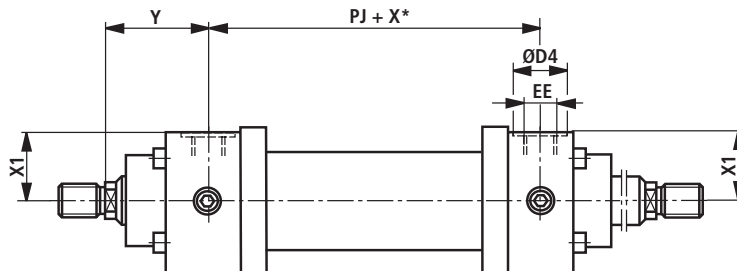

AL Ø	Variant "S" ISO 1179-1				
	EE	ØD4 ¹⁾	Y	PJ	X1
25	-	-	-	-	-
32	-	-	-	-	-
40	-	-	-	-	-
50	-	-	-	-	-
63	G1	47	80	121	53.5
80	G1	47	91	134	60.5
100	G1 1/4	58	108	162	74
125	G1 1/4	58	121	174	92
160	G1 1/2	65	143	191	114.5
200	G1 1/2	65	190	224	138.5

For main dimensions, see pages 8 to 23, and pages 28 to 37

AL = Piston Ø

X* = Stroke length

¹⁾ = ØD4 countersink max. 0.5 mm deep

Flanged connections (dimensions in mm)

CDM1

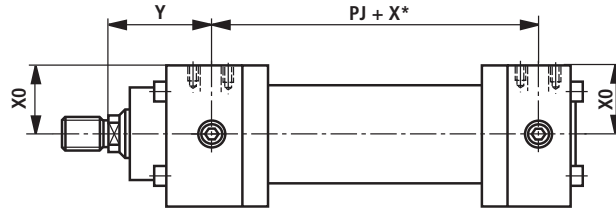

CGM1

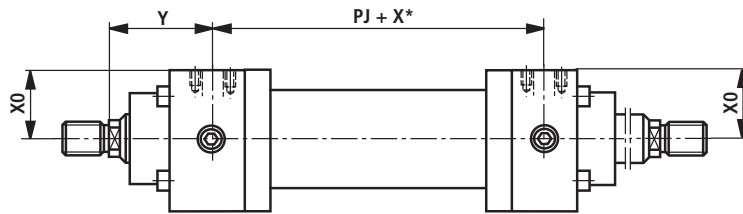

Drilling pattern for rectangular flange to ISO 6162-1
($\hat{=}$ SAE 3000 PSI)

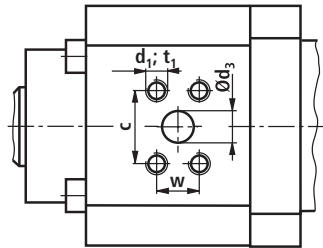

Drilling pattern for square flange to ISO 6164

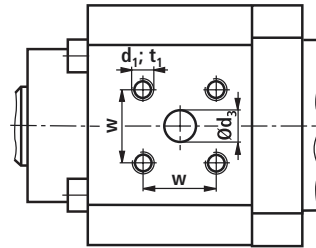

AL	Variant "F" ISO 6162-1 ($\hat{=}$ SAE 3000 PSI) ¹⁾										Variant "H" ISO 6164						
	Ø	Y	PJ	X0	d ₃	d ₃ ¹⁾	c	w	d ₁	t ₁ ²⁾	Y	PJ	X0	d ₃	w	d ₁	t ₁ ²⁾
25	-	-	-	-	-	-	-	-	-	-	-	-	-	-	-	-	-
32	-	-	-	-	-	-	-	-	-	-	-	-	-	-	-	-	-
40	-	-	-	-	-	-	-	-	-	-	69	101	34.5	10	24.7	M6	13
50	72	111	41	13	1/2"	38.1	17.5	M8	14	72	111	44	10	24.7	M6	13	
63	82	117	52	13	1/2"	38.1	17.5	M8	16	82	117	52	13	29.7	M8	16	
80	91	134	60	13	1/2"	38.1	17.5	M8	16	91	134	60	13	29.7	M8	16	
100	108	162	72	19	3/4"	47.6	22.3	M10	20	108	162	72	19	35.4	M8	16	
125	121	174	91	19	3/4"	47.6	22.3	M10	20	121	174	91	19	35.4	M8	16	
160	143	191	114	25	1"	52.4	26.2	M10	20	143	191	114	25	43.8	M10	20	
200	190	224	138	25	1"	52.4	26.2	M10	20	190	224	138	25	43.8	M10	20	

For main dimensions, see pages 8 to 23, and pages 28 to 37

AL = Piston Ø

X* = Stroke length

¹⁾ = Flange drilling pattern to ISO 6162-1 corresponds to flange drilling pattern to SAE 3000 PSI

²⁾ = Depth of thread

Subplates for valve mounting (SL and SV valves)

Remark:

Valves, fittings and piping are **not** included in the scope of supply!

- 1 Port B to piston side according to ISO 6164
- 2 Bore for locating pin
- 3 Adapter plate for mounting type MT4 (included in the scope of supply for MT4)
- 4 Pipe connection "B", for dimensions see also pages 9 to 23 and pages 33 to 37

Installation situation with MT4

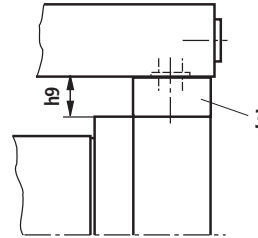

Important note:

Subplates for SL and SV valves (isolator valves)

Note:

Seal variants T and S not rated for static holding function!

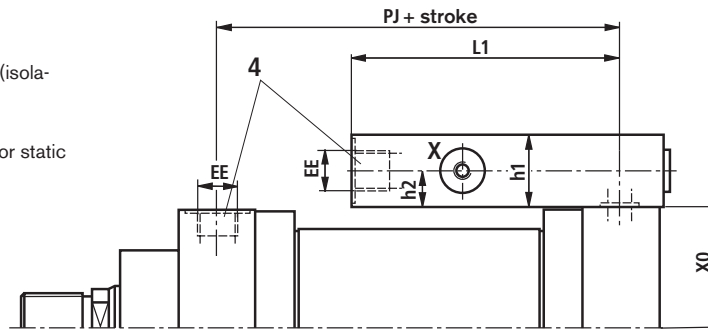

Size 6

Porting pattern to DIN 24340 form A and ISO 4401

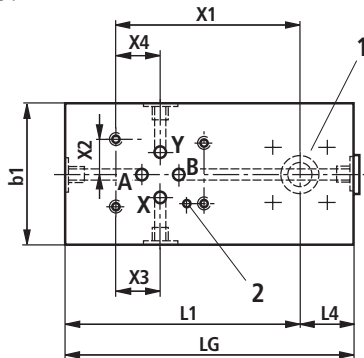

Sizes 10 and 20

Porting pattern to DIN 24340 form D and ISO 5781

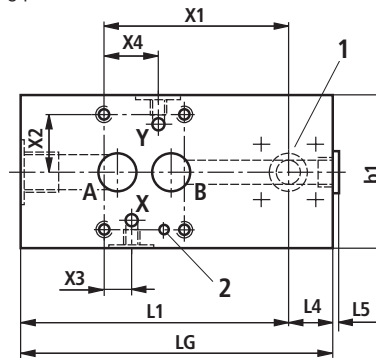

Piping symbol

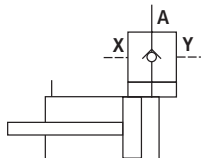

Subplates for valve mounting (SL and SV valves – dimensions in mm)

AL Ø	Valve size	PJ	EE	Minimum stroke ¹⁾		X0	Plate dimensions							Port size, position of ports					Position point of valve		
				2)	3)		L1	L4	L5	LG	b1	h1	h9	h2	A	X	Y	X3	X4	X1	X2
40	6	97	G 1/2	100	100	34.5	90	20	4	110	55	40	10	20	G 1/2	G 1/4	G 1/4	21.5	21.5	65.5	15.5
50	6	111	G 1/2	100	100	44	90	20	4	110	55	40	10	20	G 1/2	G 1/4	G 1/4	21.5	21.5	65.5	15.5
63	6	117	G 3/4	100	100	52	100	25	5	125	55	45	10	22.5	G 3/4	G 1/4	G 1/4	21.5	21.5	70.5	15.5
	10	117	G 3/4	100	100	52	105	25	5	130	85	45	10	22.5	G 3/4	G 1/4	G 1/4	21.5	21.5	73	33.35
80	6	134	G 3/4	100	100	60	100	25	5	125	55	45	10	22.5	G 3/4	G 1/4	G 1/4	21.5	21.5	70.5	15.5
	10	134	G 3/4	100	100	60	105	25	5	130	85	45	10	22.5	G 3/4	G 1/4	G 1/4	21.5	21.5	73	33.35
100	10	162	G 1	100	100	72	102	28	5	130	85	50	10	25	G 1	G 1/4	G 1/4	21.5	21.5	70	33.35
125	10	174	G 1	100	106	91	102	28	5	130	85	50	20	25	G 1	G 1/4	G 1/4	21.5	21.5	70	33.35
	20	174	G 1	100	106	91	137	28	5	165	100	50	20	25	G 1	G 1/4	G 1/4	20.6	39.5	92	39.7
160	10	191	G 1 1/4	100	163	114	115	35	5	150	85	60	20	30	G 1 1/4	G 1/4	G 1/4	21.5	21.5	80	33.35
	20	191	G 1 1/4	100	163	114	140	35	5	175	100	60	20	30	G 1 1/4	G 1/4	G 1/4	20.6	39.5	95	39.7
200	10	224	G 1 1/4	100	202	138	115	35	5	150	85	60	20	30	G 1 1/4	G 1/4	G 1/4	21.5	21.5	80	33.35
	20	224	G 1 1/4	100	202	138	140	35	5	175	100	60	20	30	G 1 1/4	G 1/4	G 1/4	20.6	39.5	95	39.7

AL = Piston Ø

¹⁾ Indication only valid for the following connection situation!

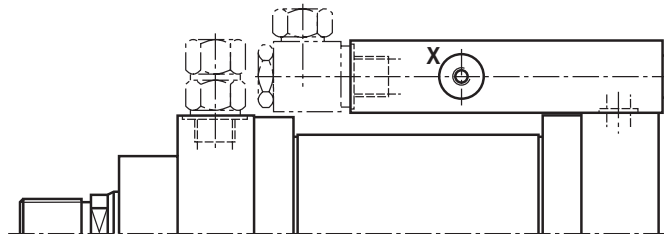

²⁾ Not for MT4

³⁾ Only for MT4

Subplates for valve mounting (directional and high-response valves)

- 1 Port B to piston side according to ISO 6164
- 2 Bore for locating pin
- 3 Adapter plate for mounting type MT4 (included in the scope of supply for MT4)
- 4 Pipe connection "B", for dimensions, see also pages 9 to 23 and pages 33 to 37

Installation situation with MT4

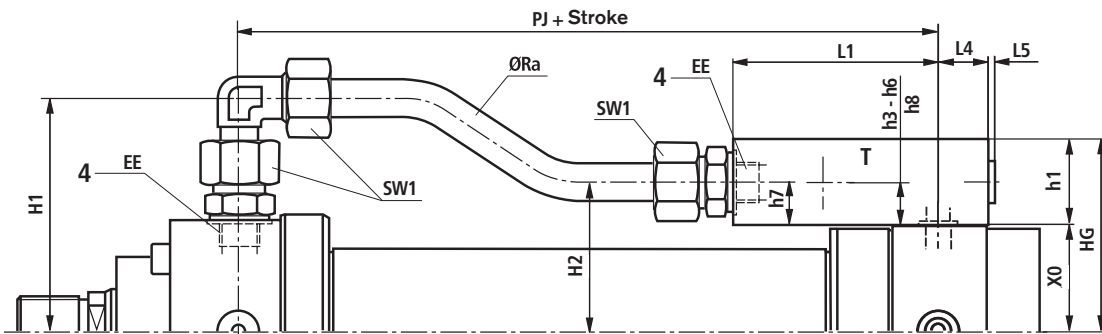
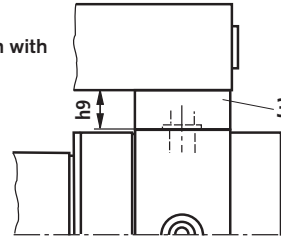

Size 6

Porting pattern to DIN 24340 form A and ISO 4401

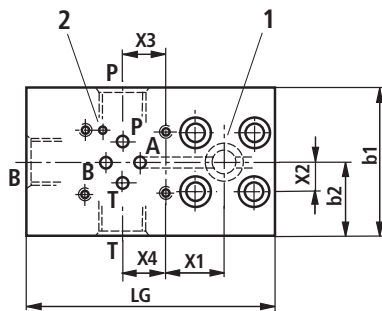

Size 10

Porting pattern to DIN 24340 form A and ISO 4401

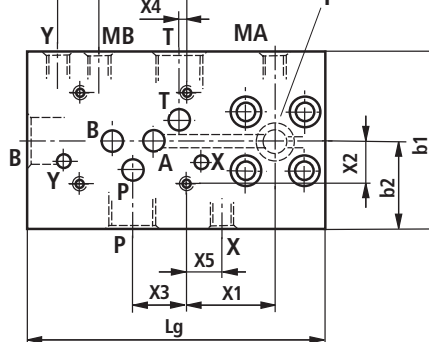

Size 16

Porting pattern to DIN 24340 form A and ISO 4401

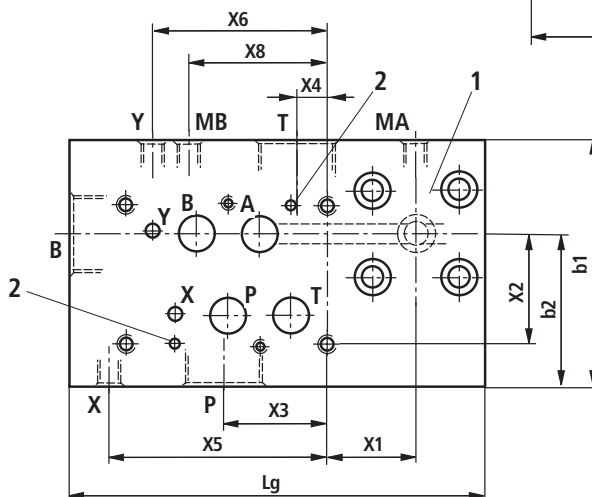

Subplates for valve mounting (directional and high-response valves – dimensions in mm)

AL Ø	Valve size	PJ	EE	Minimum stroke	Plate and piping dimension																
					L1	L4	L5 _{max}	H1	H2 ¹⁾	H2 ²⁾	SW1	ØRa	b1	h1	lg	HG ¹⁾	HG ²⁾	b2	X0	h7	h9
40	6	101	G1/2	225	90	20	4	90	54.5	64.5	30	16.0 x 2.5	65	40	110	74.5	84.5	32.5	34.5	20	10
50	6	111	G1/2	215	90	20	4	99	64	74	30	16.0 x 2.5	65	40	110	84	94	32.5	44	20	10
63	6	117	G3/4	250	100	25	5	119	74.5	84.5	36	20.0 x 3.0	75	45	125	97	107	37.5	52	22.5	10
	10	117	G3/4	275	125	25	5	119	75	85	36	20.0 x 3.0	90	70	150	122	132	45	52	23	10
80	6	134	G3/4	235	100	25	5	127	82.5	92.5	36	20.0 x 3.0	75	45	125	105	115	37.5	60	22.5	10
	10	134	G3/4	260	125	25	5	127	83	93	36	20.0 x 3.0	90	70	150	130	140	45	60	23	10
100	10	162	G1	280	132	28	5	148	102	112	46	25.0 x 4.0	90	80	160	152	162	45	72	30	10
125	10	174	G1	270	132	28	5	165	121	141	46	25.0 x 4.0	90	80	160	171	191	45	91	30	20
	16	174	G1	300	162	28	5	165	131	151	46	25.0 x 4.0	120	90	190	181	209	229	55	114	40
160	10	191	G1 1/4	295	135	35	5	193.5	149	169	50	30.0 x 5.0	105	95	170	209	229	55	114	35	20
	16	191	G1 1/4	335	175	35	5	193.5	159	179	50	30.0 x 5.0	125	100	210	214	234	77.5	114	45	20
200	10	224	G1 1/4	260	135	35	5	216.5	173	193	50	30.0 x 5.0	105	95	170	233	253	55	138	35	20
	16	224	G1 1/4	300	175	35	5	216.5	183	203	50	30.0 x 5.0	125	100	210	238	258	77.5	138	45	20

AL Ø	Valve size	Port size, position of ports															
		P	X3	h3	T	X4	h4	X	X5	h5	Y	X6	h6	MA	MB	X8	h8
40	6	G1/2	21.5	20	G1/2	21.5	20	-	-	-	-	-	-	-	-	-	-
50	6	G1/2	21.5	20	G1/2	21.5	20	-	-	-	-	-	-	-	-	-	-
63	6	G3/4	21.5	22.5	G3/4	21.5	22.5	-	-	-	-	-	-	-	-	-	-
	10	G3/4	27	33	G3/4	3.5	33	G1/4	18	47	G1/4	65	47	G1/4	G1/4	60	17
80	6	G3/4	21.5	22.5	G3/4	21.5	22.5	-	-	-	-	-	-	-	-	-	-
	10	G3/4	27	33	G3/4	3.5	33	G1/4	18	47	G1/4	65	47	G1/4	G1/4	60	17
100	10	G1	27	30	G1	3.5	40	G1/4	18	57	G1/4	65	57	G1/4	G1/4	58	20
125	10	G1	27	30	G1	3.5	40	G1/4	18	57	G1/4	65	57	G1/4	G1/4	58	20
	16	G1	50	26	G1	17.0	25	G1/4	105	45	G1/4	88	70	G1/4	G1/4	88	35
160	10	G1 1/4	27	35	G1 1/4	3.5	45	G1/4	20	72	G1/4	65	72	G1/4	G1/4	55	25
	16	G1 1/4	52	32	G1 1/4	15.0	32	G1/4	110	55	G1/4	88	80	G1/4	G1/4	88	40
200	10	G1 1/4	27	35	G1 1/4	3.5	45	G1/4	20	72	G1/4	65	72	G1/4	G1/4	55	25
	16	G1 1/4	52	32	G1 1/4	15.0	32	G1/4	110	55	G1/4	88	80	G1/4	G1/4	88	40

¹⁾ Not for MT4

²⁾ Only for MT4

Dimensions h3, h4, h5, h6, h8 and X3, X4, X5, X6, determine the position of ports P, T, B, X, Y.

AL Ø	Valve size	Position point of valve	
		X1	X2
40	6	25	15.5
50	6	25	15.5
63	6	30	15.5
	10	45	21.6
80	6	30	15.5
	10	45	21.6
100	10	52	21.6
125	10	52	21.6
	16	37	55.6
160	10	55	21.6
	16	45	55.6
200	10	55	21.6
	16	45	55.6

Self-aligning clevis CGKD

ISO 6982

DIN 24338

ISO 8132

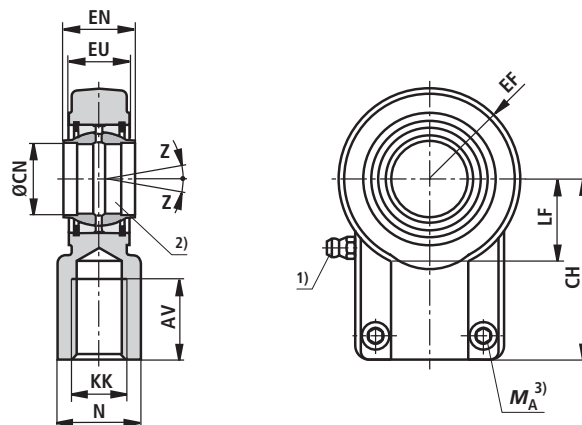

AL = Piston Ø

MM = Piston rod Ø

1) = Grease nipple cone head form A to DIN 71412

2) = Associated pin Ø r6

3) = The self-aligning clevis must always be screwed against the piston rod shoulder. Then, the clamping screws must be tightened to the specified torque.

4) = Weigh of self-aligning clevis

5) = Bearing cannot be lubricated

6) = Self-aligning clevis for piston rod end G (ISO 6020/1)

7) = Self-aligning clevis for piston rod end H (VW standard VW 39 D920)

Note:

The geometry and dimensions may vary depending on the make.

For combination with other mounting elements, the usability must be verified.

Self-aligning clevis CGKD (dimensions in mm)

AL Ø	MM Ø	Type	Material no.	Nominal force N	AV min.	N max.	CH js13	EF max.	CN H7	EN h12	EU max.
25 ⁵⁾	14 ⁶⁾ / 18 ⁷⁾	CGKD 12	R900540998	8,000	17	19	38	16.5	12	12	11
25 32	18 ⁶⁾ 18 ⁶⁾ / 22 ⁷⁾	CGKD 16	R900308559	12,500	19	22	44	20.5	16	16	14
32 40	22 ⁶⁾ 22 ⁶⁾ / 28 ⁷⁾	CGKD 20	R900308576	20,000	23	28	52	25	20	20	17.5
40 50	28 ⁶⁾ 28 ⁶⁾ / 36 ⁷⁾	CGKD 25	R900323332	32,000	29	31	65	32	25	25	22
50 63	36 ⁶⁾ 36 ⁶⁾ / 45 ⁷⁾	CGKD 32	R900322049	50,000	37	38	80	40	32	32	28
63 80	45 ⁶⁾ 45 ⁶⁾ / 56 ⁷⁾	CGKD 40	R900322029	80,000	46	47	97	50	40	40	34
80 100	56 ⁶⁾ 56 ⁶⁾ / 70 ⁷⁾	CGKD 50	R900322719	125,000	57	58	120	63	50	50	42
100 125	70 ⁶⁾ 70 ⁶⁾ / 90 ⁷⁾	CGKD 63	R900322028	200,000	64	70	140	72.5	63	63	53.5
125 160	90 ⁶⁾ 90 ⁶⁾ / 110 ⁷⁾	CGKD 80	R900322700	320,000	86	91	180	92	80	80	68
160 200	110 ⁶⁾ 110 ⁶⁾ / 140 ⁷⁾	CGKD 100	R900322030	500,000	96	110	210	114	100	100	85.5
200	140 ⁶⁾	CGKD 125	R900322026	800,000	113	135	260	160	125	125	105

AL Ø	MM Ø	Type	KK	LF min.	Clamping screw ISO 4762-10.9	M _T ³⁾ Nm	m ⁴⁾ kg	Z
25 ⁵⁾	14 ⁶⁾ / 18 ⁷⁾	CGKD 12	M12 x 1.25	13	M5 x 16	6	0.1	2°
25 32	18 ⁶⁾ 18 ⁶⁾ / 22 ⁷⁾	CGKD 16	M14 x 1.5	16.5	M6 x 14	10	0.2	2°
32 40	22 ⁶⁾ 22 ⁶⁾ / 28 ⁷⁾	CGKD 20	M16 x 1.5	20.5	M8 x 20	25	0.35	2°
40 50	28 ⁶⁾ 28 ⁶⁾ / 36 ⁷⁾	CGKD 25	M20 x 1.5	25.5	M8 x 20	25	0.65	2°
50 63	36 ⁶⁾ 36 ⁶⁾ / 45 ⁷⁾	CGKD 32	M27 x 2	30	M10 x 25	49	1.15	4°
63 80	45 ⁶⁾ 45 ⁶⁾ / 56 ⁷⁾	CGKD 40	M33 x 2	39	M10 x 30	49	2.1	4°
80 100	56 ⁶⁾ 56 ⁶⁾ / 70 ⁷⁾	CGKD 50	M42 x 2	47	M12 x 35	86	4	4°
100 125	70 ⁶⁾ 70 ⁶⁾ / 90 ⁷⁾	CGKD 63	M48 x 2	58	M16 x 40	210	7.2	4°
125 160	90 ⁶⁾ 90 ⁶⁾ / 110 ⁷⁾	CGKD 80	M64 x 3	74	M20 x 50	410	15	4°
160 200	110 ⁶⁾ 110 ⁶⁾ / 140 ⁷⁾	CGKD 100	M80 x 3	94	M24 x 60	710	25.5	4°
200	140 ⁶⁾	CGKD 125	M100 x 3	116	M24 x 70	710	52.5	4°

Fork clevis head CCKB

ISO 8132

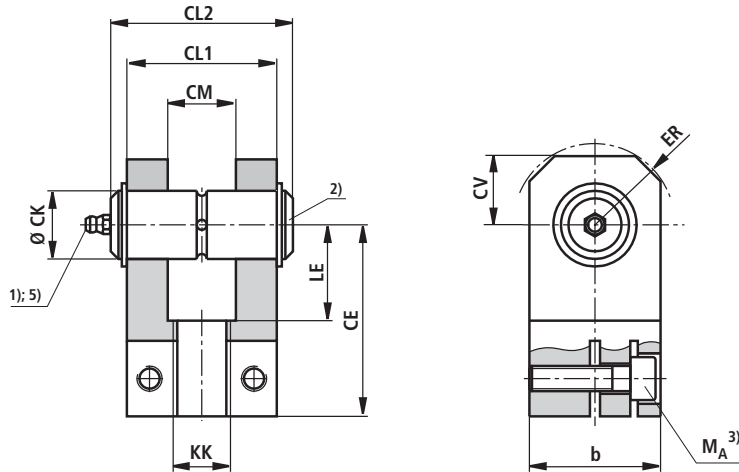

AL = Piston Ø

MM = Piston rod Ø

1) = Grease nipple cone head form A to DIN 71412

2) = Associated pin Ø m6
(Pin and pin locking feature are included in the scope of supply, but are not mounted in the factory)

3) M_T = Tightening torque
The fork clevis head must always be screwed against the piston rod shoulder. Then, the clamping screws must be tightened to the specified torque.

4) m = Weight of fork clevis head

5) = Without lubricating bore

6) = Fork clevis head for piston rod end G
(ISO 6020/1)

7) = Fork clevis head for piston rod end H
(VW standard VW 39 D920)

8) = On request

Note:

The geometry and dimensions may vary depending on the make.

For combination with other mounting elements, the usability must be verified.

Fork clevis head CCKB (dimensions in mm)

AL Ø	MM Ø	Type	Material no.	Nominal force N	b max.	CE js13	CK H9	CL1 h16	CL2 max.	CM A13	ER max.
25 ⁵⁾	14 ⁶⁾ / 18 ⁷⁾	CCKB 12	R900542842	8,000	25	38	12	28	49	12	16
25 32	18 ⁶⁾ 18 ⁶⁾ / 22 ⁷⁾	CCKB 16	R900542843	12,500	30	44	16	36	57	16	20
32 40	22 ⁶⁾ 22 ⁶⁾ / 28 ⁷⁾	CCKB 20	R900542844	20,000	40	52	20	45	72	20	25
40 50	28 ⁶⁾ 28 ⁶⁾ / 36 ⁷⁾	CCKB 25	R900542845	32,000	50	65	25	56	84	25	32
50 63	36 ⁶⁾ 36 ⁶⁾ / 45 ⁷⁾	CCKB 32	R900542846	50,000	65	80	32	70	105	32	40
63 80	45 ⁶⁾ 45 ⁶⁾ / 56 ⁷⁾	CCKB 40	R900542847	80,000	80	97	40	90	133	40	50
80 100	56 ⁶⁾ 56 ⁶⁾ / 70 ⁷⁾	CCKB 50	R900542848	125,000	100	120	50	110	165	50	63
100 125	70 ⁶⁾ 70 ⁶⁾ / 90 ⁷⁾	CCKB 63	R900542849	200,000	140	140	63	140	185	63	71
125 160	90 ⁶⁾ 90 ⁶⁾ / 110 ⁷⁾	CCKB 80	R900542850	320,000	180	180	80	170	225	80	90
160 200	110 ⁶⁾ 110 ⁶⁾ / 140 ⁷⁾	CCKB 100	8)	500,000	220	210	100	210	8)	100	110

AL Ø	MM Ø	Type	KK	LE min.	CV max.	Clamping screw ISO 4762-10.9	M _T ³⁾ Nm	m ⁴⁾ kg
25 ⁵⁾	14 ⁶⁾ / 18 ⁷⁾	CCKB 12	M12 x 1.25	18	16	M4 x 16	2.9	0.2
25 32	18 ⁶⁾ 18 ⁶⁾ / 22 ⁷⁾	CCKB 16	M14 x 1.5	22	20	M6 x 20	10	0.35
32 40	22 ⁶⁾ 22 ⁶⁾ / 28 ⁷⁾	CCKB 20	M16 x 1.5	27	25	M8 x 30	25	0.7
40 50	28 ⁶⁾ 28 ⁶⁾ / 36 ⁷⁾	CCKB 25	M20 x 1.5	34	32	M10 x 35	49	1.4
50 63	36 ⁶⁾ 36 ⁶⁾ / 45 ⁷⁾	CCKB 32	M27x 2	42	40	M12 x 40	85	2.8
63 80	45 ⁶⁾ 45 ⁶⁾ / 56 ⁷⁾	CCKB 40	M33 x 2	52	50	M16 x 50	210	5.2
80 100	56 ⁶⁾ 56 ⁶⁾ / 70 ⁷⁾	CCKB 50	M42 x 2	64	63	M20 x 60	425	9.5
100 125	70 ⁶⁾ 70 ⁶⁾ / 90 ⁷⁾	CCKB 63	M48 x 2	75	71	M24 x 80	730	21.5
125 160	90 ⁶⁾ 90 ⁶⁾ / 110 ⁷⁾	CCKB 80	M64 x 3	94	90	M30 x 100	1450	38.2
160 200	110 ⁶⁾ 110 ⁶⁾ / 140 ⁷⁾	CCKB 100	M80 x 3	120	110	M36 x 130	2480	8)

Fork-type mounting block CLCA

ISO 8132, form B

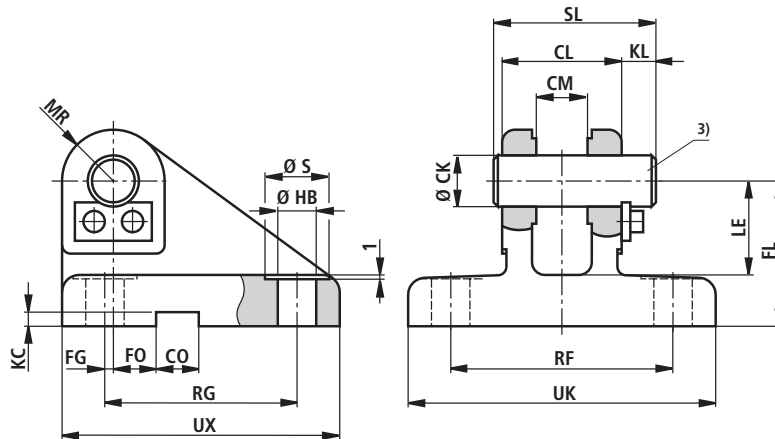

- AL = Piston Ø
- MM = Piston rod Ø
- 1) = Assignment for mounting at cap
- 2) = Assignment for mounting at self-aligning clevis CGKD
- 3) = Associated pin Ø m6
(Pin and pin locking feature are included in the scope of supply, but are not mounted in the factory)
- 4) *m* = Weight of fork-type mounting block
- 6) = Fork-type mounting block for piston rod end **G**
(ISO 6020/1)
- 7) = Fork-type mounting block for piston rod end **H**
(VW standard VW 39 D920)
- 8) = On request

Note:

The geometry and dimensions may vary depending on the make.

For combination with other mounting elements, the usability must be verified.

Fork-type mounting block CLCA (dimensions in mm)

AL ¹⁾ Ø	AL ²⁾ Ø	MM ²⁾ Ø	Type	Material no.	Nom. force N	CK H9	CL h16	CM A12	CO N9	FG js14	FL js12	FO js14
25	25	14 ⁶⁾ / 18 ⁷⁾	CLCA 12	R900542861	8,000	12	28	12	10	2	34	10
32	25 32	18 ⁶⁾ 18 ⁶⁾ / 22 ⁷⁾	CLCA 16	R900542862	12,500	16	36	16	16	3.5	40	10
40	32 40	22 ⁶⁾ 22 ⁶⁾ / 28 ⁷⁾	CLCA 20	R900542863	20,000	20	45	20	16	7.5	45	10
50	40 50	28 ⁶⁾ 28 ⁶⁾ / 36 ⁷⁾	CLCA 25	R900542864	32,000	25	56	25	25	10	55	10
63	50 63	36 ⁶⁾ 36 ⁶⁾ / 45 ⁷⁾	CLCA 32	R900542865	50,000	32	70	32	25	14.5	65	6
80	63 80	45 ⁶⁾ 45 ⁶⁾ / 56 ⁷⁾	CLCA 40	R900542866	80,000	40	90	40	36	17.5	76	6
100	80 100	56 ⁶⁾ 56 ⁶⁾ / 70 ⁷⁾	CLCA 50	R900542867	125,000	50	110	50	36	25	95	0
125	100 125	70 ⁶⁾ 70 ⁶⁾ / 90 ⁷⁾	CLCA 63	R900542868	200,000	63	140	63	50	33	112	0
160	125 160	90 ⁶⁾ 90 ⁶⁾ / 110 ⁷⁾	CLCA 80	R900542869	320,000	80	170	80	50	45	140	0
200	160 200	110 ⁶⁾ 110 ⁶⁾ / 140 ⁷⁾	CLCA 100	⁸⁾	500,000	100	210	100	63	52.5	180	0
-	200	140 ⁶⁾	CLCA 125	⁸⁾	800,000	125	270	125	80	75	230	0

AL ¹⁾ Ø	AL ²⁾ Ø	MM ²⁾ Ø	Type	HB H13	KC +0,3	KL	LE min.	MR max.	RF js14	RG js14	S	SL	UK max.	UX max.	m ⁴⁾ kg
25	25	14 ⁶⁾ / 18 ⁷⁾	CLCA 12	9	3.3	8	22	12	52	45	15	38	72	65	0.45
32	25 32	18 ⁶⁾ 18 ⁶⁾ / 22 ⁷⁾	CLCA 16	11	4.3	8	27	16	65	55	18	46	90	80	1
40	32 40	22 ⁶⁾ 22 ⁶⁾ / 28 ⁷⁾	CLCA 20	11	4.3	10	30	20	75	70	18	58	100	95	1.5
50	40 50	28 ⁶⁾ 28 ⁶⁾ / 36 ⁷⁾	CLCA 25	13.5	5.4	10	37	25	90	85	20	69	120	115	3
63	50 63	36 ⁶⁾ 36 ⁶⁾ / 45 ⁷⁾	CLCA 32	17.5	5.4	13	43	32	110	110	26	87	145	145	5
80	63 80	45 ⁶⁾ 45 ⁶⁾ / 56 ⁷⁾	CLCA 40	22	8.4	16	52	40	140	125	33	110	185	170	9.6
100	80 100	56 ⁶⁾ 56 ⁶⁾ / 70 ⁷⁾	CLCA 50	26	8.4	19	65	50	165	150	40	133	215	200	15.5
125	100 125	70 ⁶⁾ 70 ⁶⁾ / 90 ⁷⁾	CLCA 63	33	11.4	20	75	63	210	170	48	164	270	230	27.5
160	125 160	90 ⁶⁾ 90 ⁶⁾ / 110 ⁷⁾	CLCA 80	39	11.4	26	95	80	250	210	57	202	320	280	47
200	160 200	110 ⁶⁾ 110 ⁶⁾ / 140 ⁷⁾	CLCA 100	52	12.4	30	120	100	315	250	76	246	405	345	⁸⁾
-	200	140 ⁶⁾	CLCA 125	52	15.4	32	170	125	365	350	76	310	455	450	⁸⁾

Fork-type mounting block CLCD

ISO 8132, form A

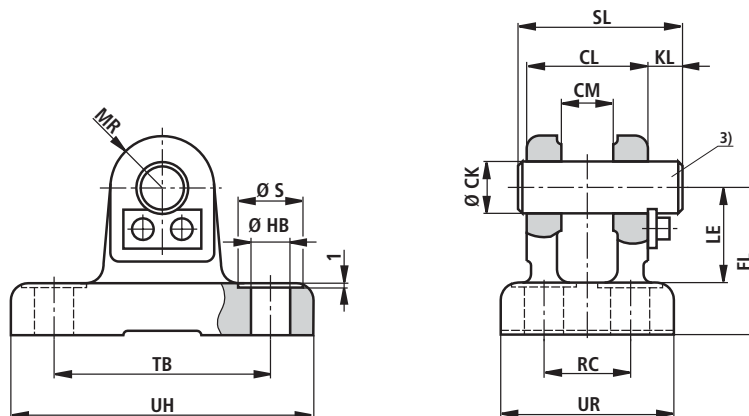

AL = Piston Ø

MM = Piston rod Ø

1) = Assignment for mounting at cap

2) = Assignment for mounting at self-aligning clevis CGKD

3) = Associated pin Ø m6
(Pin and pin locking feature are included in the scope of supply, but are not mounted in the factory)

4) *m* = Weight of fork-type mounting block

6) = Fork-type mounting block for piston rod end **G**
(ISO 6020/1)

7) = Fork-type mounting block for piston rod end **H**
(VW standard VW 39 D920)

8) = On request

Note:

The geometry and dimensions may vary depending on the make.

For combination with other mounting elements, the usability must be verified.

Fork-type mounting block CLCD (dimensions in mm)

AL ¹⁾ Ø	AL ²⁾ Ø	MM ²⁾ Ø	Type	Material no.	Nom. force N	CK H9	CL h16	CM A12	FL js12	HB H13	KL	LE min.
25	25	14 ⁶⁾ / 18 ⁷⁾	CLCD 12	R900542879	8,000	12	28	12	34	9	8	22
32	25 32	18 ⁶⁾ 18 ⁶⁾ / 22 ⁷⁾	CLCD 16	R900542880	12,500	16	36	16	40	11	8	27
40	32 40	22 ⁶⁾ 22 ⁶⁾ / 28 ⁷⁾	CLCD 20	R900542881	20,000	20	45	20	45	11	10	30
50	40 50	28 ⁶⁾ 28 ⁶⁾ / 36 ⁷⁾	CLCD 25	R900542882	32,000	25	56	25	55	13.5	10	37
63	50 63	36 ⁶⁾ 36 ⁶⁾ / 45 ⁷⁾	CLCD 32	R900542883	50,000	32	70	32	65	17.5	13	43
80	63 80	45 ⁶⁾ 45 ⁶⁾ / 56 ⁷⁾	CLCD 40	R900542884	80,000	40	90	40	76	22	16	52
100	80 100	56 ⁶⁾ 56 ⁶⁾ / 70 ⁷⁾	CLCD 50	R900542885	125,000	50	110	50	95	26	19	65
125	100 125	70 ⁶⁾ 70 ⁶⁾ / 90 ⁷⁾	CLCD 63	R900542886	200,000	63	140	63	112	33	20	75
160	125 160	90 ⁶⁾ 90 ⁶⁾ / 110 ⁷⁾	CLCD 80	R900542887	320,000	80	170	80	140	39	26	95
200	160 200	110 ⁶⁾ 110 ⁶⁾ / 140 ⁷⁾	CLCD 100	⁸⁾	500,000	100	210	100	180	52	30	120
-	200	140 ⁶⁾	CLCD 125	⁸⁾	800,000	125	270	125	230	52	32	170

AL ¹⁾ Ø	AL ²⁾ Ø	MM ²⁾ Ø	Type	MR max.	RC js14	S	SL	TB js14	UR max.	UH max.	m ⁴⁾ kg
25	25	14 ⁶⁾ / 18 ⁷⁾	CLCD 12	12	20	15	38	50	40	70	0.35
32	25 32	18 ⁶⁾ 18 ⁶⁾ / 22 ⁷⁾	CLCD 16	16	26	18	46	65	50	90	0.7
40	32 40	22 ⁶⁾ 22 ⁶⁾ / 28 ⁷⁾	CLCD 20	20	32	18	58	75	58	98	0.95
50	40 50	28 ⁶⁾ 28 ⁶⁾ / 36 ⁷⁾	CLCD 25	25	40	20	69	85	70	113	1.9
63	50 63	36 ⁶⁾ 36 ⁶⁾ / 45 ⁷⁾	CLCD 32	32	50	26	87	110	85	143	3
80	63 80	45 ⁶⁾ 45 ⁶⁾ / 56 ⁷⁾	CLCD 40	40	65	33	110	130	108	170	5.5
100	80 100	56 ⁶⁾ 56 ⁶⁾ / 70 ⁷⁾	CLCD 50	50	80	40	133	170	130	220	10.6
125	100 125	70 ⁶⁾ 70 ⁶⁾ / 90 ⁷⁾	CLCD 63	63	100	48	164	210	160	270	17
160	125 160	90 ⁶⁾ 90 ⁶⁾ / 110 ⁷⁾	CLCD 80	80	125	57	202	250	210	320	32
200	160 200	110 ⁶⁾ 110 ⁶⁾ / 140 ⁷⁾	CLCD 100	100	160	76	246	315	260	400	⁸⁾
-	200	140 ⁶⁾	CLCD 125	125	200	76	310	385	320	470	⁸⁾

Trunnion mounting block CLTB (dimensions in mm)

ISO 8132

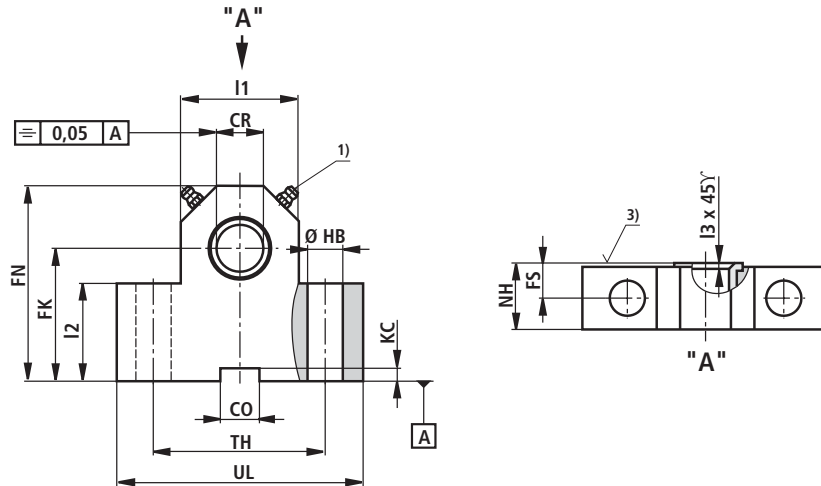

AL Ø	Type	Material no.	Nominal force N	CR H7	CO N9	FK js12	FN max,	FS js14	HB H13	KC +0.3	I1	I2
25	CLTB 12	R900772607 ⁴⁾	8,000	12	10	34	50	8	9	3.3	24	25
32	CLTB 16	R900772608 ⁴⁾	12,500	16	16	40	60	10	11	4.3	31	30
40	CLTB 20	R900772609 ⁴⁾	20,000	20	16	45	70	10	11	4.3	41	38
50	CLTB 25	R900772610 ⁴⁾	32,000	25	25	55	80	12	13.5	5.4	56	45
63	CLTB 32	R900772611 ⁴⁾	50,000	32	25	65	100	15	17.5	5.4	70	52
80	CLTB 40	R900772612 ⁴⁾	80,000	40	36	76	120	16	22	8.4	88	60
100	CLTB 50	R900772613 ⁴⁾	125,000	50	36	95	140	20	26	8.4	105	75
125	CLTB 63	R900772614 ⁴⁾	200,000	63	50	112	180	25	33	11.4	130	85
160	CLTB 80	R900772615 ⁴⁾	320,000	80	50	140	220	31	39	11.4	170	112
200	CLTB 100	^{8); 4)}	500,000	100	63	180	280	45	52	12.4	215	⁸⁾

AL Ø	Type	I3	NH max.	TH js14	UL max.	m ²⁾ kg
25	CLTB 12	1	17	40	63	0.4
32	CLTB 16	1	21	50	80	0.85
40	CLTB 20	1.5	21	60	90	1.2
50	CLTB 25	1.5	26	80	110	2.1
63	CLTB 32	2	33	110	150	4.55
80	CLTB 40	2.5	41	125	170	7.3
100	CLTB 50	2.5	51	160	210	14.5
125	CLTB 63	3	61	200	265	23.1
160	CLTB 80	3.5	81	250	325	52.3
200	CLTB 100	3.5	102	295	385	⁸⁾

AL = Piston Ø

1) = Grease nipple cone head form A to DIN 71412

2) m = Weight of trunnion mounting block (indication per pair)

3) = Contact face of trunnion (inside)

4) = Mounting blocks are always delivered in pairs

8) = On request

Note:

Mounting blocks for piston Ø 160 and 200 mm

For spare parts (series 1X), dimensions are different.
Please consult us!

The geometry and dimensions may vary depending on the make.

For combination with other mounting elements, the usability
must be verified.

Buckling

The permissible stroke length with a flexibly guided load and a factor of 3.5 for safety against buckling can be found in the relevant table. For other installation positions of the cylinder, the permissible stroke length must be interpolated. Permissible stroke length for non-guided load on request.

Buckling calculations are carried out according to the following formulas:

1. Calculation according to Euler

$$F = \frac{\pi^2 \cdot E \cdot I}{v \cdot L_K^2} \text{ if } \lambda > \lambda_g$$

2. Calculation according to Tetmajer

$$F = \frac{d^2 \cdot \pi \cdot (335 - 0.62 \cdot \lambda)}{4 \cdot v} \text{ if } \lambda \leq \lambda_g$$

Explanation:

E = Modulus of elasticity in N/mm²

= 2.1 x 10⁵ for steel

I = Geometrical moment of inertia in mm⁴ for circular

$$\text{cross-section} = \frac{d^4 \cdot \pi}{64} = 0.0491 \cdot d^4$$

v = 3.5 (safety factor)

L_K = Free buckling length in mm (depending on mounting type, see sketches A, B, C)

d = Piston rod Ø in mm

λ = Slenderness ratio

$$= \frac{4 \cdot L_K}{d} \quad \lambda_g = \pi \sqrt{\frac{E}{0.8 \cdot R_e}}$$

R_e = Yield strength of piston rod material

Influence on the mounting type on the buckling length:

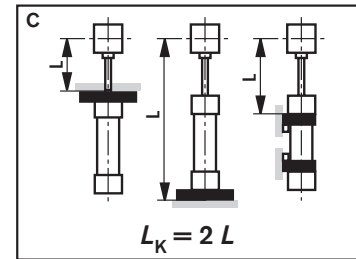
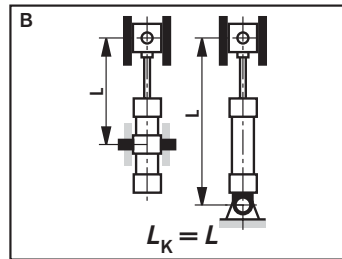
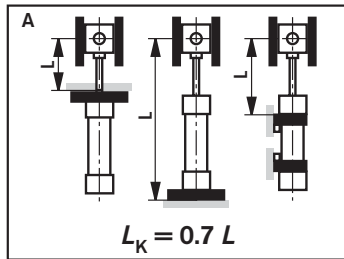

Permissible stroke length (dimensions in mm)

Mounting type MF2, MF4, MT4 trunnion (with XV_{max})

AL Ø	MM Ø	Permissible stroke length at									Max. available stroke length	Installation position
		70 bar			100 bar			160 bar				
		0°	45°	90°	0°	45°	90°	0°	45°	90°		
25	14 18	260	270	305	215	220	240	160	165	170	600	0°
		435	455	485	385	400	460	310	315	340		
32	18 22	340	355	410	290	295	325	215	220	230	800	
		510	535	665	450	465	535	365	370	400		
40	22 28	405	425	495	345	355	395	265	270	285	1000	90°
		640	680	875	575	600	710	475	490	535		
50	28 36	540	560	665	465	480	535	365	370	390	1200	
		845	895	1180	765	805	970	645	665	735		
63	36 45	705	740	900	620	640	725	500	510	540	1400	90°
		1030	1100	1480	945	990	1220	805	830	930		
80	45 56	855	900	1120	760	790	905	615	630	680	1700	
		1230	1310	1700	1130	1190	1490	975	1010	1140		
100	56 70	1030	1090	1390	925	965	1130	760	780	850	2000	90°
		1500	1590	2000	1380	1460	1880	1200	1250	1440		
125	70 90	1280	1360	1770	1160	1210	1450	970	995	1090	2300	
		1900	2030	2300	1770	1880	2300	1570	1640	1950		
160	90 110	1620	1710	2320	1470	1540	1900	1250	1290	1440	2600	90°
		2200	2350	2600	2060	2180	2600	1820	1900	2280		
200	110 140	1890	2010	2760	1730	1820	2260	1470	1520	1720	3000	
		2720	2910	3000	2560	2720	3000	2290	2400	2980		

¹⁾ Permissible stroke

Permissible stroke length (dimensions in mm)

Mounting type MF1, MF3, MS2

AL Ø	MM Ø	Permissible stroke length at									Max. available stroke length	Installation position
		70 bar			100 bar			160 bar				
		0°	45°	90°	0°	45°	90°	0°	45°	90°		
25	14	350	355	380	300	305	315	235	240	240	600	0°
	18	530	550	645	470	485	535	390	400	415		
32	18	445	455	495	385	390	410	310	315	320	800	0°
	22	615	640	660	550	570	625	460	465	490		
40	22	530	545	590	460	470	490	370	375	380	1000	45°
	28	775	810	980	700	725	815	590	600	635		
50	28	670	690	770	590	600	640	475	485	495	1200	45°
	36	975	1020	1300	890	925	1080	765	785	845		
63	36	845	880	1000	750	770	830	615	625	645	1400	45°
	45	1170	1230	1400	1070	1120	1330	920	950	1040		
80	45	1020	1060	1240	910	935	1020	750	765	795	1700	45°
	56	1390	1470	1700	1280	1340	1620	1110	1150	1270		
100	56	1240	1290	1540	1110	1150	1280	930	940	990	2000	90°
	70	1680	1780	2000	1560	1640	2000	1370	1410	1590		
125	70	1510	1570	1920	1360	1400	1590	1140	1160	1240	2300	90°
	90	2090	2220	2300	1960	2060	2300	1740	1810	2110		
160	90	1880	1980	2500	1720	1780	2070	1460	1500	1610	2600	90°
	110	2430	2580	2600	2280	2400	2600	2600	2110	2460		
200	110	2210	2320	2980	2020	2100	2470	1730	1770	1920	3000	90°
	140	2980	3000	3000	2810	2980	3000	2540	2650	3000		

1) Permissible stroke

Mounting type: MP3, MP5

AL Ø	MM Ø	Permissible stroke length at									Max. available stroke length	Installation position
		70 bar			100 bar			160 bar				
		0°	45°	90°	0°	45°	90°	0°	45°	90°		
25	14	155	160	175	120	125	130	75	80	85	600	0°
	18	300	310	360	250	260	285	190	195	220		
32	18	210	220	240	165	170	180	110	115	120	800	0°
	22	345	360	420	290	300	330	220	225	235		
40	22	255	265	295	205	210	225	140	145	150	1000	45°
	28	445	465	560	385	395	445	295	305	320		
50	28	350	360	405	285	290	315	205	210	215	1200	45°
	36	600	630	770	525	540	615	415	425	455		
63	36	470	490	560	395	405	440	290	292	310	1400	45°
	45	740	780	970	650	680	780	525	535	580		
80	45	575	600	700	490	505	555	370	375	390	1700	45°
	56	890	935	1190	790	820	960	640	660	715		
100	56	705	735	880	600	620	695	460	470	495	2000	90°
	70	1085	1150	1500	970	1015	1215	800	825	910		
125	70	890	935	1135	770	800	905	605	615	655	2300	90°
	90	1400	1490	2030	1270	1340	1660	1070	1110	1250		
160	90	1130	1190	1490	990	1030	1190	790	810	870	2600	90°
	110	1620	1720	2370	1470	1550	1930	1240	1290	1450		
200	110	1320	1390	1770	1160	1210	1420	930	955	1040	3000	90°
	140	2010	2140	3000	1850	1950	2520	1580	1650	1910		

1) Permissible stroke

End position cushioning

End position cushioning:

The objective is to reduce the velocity of a moved mass, whose centre of gravity lies on the cylinder axis, to a level, at which neither the cylinder nor the machine, into which the cylinder is installed, is damaged. For velocities above 20 mm/s we recommend the use of an end position cushioning feature, which absorbs energy without requiring the use of additional equipment. It must, however, always be verified, whether end position cushioning is also required in the case of lower velocities with large masses.

Cushioning capacity:

When decelerating masses via end position cushioning, the design-inherent cushioning capacity must not be exceeded. Cylinders with end position cushioning can achieve their full cushioning capacity only over the entire stroke length.

With the adjustable end position cushioning variant "E", a throttle valve is provided additionally when compared with variant "D". End position cushioning variant "E" allows cycle times to be optimised. The max. cushioning capacity can only be achieved when the throttle valve is closed.

The calculation depends on the factors of weight, velocity, system pressure and installation position. For this reason, the variable D_m is derived from the mass and the velocity, and variable D_p from the system pressure and installation position. These two variables are used for verifying the permissible cushioning

performance in the diagram "cushioning capacity". The intersection point of variables D_m and D_p must always be below the cushioning capacity curve of the selected cylinder. The values in the diagrams refer to an average oil temperature of + 45 to +65 °C with the throttle valve being closed.

For special applications with very short stroke times, high velocities or large masses, cylinders with special end position cushioning variants can be offered on request.

When fixed or adjustable limit stops are used, special measures must be taken!

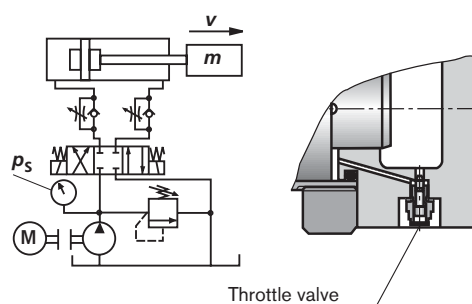

Formulas:

$$D_m = \frac{m}{10^k}; K = kv(0.5-v)$$

m = moved mass in kg

v = stroke velocity in m/s

kv = see table on page 58

Extending:

$$D_p = p_s - \frac{m \cdot 9.81 \cdot \sin \alpha}{A_1 \cdot 10}$$

Retracting:

$$D_p = p_s + \frac{m \cdot 9.81 \cdot \sin \alpha}{A_3 \cdot 10}$$

p_s = system pressure in bar

A_1 = piston area in cm^2 (see page 3)

A_3 = annulus area in cm^2 (see page 3)

α = angle in degree in relation to the horizontal plane

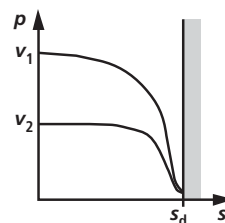
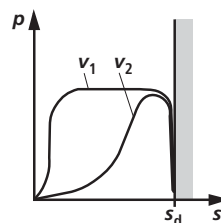
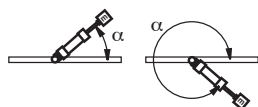

Cushioning length

AL Ø mm	25	32	40	50	63	80	100	125	160	200
Head side	15	19	23	22	27	27	32	33	40	46
Cap side	15	19	23	22	27	27	32	33	40	46

End position cushioning / cushioning capacity

AL Ø mm	25	32	40	50	63	80	100	125	160	200
kv ①	2.97	2.56	2.82	3.51	3.02	2.53	2.65	2.91	2.76	2.95
kv ②	3.15	2.93	2.95	3.45	2.95	2.53	2.93	2.95	2.95	3.1
kv ③	3.1	2.73	3.1	3.51	2.95	2.51	2.91	2.95	2.91	2.93

Cushioning capacity: Extending

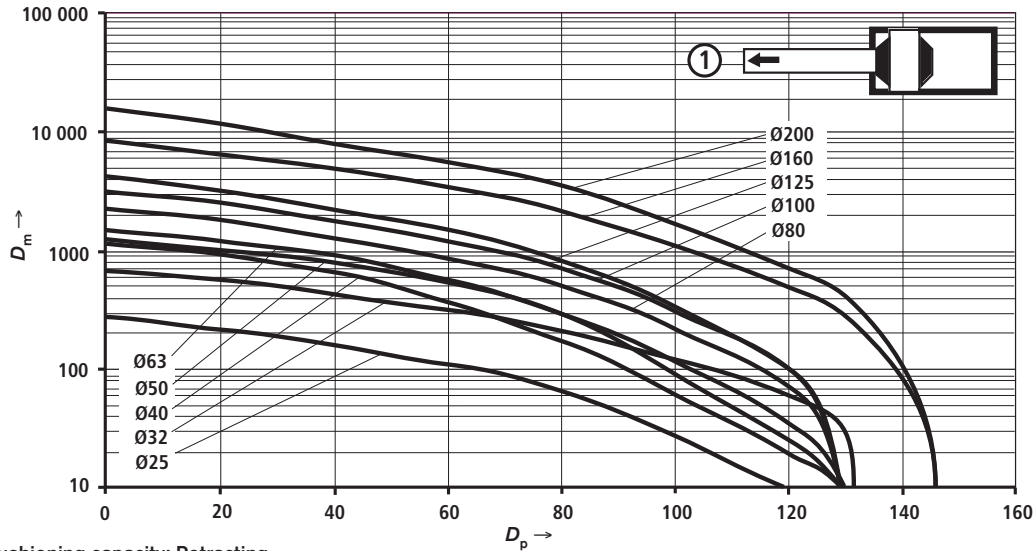

Cushioning capacity: Retracting

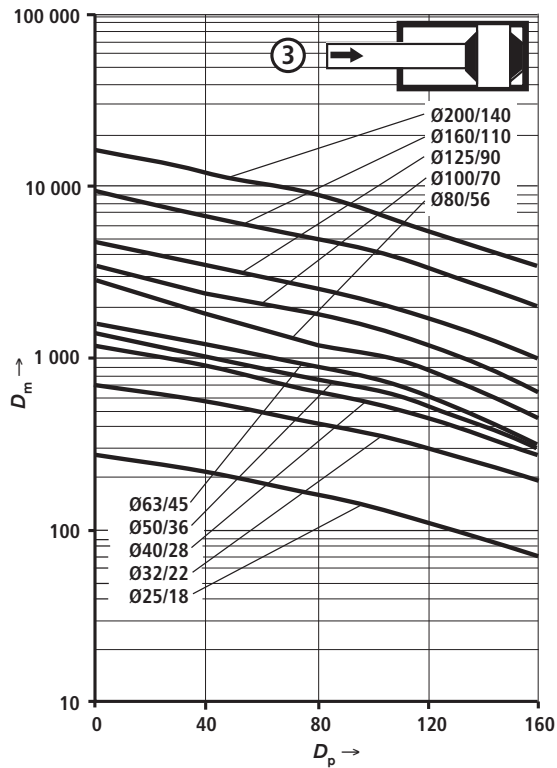
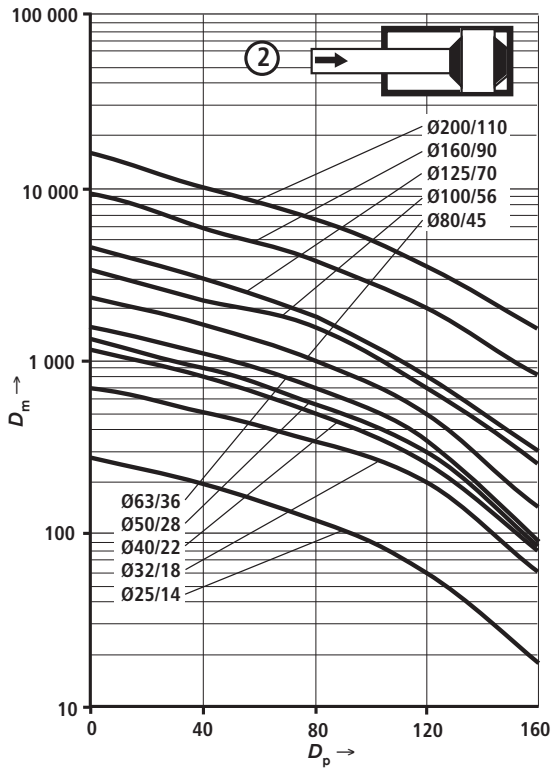

Bleeding / threaded coupling (dimensions in mm)

For piston $\varnothing \geq 40$ mm, a patented safety bleed feature, which is protected against unintended turning out, is provided at the head and the cap as a standard.

For piston $\varnothing 25$ and 32 mm, a G1/8 bleed screw is installed at the head and the cap, which is **not** secured.

The port allows the installation of a threaded coupling with check valve for pressure measurements or contamination-free bleeding. The threaded coupling features a check valve function, that is, it can also be connected under pressure.

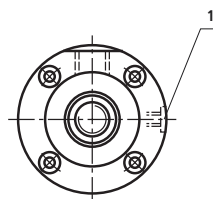

1) = Bleeding: When viewed to the piston rod, the position is always offset by 90° to the pipe port (clockwise)

Connection option for threaded coupling

Piston \varnothing (AL) 25 and 32 mm

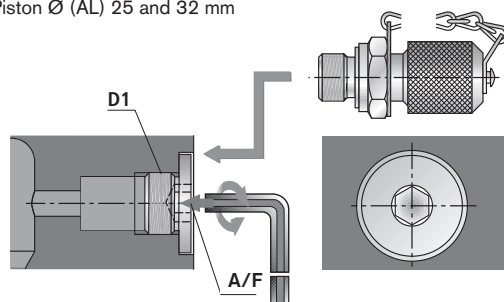

Piston \varnothing (AL) 40 to 200 mm

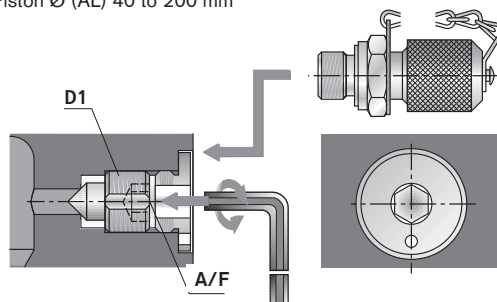

AL \varnothing	D1	Bleed screw		Threaded coupling	
		Securing	A/F	D2	
25 and 32	G1/8	Not secured	5	G1/8	
40 and 50	G1/8	Secured	5	G1/8	
63 to 200	G1/4	Secured	6	G1/4	

Scope of supply: Threaded coupling **G1/8**

SCHRAUBKUPPLUNG AB 20-11/K3 G1/8 with seal ring made of NBR

Material no. **R900014363**

SCHRAUBKUPPLUNG AB 20-11/K3V G1/8 with seal ring made of FKM

Material no. **R900024710**

Scope of supply: Threaded coupling **G1/4**

SCHRAUBKUPPLUNG AB 20-11/K1 G1/4 with seal ring made of NBR

Material no. **R900009090**

SCHRAUBKUPPLUNG AB 20-11/K1V G1/4 with seal ring made of FKM

Material no. **R900001264**

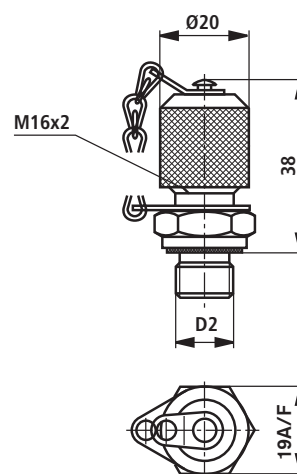

Throttle valve (dimensions in mm)

AL \varnothing	25	32	40	50	63	80	100	125	160	200
Projection A ¹⁾	6.5	4	5.5	1.5	0	0	0	0	0	0

AL = Piston \varnothing

¹⁾ = Throttle valve only for end position cushioning "E" (180° for bleeding)

Protrusion A in the closed condition

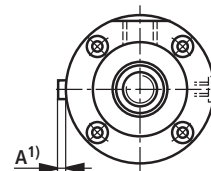

Seal (piston rod/piston)

Variants "M and V"

Piston Ø (AL) 25 and 32 mm

Piston rod seal

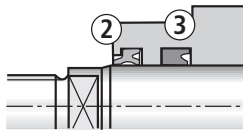

Piston seal

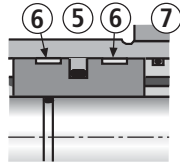

Piston Ø (AL) 40 to 200 mm

Piston rod seal

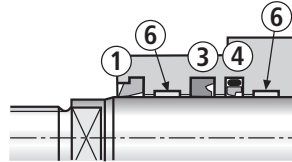

Piston seal

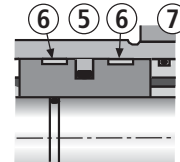

Variants "T and S"

Piston Ø (AL) 40 to 200 mm

Piston rod seal

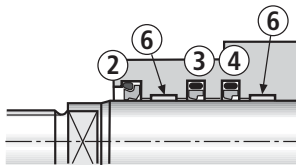

Piston seal

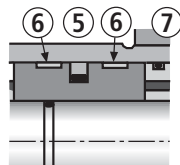

Variants "A"

Piston Ø (AL) 50 to 200 mm

Piston rod seal

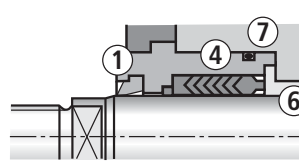

Piston seal

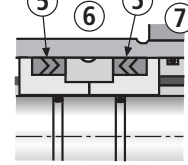

Medium	Seal variant	Compatibility with media / seal materials						
		① Wiper	② Double wiper		③ Piston rod seal		④ Piston rod seal (primary)	⑤ Piston seal
			Piston Ø 25 and 32	Piston Ø 40 to 200	Piston Ø 25 and 32	(secondary) Piston Ø 40 to 200		
HL, HLP	M	TPE	AU	-	AU	AU	PTFE / NBR	TPE / NBR
HL, HLP, HFA, HFC	T	-	-	PTFE / NBR	-	PTFE / NBR	PTFE / NBR	PTFE / NBR
HFD-R	V	TPE	FKM	-	FKM	PTFE / FKM	PTFE / FKM	PTFE / FKM
HFD-R	S	-	-	PTFE / FKM	-	PTFE / FKM	PTFE / FKM	PTFE / FKM
HL, HLP, HFA, HFC	A	TPE	-	-	-	-	POM / NBR	POM / NBR

Medium	Seal variant	⑥ Guide	⑦ O-ring	Features
HL, HLP, HFA, HFC	T	Fibre compound	NBR	Low friction
HFD-R	V	Fibre compound	FKM	High temperature
HFD-R	S	Fibre compound	FKM	Low friction and high temperature
HL, HLP, HFA, HFC	A	Red cast iron	NBR	Holding function

HL, HLP: -20 °C to +80 °C

HFA: +5 °C to +55 °C

HFC: -20 °C to +60 °C

HFD-R: -15 °C to +120 °C

Spare parts: Series CDM1

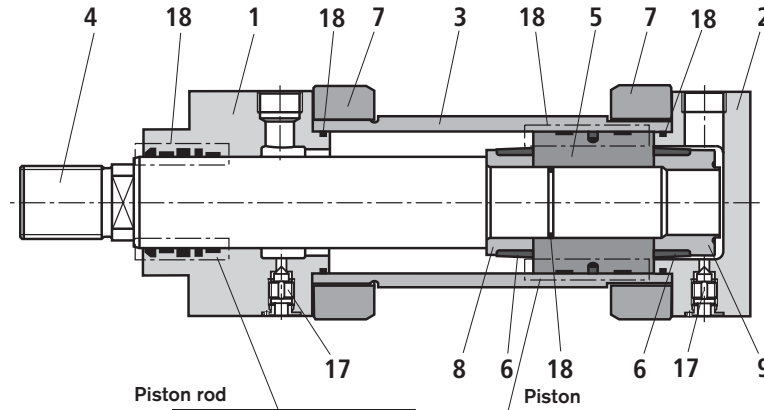

Seals "M and V"
Piston Ø (AL) 25 and 32

Seals "M and V"
Piston Ø (AL) 40 to 200

Seals "T and S"

Seal "A"

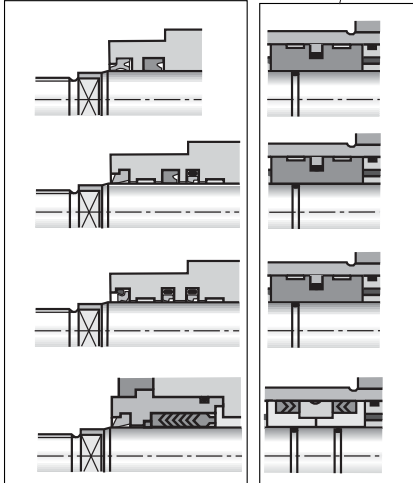

- 1 Head
- 2 Cap
- 3 Barrel
- 4 Piston rod
- 5 Piston
- 6 Cushioning bush
- 7 Flange
- 8 Bush
- 9 Bush
- 10 Cap MP3
- 11 Cap MP5
- 12 Round flange MF3
- 12.1 Rectangular flange MF1
- 13 Round flange MF4
- 13.1 Rectangular flange MF2
- 14 Trunnion MT4
- 15 Foot MS2
- 17 Bleed point
- 18 Seal kit:
Wiper
Piston rod seal
Piston seal
O-ring
Back-up ring
Guide ring

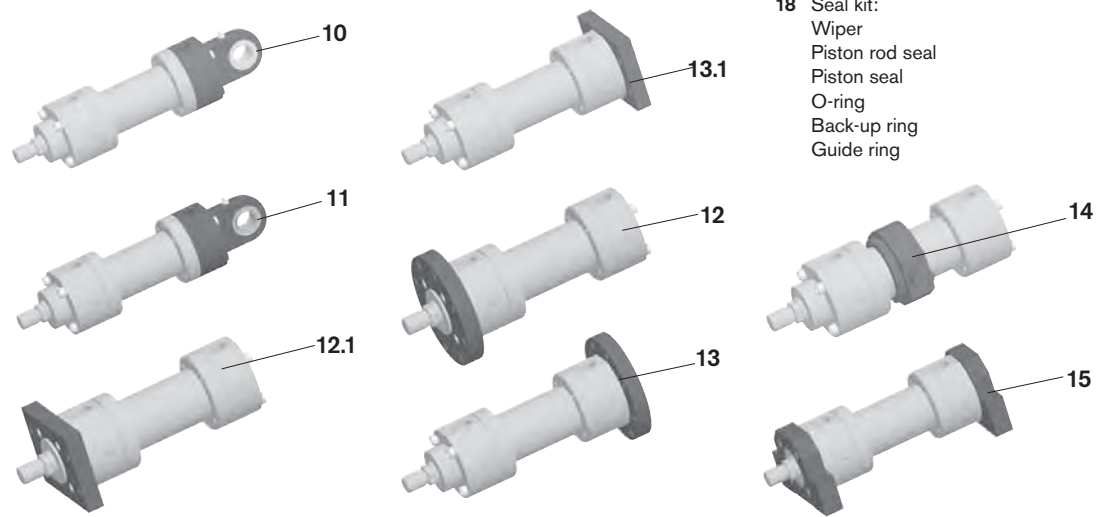

Spare parts: Series CGM1

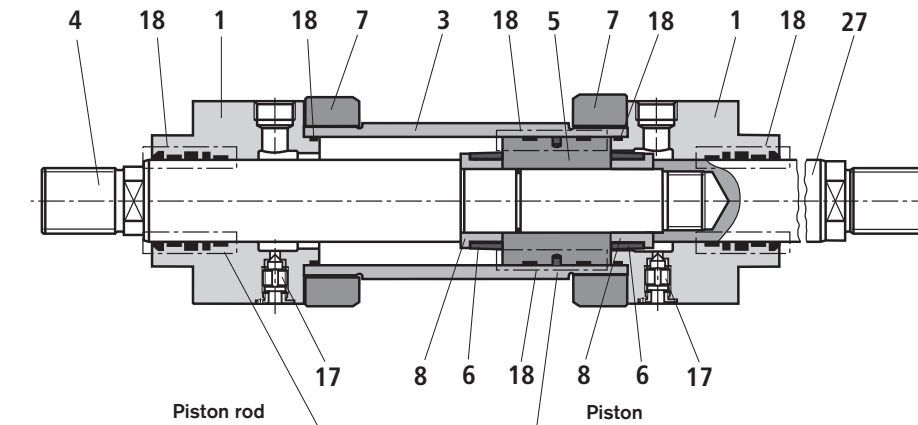

Seals "M and V"
Piston Ø (AL) 25 and 32

Seals "M and V"
Piston Ø (AL) 40 to 200

Seals "T and S"

Seal "A"

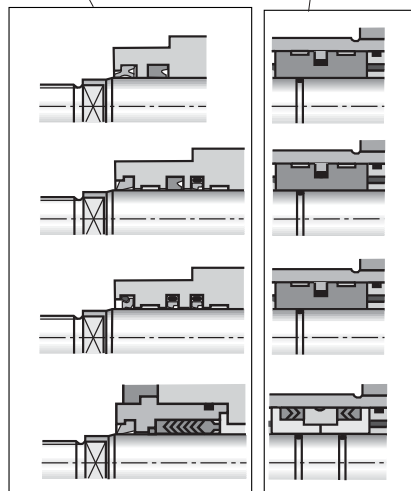

- 1 Head
- 3 Barrel
- 4 Piston rod
- 5 Piston
- 6 Cushioning bush
- 7 Flange
- 8 Bush
- 12 Round flange MF3
- 12.1 Rectangular flange MF1
- 14 Trunnion MT4
- 15 Foot MS2
- 17 Bleed point
- 18 Seal kit:
Wiper
Piston rod seal
Piston seal
O-ring
Guide ring
- 27 Piston rod

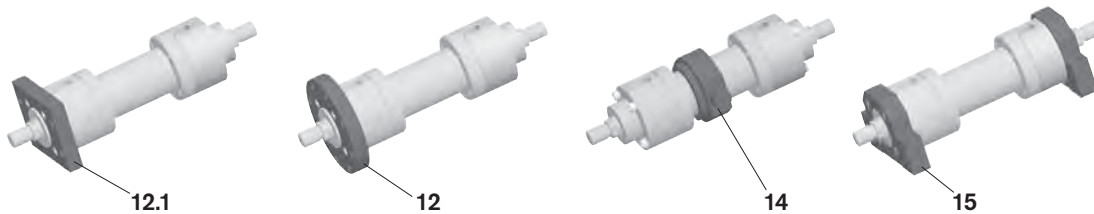

Spare parts: Series CSM1 MP3 and MP5

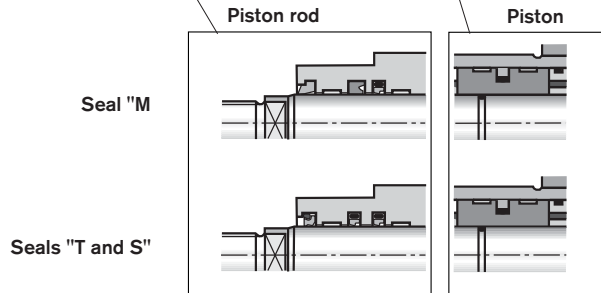
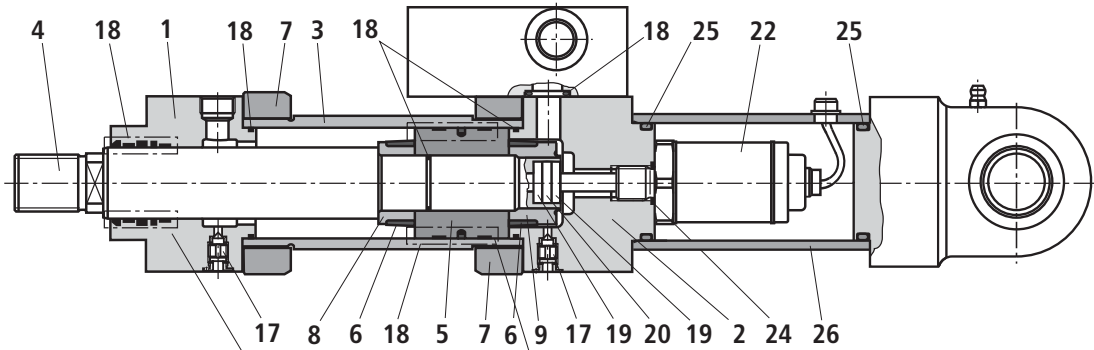

- 1 Head
- 2 Cap
- 3 Barrel
- 4 Piston rod
- 5 Piston
- 6 Cushioning bush
- 7 Flange
- 8 Bush
- 9 Bush
- 17 Bleed point
- 18 Seal kit:
Wiper
Piston rod seal
Piston seal
O-ring
Back-up ring
Guide ring
- 19 Insulating bush
- 20 Magnet
- 22 Position transducer
- 24 Seal
- 25 Seal
- 26 Protective tube

CSM1 MP3
Plain clevis at cap



CSM1 MP5
Self-aligning clevis at cap



Spare parts: Series CSM1 MF, MT4 and MS2

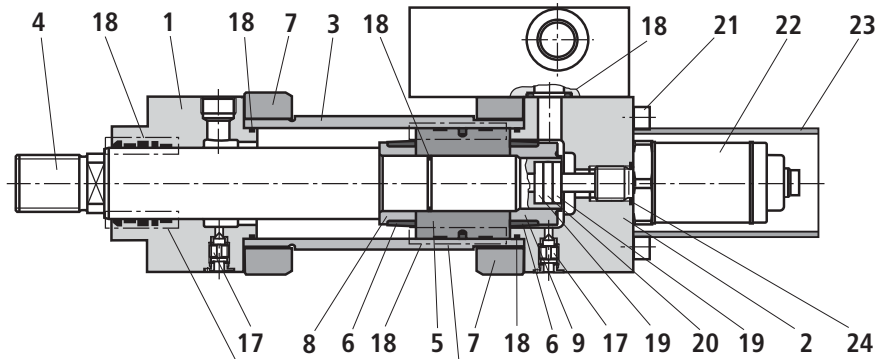

Piston rod

Piston

Seal "M"

Seals "T and S"

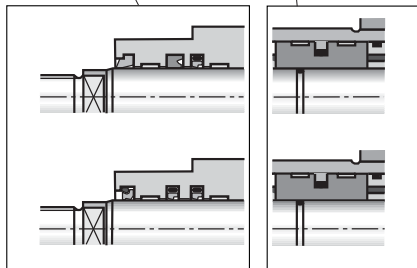

- 1 Head
- 2 Cap
- 3 Barrel
- 4 Piston rod
- 5 Piston
- 6 Cushioning bush
- 7 Flange
- 8 Bush
- 9 Bush
- 17 Bleed point
- 18 Seal kit:
Wiper
Piston rod seal
Piston seal
O-ring
Back-up ring
Guide ring
- 19 Insulating bush
- 20 Magnet
- 21 Hexagon socket head cap screw
- 22 Position transducer
- 23 Protective tube
- 24 Seal

CSM1 MF1
Rectangular flange at head



CSM1 MF3
Round flange at head



CSM1 MT4
Trunnion



CSM1 MS2
Foot mounting



Seal kits: Series CDM1 ¹⁾ / CSM1 ²⁾

AL Ø	MM Ø	Material no. for seal variant				
		M	T	V	S	A
25	14	R407026468	-	R407026567	-	-
	18	R407026529	-	R407026568	-	-
32	18	R407026530	-	R407026569	-	-
	22	R407026531	R407026548	R407026570	R407026587	-
40	22	R407026532	R407026549	R407026571	R407026588	-
	28	R407026533	R407026550	R407026572	R407026589	-
50	28	R407026534	R407026551	R407026573	R407026590	R407026604
	36	R407026535	R407026552	R407026574	R407026591	R407026605
63	36	R407026536	R407026553	R407026575	R407026592	R407026606
	45	R407026537	R407026554	R407026576	R407026593	R407026607
80	45	R407026538	R407026555	R407026577	R407026594	R407026608
	56	R407026539	R407026556	R407026578	R407026595	R407026609
100	56	R407026540	R407026557	R407026579	R407026596	R407026610
	70	R407026541	R407026558	R407026580	R407026597	R407026611
125	70	R407026542	R407026559	R407026581	R407026598	R407026612
	90	R407026543	R407026560	R407026582	R407026599	R407026613
160	90	R407026544	R407026561	R407026583	R407026600	R407026614
	110	R407026545	R407026562	R407026584	R407026601	R407026615
200	110	R407026546	R407026563	R407026585	R407026602	R407026616
	140	R407026547	R407026564	R407026586	R407026603	R407026617

AL = Piston Ø in mm

MM = Piston rod Ø in mm

¹⁾ = Seal kits for proximity switches, separate Material no., see page 66

²⁾ = Seal kits for position transducers, separate Material no., see page 66

Seal kits: Series CGM1 ³⁾

AL Ø	MM Ø	Material no. for seal variant				
		M	T	V	S	A
25	14	R407026792	-	R407026829	-	-
	18	R407026793	-	R407026830	-	-
32	18	R407026794	-	R407026831	-	-
	22	R407026795	R407026812	R407026832	R407026849	-
40	22	R407026796	R407026813	R407026833	R407026850	-
	28	R407026797	R407026814	R407026834	R407026851	-
50	28	R407026798	R407026815	R407026835	R407026852	R407026866
	36	R407026799	R407026816	R407026836	R407026853	R407026867
63	36	R407026800	R407026817	R407026837	R407026854	R407026868
	45	R407026801	R407026818	R407026838	R407026855	R407026869
80	45	R407026802	R407026819	R407026839	R407026856	R407026870
	56	R407026803	R407026820	R407026840	R407026857	R407026871
100	56	R407026804	R407026821	R407026841	R407026858	R407026872
	70	R407026805	R407026822	R407026842	R407026859	R407026873
125	70	R407026806	R407026823	R407026843	R407026860	R407026874
	90	R407026807	R407026824	R407026844	R407026861	R407026875
160	90	R407026808	R407026825	R407026845	R407026862	R407026876
	110	R407026809	R407026826	R407026846	R407026863	R407026877
200	110	R407026810	R407026827	R407026847	R407026864	R407026878
	140	R407026811	R407026828	R407026848	R407026865	R407026879

³⁾ = Seal kits for proximity switches, separate Material no., see below

Only for proximity switch

AL Ø	Material no. for seal variant	
	M, T, A	V, S
25 and 32	-	-
40 to 200	R900885938	R900885939

Only for position transducer

AL Ø	Material no. for seal variant		
	M	T	S
40	R407026769		R407026777
50	R407026770		R407026778
63	R407026771		R407026779
80	R407026772		R407026780
100	R407026773		R407026781
125	R407026774		R407026782
160	R407026775		R407026783
200	R407026776		R407026784

AL = Piston Ø in mm

MM = Piston rod Ø in mm

Tightening torques

Screws: Head and cap
(items 1 and 2)

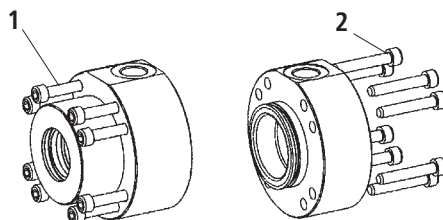

Series	Piston Ø	Screw	Qty	Grade	Tightening torque
CDM1 / CGM1 / CSM1	25	M6	4	10.9	13 Nm
CDM1 / CGM1 / CSM1	32	M6	4	10.9	13 Nm
CDM1 / CGM1 / CSM1	40	M6	4	10.9	13 Nm
CDM1 / CGM1 / CSM1	50	M8	4	10.9	30 Nm
CDM1 / CGM1 / CSM1	63	M10	4	10.9	60 Nm
CDM1 / CGM1 / CSM1	80	M10	8	10.9	50 Nm
CDM1 / CGM1 / CSM1	100	M10	8	10.9	60 Nm
CDM1 / CGM1 / CSM1	125	M12	12	10.9	100 Nm
CDM1 / CGM1 / CSM1	160	M12	16	10.9	100 Nm
CDM1 / CGM1 / CSM1	200	M16	16	10.9	200 Nm

Cylinder weight

Piston AL Ø mm	Piston rod MM Ø mm	CD / CS cylinder at 0 mm stroke length								Per 100 mm stroke length kg	CG cylinder at 0 mm stroke length				Per 100 mm stroke length kg
		M00 kg	MP3 ¹⁾ MP5 ¹⁾ kg	MP3 ²⁾ MP5 ²⁾ kg	MF1 MF2 kg	MF3 MF4 kg	MT4 kg	MS2 kg	MF1 kg		MF3 kg	MT4 kg	MS2 kg		
25	14	2.2	2.3	–	2.6	2.7	2.6	3.2	0.5	3.0	3.1	3.0	3.6	0.6	
	18	2.2	2.3	–	2.6	2.7	2.6	3.2	0.6	3.0	3.1	3.0	3.6	0.8	
32	18	3.1	3.3	–	3.8	4.0	3.7	4.7	0.7	4.3	4.5	4.2	5.2	0.9	
	22	3.1	3.3	–	3.8	4.0	3.7	4.7	0.8	4.3	4.5	4.2	5.2	1.1	
40	22	5.5	5.9	–	6.4	6.7	6.5	7.6	0.9	7.1	7.5	7.3	8.4	1.2	
	28	5.6	6.0	10.2	6.5	6.8	6.6	7.7	1.1	7.1	7.5	7.3	8.4	1.5	
50	28	8.1	8.9	14.4	9.7	10.2	9.8	12.0	1.2	11.0	11.5	11.1	13.3	1.7	
	36	8.3	9.1	14.6	9.9	10.4	10.0	12.2	1.5	11.0	11.5	11.1	13.3	2.3	
63	36	14.0	15.5	25.0	17.0	17.5	17.0	20.0	2.1	18.5	19.0	18.5	22.0	2.9	
	45	14.0	15.5	25.0	17.0	17.5	17.0	20.0	2.6	18.5	19.0	18.5	22.0	3.8	
80	45	20.0	22.5	30.5	24.0	25.0	24.0	29.0	2.9	27.0	28.0	27.0	32.0	4.1	
	56	20.0	22.5	30.5	24.0	25.0	24.0	29.0	3.6	27.0	28.0	27.0	32.0	5.5	
100	56	36.0	41.0	53.0	42.5	44.5	43.5	52.0	5.4	48.0	50.0	49.0	57.5	7.4	
	70	37.0	42.0	54.0	43.5	45.5	44.5	53.0	6.5	50.0	52.0	51.0	59.5	9.5	
125	70	60.0	66.0	84.0	68.0	70.0	73.5	86.0	7.3	78.0	80.0	83.0	96.0	10.3	
	90	61.0	67.0	85.0	69.0	71.0	74.5	87.0	9.3	81.0	83.0	86.0	99.0	14.2	
160	90	107.0	122.0	150.0	–	121.0	136.0	148.0	11.5	–	143.0	158.0	170.0	16.5	
	110	108.0	123.0	151.0	–	122.0	137.0	149.0	14.0	–	145.0	160.0	172.0	21.4	
200	110	193.0	222.0	262.0	–	217.0	245.0	259.0	15.4	–	267.0	295.0	309.0	22.9	
	140	196.0	225.0	265.0	–	220.0	248.0	262.0	20.1	–	273.0	301.0	315.0	32.1	

¹⁾ = Weight for CD cylinder

²⁾ = Weight for CS cylinder

© This document, as well as the data, specifications and other information set forth in it, are the exclusive property of Bosch Rexroth AG. It may not be reproduced or given to third parties without its consent. The data specified above only serve to describe the product. No statements concerning a certain condition or suitability for a certain application

can be derived from our information. The information given does not release the user from the obligation of own judgment and verification. It must be remembered that our products are subject to a natural process of wear and aging.