

HYDAC INTERNATIONAL



Electronic Pressure Switch EDS 4100 Programmable ATEX Intrinsically Safe



Description:

The programmable pressure switch EDS 4100 in ATEX version has been specially developed for use in potentially explosive atmospheres and is based on the EDS 4000 series.

The switching point and switch-back point, the function of the switching outputs as N/C or N/O and the switching delay are user-programmable in conjunction with the HYDAC Programming Unit HPG 3000.

As with the industry model, the programmable EDS 4100 in ATEX version has a ceramic measurement cell with thick-film strain gauge for measuring absolute pressure in the low pressure range.

With approval for the following

Protection types and applications:

- I M1 Ex ia I
- II 1G Ex ia IIC T4, T5, T6
- II 1/2G Ex ia IIC T4, T5, T6
- II 2G Ex ia IIC T4, T5, T6
- II 1 D Ex iaD 20 T100 °C

almost all requirements are covered regarding ignition group, error class and temperature class.

Versions for other Protection types and applications are available on request.

Special features:

- Switching point and switch-back point user-programmable
- Accuracy $\leq \pm 1\%$ FS
- Certificates:
DEKRA EXAM BVS 07 ATEX E 041 X
- Very small temperature error
- Excellent EMC characteristics
- Excellent durability

Technical data:

| Input data | |
|------------------------------|---|
| Measuring ranges | 1; 2.5 bar |
| Overload pressures | 3; 8 bar |
| Burst pressures | 5; 12 bar |
| Mechanical connection | G1/4 A DIN 3852 |
| Torque value | 20 Nm |
| Parts in contact with medium | Sensor: Ceramic Mech. connection: 1.4301 Seal: FPM / EPDM |

| Output data | |
|--|--|
| Switch output | 1 x PNP N/C or N/O |
| Output load | during operation: $I_{max} \leq 34$ mA |
| Switching points | user-programmable with HYDAC Programming Unit HPG 3000 |
| Accuracy to DIN 16086, Max. setting | $\leq \pm 0.5\%$ FS typ. |
| Repeatability (at 25 °C) | $\leq \pm 1\%$ FS max. |
| Temperature drift | $\leq \pm 0.1\%$ FS max. |
| Rising switch point and falling switch point delay | $\leq \pm 0.03\%$ FS / °C max. zero point $\leq \pm 0.03\%$ FS / °C max. range |
| Long-term drift | 8 ms to 2000 ms; user-programmable with HYDAC Programming Unit HPG 3000 $\leq \pm 0.3\%$ FS typ. / year |

| Environmental conditions | |
|--|---|
| Storage temperature range | -40 .. +100 °C |
| Fluid temperature range | -20 .. +60 °C / +70 °C / +85 °C |
| CE mark | EN 61000-6-1 / 2 / 3 / 4 EN 60079-0 / 11 / 26 EN 61241-0 / 11 EN 50303 |
| Vibration resistance to DIN EN 60068-2-6 at 10 .. 500 Hz | ≤ 20 g |
| Protection class to IEC 60529 | IP 67 (M12x1, when an IP 67 connector is used) |

Relevant data for Ex applications

| | I M1 II 1G, 1/2G, 2G | II 1 D |
|------------------------------------|---|--------------|
| Supply voltage | 14 .. 28 V DC | |
| Compensated temperature range | T6: -20 .. +60 °C T5, T4: -20 .. +70 °C T100: -20 .. +70 °C | |
| Operating temperature range | T6: -20 .. +60 °C T5, T4: -20 .. +70 °C T100: -20 .. +70 °C | |
| Max. ambient temperature T_a | T6: +60 °C T5, T4: +70 °C | T100: +70 °C |
| Max. input current | 100 mA | 93 mA |
| Max. input power | 0.7 W | 0.65 W |
| Max. internal capacitance | 33 nF | 33 nF |
| Max. internal inductance | 0 mH | 0 mH |
| Insulation voltage ¹⁾ | 50 V AC, with integrated overvoltage protection EN 61000-6-2 | |
| Approved intrinsic safety barriers | Pepperl & Fuchs: Z 787 Telematic Ex STOCK: MTL 7087 | |

| Other data | |
|-----------------------------------|--------------------------------------|
| Residual ripple of supply voltage | $\leq 5\%$ |
| Life expectancy | > 10 million cycles 0 .. 100 % FS |
| Weight | ~ 150 g |

Note: Reverse polarity protection of the supply voltage, excess voltage, override and short circuit protection are provided. FS (Full Scale) = relative to complete measuring range
¹⁾ 500 V AC on request

Setting options:

In conjunction with the HYDAC Programming Unit HPG 3000, all the settings are combined in an easy-to-follow menu.

Setting ranges for the switch outputs:

| Measuring range in bar | Increment in bar |
|------------------------|------------------|
| 0 .. 1 | 0.002 |
| 0 .. 2.5 | 0.005 |

The switch point (upper switch value) on all instruments is between 5 % and 100 % of the measuring range and the switch-back point (lower switch value) is between 1 % and 96 % of the measuring range.

| | Minimum value in ms | Maximum value in ms |
|-------------------------------|---------------------|---------------------|
| Switch-on delay Ton1/Ton2 | 8 | 2040 |
| Switch-off delay ToF1/ToF2 | 8 | 2040 |

The increment for all instruments is 8 ms.

Pin connections:

M12x1, 5 pole

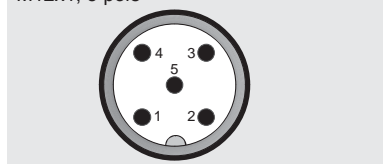

| Pin | Process connection | HPG connection |
|-----|--------------------|-----------------|
| 1 | +U _b | +U _b |
| 2 | 0 V | Comport 1 * |
| 3 | 0 V | 0 V |
| 4 | Out 1 | n.c. |
| 5 | 0 V | Comport 2 * |

* Comport = programming connection

Areas of application:

| Code No. for use in Model code | 1 | 2 | 3 | 8 |
|--------------------------------|---|--|---|--|
| Protection Type | I M1 Ex ia I | II 1G Ex ia IIC T4, T5, T6 | II 2G Ex ia IIC II 1/2G Ex ia IIC T4, T5, T6 | II 1D Ex iaD 20 T100 °C |
| Certificate | DEKRA EXAM BVS 07 ATEX E 041 X | DEKRA EXAM BVS 07 ATEX E 041 X | DEKRA EXAM BVS 07 ATEX E 041 X | DEKRA EXAM BVS 07 ATEX E 041 X |
| Zones / Categories | Group I Category M1 Mining Protection class: intrinsically safe ia with barrier | Group II Category 1G Gases Protection class: intrinsically safe ia with barrier For use in Zone 0 T4, T5: T _a = 70 °C T6: T _a = 60 °C | Group II Category 2G, 1/2G Gases Protection class: intrinsically safe ia with barrier For use in Zone 1, 2 For mounting to Zone 0 T4, T5: T _a = 70 °C T6: T _a = 60 °C | Group II Category iD Dusts Protection class: intrinsically safe ia with barrier For use in Zone 20, 21, 22 For mounting to Zone 20 T100: T _a = 70 °C |
| Electrical Connection | 8 | 8 | 8 | 8 |

Instruments for other Protection types and applications are available on request. Please contact our technical sales department for more information.

Model code:

EDS 4 1 4 8 - XXXX - P - A N X - 000 - X 1

Mechanical connection

4 = G1/4 A DIN 3852 (male)

Electrical connection

8 = Male M12x1, 5 pole
(connector not supplied)

Pressure ranges in bar

01.0; 02.5

Switching output

P = Programmable

Approval

A = ATEX

Insulation voltage

N = 50 V AC

Protection types and applications (code)

1 = I M1 Ex ia I
2 = II 1G Ex ia IIC T4, T5, T6
3 = II 2G Ex ia IIC T4, T5, T6 / II 1/2G Ex ia IIC T4, T5, T6
8 = II 1D Ex iaD 20 T100 °C

Modification number

000 = Standard

Seal material (in contact with fluid)

F = FPM seal (e.g.: for hydraulic oils)

E = EPDM seal (e.g.: for refrigerants)

Material of connection (in contact with fluid)

1 = Stainless steel

Accessories:

Appropriate accessories, such as electrical connectors, can be found in the Accessories brochure.

Safety instructions:

- These units must only be programmed outside the potentially explosive location.
- When operating in potentially explosive locations, the programming cables may only be connected to the 0 V outside of the potentially explosive area.
- The switching output draws the switching energy from the power supply to the pressure switch. No additional energy is introduced into the electrical circuit through the switching output.
- Dual Zener barriers specified and approved in the technical data must be used to connect the pressure switch. These have a reverse polarity diode to decouple the signal. The signal path may only be passively loaded.
- Ensure that measured fluids in contact with the pressure switch are compatible with the materials used.

Note:

The information in this brochure relates to the operating conditions and applications described. For applications or operating conditions not described, please contact the relevant technical department. Subject to technical modifications.

Dimensions:

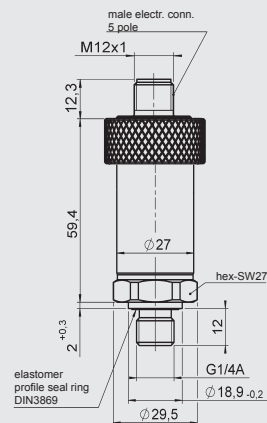

Programming Unit:

(must be ordered separately)

HPG 3000 – 000
Portable Programming Unit
Part. No. 909 422

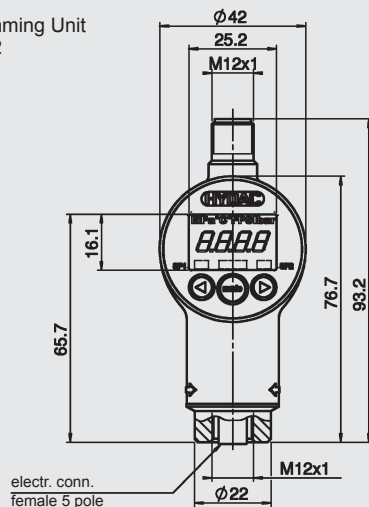

Caution:

The HPG 3000 Programming Unit may only be used outside the potentially explosive area.