

SINGLE ACTING METRIC RANGE

Hydraulic equipment for all uses

◀ CONTENTS ▶

Page		Ram Style No.		
		Female Rod	Male Rod	Pin Hole
2	General specifications			
3	Part Numbering System			
4	Basic Dimensions			
5	Buckling Calculations			
6	Buckling Force/Length Graphs			
7	Load Calculations			
8	PBV Flow Chart			
9	Pin Mounted Rams	SAM0	SAM0M	SAM1
10	Pin Mounted Rams With Damping	SAM2	SAM2M	SAM3
11	Bushed Pin Mounted Rams	SAM16	SAM16M	SAM17
12	" " with Damping	SAM18	SAM18M	SAM19
13	Spherical Eye Mounted Rams	SAM32	SAM32M	SAM33
14	Spherical Eye Mounted Rams With Damping	SAM34	SAM34M	SAM35
15	Front Flange Mounted Rams	SAM48	SAM48M	SAM49
16	Rear Flange Mounted Rams	SAM64	SAM64M	SAM65
17	Trunnion Mounted Rams	SAM96	SAM96M	SAM97
18	Pin Mounted with PBV	SAM4	SAM4M	SAM5
19	" " with Damping & PBV	SAM6	SAM6M	SAM7
20	Bushed Pin Mounted with PBV	SAM20	SAM20M	SAM21
21	" " with Damping & PBV	SAM22	SAM22M	SAM23
22	Spherical Eye Mounted Ram with PBV	SAM36	SAM36M	SAM37
23	" " with Damping & PBV	SAM38	SAM38M	SAM39
24	Front Flange Mounted Ram with PBV	SAM52	SAM52M	SAM53
25	Rear Flange Mounted Ram with PBV	SAM68	SAM68M	SAM69
26	Trunnion Mounted Ram with PBV	SAM100	SAM100M	SAM101
27	Trunnion Mounting Blocks			
28	Clevis Eyes : Plain & Bushed			
29	Spherical Eyes			
30	Spares, Installation and Maintenance			

SINGLE ACTING METRIC RANGE

Hydraulic equipment for all uses

◀ GENERAL SPECIFICATIONS ▶

This catalogue covers our range of Standard Single Acting Metric rams. These rams utilise a welded construction and are ideal for heavy industrial use. Combined with our company policy of 100% product testing and years of experience, we produce a comparatively low cost product on short lead times with no compromise on quality. This catalogue covers only a small part of the wide range of rams that we produce, if you require a product not listed, or to a modified specification please contact the sales office who will be happy to advise you.

Options available on request include:-

Stainless steel piston rods, marine specification, telescopic, spring return, low friction and chemically resistant seals, limit switches, position transducers and two pack epoxy paint finish.

Maximum pressure rating (see note 1)	207 Bar (3000 PSI)
Test pressure	310 Bar (4500 PSI)
Maximum rod velocity	0.5 m/s
Fluid temperature range	-10 to +90 degrees C
Ambient temperature range	-10 to +90 degrees C
Filtration requirement	25 micron abs, (recommended min.)
Fluid specification	Mineral Oil DIN51524+51525 HL, H-LP & HV ISO HM (see note 2)
Fluid viscosity	5 to 200 cSt
Rod finish	20 micron hard chromium plate min Ra.=0.4

NOTE 1 ▶

Maximum pressure rating should not be exceeded, allowance must be made for pulsation and pressure peaks. The customer must ensure that damping pressures do not exceed the maximum pressure rating.

NOTE 2 ▶

For use with other fluids please contact our sales office. To ensure that testing is carried out with the correct grade of fluid and that all materials are compatible, please state the fluid type when making an order. If no fluid type is specified mineral oil will be assumed.

The information contained in the publication is for guidance only . We reserve the right to make changes without notice. The responsibility for checking calculations, formulae, graphs and tables lies with the customer. The vendor will accept no responsibility for any loss or accident howsoever caused.

Certified drawings are available on request.

SINGLE ACTING METRIC RANGE

Hydraulic equipment for all uses

◀ PART NUMBERING SYSTEM ▶

How our part numbering system works:

example: **100-70-SAM0-0250**

BORE & ROD DIAMETER in mm

25 - 19 = 25mm bore, 19mm rod
 32 - 25 = 32mm bore, 25mm rod
 40 - 28 = 40mm bore, 28mm rod
 50 - 40 = 50mm bore, 40mm rod
 63 - 40 = 63mm bore, 40mm rod
 80 - 50 = 80mm bore, 50mm rod
 100 - 70 = 100mm bore, 70mm rod
 125 - 90 = 125mm bore, 90mm rod

STROKE in mm
 Refer to data sheets and buckling calculations for maximum values.

Single Acting Metric ram style

	WITHOUT PBV			WITH PBV		
Type of Mounting	Male Rod End	Female Rod End	Pinhole In Rod End	Male Rod End	Female Rod End	Pinhole In Rod End
Pin Mounted	SAM0M	SAM0	SAM1	SAM4M	SAM4	SAM5
Pin Mounted with Damping	SAM2M	SAM2	SAM3	SAM6M	SAM6	SAM7
Bushed	SAM16M	SAM16	SAM17	SAM20M	SAM20	SAM21
Bushed with Damping	SAM18M	SAM18	SAM19	SAM22M	SAM22	SAM23
Spherical Eye	SAM32M	SAM32	SAM33	SAM36M	SAM36	SAM37
Spherical Eye with Damping	SAM34M	SAM34	SAM35	SAM38M	SAM38	SAM39
Front Flange	SAM48M	SAM48	SAM49	SAM52M	SAM52	SAM53
Rear Flange	SAM64M	SAM64	SAM65	SAM68M	SAM68	SAM69
Trunnion	SAM96M	SAM96	SAM97	SAM100M	SAM100	SAM101

SINGLE ACTING METRIC RANGE

Hydraulic equipment for all uses

◀ BASIC DIMENSIONS ▶

The dimensions on this page are common to all the following single acting rams.

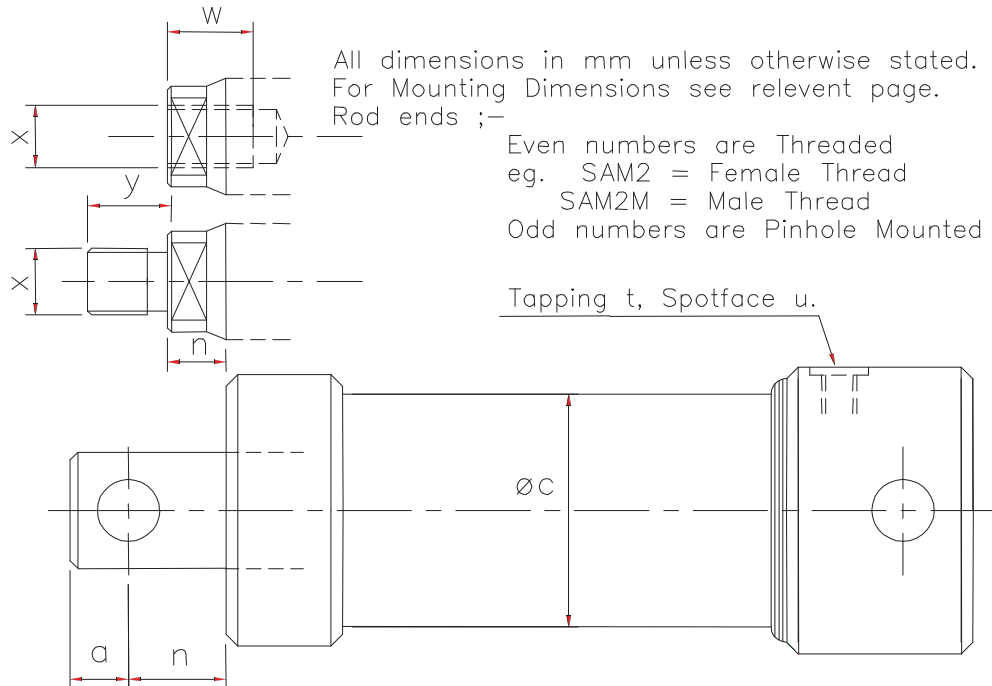

Type No.	Bore Ø	Rod Ø	Thrust Area cm ²	Pull Area cm ²	a	c Ø	n Pin	n Thrd	t BSP *	u	w	y	x
25-19-SAM_	25	19	5.0	2.1	10	38	13	10	1/4"	22	25	25	M10x1.50
32-25-SAM_	32	25	8.0	3.1	11	39	14	12	1/4"	22	25	30	M12x1.75
40-28-SAM_	40	28	12.6	6.4	14	50	17	14	3/8"	25	30	42	M16x2.00
50-40-SAM_	50	40	19.6	7.1	18	60	22.5	15.5	3/8"	25	40	48	M20x1.50
63-40-SAM_	63	40	31.2	18.6	18	73	28	16	3/8"	25	45	58	M24x2.00
80-50-SAM_	80	50	50.2	30.6	25	95	33	18	3/8"	25	55	68	M30x2.00
100-70-SAM_	100	70	78.5	40.0	35	115	45	22	1/2"	30	75	80	M39x3.00
125-90-SAM_	125	90	122.7	59.1	40	145	60	24	1/2"	30	90	86	M45x3.00

25 & 32 bore rams complete with PBV have 3/8" ports

SINGLE ACTING METRIC RANGE

Hydraulic equipment for all uses

BUCKLING CALCULATIONS

The safe working load may be determined from the formula:

The safe Working Load = Buckling Force x c / FoS

Where:- c is a constant determined from the table below.

FoS is the required Factor of Safety, we recommend a minimum of 3. Where shock loads are present this should be doubled.

The actual force to cause buckling may be determined from the following graphs. Note the solid curves are for rear mountings (SAM0, SAM1, SAM2, SAM3, SAM16, SAM17, SAM32, SAM33, SAM64, SAM65) and the dashed curves are for front flange or front trunnion mounted rams (SAM48, SAM49, SAM96 & SAM97).

The extended length refers to the distance between the mounting points of the ram, effectively the extended rod length for front end mounted rams.

Both ends rounded
e.g. Pin or Trunnion
mounted



One end fixed, one end
rounded e.g. Flange
mounted c/w spherical eye



One end fixed, one end
free e.g. Flange or Foot
mounted

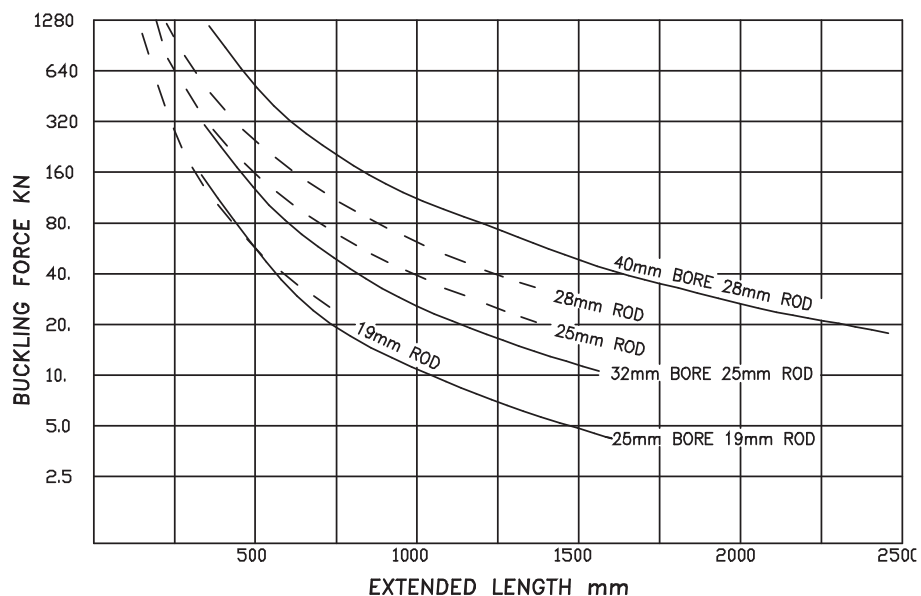
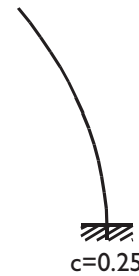

SINGLE ACTING METRIC RANGE

Hydraulic equipment for all uses

BUCKLING FORCE / LENGTH GRAPHS

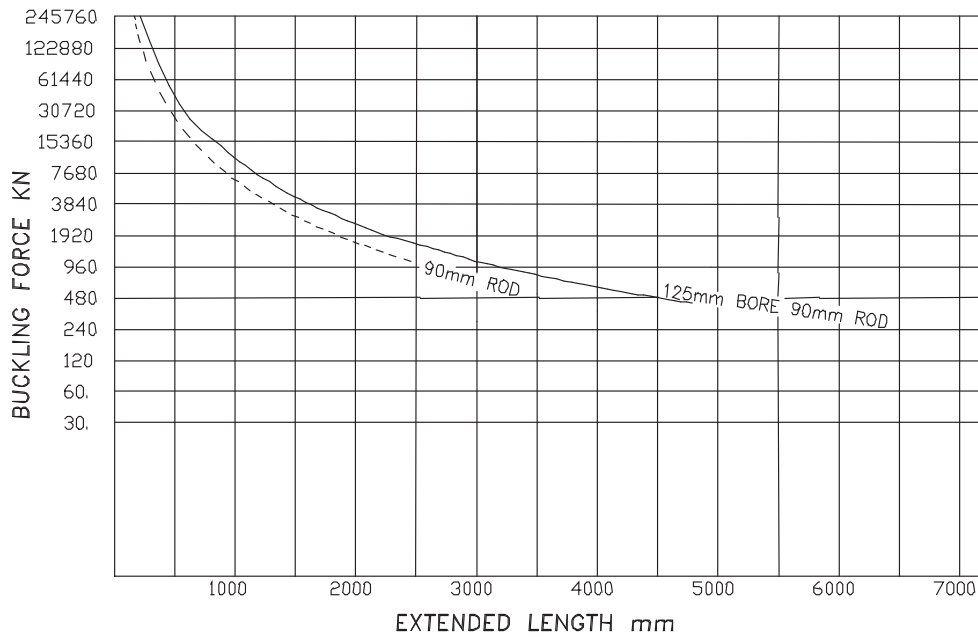
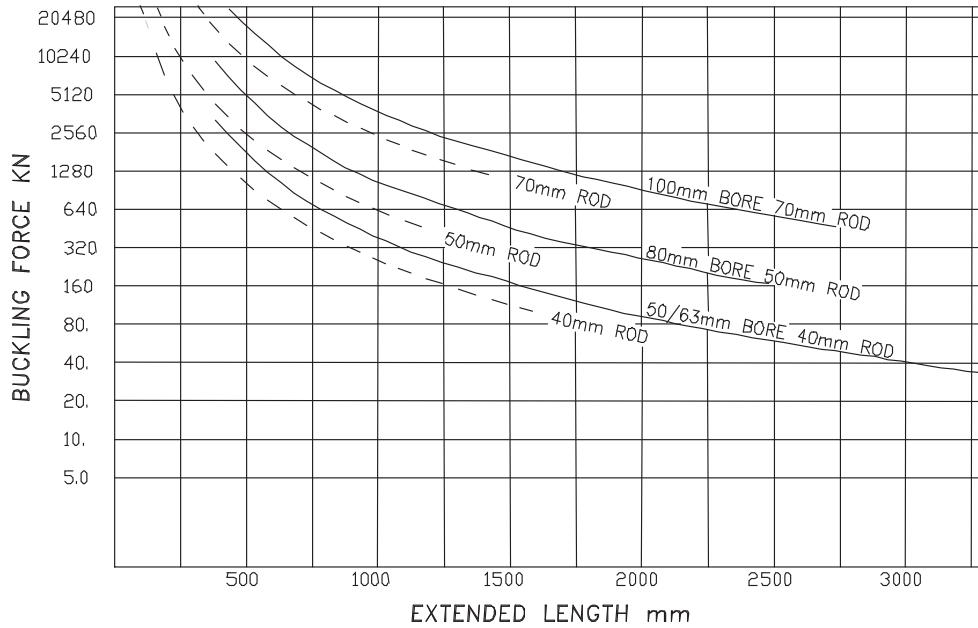

SINGLE ACTING METRIC RANGE

Hydraulic equipment for all uses

◀ LOAD CALCULATIONS ▶

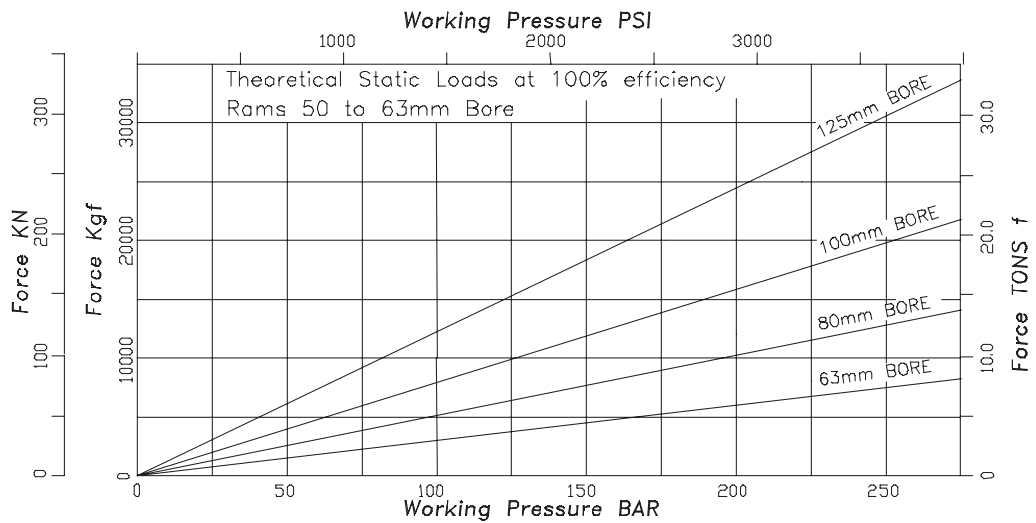
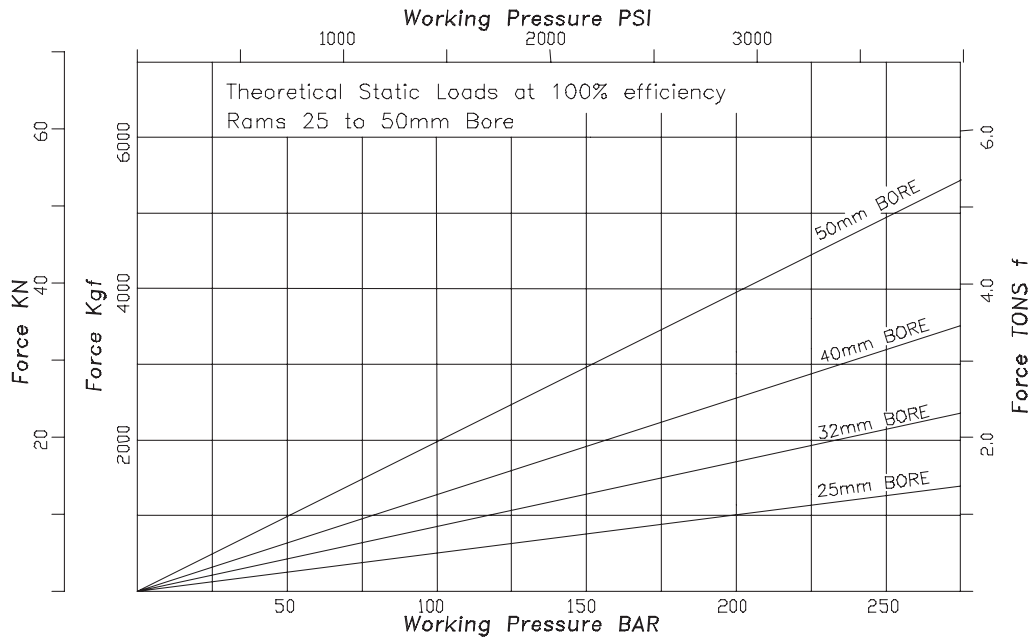

SINGLE ACTING METRIC RANGE

Hydraulic equipment for all uses

◀ PIPE BREAK VALVE (PBV) FLOW CHART ▶

Pipe Break Valves may be installed as a safety device. They may be considered as a flow fuse when oil flow leaving the hydraulic ram exceeds the present flow rate of the valve, such as when a hose has failed the valve automatically closes, stopping oil flow out of the ram, and hence preventing any further descent in the ram. In order to release the valve, oil pressure must be applied to the connection port.

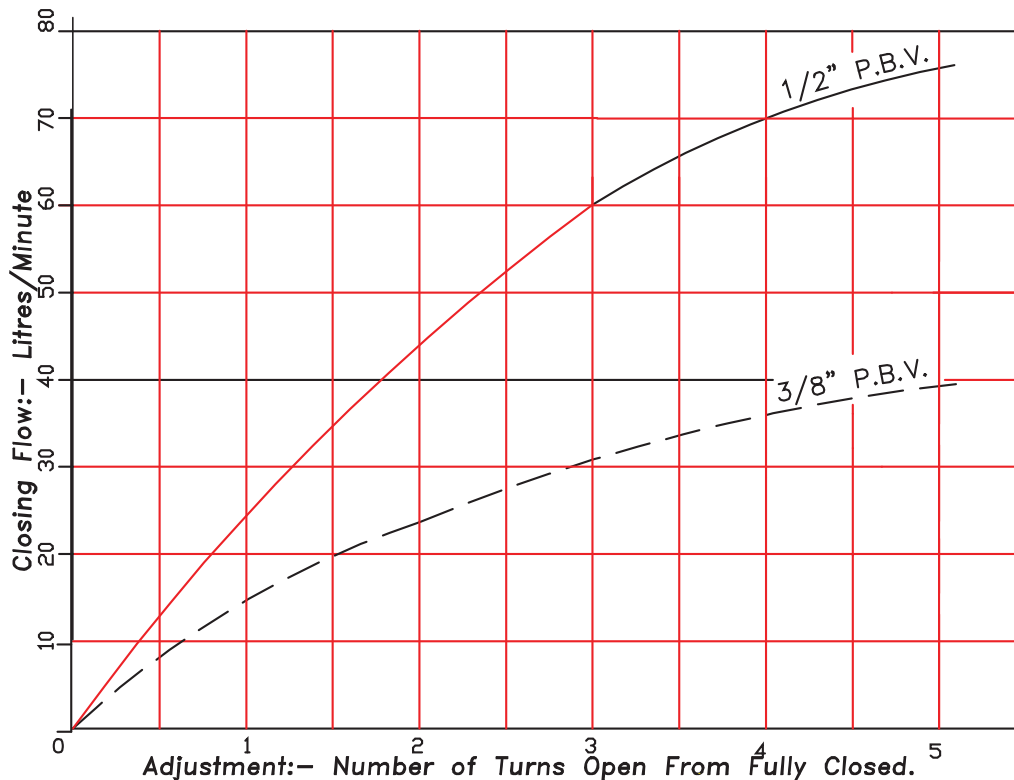

Corresponding test conditions:-

- Oil type = Shell Tellus 37
- Oil viscosity = 76cSt (10°E)
- Ambient temperature = 25°C

Note: 25 & 32mm bore rams which are normally supplied with 1/4" BSP ports are fitted with 3/8" BSP ports when supplied with integral PBV.

SINGLE ACTING METRIC RANGE

Hydraulic equipment for all uses

◀ PIN MOUNTED RAMS ▶

Note: If rams are required for angular movements, bushes or spherical end bearings should be considered.

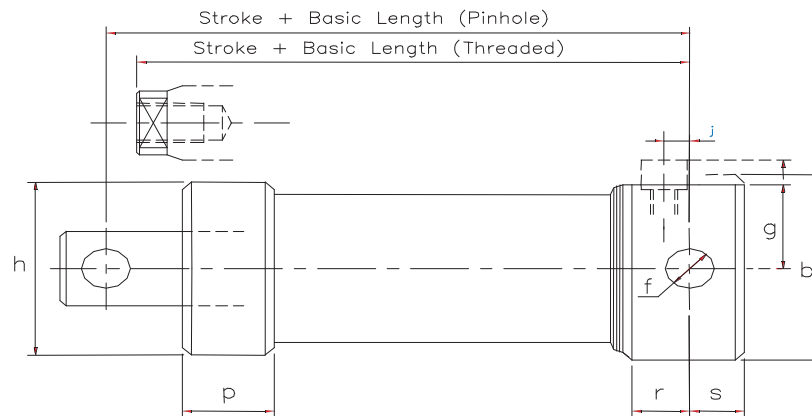

All Dimensions in mm.

Type No.	b Ø	f Ø	g	h Ø	j	p	r	s	Basic Length (Pin.)	Basic Length (Thr.)	Stroke Range
25-19-SAM 0/1	38	10.5	29	44.5	13	26	27	10	98 148	95 145	10-400 401-800
32-25-SAM 0/1	45	12.5	20	45	13	25	26	11	97 137	95 135	10-350 351-725
40-28-SAM 0/1	55	17.5	25	55	15	25	30	14	100 150 200	97 147 197	10-457 458-850 851-1350
50-40-SAM 0/1	70	20.5	32	70	0	35	15	18	115 165 215	108 158 208	10-500 501-1000 1001-1500
63-40-SAM 0/1	80	25.4	40	85	0	30	14	18	120 170 220	108 158 208	10-610 611-1000 1001-1500
80-50-SAM 0/1	100	30.5	48	100	4	40	22	25	155 205 255	140 190 240	10-600 601-1100 1101-1600
100-70-SAM 0/1	130	40.5	62	130	11	52	30	35	185 235 285	162 212 262	10-650 651-1150 1151-1650
125-90-SAM 0/1	150	50.5	72	150	15	50	35	43	233 313 393	197 277 357	10-750 751-1500 1501-2200

SINGLE ACTING METRIC RANGE

Hydraulic equipment for all uses

◀ PIN MOUNTED RAMS with DAMPING ▶

Note: Damping must be adjusted to ensure excessive impulse pressures are not induced.

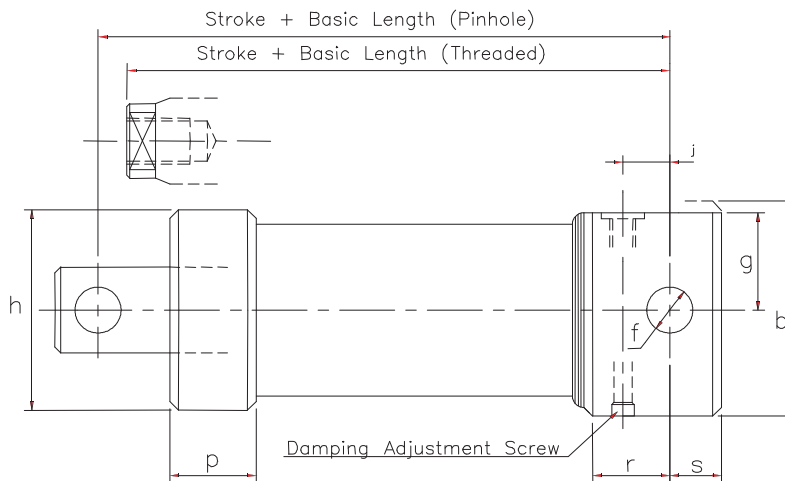

All Dimensions in mm.

Type No.	b Ø	f Ø	g	h Ø	j	p	r	s	Damping Length	Basic Length (Pin.)	Basic Length (Thr.)	Stroke Range
25-19-SAM 2/3	45	10.5	20.5	44.5	15	26	29	10	15	121 171	118 168	10-400 401-800
32-25-SAM 2/3	45	12.5	20	45	16	25	28	11	15	122 162	120 160	10-350 351-725
40-28-SAM 2/3	55	17.5	25	55	20	25	33	14	25	113 163 213	110 160 210	10-457 458-850 851-1350
50-40-SAM 2/3	70	20.5	32	70	23	35	36	18	25	145 195 245	138 188 238	10-500 501-1000 1001-1500
63-40-SAM 2/3	80	25.4	40	85	28	30	44	18	25	158 208 258	146 196 246	10-610 611-1000 1001-1500
80-50-SAM 2/3	95	30.5	48	100	30	40	45	25	25	181 231 281	166 216 266	10-600 601-1100 1101-1600
100-70-SAM 2/3	115	40.5	57.5	130	40	52	57	35	25	224 274 324	201 251 301	10-650 651-1150 1151-1650
125-90-SAM 2/3	150	50.5	75	150	45	50	64	43	25	298 378 458	262 342 422	10-750 751-1500 1501-2200

SINGLE ACTING METRIC RANGE

Hydraulic equipment for all uses

◀ BUSHED PIN MOUNTED RAMS ▶

Bushed pin hole to suit f7 tolerance pins.

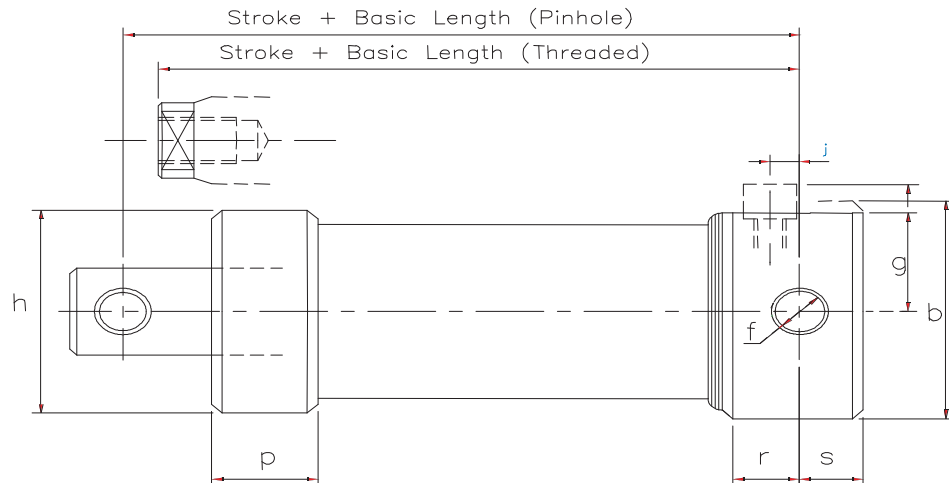

All Dimensions in mm.

Type No.	b Ø	f Ø	g	h Ø	j	p	r	s	Basic Length (Pin.)	Basic Length (Thr.)	Stroke Range
25-19-SAM 16/17	38	10	29	44.5	13	26	27	10	98 148	95 145	10-400 401-800
32-25-SAM 16/17	45	12	20	45	13	25	26	11	97 137	95 135	10-350 351-725
40-28-SAM 16/17	55	17	25	55	15	25	30	14	100 150 200	97 147 197	10-457 458-850 851-1350
50-40-SAM 16/17	70	20	32	70	0	35	15	18	115 165 215	108 158 208	10-500 501-1000 1001-1500
63-40-SAM 16/17	80	25	40	85	0	30	17	18	120 170 220	108 158 208	10-610 611-1000 1001-1500
80-50-SAM 16/17	100	30	48	100	4	40	22	25	155 205 255	140 190 240	10-600 601-1100 1101-1600
100-70-SAM 16/17	130	40	62	130	11	52	30	35	185 235 285	162 212 262	10-650 651-1150 1151-1650
125-90-SAM 16/17	150	50	75	150	15	50	35	43	233 313 393	197 277 357	10-750 751-1500 1501-2200

SINGLE ACTING METRIC RANGE

Hydraulic equipment for all uses

◀ BUSHED PIN MOUNTED RAMS with DAMPING ▶

Bushed pin holes to suit f7 toleranced pins.

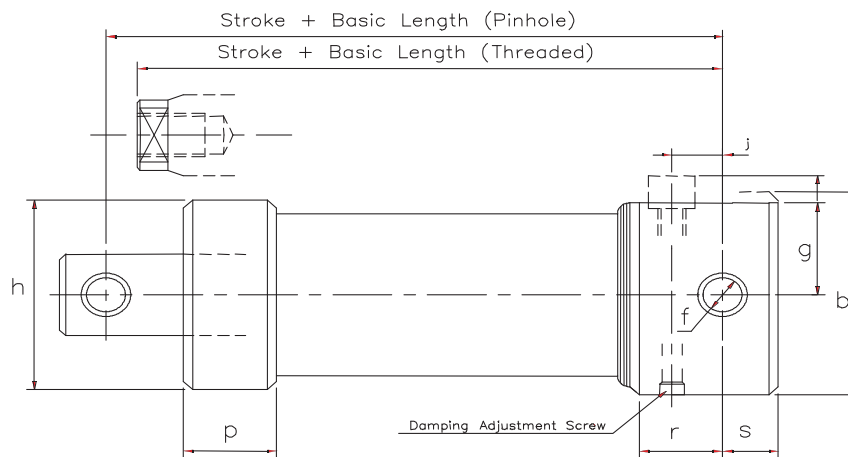

All Dimensions in mm.

Type No.	b Ø	f Ø	g	h Ø	j	p	r	s	Damping Length	Basic Length (Pin.)	Basic Length (Thr.)	Stroke Range
25-19-SAM 18/19	45	10	20.5	44.5	15	26	29	10	15	121 171	118 168	10-400 401-800
32-25-SAM 18/19	45	12	20	45	16	25	28	11	15	122 162	120 160	10-350 351-725
40-28-SAM 18/19	55	17	25	55	20	25	33	14	25	113 163 213	110 160 210	10-457 458-850 851-1350
50-40-SAM 18/19	70	20	32	70	23	35	36	18	25	145 195 245	138 188 238	10-500 501-1000 1001-1500
63-40-SAM 18/19	80	25	40	85	28	30	44	18	25	158 208 258	146 196 246	10-610 611-1000 1001-1500
80-50-SAM 18/19	95	30	48	100	30	40	45	25	25	181 266 351	166 251 336	10-600 601-1100 1101-1601
100-70-SAM 18/19	115	40	57.5	130	40	52	57	35	25	224 274 324	201 251 301	10-650 651-1150 1151-1650
125-90-SAM 18/19	150	50	75	150	45	50	64	43	25	293 378 458	262 342 422	10-750 751-1500 1501-2200

SINGLE ACTING METRIC RANGE

Hydraulic equipment for all uses

◀ SPHERICAL EYE MOUNTED RAMS ▶



All Dimensions in mm.

Type No.	b Ø	f Ø	g	h Ø	j	p	q	x	z	Basic Length (Pin.)	Basic Length (Thr.)	Stroke Range
25-19-SAM 32/33	38	10	29	44.5	39	26	15	9	24	124 274	121 171	10-400 401-800
32-25-SAM 32/33	45	12	20	45	43	25	17	10	27	125 165	123 163	10-350 351-725
40-28-SAM 32/33	55	17	25	55	53	25	23	14	35	133 183 233	130 180 230	10-457 458-850 851-1350
50-40-SAM 32/33	70	20	28	70	54	35	26.5	16	38	168 218 268	161 211 261	10-500 501-1000 1001-1500
63-40-SAM 32/33	75	25	37.5	85	63	30	32	20	45	183 233 283	171 221 271	10-610 611-1000 1001-1500
80-50-SAM 32/33	95	30	48	100	72	40	36.5	22	51	219 269 319	204 254 304	10-600 601-1100 1101-1600
100-70-SAM 32/33	115	40	57.5	130	94	52	46	28	69	267 317 367	244 294 344	10-650 651-1150 1151-1650
125-90-SAM 32/33	150	50	72	150	106	50	56	35	88	325 405 485	289 369 449	10-750 751-1500 1501-2200

SINGLE ACTING METRIC RANGE

Hydraulic equipment for all uses

◀ SPHERICAL EYE MOUNTED RAMS with DAMPING ▶

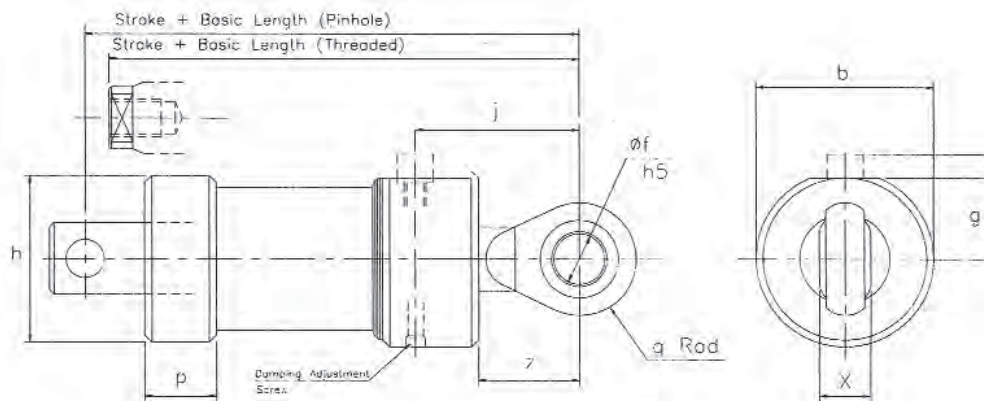

All Dimensions in mm.

Type No.	b Ø	f Ø	g	h Ø	j	p	q	x	z	Damped Length	Basic Length (Pin.)	Basic Length (Thr.)	Stroke Range
25-19-SAM 34/35	38	10	29	44.5	39	26	15	9	24	15	144 194	141 191	10-400 401-800
32-25-SAM 34/35	45	12	20	45	43	25	17	10	27	15	149 189	147 197	10-350 351-725
40-28-SAM 34/35	55	17	25	55	53	25	23	14	35	25	147 197 247	144 194 244	10-457 458-850 851-1350
50-40-SAM 34/35	70	20	28	70	54	35	26.5	16	38	25	186 236 286	179 229 279	10-500 501-1000 1001-1500
63-40-SAM 34/35	76	25	37.5	85	65	30	32	20	45	25	197 247 297	185 235 285	10-610 611-1000 1001-1500
80-50-SAM 34/35	95	30	48	100	72	40	36.5	22	51	25	219 269 319	204 254 304	10-600 601-1100 1101-1600
100-70-SAM 34/35	115	40	57.5	130	89	52	46	28	69	25	268 318 368	245 295 345	10-650 651-1150 1151-1650
125-90-SAM 34/35	150	50	75	150	110	50	56	35	88	25	360 440 520	324 404 484	10-750 751-1500 1501-2200

SINGLE ACTING METRIC RANGE

Hydraulic equipment for all uses

◀ FRONT FLANGE MOUNTED RAMS ▶

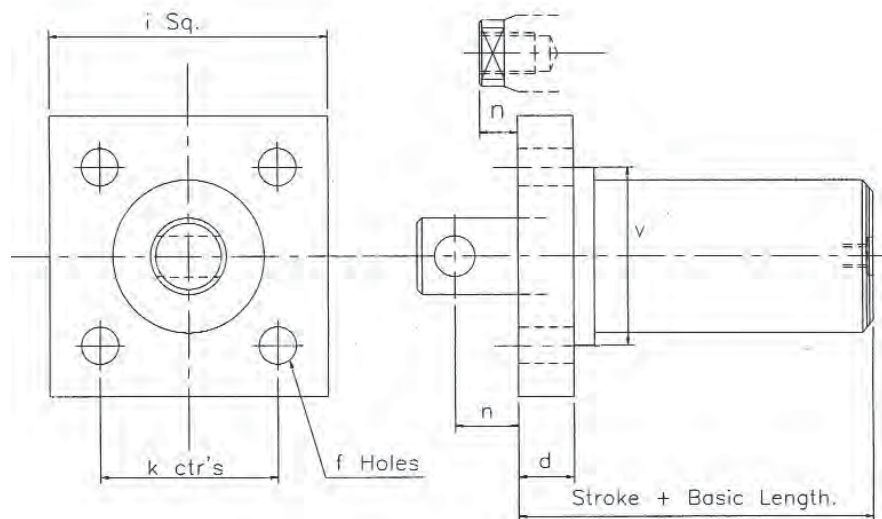

Type No.	d	f Ø	i	k	n (Pin.)	n (Thr.)	v Ø	Basic Length	Stroke Range
25-19-SAM 48/49	10	6.35	60	45	13	10	47	80 130	10-400 401-800
32-25-SAM 48/49	18	9	70	50	14	12	50	96 136	10-350 351-725
40-28-SAM 48/49	20	8.5	80	60	17	14	60	87 137 187	10-457 458-850 851-1350
50-40-SAM 48/49	23	10.5	90	65	22	15	72	101 151 201	10-500 501-1000 1001-1500
63-40-SAM 48/49	23	12.5	114	80	28	16	82	97 147 197	10-610 611-1000 1001-1500
80-50-SAM 48/49	23	16.5	130	100	33	18	110	121 171 221	10-400 401-750 751-1100
100-70-SAM 48/49	28	21	160	120	45	22	130	142 192 242	10-650 651-1150 1151-1650
125-90-SAM 48/49	35	25	200	150	60	24	160	166 246 326	10-1000 1001-1600 1601-2200

SINGLE ACTING METRIC RANGE

Hydraulic equipment for all uses

◀ REAR FLANGE MOUNTED RAMS ▶

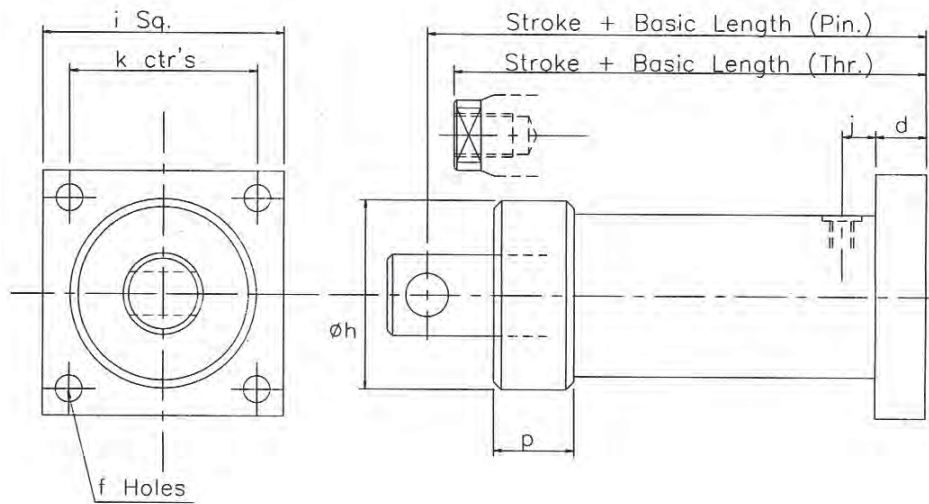

All Dimensions in mm.

Type No.	d	f Ø	h Ø	i	j	k	p	Basic Length (Pin.)	Basic Length (Thr.)	Stroke Range
25-19-SAM 64/65	10	6.35	44.5	60	19	45	26	99 149	96 146	10-400 401-800
32-25-SAM 64/65	18	9	45	70	20	50	25	122 162	120 160	10-350 351-725
40-28-SAM 64/65	20	8.5	55	80	21	60	25	126 176 226	123 173 223	10-457 458-850 851-1350
50-40-SAM 64/65	23	10.5	70	90	21	65	35	159 209 259	145 195 245	10-500 501-1000 1001-1500
63-40-SAM 64/65	23	12.5	85	114	22	80	30	165 215 265	153 203 253	10-610 611-1000 1001-1500
80-50-SAM 64/65	23	16.5	100	130	21	100	40	193 243 293	178 228 278	10-600 601-1100 1101-1600
100-70-SAM 64/65	28	21	130	160	25	120	52	226 276 326	203 253 303	10-650 651-1150 1151-1650
125-90-SAM 64/65	35	25	150	200	28	150	50	276 356 436	240 320 400	10-750 751-1500 1501-2200

SINGLE ACTING METRIC RANGE

Hydraulic equipment for all uses

◀ TRUNNION MOUNTED RAM ▶

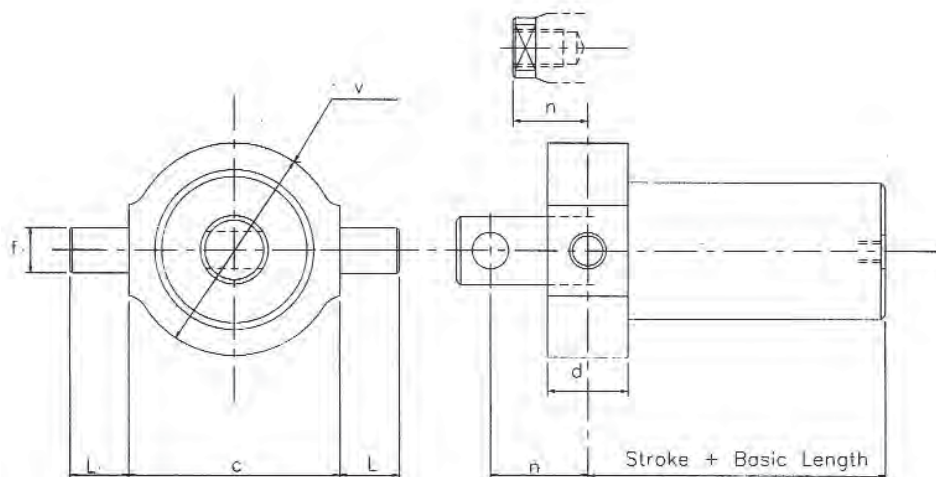

All Dimensions in mm.

Type No.	c	d	f Ø	L	n (Pin.)	n (Thr.)	v	Basic Length	Stroke Range
25-19-SAM 96/97	50	30	10	16	28	26	50	73 123	10-400 401-800
32-25-SAM 96/97	55	38	12	18	33	31	55	77 117	10-350 351-725
40-28-SAM 96/97	65	34	17	20	34	31	65	71 121 171	10-457 458-850 851-1350
50-40-SAM 96/97	80	48	20	25	46	39	80	92 142 192	10-500 501-1000 1001-1500
63-40-SAM 96/97	100	34	25	35	45	33	95	80 130 180	10-610 611-1000 1001-1500
80-50-SAM 96/97	120	38	30	45	52	37	120	102 152 202	10-400 401-750 751-1100
100-70-SAM 96/97	140	52	40	50	71	48	140	116 166 216	10-650 651-1150 1151-1650
125-90-SAM 96/97	180	66	50	60	93	57	180	133 213 293	10-1000 1001-1600 1601-2200

SINGLE ACTING METRIC RANGE

Hydraulic equipment for all uses

◀ PIN MOUNTED RAMS with PBV ▶

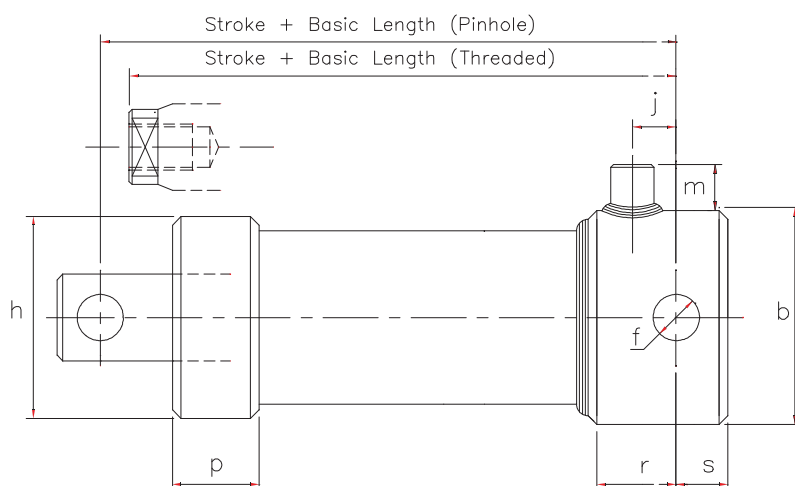

All Dimensions in mm.

Type No.	b	f	h	j	m	p	r	s	Basic Length (Pin.)	Basic Length (Thr.)	Stroke Range
25-19-SAM 4/5	38	10.5	44.5	19	20	26	30	10	101 151	98 148	10-400 401-800
32-25-SAM 4/5	45	12.5	45	22	15	25	35	11	107 147	105 145	10-350 351-725
40-28-SAM 4/5	55	17.5	55	17	29	25	31	14	100 150 200	97 147 197	10-457 458-850 851-1350
50-40-SAM 4/5	70	20.5	70	20	24	35	38	18	135 185 235	128 178 228	10-500 501-1000 1001-1500
63-40-SAM 4/5	80	25.4	85	14	27	30	30	18	137 187 237	125 175 225	10-610 611-1000 1001-1500
80-50-SAM 4/5	100	30.5	100	4	22	40	22	25	155 205 255	140 190 240	10-600 601-1100 1101-1600
100-70-SAM 4/5	130	40.5	130	8	28	52	27	35	185 235 285	162 212 262	10-650 651-1150 1151-1650
125-90-SAM 4/5	150	50.5	150	15	26	50	37	43	233 313 393	197 277 357	10-750 751-1500 1501-2200

SINGLE ACTING METRIC RANGE

Hydraulic equipment for all uses

◀ PIN MOUNTED RAMS with DAMPING & PBV ▶

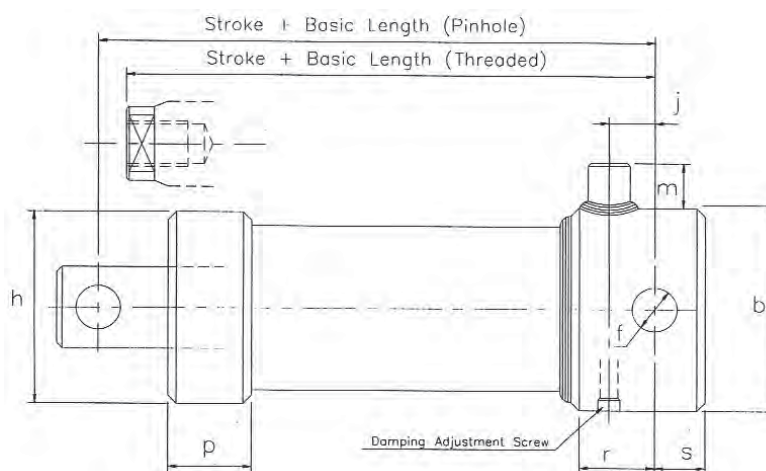

All Dimensions in mm.

Type No.	b	f Ø	h Ø	j	m	p	r	s	Basic Length (Pin.)	Basic Length (Thr.)	Stroke Range
25-19-SAM 6/7	45	10.5	44.5	19	28	26	34	10	128 178	125 175	10-400 401-800
32-25-SAM 6/7	45	12.5	45	22	28	25	37	11	132 172	130 170	10-350 351-725
40-28-SAM 6/7	55	17.5	55	24	28	25	38	14	121 171 221	118 168 218	10-457 458-850 851-1350
50-40-SAM 6/7	70	20.5	70	20	24	35	38	18	145 195 245	138 188 238	10-500 501-1000 1001-1500
63-40-SAM 6/7	80	25.4	85	28	16	30	44	18	158 208 258	146 196 246	10-610 611-1000 1001-1500
80-50-SAM 6/7	100	30.5	100	30	15	40	47	25	181 231 281	166 216 266	10-600 601-1100 1101-1600
100-70-SAM 6/7	130	40.5	130	36	12	52	56	35	220 270 320	197 247 297	10-650 651-1150 1151-1650
125-90-SAM 6/7	150	50.5	150	46	13	50	56	43	298 378 458	262 342 422	10-750 751-1500 1501-2200

SINGLE ACTING METRIC RANGE

Hydraulic equipment for all uses

◀ BUSHED PIN MOUNTED RAMS with PBV ▶

Bushed pin holes to suit f7 tolerance pins.

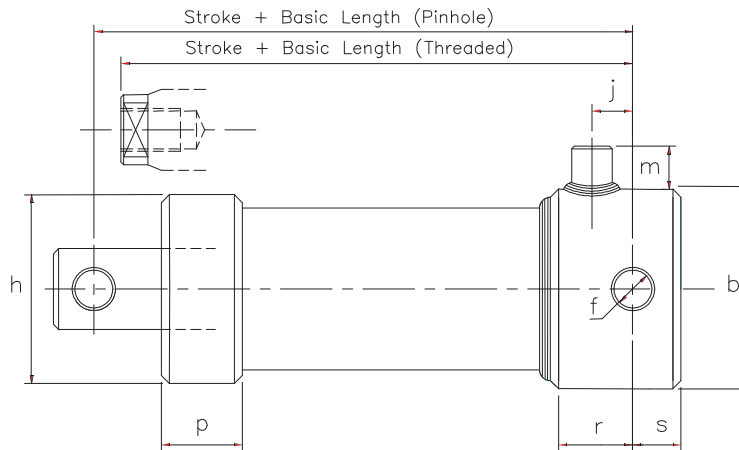

All Dimensions in mm.

Type No.	b	f Ø	h Ø	j	m	p	r	s	Basic Length (Pin.)	Basic Length (Thr.)	Stroke Range
25-19-SAM 20/21	38	10	44.5	19	20	26	32	10	101 151	98 148	10-400 401-800
32-25-SAM 20/21	45	12	45	22	15	25	37	11	110 150	108 148	10-350 351-725
40-28-SAM 20/21	55	17	55	17	29	25	32	14	100 150 200	97 147 197	10-457 458-850 851-1350
50-40-SAM 20/21	70	20	70	20	24	35	40	18	135 185 235	128 178 228	10-500 501-1000 1001-1500
63-40-SAM 20/21	80	25	85	14	27	30	30	18	137 187 237	125 175 225	10-610 611-1000 1001-1500
80-50-SAM 20/21	100	30	100	4	22	40	22	25	155 205 255	140 190 240	10-600 601-1100 1101-1600
100-70-SAM 20/21	130	40	130	8	28	52	30	35	185 235 285	162 212 262	10-650 651-1150 1151-1650
125-90-SAM 20/21	150	50	150	15	26	50	37	43	233 313 393	197 277 357	10-750 751-1500 1501-2200

SINGLE ACTING METRIC RANGE

Hydraulic equipment for all uses

◀ BUSHED PIN MOUNTED RAMS with DAMPING & PBV ▶

Bushed pin holes to suit f7 tolerance pins.

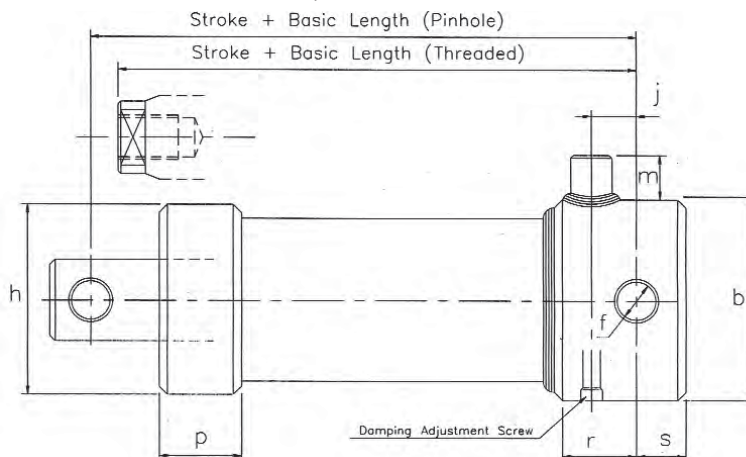

All Dimensions in mm.

Type No.	b	f Ø	h Ø	j	m	p	r	s	Basic Length (Pin.)	Basic Length (Thr.)	Stroke Range
25-19-SAM 22/23	45	10	44.5	19	28	26	34	10	128 178	125 175	10-400 401-800
32-25-SAM 22/23	45	12	45	22	28	25	37	11	132 172	130 170	10-350 351-725
40-28-SAM 22/23	55	17	55	24	28	25	38	14	121 171 221	118 168 218	10-457 458-850 851-1350
50-40-SAM 22/23	70	20	70	20	24	35	38	18	145 195 245	138 188 238	10-500 501-1000 1001-1500
63-40-SAM 22/23	80	25	85	28	15	30	44	18	158 208 258	146 196 246	10-610 611-1000 1001-1500
80-50-SAM 22/23	100	30	100	30	15	40	47	25	181 231 281	166 216 266	10-600 601-1100 1101-1600
100-70-SAM 22/23	130	40	130	36	12	52	56	35	220 270 320	197 247 297	10-650 651-1150 1151-1650
125-90-SAM 22/23	150	50	150	46	13	50	56	43	298 378 458	262 342 422	10-750 751-1500 1501-2200

SINGLE ACTING METRIC RANGE

Hydraulic equipment for all uses

◀ SPHERICAL EYE MOUNTED RAMS with PBV ▶

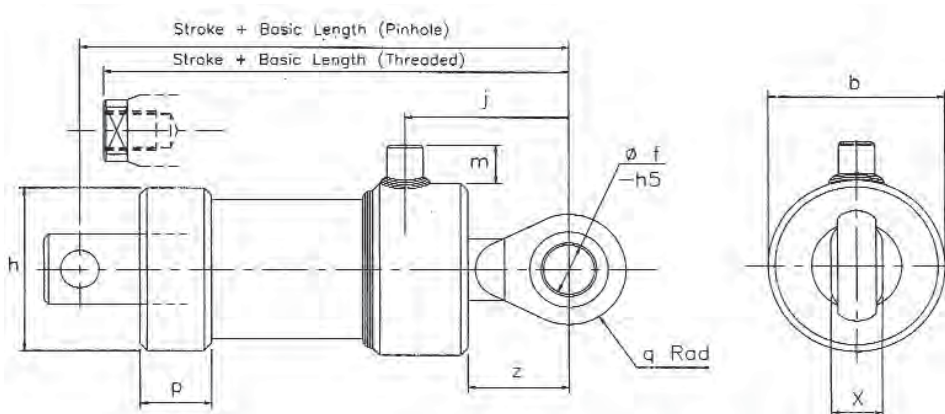

All Dimensions in mm.

Type No.	b Ø	f Ø	h Ø	j	m	p	q	x	z	Basic Length (Pin.)	Basic Length (Thr.)	Stroke Range
25-19-SAM 36/37	38	10	45	46	19	26	15	9	24	135 185	132 182	10-400 401-800
32-25-SAM 36/37	45	12	45	48	15	25	17	10	27	135 117	133 117	10-350 351-725
40-28-SAM 36/37	55	17	55	56	15	25	23	14	35	144 194 244	141 191 241	10-457 458-850 851-1350
50-40-SAM 36/37	70	20	70	59	24	35	26.5	16	38	175 225 275	168 218 268	10-500 501-1000 1001-1500
63-40-SAM 36/37	76	25	85	65	22	30	32	20	45	190 240 290	178 223 278	10-610 611-1000 1001-1500
80-50-SAM 36/37	100	30	100	69	15	40	36.5	22	51	219 269 319	204 254 304	10-600 601-1100 1101-1600
100-70-SAM 36/37	115	40	130	94	12	52	46	28	69	267 317 367	244 294 344	10-650 651-1150 1151-1650
125-90-SAM 36/37	150	50	150	113	12	50	56	35	88	333 413 493	297 377 457	10-750 751-1500 1501-2200

SINGLE ACTING METRIC RANGE

Hydraulic equipment for all uses

◀ SPHERICAL EYE MOUNTED RAMS with DAMPING & PBV ▶

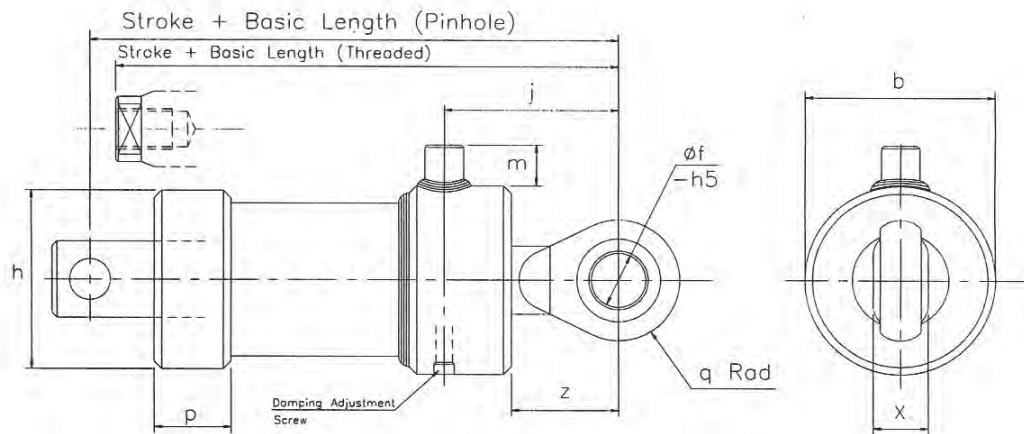

All Dimensions in mm.

Type No.	b Ø	f Ø	h Ø	j	m	p	q	x	z	Damped Length	Basic Length (Pin.)	Basic Length (Thr.)	Stroke Range
25-19-SAM 38/39	45	10	45	46	28	26	15	9	24	15	155 205	152 202	10-400 401-800
32-25-SAM 38/39	45	12	45	49	28	25	17	10	27	15	159 199	157 197	10-350 351-725
40-28-SAM 38/39	55	17	55	56	28	25	23	14	35	25	153 203 253	150 200 250	10-457 458-850 851-1350
50-40-SAM 38/39	70	20	70	59	24	35	26.5	16	38	25	186 236 286	179 229 279	10-500 501-1000 1001-1500
63-40-SAM 38/39	76	25	85	65	22	30	32	20	45	25	197 247 297	185 235 285	10-610 611-1000 1001-1500
80-50-SAM 38/39	100	30	100	69	15	40	36.5	22	51	25	219 269 319	204 254 304	10-650 651-1150 1151-1650
100-70-SAM 38/39	115	40	130	94	12	52	46	28	69	25	276 326 376	253 323 353	10-650 651-1150 1151-1650
125-90-SAM 38/39	150	50	150	113	13	50	56	35	88	25	369 449 529	333 413 493	10-750 751-1500 1501-2200

SINGLE ACTING METRIC RANGE

Hydraulic equipment for all uses

◀ FRONT FLANGE MOUNTED RAMS with PBV ▶

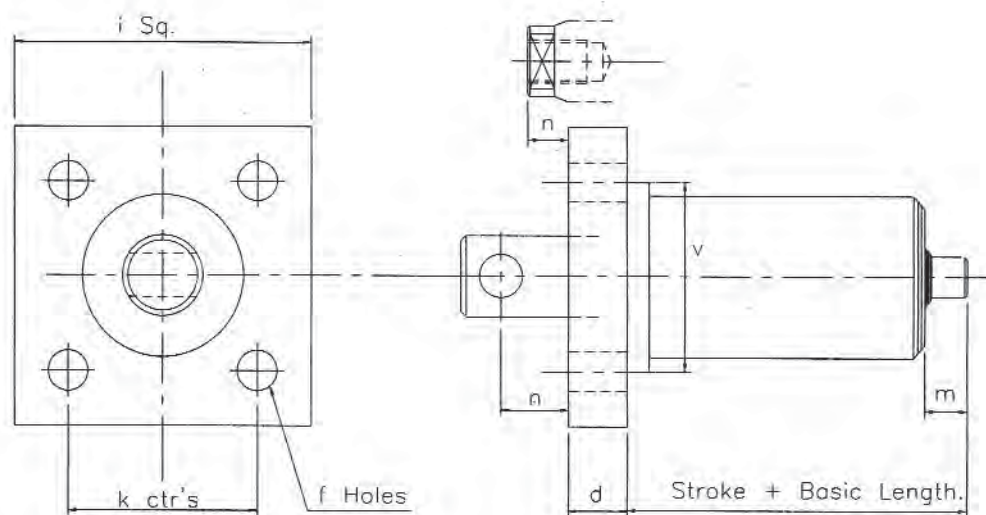

All Dimensions in mm.

Type No.	d	f Ø	i	k	m	n (Pin.)	n (Thr.)	v Ø	Basic Length	Stroke Range
25-19-SAM 52/53	10	6.35	60	45	23	13	10	47	113 163	10-400 401-800
32-25-SAM 52/53	18	9	70	50	23	14	12	50	111 151	10-350 351-725
40-28-SAM 52/53	20	8.5	80	60	23	17	14	60	126 176 226	10-457 458-850 851-1350
50-40-SAM 52/53	23	10.5	90	65	15	22	15	70	130 180 230	10-500 501-1000 1001-1500
63-40-SAM 52/53	23	12.5	114	80	19	28	16	82	131 181 231	10-610 611-1000 1001-1500
80-50-SAM 52/53	23	16.5	130	100	15	33	18	110	150 200 250	10-400 401-750 751-1100
100-70-SAM 52/53	28	21	160	120	18	45	22	130	164 214 264	10-650 651-1150 1151-1650
125-90-SAM 52/53	35	25	200	150	18	60	24	160	193 273 335	10-1000 1001-1600 1601-2200

SINGLE ACTING METRIC RANGE

Hydraulic equipment for all uses

◀ REAR FLANGE MOUNTED RAMS with PBV ▶

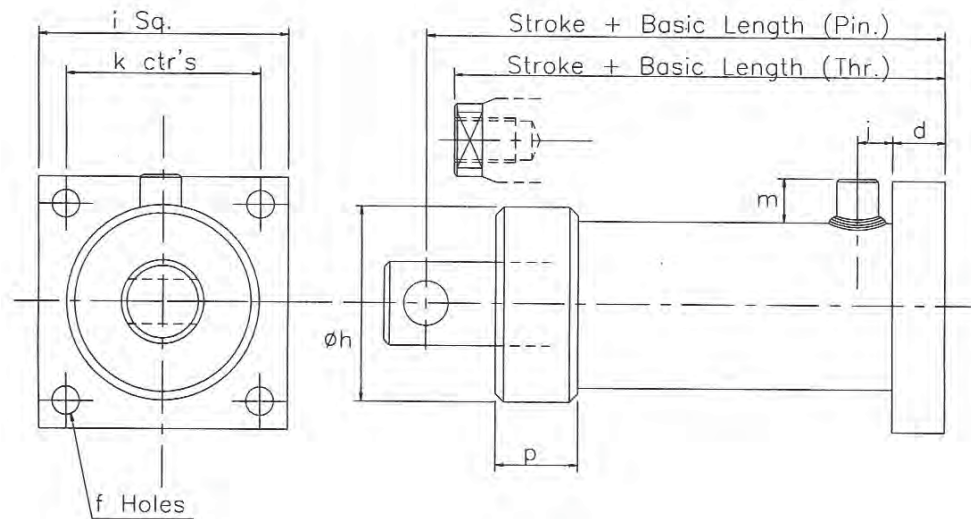

All Dimensions in mm.

Type No.	d	f Ø	h Ø	i	j	k	m	p	Basic Length (Pin.)	Basic Length (Thr.)	Stroke Range
25-19-SAM 68/69	10	6.35	44.5	60	22	45	19	26	121 171	118 168	10-400 401-800
32-25-SAM 68/69	18	9	45	70	27	50	15	25	133 183	131 181	10-350 351-725
40-28-SAM 68/69	20	8.5	55	80	27	60	15	25	135 185 235	132 182 232	10-457 458-850 851-1350
50-40-SAM 68/69	23	10.5	70	90	21	65	24	35	160 210 260	153 203 253	10-500 501-1000 1001-1500
63-40-SAM 68/69	23	12.5	85	114	20	80	22	30	168 218 268	156 206 256	10-610 611-1000 1001-1500
80-50-SAM 68/69	23	16.5	100	130	28	100	15	40	201 251 301	186 236 286	10-600 601-1100 1101-1600
100-70-SAM 68/69	28	21	130	160	25	120	18	52	226 276 326	203 253 303	10-650 651-1150 1151-1650
125-90-SAM 68/69	35	25	150	200	28	150	12	50	280 360 440	244 324 404	10-750 751-1500 1501-2200

SINGLE ACTING METRIC RANGE

Hydraulic equipment for all uses

◀ TRUNNION MOUNTED RAMS with PBV ▶

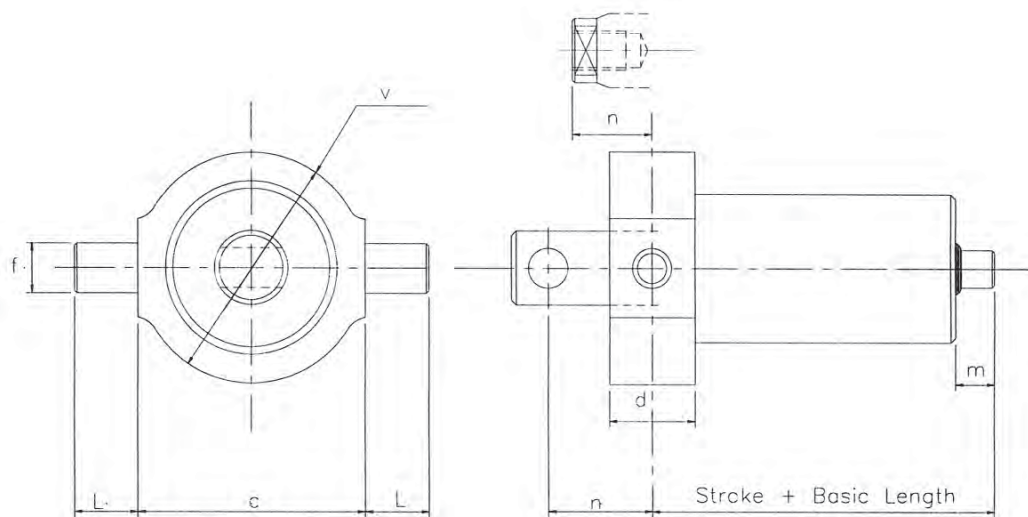

All Dimensions in mm.

Type No.	c	d	f Ø	l	m	n (Pin.)	n (Thr.)	v Ø	Basic Length	Stroke Range
25-19-SAM 100/101	50	30	10	16	23	28	25	50	106 156	10-400 401-800
32-25-SAM 100/101	55	38	12	18	23	33	31	55	115 155	10-350 351-725
40-28-SAM 100/101	65	34	17	20	23	34	31	65	109 259 309	10-457 458-850 851-1350
50-40-SAM 100/101	80	48	20	25	15	46	39	80	121 171 221	10-500 501-1000 1001-1500
63-40-SAM 100/101	100	34	25	35	19	45	33	95	114 164 214	10-610 611-1000 1001-1500
80-50-SAM 100/101	120	38	30	45	15	52	37	120	131 181 231	10-400 401-750 751-1100
100-70-SAM 100/101	140	52	40	50	18	71	48	140	138 188 238	10-650 651-1150 1151-1650
125-90-SAM 100/101	180	66	50	60	18	93	57	180	160 240 320	10-1000 1001-1600 1601-2200

SINGLE ACTING METRIC RANGE

Hydraulic equipment for all uses

◀ TRUNNION MOUNTING BLOCKS ▶

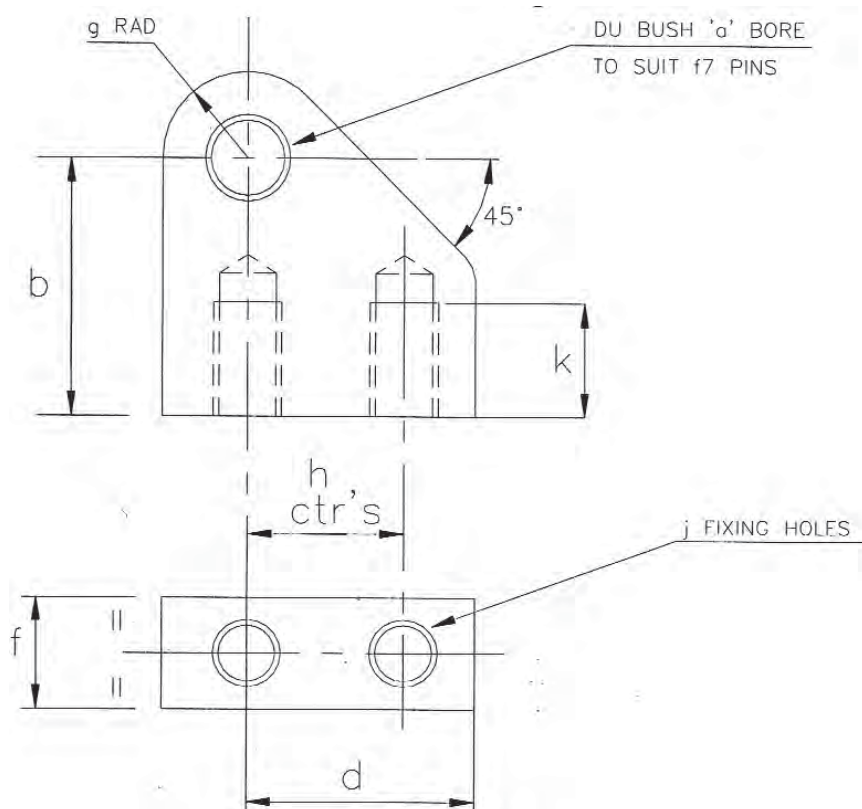

All Dimensions in mm.

Part No. (pair)	a Ø	b	d	f	g	h	j	k
25-16-0350	10	30	30	15	12	22	M8	15
32-20-0351	12	35	35	18	13	25	M10	18
40-28-0353	17	40	40	20	18	30	M12	18
50-28-0353	20	45	45	24	20	32	M16	22
63-40-0354	25	55	55	33	25	38	M20	25
80-50-0351	30	65	65	43	30	45	M24	30
100-70-0354	40	80	80	48	38	55	M30	35
125-70-0350	50	100	100	58	50	70	M36	50

SINGLE ACTING METRIC RANGE

Hydraulic equipment for all uses

◀ CLEVIS EYE, PLAIN & BUSHED ▶

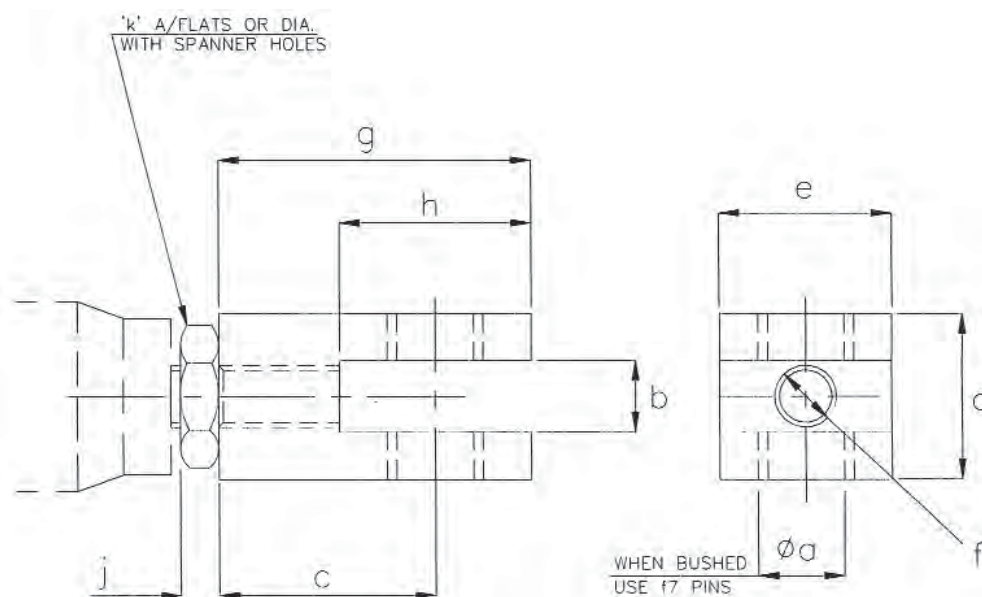

All Dimensions in mm.

Part No. without Bush #	Part No. with Bush *	Lock Nut Part No.	a #	a * Ø	b	c	d	e	f	g	h	j	k
25-16-0270	25-16-0271	25-16-0480	10.5	10	13	35	30	20	M10x1.5	45	27	6	17
32-20-0271	32-20-0272	32-20-0480	12.5	12	20	42	40	25	M12x1.75	55	32	7	19
40-28-0274	40-28-0275	40-28-0482	17.5	17	20	60	40	40	M16x2	80	45	9	24
50-28-1270	50-28-1271	50-28-0480	20.5	20	23	68	45	45	M20x1.5	90	50	9	30
63-40-1275	63-40-1276	63-40-0482	25.4	25	26	80	57	57	M24x2	108	60	10	36
80-50-1271	80-50-1273	80-50-0455	30.5	30	20	93	63.5	63.5	M30x2	125	70	12	45
100-70-1276	100-70-1277	100-70-0452	40.5	40	40	115	80	80	M39x3	155	90	16	55
125-70-0271	125-70-0272	125-70-0451	50.5	50	52	135	114	114	M45x3	190	120	18	65

SINGLE ACTING METRIC RANGE

Hydraulic equipment for all uses

◀ SPHERICAL EYES ▶

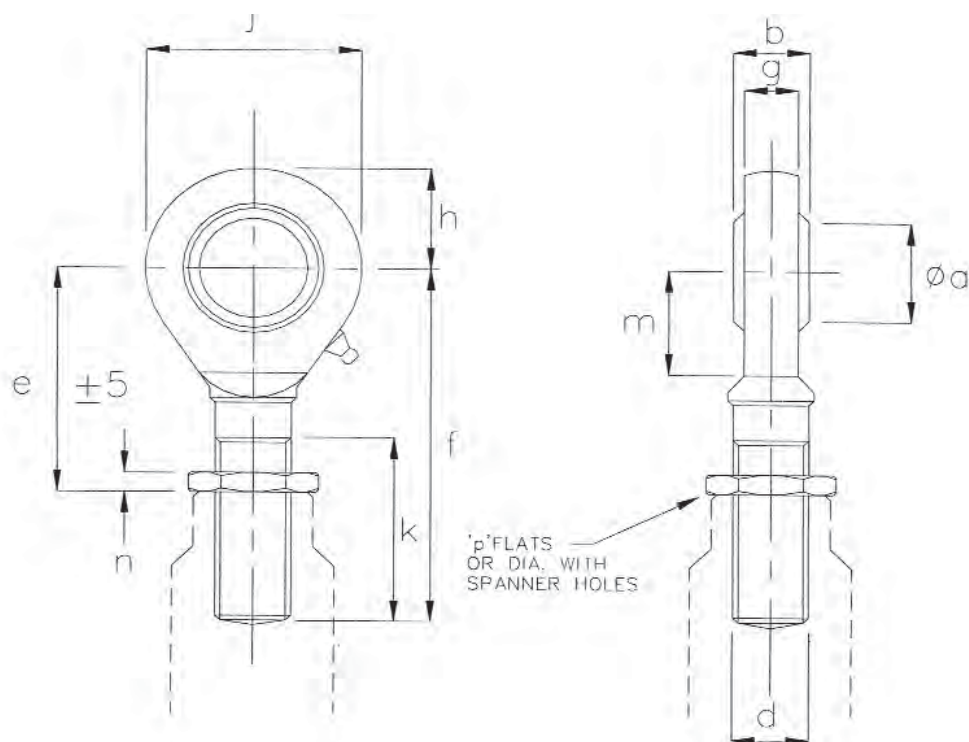

All Dimensions in mm.

End Eye Part No.	Lock Nut Part No.	a h5 Ø	b	d	e	f	g	h	j	k	m	n	p
25-16-0436	25-16-0480	10	9	M10x1.5	33	48	7	15	27	26	14	6	17A/F
32-20-0431	32-20-0480	12	10	M12x1.75	38	54	8	17	31	28	16	7	19A/F
40-28-0439	40-28-0482	17	14	M16x2	47	69	11	22.5	41	36	20	9	24A/F
50-28-0438	50-28-0480	20	16	M20x1.5	49	78	13	25.5	47	43	23	9	30A/F
63-40-0433	63-40-0482	25	20	M24x2	56	94	17	30	55	53	27	10	36A/F
80-50-0437	80-50-0455	30	22	M30x2	62	110	19	35	65	65	30	12	45DIA
100-70-0438	100-70-0452	40	28	M39x3	85	150	23	48	88	86	44	16	55DIA
125-70-0437	125-70-0451	50	35	M45x3	104	185	30	61	111	104	58	18	63.5DIA

SINGLE ACTING METRIC RANGE

Hydraulic equipment for all uses

◀ SPARES ▶

We supply an extensive range of hydraulic spares for every item that we have manufactured, including piston rods, cylinders and seal kits. Please ensure that you always state the ram serial number when ordering spares. This will be stamped onto the bottom end or around the flange or trunnion.

◀ INSTALLATION & MAINTENANCE ▶

1. STORAGE ▶

Port plug must always be left in until pipe connections are to be made.
Rams should be oiled and stored in a clean dry atmosphere. They should be vertical to prevent seal set and should not be stored for in excess of 24 months without manufacturers overhaul.

2. INSTALLATION ▶

Piping must be thoroughly cleaned and deburred before connection. Sealing agents such as hemp and putty must not be used.
Ensure all moving surfaces are correctly lubricated.
Rams must be installed free from bending forces and side loads.
Initially the system should be cycled at low pressure.
All air must be bled from the system to ensure satisfactory function. This may be carried out by cracking pipe joints at the highest points in the system.
Only agreed types and grades of fluids may be used.

3. MAINTENANCE ▶

Good fluid condition is essential for maximum ram life. Contaminated or aged fluid should be replaced, not topped up.
If the rod or bore shows signs of marking the unit should be returned to the manufacturer for overhaul. Seal life is dependent on working conditions, particularly the fluid condition, working atmosphere, temperature and speed. Impulse and shock pressures are especially inclined to reduce seal life.
Ensure system pressure is dumped and loads are otherwise supported before attempting maintenance.
Rams should be thoroughly cleaned prior to reassembly.
Abrasive dust and chemicals should not be allowed on, or around, the piston rod as this will advance seal wear and may initiate rod corrosion.