

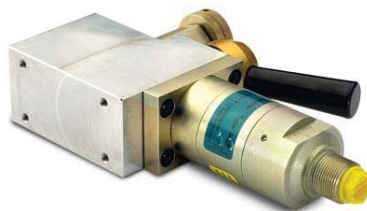

Valve Housing CV3 – with Control Valve & PRV



The miniBOOSTER valve housing is used for mounting various accessory components directly to the miniBOOSTER. This saves space and reduces the cost of using stand alone components for these functions. The valve housing and components selected will be factory mounted, tested and sized based on the model of miniBOOSTER selected. Housing material, aluminum.

Description

The CV3 incorporates a Pressure Reducing Valve (PRV) to control inlet pressure to the miniBOOSTER, an optional orifice to reduce inlet flow to the maximum allowed for the intensification ratio selected, and a 4/3 Control Valve to direct flow in the forward, dump, and neutral positions. Both manually operated and solenoid operated valves are available.



Dimensions (valve housing CV3 for HC2, HC7 & HC8)

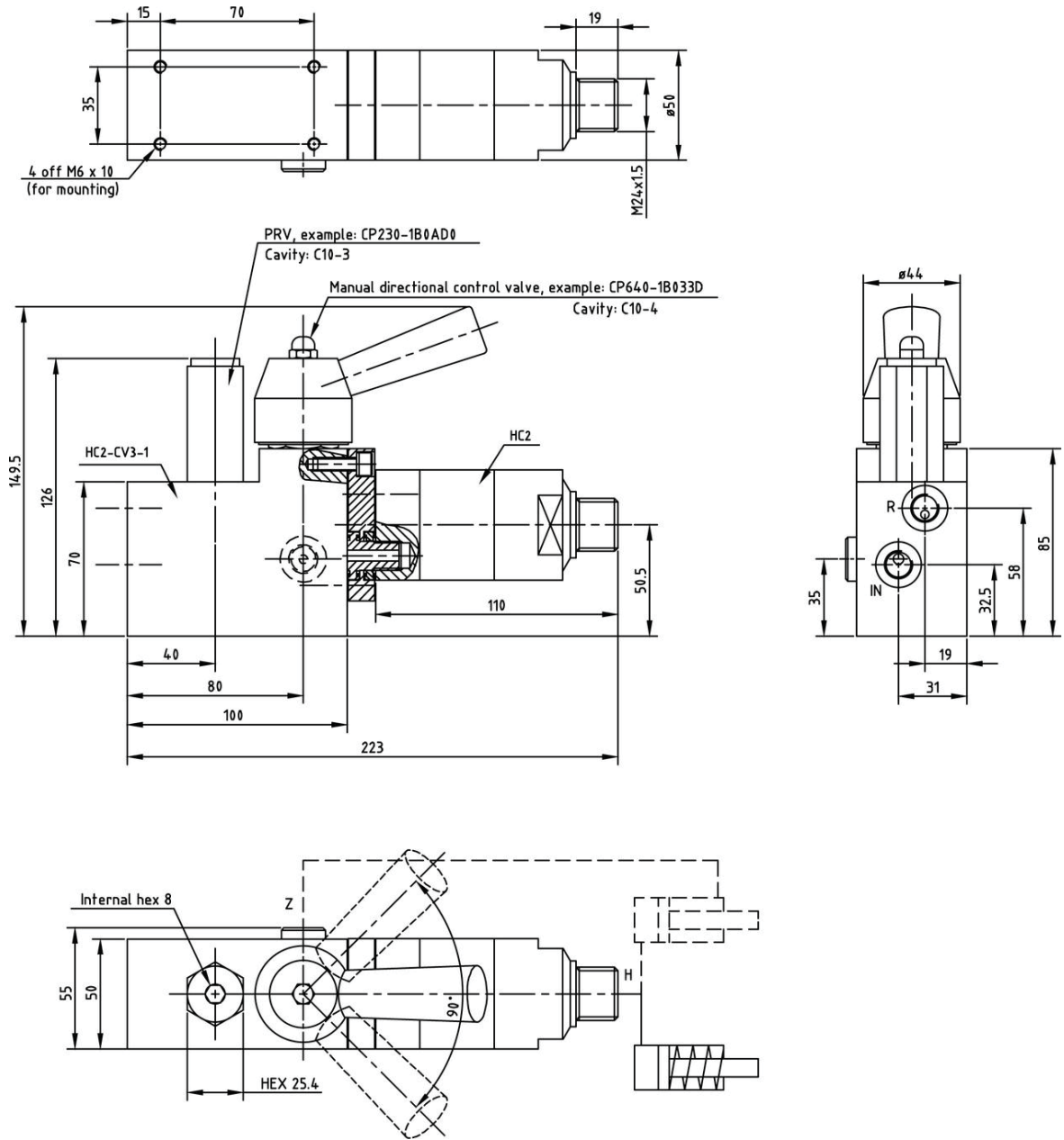

0-315

Dimensions (valve housing CV3 for HC4)

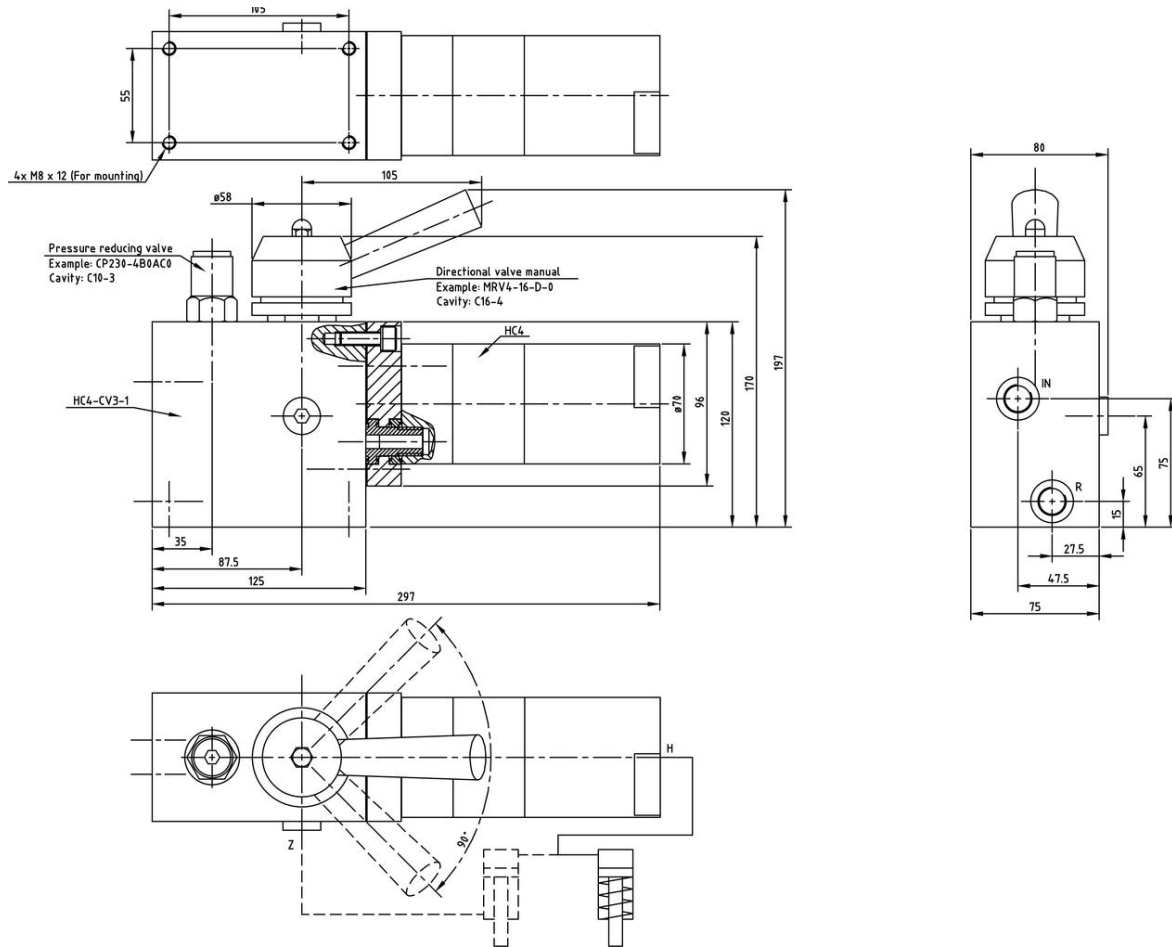

Functions

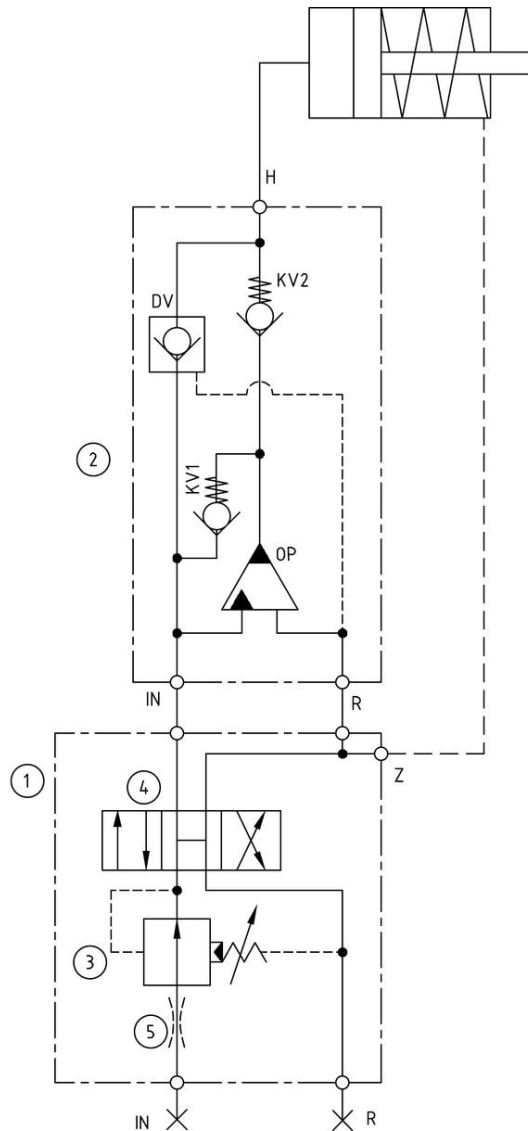

Function Diagram 1. Orifice (Optional) 2. PRV Cartridge (C10-3 Style) 3. 4/3 Cartridge (C10-4 Style) 4. Housing 5. HC2, HC4, HC7 or HC8

Ordering a valve housing CV3 for HC2

Example of ordering a complete unit:
1 off Valve housing HC2 – CV3 – 1
1 off Pressure reducing valve CP-230-1B0AD0, cavity: C10-3
1 off 4/3 Manual Cartridge valve CP640-1B033D, cavity: C10-4
1 off miniBOOSTER HC2 – 4.0 – B – 1

Model	Valve House	Connections
your selection...	CV3	your selection...
For HC2, HC7 and HC8		1 = 1/4" BSP 2 = 7/16 - 20 UNF
HC4		1 = 3/8" BSP 2 = 9/16 - 18 UNF