

Electric Drives  
and Controls

Hydraulics

Linear Motion and  
Assembly Technologies

Pneumatics

Service

**Rexroth**  
Bosch Group

1/12

## 4/3 directional servo-valve with mechanical position feedback

**RE 29564-XN-100-B2/05.10**  
Replaces: 02.09

**Type 4WS2EM 6...XN...-100**

Size 6  
Component series 2X  
Maximum operating pressure 315 bar  
Maximum flow 48 l/min

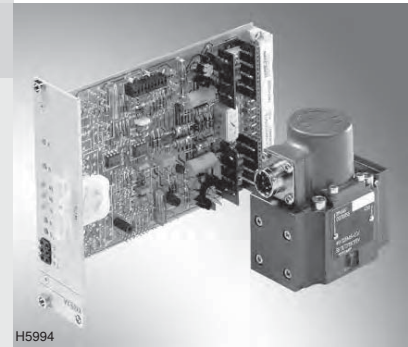

**ATEX units**  
**For explosive areas**

**Part II Technical data sheet**



### Information on explosion protection:

Range of application in accordance with the Explosion Protection Directive 94/9/EC

**II3G:** Type of protection Ex nA II T5X according to  
EN 60079-0:2006 / EN 60079-15:2005

**II3D:** Type of protection Ex tD A22 IP 65 TX according to  
EN 61241-0:2006 / EN 61241-1:2004

### What you need to know about these operating instructions

These operating instructions apply to the explosion-proof version of Rexroth valves and consist of the following three parts:

Part I General information RE 07010-X-B1

Part II Technical data sheet RE 29564-XN-100-B2

Part III Product-specific instructions RE 29564-XN-100-B3

**RE 29564-XN-100-B0**

You can find further information on the correct handling of Rexroth hydraulic products in our publication "General product information on hydraulic products" RE 07008.

## Table of contents

---

Content	Page
Features	2
Ordering code and scope of delivery	3
Symbol	3
Function, section	4
Technical data	5, 6
Information on explosion protection	6
External control electronics	6
Mating connector	7
Electrical connection	7
Characteristic curves	8, 9
Unit dimensions	10
Flushing plate	11

## Features

---

- Directional servo-valve for proper use in explosive areas of zone 2 and 22
- Valve to control position, force, pressure or velocity
- 2-stage servo valve with mechanical feedback
- 1<sup>st</sup> stage as nozzle flapper plate amplifier
- For subplate mounting, porting pattern according to ISO 4401-03-02-0-05 subplates available in FE/ZN version (see page 10)
- Dry control motor, no contamination of the solenoid gaps by the hydraulic fluid
- Can also be used as 3-way version
- Wear-free spool feedback element
- Control:  
External control electronics in Eurocard format or in modular design (separate order), see page 6
- Valve is adjusted and tested
- Pressure chambers at the control sleeve with gap seal, therefore no wear of the seal ring
- Filter for 1<sup>st</sup> stage freely accessible from the outside

## Ordering code and scope of delivery

4WS2EM 6-2X/ B 11 XN ET K17 V-100

Electrically actuated  
2-stage servo valve in  
4/3 directional design with  
mechanical feedback for  
**external control electronics**

Size 6 = 6

Component series 20 to 29 = 2X  
(20 to 29: unchanged installation and  
connection dimensions)

### Rated flow <sup>1)</sup>

2 l/min	= 2
5 l/min	= 5
10 l/min	= 10
15 l/min	= 15
20 l/min	= 20
25 l/min	= 25

Characteristic curves, see page 8  
(observe tolerance field of flow  
signal function)

Valve for **external control electronics** = 11  
coil no. 11 (30 mA/85 Ω per coil) <sup>2)</sup>

100 = special number <sup>6)</sup>

### Seal material

V = FKM seals,  
suitable for mineral oil (HL, HLP)  
according to DIN 51524

### Spool overlap <sup>5)</sup>

E =	0 ... 0.5 % negative
D =	0 ... 0.5 % positive
C =	3 ... 5 % positive

K17 = **electrical connection  
via connector**

Order mating connector separately,  
see page 7

### Inlet pressure range <sup>4)</sup>

210 =	10 to 210 bar
315 =	10 to 315 bar

ET = internal pilot oil supply and return <sup>3)</sup>

XN = explosion protection "type nA"  
For details see information on the explosion protection, page 6

### Included in the delivery:

Valve operating instructions with declaration of conformity in part III

#### 1) Rated flow

The rated flow refers to a 100% command value signal at 70 bar valve pressure differential (35 bar per control edge). The valve pressure differential must be regarded as reference. Other values result in the flow being changed. A possible rated flow tolerance of ±10% must be taken into account (see flow signal function page 8).

#### 2) External control electronics

The actuating signal must be formed by a current controlled output stage. Control electronics (servo amplifier) see page 6.

#### 3) Pilot oil

The valve is only delivered with internal pilot oil supply and return.

#### 4) Inlet pressure range

Care should be taken that the system pressure is as constant as possible.

With regard to the dynamics, the frequency response dependency must be observed within the admissible pressure range of 10 ... 210 bar and/or 10 ... 315 bar.

#### 5) Spool overlap

The spool overlap is specified in % of the control spool stroke.

#### 6) Special number "100"

Without actuation (de-energized condition), channels P → B and A → T are open for 10% of the nominal quantity.

## Symbol

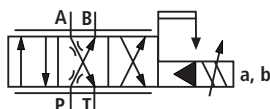

## Function, section

### 4WS2EM 6-2X/...XN...-100

Valves of this type are electrically actuated, 2-stage directional servo-valves with porting pattern according to ISO 4401-03-02-0-05. They are mainly used to control position, force, pressure or velocity.

These valves are made of an electro-mechanical converter (torque motor) (1), a hydraulic amplifier (principle: nozzle flapper plate) (2) and a control spool (3) in a bushing (2nd stage) which is connected with the torque motor via a mechanical feedback.

An electrical input signal at the coils (4) of the torque motor generates a force by means of a permanent magnet which acts on the armature (5), and in connection with a torque tube (6) results in a torque. This causes the flapper plate (7) which is connected to the torque tube (6) via a pin to move from the central position between the two control nozzles (8), and a pressure differential is created across the front faces of the control spool (3). The pressure differential results in the spool changing its position, which results in the pressure port being connected to one actuator port and, at the same time, the other actuator port being connected to the return flow port.

The control spool is connected to the flapper plate or the torque motor by means of a bending spring (mechanical feedback) (9). The position of the spool is changed until the feedback torque across the bending spring and the electro-magnetic torque of the torque motor are balanced and the pressure differential at the nozzle flapper plate system becomes zero.

The stroke of the control spool and consequently the flow of the servo valve are controlled in proportion to the electrical input signal. It must be noted that the flow depends on the valve pressure drop.

#### External control electronics (separate order)

External control electronics (servo amplifier) serve the actuation of the valve, amplifying an analog input signal (command value) so that with the output signal, the servo valve is actuated in a flow-controlled form.

### Type 4WS2EM 6-2X/...XN...-100

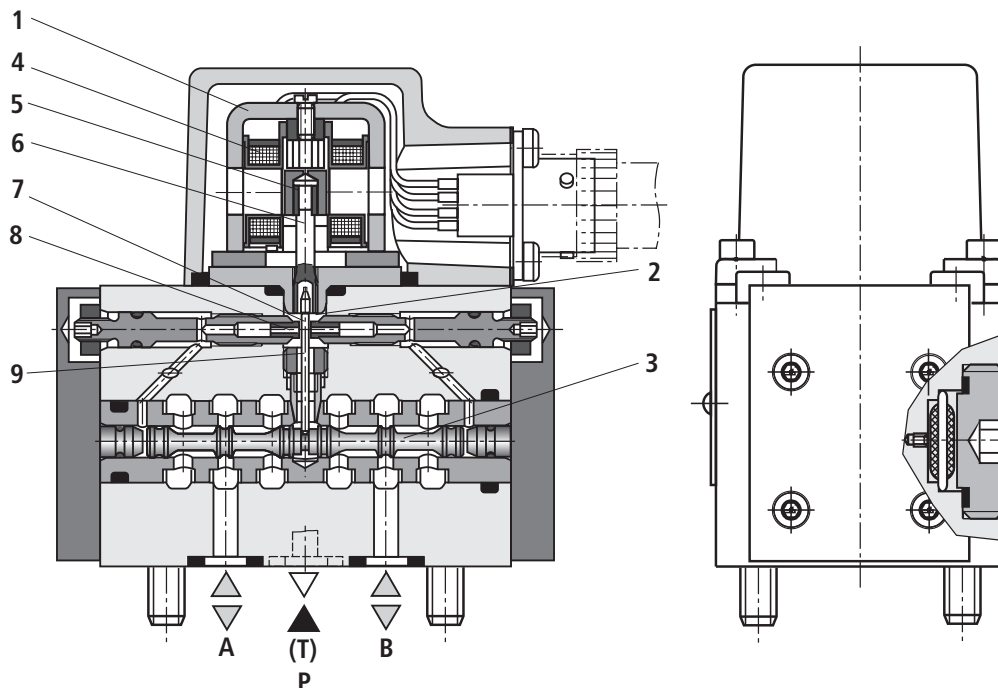

## Technical data

### general

Porting pattern		ISO 4401-03-02-0-05
Installation position		Any (Ensure that upon system start-up, the valve is supplied with enough pressure ( $\geq 10$ bar!))
Surface protection	Valve body, cover, filter screw	Nitro-carburated
	Cap	Anodized
Storage temperature range	°C	-20 ... +80
Ambient temperature range	°C	-30 ... +80
Weight	kg	1.1

### hydraulic (measured with HLP 32, $\vartheta_{oil} = 40^\circ\text{C} \pm 5^\circ\text{C}$ )

Operating pressure	Ports P, A, B	bar	10 ... 210 or 10 ... 315
Return flow pressure	Port T	bar	Pressure peaks < 100, static < 10
Hydraulic fluid			Mineral oil (HL, HLP) according to DIN 51524, ignition temperature > 150 °C
Hydraulic fluid temperature range		°C	-15 ... +80; preferably +40 ... +50
Viscosity range		mm <sup>2</sup> /s	15 ... 380; preferably 30 ... 45
Maximum admissible degree of contamination of the hydraulic fluid cleanliness class according to ISO 4406 (c)			Class 18/16/13 <sup>1)</sup>
Zero flow $q_{v,L}$ <sup>2)</sup> with spool overlap E measured without dither signal		l/min	$\sqrt{p_p / 70 \text{ bar}} \cdot (0.4 \text{ l/min} + 0.02 \cdot q_{v, \text{rated}})$ <sup>3); 4)</sup>
Rated flows $q_{v, \text{rated}}$ <sup>3)</sup> , tolerance $\pm 10\%$ with valve pressure differential $\Delta p = 70$ bar		l/min	2; 5; 10; 15; 20; 25
Max. control spool stroke possible with mechanical end position (in case of error) related to nominal stroke		%	120 ... 170
Feedback system			Mechanical
Hysteresis (dither-optimized)		%	$\leq 1.5$
Range of inversion (dither-optimized)		%	$\leq 0.2$
Response sensitivity (dither-optimized)		%	$\leq 0.2$
Pressure gain with 1 % spool stroke change (from the hydraulic zero point)		% of $p_p$ <sup>4)</sup>	$\geq 50$
Zero adjustment flow over the entire operating pressure range		%	$\leq 3$ , long-term $\leq 5$
Zero shift upon change of:			
Hydraulic fluid temperature		% / 20 °C	$\leq 1$
Ambient temperature		% / 20 °C	$\leq 1$
Operating pressure 80 ... 120 % of $p_p$ <sup>4)</sup>		% / 100 bar	$\leq 2$
Return flow pressure 0 ... 10 % of $p_p$ <sup>4)</sup>		% / bar	$\leq 1$

<sup>1)</sup> The cleanliness classes specified for the components must be adhered to in hydraulic systems. Effective filtration prevents faults and at the same time increases the service life of the components.

For the selection of filters, see technical data sheets RE 50070, RE 50076 and RE 50081.

<sup>2)</sup>  $q_{v,L}$  = Zero flow in l/min

<sup>3)</sup>  $q_{v, \text{rated}}$  = Rated flow in l/min

<sup>4)</sup>  $p_p$  = Operating pressure in bar

## Technical data

### electric

Protection class according to EN 60529:1991+A1:2000	IP 65 with mating connector correctly mounted and locked		
Type of signal	analog		
Rated current per coil	mA	30	
Resistance per coil	Ω	85	
Inductivity with 60 Hz and 100% rated current	Connection in series	H	1.0
	Connection in parallel	H	0.25

In case of actuation using non-Rexroth amplifiers, we recommend a superimposed dither signal

## Information on explosion protection

Range of application as per directive 94/9/EC	II 3 G; II 3 D		
Type of protection according to EN 60079-0:2006 / EN 60079-15:2005	Ex nA II T5X		
Type of protection according to EN 61241-0:2006 / EN 61241-1:2004	Ex tD A22 IP 65 TX		
Maximum surface temperature	°C	100	
Ambient temperature range	°C	-30 ... +80	
Hydraulic fluid temperature range	°C	-15 ... +80	
Max. admissible operating voltage of the servo amplifier	V	32 (DC)	
Conditions for use in zone 2 and 22	The valve may only be used in explosive zones of device group II, category 3, with "low" risk of mechanical hazards according to the harmonized standards EN 60079-0:2006, section 26.4.2 and EN 61241-0:2006, section 23.4.2.1. If used in zones with a "high" risk of mechanical load according to these standards, the user must take measures with a "low" risk of mechanical load.		

## External control electronics

Servo amplifier (separate order)	Eurocard format	Analog	Type VT-SR2-1X/.60 according to technical data sheet RE 29980
	Modular design	Analog	Type VT 11021 according to technical data sheet RE 29743

The coils of the valve may only be connected to these amplifiers in parallel!

### **⚠ WARNING – Risk of explosion**

– The external servo amplifier must be operated outside the explosive area!

## Mating connector

The servo valve may only be supplied through this mating connector. Separate order, material no. **R901043330**

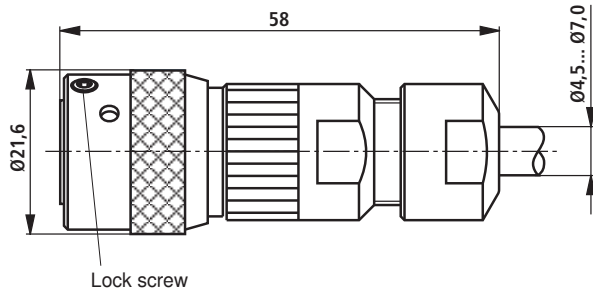

### Connection:

Contact bushings with connection cross-section for litz wires 0.4 ... 0.75 mm<sup>2</sup> are supplied unpacked.

The connection of the litz wires to the contact bushings is possible by crimping or soldering.

A list of the required tools for crimping connection is available in the assembly instructions which are supplied with the mating connector.

## Electrical connection (example of parallel connection)

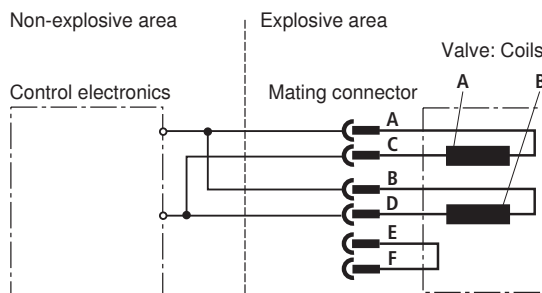

The coils are connected in parallel in the mating connector or at the amplifier (see figure).

In case of serial connection, contacts B and C must be connected.

The E-F bridge can be used for the electrical determination of the correct connection of the plug-in connector and/or for the identification of cable break.

The electrical actuation from A (+) to D (-) causes flow direction from P → A and B → T. The reverse electrical actuation causes flow direction from P → B and A → T.

## Characteristic curves (measured with HLP 32, $\vartheta_{oil} = 40^\circ\text{C} \pm 5^\circ\text{C}$ )

**Flow/load function** (tolerance  $\pm 10\%$ ) with 100 % command value signal

Note:

Observe flow values in the max. command value range (see tolerance field of the flow/signal function)

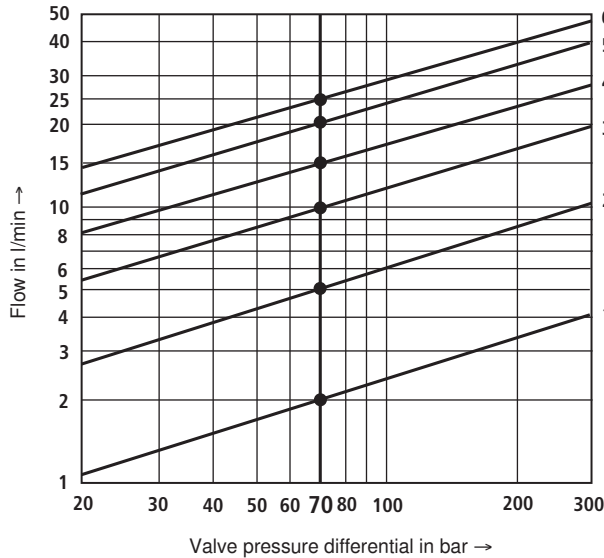

Ordering code	Rated flow	Curve
2	2 l/min	1
5	5 l/min	2
10	10 l/min	3
15	15 l/min	4
20	20 l/min	5
25	25 l/min	6

$\Delta_p$  = Valve pressure differential  
(inlet pressure  $p_p$   
minus load pressure  $p_L$   
minus return flow pressure  $p_T$ )

## Tolerance field of flow/signal function

at constant valve pressure difference  $\Delta_p$

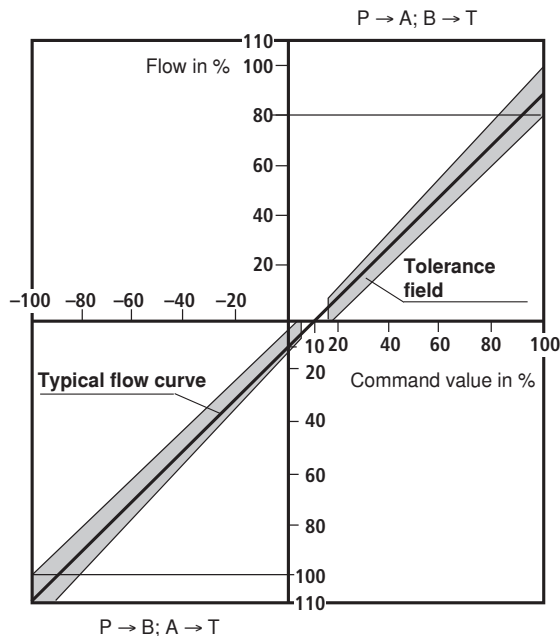

## Characteristic curves (measured with HLP 32, $\vartheta_{oil} = 40^\circ\text{C} \pm 5^\circ\text{C}$ )

Transition function with pressure rating 315 bar, step response without flow

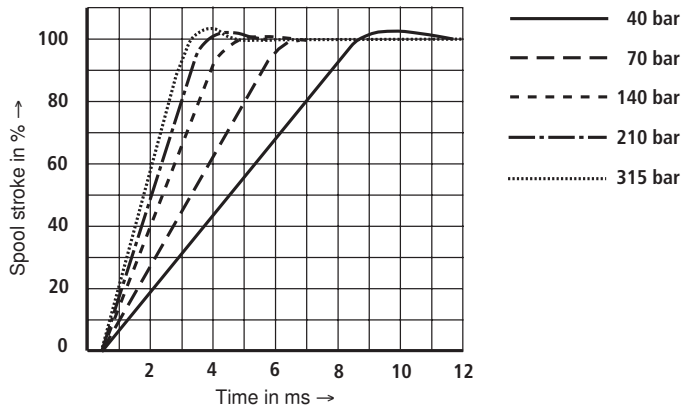

Frequency response with pressure rating 315 bar, stroke frequency without flow

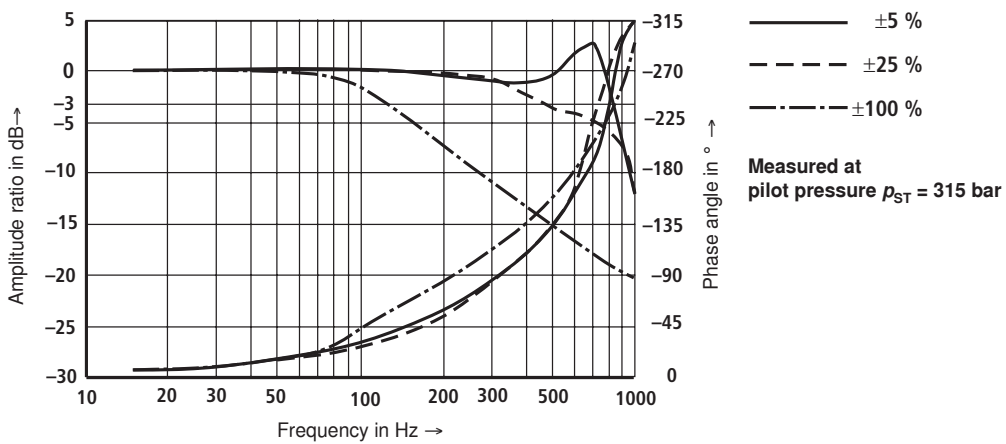

Dependency of the frequency  $f$  at  $-90^\circ$  on the operating pressure  $p$  and the inlet amplitude

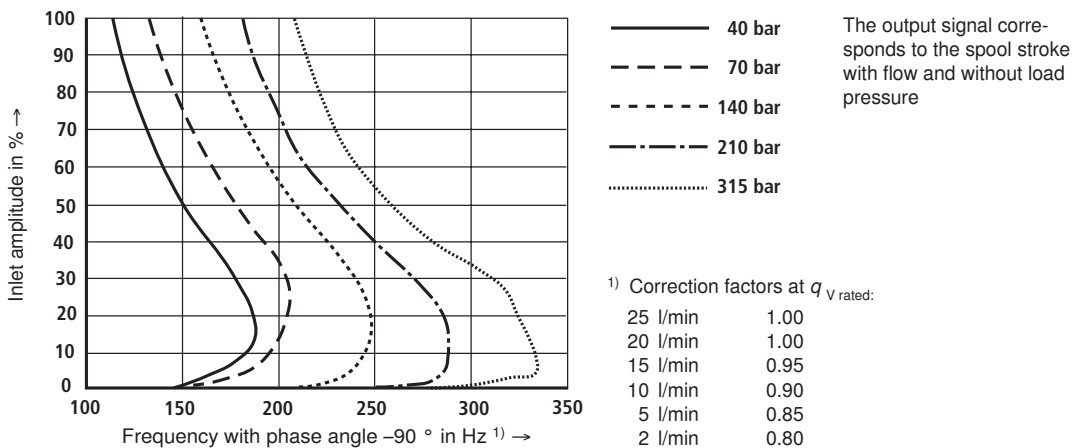

## Unit dimensions (dimensions in mm)

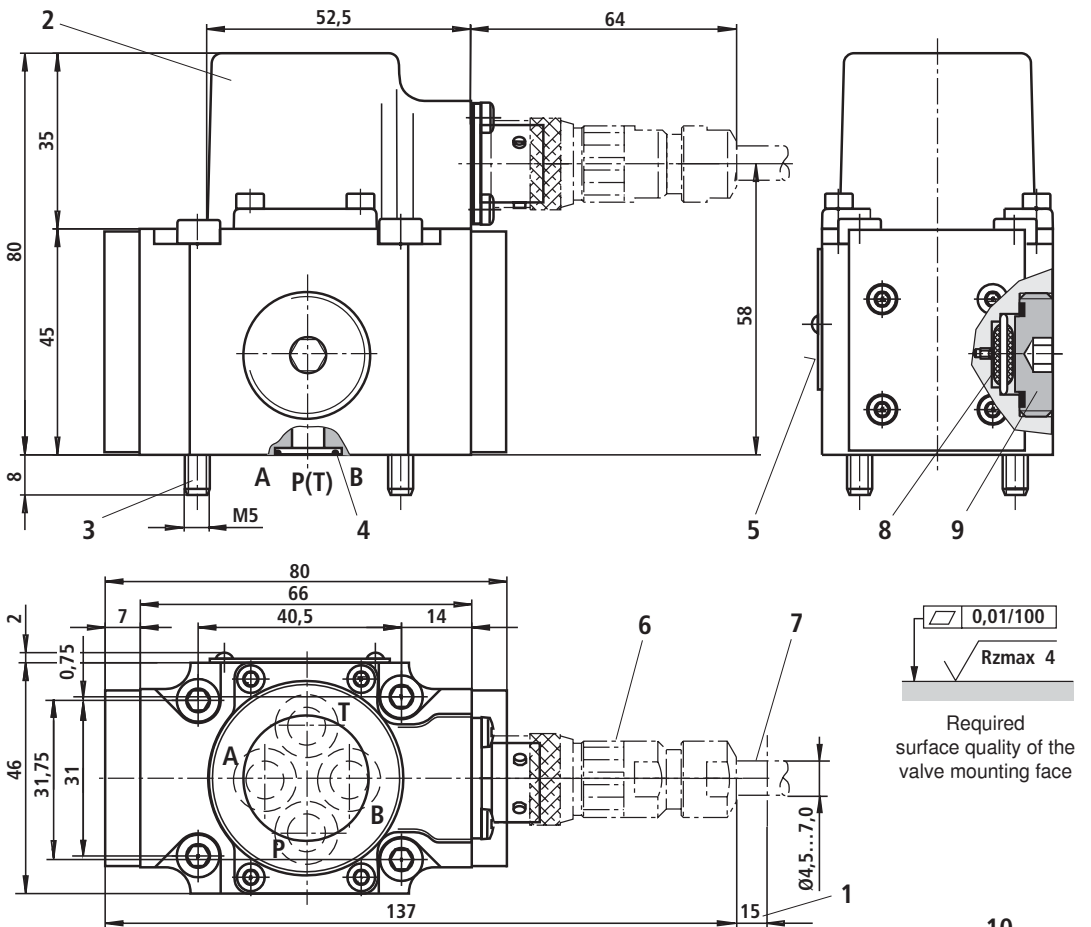

- 1 Required space for the removal of mating connectors, additionally observe the bending radius of the connection line
- 2 Cap
- 3 Valve mounting screws  
For reasons of stability, exclusively the following valve mounting screws may be used:  
**4 hexagon socket head cap screws ISO 4762-M5x50-10.9-fZn-240h-L (Friction coefficient 0.09 – 0.14 according to VDA 235-101) (included in the delivery)**
- 4 Identical seal rings for ports P, A, B and T
- 5 Name plate
- 6 Mating connector (order separately, see page 7)
- 7 Connection line, further information on page 7
- 8 Filter
- 9 Plug screw
- 10 Machined valve mounting face, porting pattern according to ISO 4401-03-02-0-05  
Deviating from the standard:  
– Locating pin not available (G)

### Subplates

G341/01 FE/ZN (G1/4)  
G342/01 FE/ZN (G3/8)  
G502/01 FE/ZN (G1/2)  
with dimensions as in the technical data sheet RE 45052 (must be ordered separately)

### Note:

Subplates are no components in the sense of directive 94/9/EC and can be used after the manufacturer of the overall system has assessed the risk of ignition. The G...FE/ZN versions are free from aluminum and/or magnesium and galvanized.

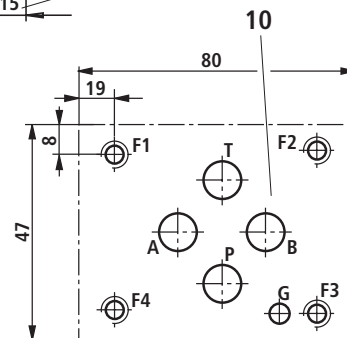

## Flushing plate with porting pattern according to ISO 4401-03-02-0-05 (dimensions in mm)

### Symbol



### Ordering code and more information

- Material number: **R900936049**
- Weight: 0.6 kg
- Identical seal rings for ports P, A, B and T
- Mounting screws  
For reasons of stability, exclusively the following mounting screws may be used:  
**4 hexagon socket head cap screws  
ISO 4762-M5x40-10.9-fIZn-240h-L  
(Friction coefficient 0.09 - 0.14 according to  
VDA 235-101) (included in the delivery)**

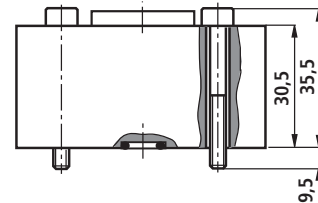

### Note

Before the assembly, observe the information in the product-specific instructions RE 29564-XN-100-B3, section 3.2.

## Notes

---

© This document, as well as the data, specifications and other information set forth in it, are the exclusive property of Bosch Rexroth AG. It may not be reproduced or given to third parties without its consent. The data specified above only serve to describe the product. No statements concerning a certain condition or suitability for a certain application can be derived from our information. The information given does not release the user from the obligation of own judgment and verification. It must be remembered that our products are subject to a natural process of wear and aging.