

Electric Drives  
and Controls

Hydraulics

Linear Motion and  
Assembly Technologies

Pneumatics

Service

**Rexroth**  
Bosch Group

## Multi-station manifold blocks

RE 48107/04.06  
Replaces: 10.05

1/8

### Type HSR 06

Nominal size 6  
Component series 2X; 3X  
Maximum operating pressure 315 bar

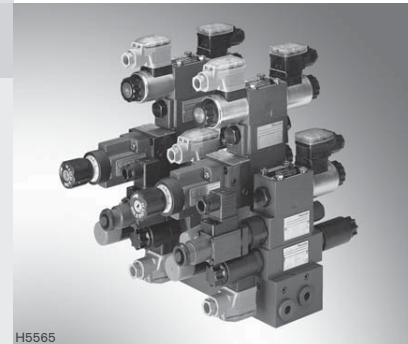

### Overview of contents

Contents	Page
Features	1
Ordering details	2
Unit dimensions	3 to 6
Fixing screws and permissible operating pressure	7 and 8
Engineering guidelines	8

### Features

- Multi-station manifold blocks form the basis for ready to connect, as vertical stacking assemblies, control circuits
- Very compact hydraulic circuits can be built-up on each axis, using vertically stacked sandwich plate valves in combination with NS6 directional control valves or proportional valves.
- All circuits have a common pressure and tank port which are positioned on each end of the manifold.
- Each control station has separate actuator ports A and B, which can be on the side (version C) or on the underside (version D) as required.

### Features

- The following are available as vertical stacking assemblies:
  - Pressure reducing valve ZDR to RE 26570
  - Pressure relief valve ZDB to RE 25751
  - Double check valve Z2S to RE 21548
  - Check valve Z1S to RE 21533
  - Double throttle check valve Z2FS to RE 27506
  - Pressure switch HED 8 to RE 50060
  - Sandwich plates to RE 48050
  - Directional valve:
    - Electrical operation, type WE to RE 23178
    - Fluidic operation, types WH and WP to RE 22282
    - Mechanical, manual operation, type WM... to RE 22280
  - Proportional valve:
    - Direct operated, without feedback, type WRA to RE 29055
    - Direct operated with electrical feedback, type WRE to RE 29061
  - Blanking plate, Material No. **R900316232**

### Ordering details: manifold without built-on valves

<b>PLATTE</b>	<b>HSR 06</b>	/		*
---------------	---------------	---	--	---

**No. of control circuit stations in a vertical stacking assembly**

for 1 control (on request)	= 1
for 2 controls	= 2
for 3 controls	= 3
for 4 controls	= 4
for 5 controls	= 5
for 6 controls	= 6
for 7 controls	= 7
for 8 controls	= 8
for 9 controls	= 9
for 10 controls	= 10

Manifolds with

- Test points
- Pressure reducing function as well as
- Other functions on request!

**Further details in clear text**

**C =** Actuator ports on side  
**D =** Actuator ports on underside

**01 =** Pipe threads to ISO 228 part 1  
**02 =** Metric ISO threads to DIN 3852 part 1  
**03 =** NPT threads

**2X =** Component series 20 to 29 (20 to 29: unchanged installation and connecting dimensions)  
**With enlarged connection threads**  
**3X =** Component series 30 to 39 (30 to 39: unchanged installation and connecting dimensions)

**06 =** Nominal size 6

**To order a multi-station manifold block with built-on valves see below.**

### Required ordering details example for a manifold block assembly

**Example:**  
2-station manifold block to circuit diagram HS-115-B234

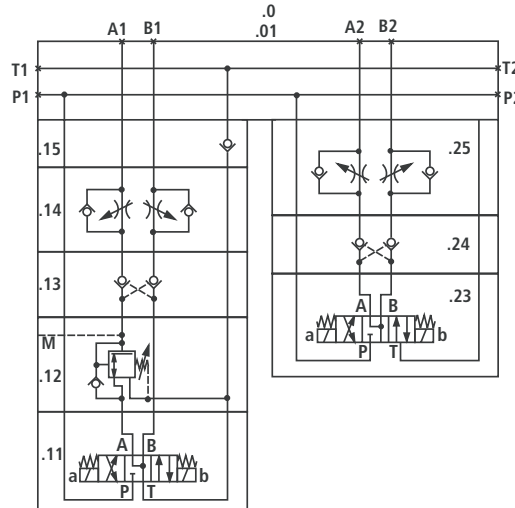

<sup>1)</sup> Material No. is defined by the factory!

Item	Qty.	Unit description	Type code	Material No.
.0	1	Manifold block assembly	2HSR 06 C2X/115B234...	<sup>1)</sup>
.01	1	Manifold block	PLATTE 2HSR 06-25/01C	R900172220
.11	1	Directional valve	4WE 6 J6X/EG24N9K4	R900561288
.12	1	Pressure reducing valve	ZDR 6 DA2-4X/150Y	R900410849
.13	1	Double check valve	Z2S 6 -2-6X/	R900347496
.14	1	Double throttle check valve	Z2FS 6 -2-4X/2QV	R900481624
.15	1	Check valve	Z1S 6 T1-3X/V	R900417569
	4	Stud	M5 x 210-10.9 DIN 939	R900012018
	4	Hexagon nut	M5-A3C RN 145.15-C45	R900009433
.23	1	Directional valve	4WE 6 J6X/EG24N9K4	R900561288
.24	1	Double check valve	Z2S 6 -2-6X/	R900347496
.25	1	Double throttle check valve	Z2S 6 -2-4X/2QV	R900481624
	4	S.H.C.S.	M5 x 130-10.9 DIN 912	R900014920

**Unit dimensions: actuator ports on side „C“ – Component series 2X** (Dimensions in mm)

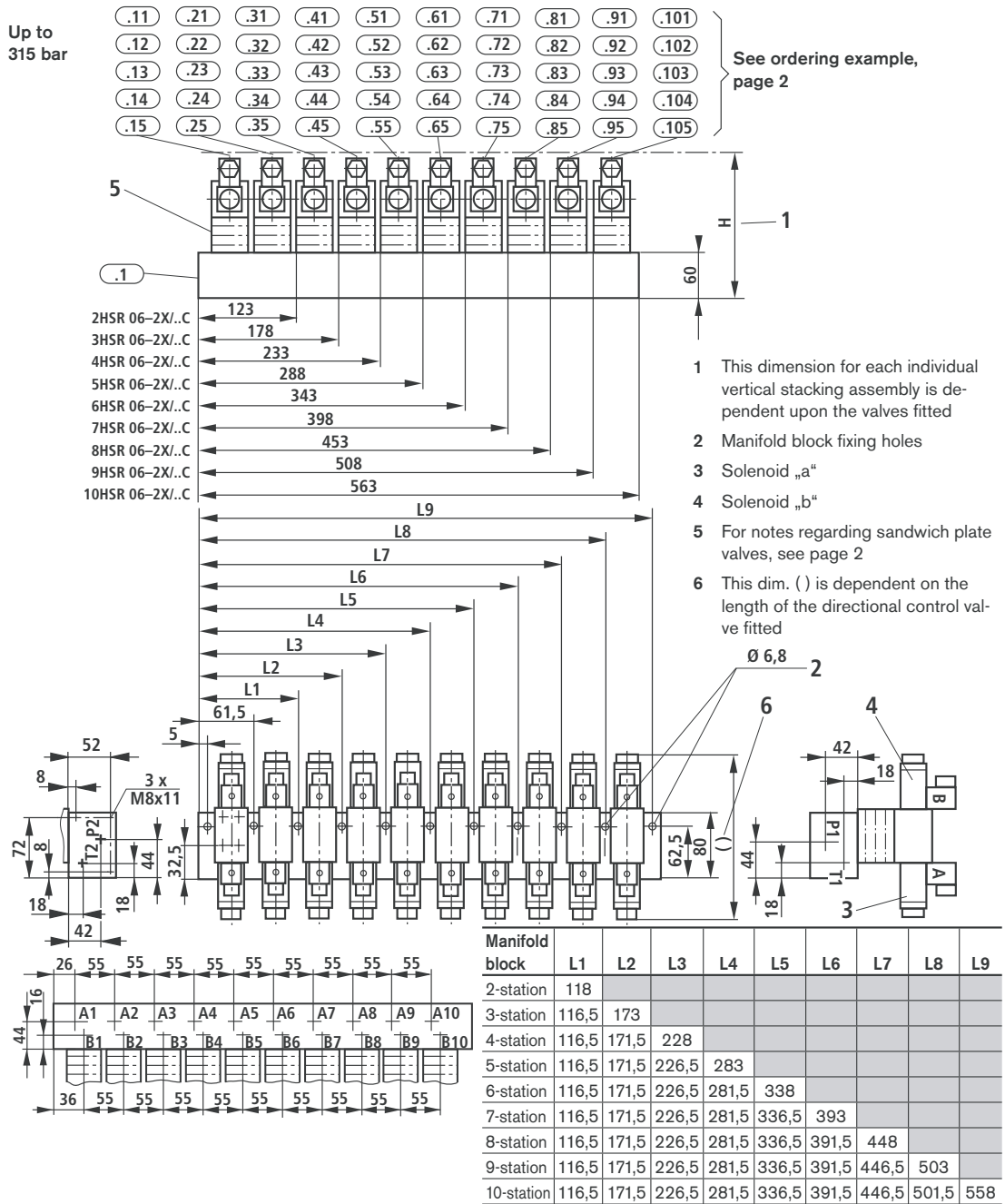

Thread type	Pipe threads to ISO 228 part 1		Metric ISO threads to DIN 3852 part 1		NPT threads	
Port	A1..A10; B1..B10	P1, P2, T1, T2	A1..A10; B1..B10	P1, P2, T1, T2	A1..A10; B1..B10	P1, P2, T1, T2
Thread Ø	G 3/8	G 1/2	M16 x 1,5	M18 x 1,5	3/8" NPT	1/2" NPT
Thread depth	12	14	12	12	17,5	23
Spot face Ø	28	34	28	28	-	-
Spot face depth	1	1	1	1	-	-



**Unit dimensions: actuator ports on underside „D“ – Component series 2X (Dimensions in mm)**

Up to 315 bar

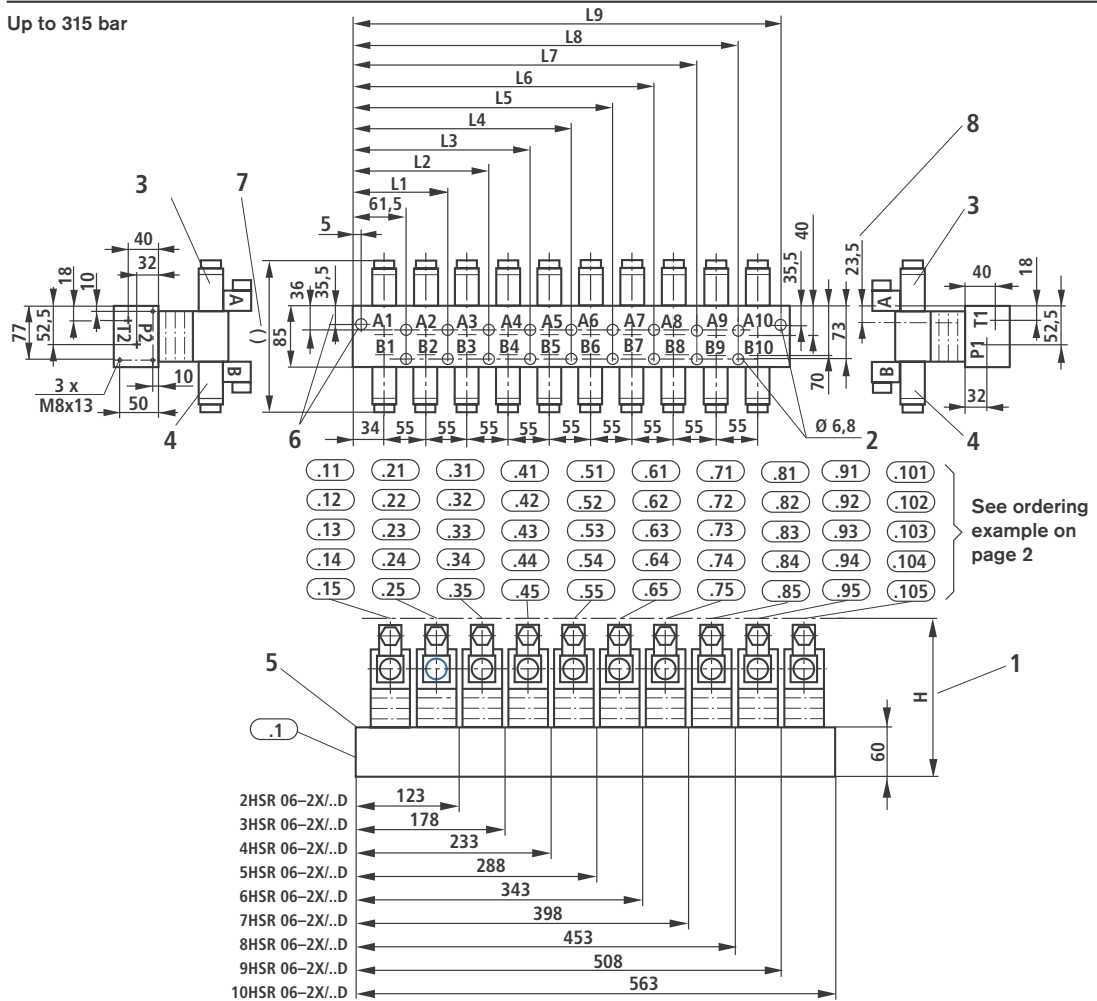

- This dimension for each individual vertical stacking assembly is dependent upon the valves fitted
- Manifold block fixing holes
- Solenoid „a“
- Solenoid „b“
- For notes regarding sandwich plate valves, see page 2
- 1 external hole for each manifold block; dimensions for external holes
- This dim. ( ) is dependent on the length of directional control valve fitted
- Distance of valve porting pattern to the edge of the manifold

Thread type	Pipe thread to ISO 228 part 1		Metric ISO threads to DIN 3852 part 1		NPT thread	
	A1..A10; B1..B10	P1, P2, T1, T2	A1..A10; B1..B10	P1, P2, T1, T2	A1..A10; B1..B10	P1, P2, T1, T2
Port	A1..A10; B1..B10	P1, P2, T1, T2	A1..A10; B1..B10	P1, P2, T1, T2	A1..A10; B1..B10	P1, P2, T1, T2
Thread Ø	G 3/8	G 1/2	M16 x 1,5	M18 x 1,5	3/8" NPT	1/2" NPT
Thread depth	12	14	12	12	17,5	23
Spot face Ø	28	34	28	28	-	-
Spot face depth	1	1	1	1	-	-

**Unit dimensions: actuator ports on underside „D“ – Component series 3X (Dimensions in mm)**

Up to 315 bar,  
with enlarged con-  
nection threads

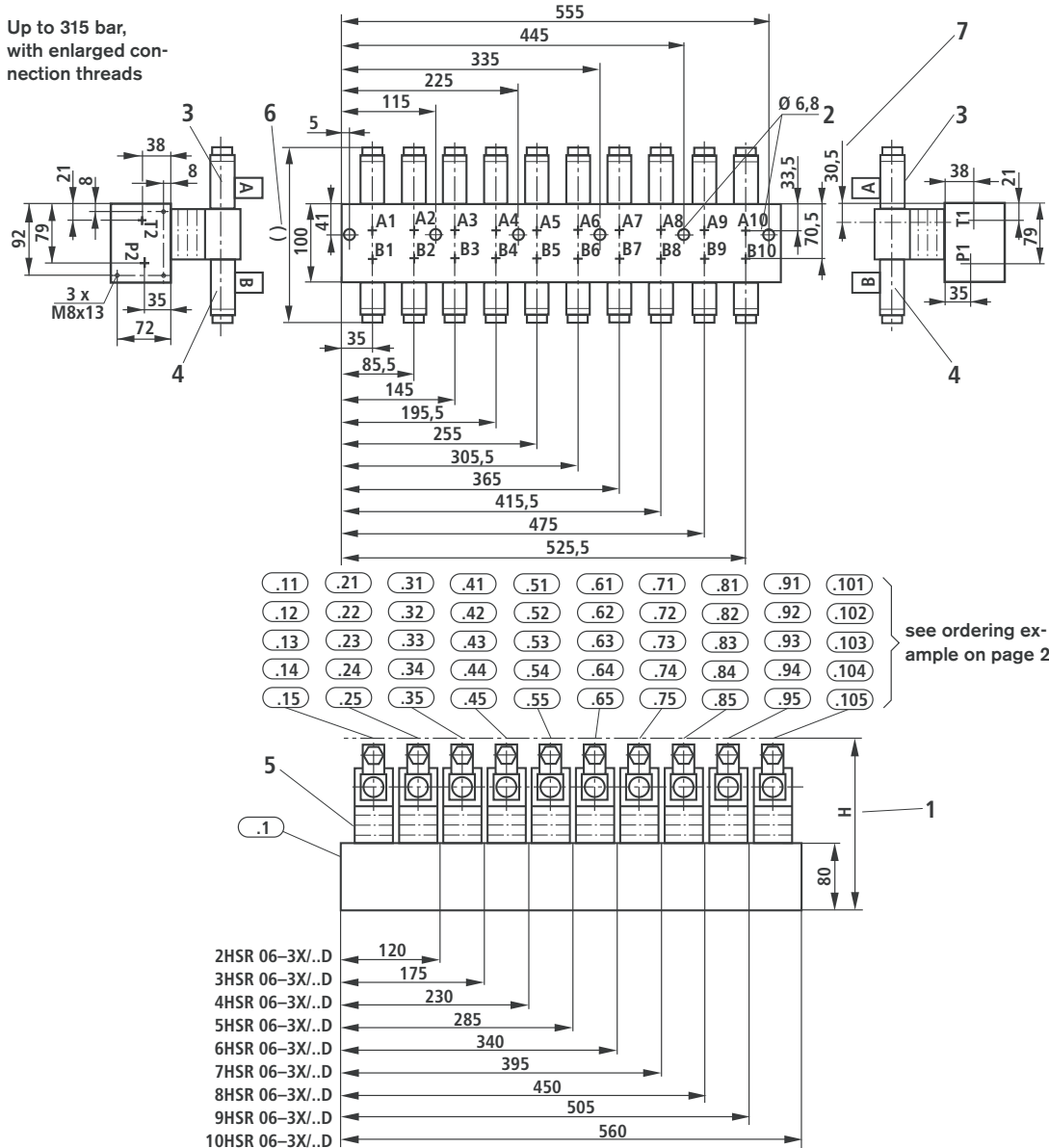

see ordering ex-  
ample on page 2

- 1 This dimension for each individual vertical stacking assembly is dependent upon the valves fitted
- 2 Manifold block fixing holes
- 3 Solenoid „a“
- 4 Solenoid „b“

- 5 For notes regarding sandwich plate valves, see page 2
- 6 This dim. ( ) is dependent on the length of directional control valve fitted
- 7 Distance of valve porting pattern to the edge of the manifold

Thread type	Pipe thread to ISO 228 part 1		Metric ISO threads to DIN 3852 part 1		NPT threads	
	A1..A10; B1..B10	P1, P2, T1, T2	A1..A10; B1..B10	P1, P2, T1, T2	A1..A10; B1..B10	P1, P2, T1, T2
Port	A1..A10; B1..B10	P1, P2, T1, T2	A1..A10; B1..B10	P1, P2, T1, T2	A1..A10; B1..B10	P1, P2, T1, T2
Thread Ø	G 1/2	G 3/4	M22 x 1,5	M27 x 2	1/2" NPT	3/4" NPT
Thread depth	14	16	14	16	23	23
Spot face Ø	34	42	34	42	-	-
Spot face depth	1	1	1	1	-	-

## Fixing screws and permissible operating pressure in relation to the valves fitted

Selection table for vertical stacking assembly in conjunction with directional valve WE 6 (also see page 81), Cl = clamping length

Pressure reducing valve (Cl = 40 mm)	Pressure relief valve (Cl = 40 mm)	Double check valve (Cl = 40 mm)	Check valve (Cl = 40 mm)	Double throttle check valve (Cl = 40 mm)	Pres. switch with sandwich plate (Cl = 40 mm)	S.H.C.S. DIN 912 Studs DIN 939 M <sub>A</sub> = 9 Nm	Tensile strength	Material No.	Operat. pres. P <sub>max</sub> in bar
ZDR 6 D...-4X/...						M5 x 90 ISO 4762	10.9	R913000222	315
	Z.DB 6 V...-4X/...					M5 x 90 ISO 4762	10.9	R913000222	315
		Z2S 6 ..-6X/...				M5 x 90 ISO 4762	10.9	R913000222	315
			Z1S 6 ...- /...			M5 x 90 ISO 4762	10.9	R913000222	315
				Z2FS 6-4X/V		M5 x 90 ISO 4762	10.9	R913000222	315
					HED 8 OH1X/..	M5 x 90 ISO 4762	10.9	R913000222	315
ZDR 6 D...-4X/...	Z.DB 6 V...-4X/...					M5 x 130 DIN 912	10.9	R900014920	315
ZDR 6 D...-4X/...		Z2S 6 ..-6X/...				M5 x 130 DIN 912	10.9	R900014920	315
ZDR 6 D...-4X/...			Z1S 6 ...- /...			M5 x 130 DIN 912	10.9	R900014920	315
ZDR 6 D...-4X/...				Z2FS 6-4X/V		M5 x 130 DIN 912	10.9	R900014920	315
ZDR 6 D...-4X/...					HED 8 OH1X/..	M5 x 130 DIN 912	10.9	R900014920	315
	Z.DB 6 V...-4X/...	Z2S 6 ..-6X/...				M5 x 130 DIN 912	10.9	R900014920	315
	Z.DB 6 V...-4X/...		Z1S 6 ...- /...			M5 x 130 DIN 912	10.9	R900014920	315
	Z.DB 6 V...-4X/...			Z2FS 6-4X/V		M5 x 130 DIN 912	10.9	R900014920	315
	Z.DB 6 V...-4X/...				HED 8 OH1X/..	M5 x 130 DIN 912	10.9	R900014920	315
		Z2S 6 ..-6X/...	Z1S 6 ...- /...			M5 x 130 DIN 912	10.9	R900014920	315
		Z2S 6 ..-6X/...		Z2FS 6-4X/V		M5 x 130 DIN 912	10.9	R900014920	315
		Z2S 6 ..-6X/...			HED 8 OH1X/..	M5 x 130 DIN 912	10.9	R900014920	315
			Z1S 6 ...- /...	Z2FS 6-4X/V		M5 x 130 DIN 912	10.9	R900014920	315
			Z1S 6 ...- /...		HED 8 OH1X/..	M5 x 130 DIN 912	10.9	R900014920	315
				Z2FS 6-4X/V	HED 8 OH1X/..	M5 x 130 DIN 912	10.9	R900014920	315
ZDR 6 D...-4X/...	Z.DB 6 V...-4X/...	Z2S 6 ..-6X/...				M5 x 170 DIN 939	10.9	R900230414	315
ZDR 6 D...-4X/...	Z.DB 6 V...-4X/...		Z1S 6 ...- /...			M5 x 170 DIN 939	10.9	R900230414	315
ZDR 6 D...-4X/...	Z.DB 6 V...-4X/...			Z2FS 6-4X/V		M5 x 170 DIN 939	10.9	R900230414	315
ZDR 6 D...-4X/...	Z.DB 6 V...-4X/...				HED 8 OH1X/..	M5 x 170 DIN 939	10.9	R900230414	315
ZDR 6 D...-4X/...		Z2S 6 ..-6X/...	Z1S 6 ...- /...			M5 x 170 DIN 939	10.9	R900230414	315
ZDR 6 D...-4X/...		Z2S 6 ..-6X/...		Z2FS 6-4X/V		M5 x 170 DIN 939	10.9	R900230414	315
ZDR 6 D...-4X/...		Z2S 6 ..-6X/...			HED 8 OH1X/..	M5 x 170 DIN 939	10.9	R900230414	315
ZDR 6 D...-4X/...			Z1S 6 ...- /...	Z2FS 6-4X/V		M5 x 170 DIN 939	10.9	R900230414	315
ZDR 6 D...-4X/...			Z1S 6 ...- /...		HED 8 OH1X/..	M5 x 170 DIN 939	10.9	R900230414	315
ZDR 6 D...-4X/...				Z2FS 6-4X/V	HED 8 OH1X/..	M5 x 170 DIN 939	10.9	R900230414	315
	Z.DB 6 V...-4X/...	Z2S 6 ..-6X/...	Z1S 6 ...- /...			M5 x 170 DIN 939	10.9	R900230414	315
	Z.DB 6 V...-4X/...	Z2S 6 ..-6X/...		Z2FS 6-4X/V		M5 x 170 DIN 939	10.9	R900230414	315
	Z.DB 6 V...-4X/...	Z2S 6 ..-6X/...			HED 8 OH1X/..	M5 x 170 DIN 939	10.9	R900230414	315
	Z.DB 6 V...-4X/...		Z1S 6 ...- /...	Z2FS 6-4X/V		M5 x 170 DIN 939	10.9	R900230414	315
	Z.DB 6 V...-4X/...		Z1S 6 ...- /...		HED 8 OH1X/..	M5 x 170 DIN 939	10.9	R900230414	315
		Z2S 6 ..-6X/...	Z1S 6 ...- /...	Z2FS 6-4X/V		M5 x 170 DIN 939	10.9	R900230414	315
		Z2S 6 ..-6X/...			HED 8 OH1X/..	M5 x 170 DIN 939	10.9	R900230414	315
			Z1S 6 ...- /...	Z2FS 6-4X/V	HED 8 OH1X/..	M5 x 170 DIN 939	10.9	R900230414	315
ZDR 6 D...-4X/...	Z.DB 6 V...-4X/...	Z2S 6 ..-6X/...	Z1S 6 ...- /...			M5 x 210 DIN 939	10.9	R900012018	250
ZDR 6 D...-4X/...	Z.DB 6 V...-4X/...	Z2S 6 ..-6X/...		Z2FS 6-4X/V		M5 x 210 DIN 939	10.9	R900012018	250
ZDR 6 D...-4X/...	Z.DB 6 V...-4X/...	Z2S 6 ..-6X/...			HED 8 OH1X/..	M5 x 210 DIN 939	10.9	R900012018	250
	Z.DB 6 V...-4X/...	Z2S 6 ..-6X/...	Z1S 6 ...- /...	Z2FS 6-4X/V		M5 x 210 DIN 939	10.9	R900012018	250
	Z.DB 6 V...-4X/...	Z2S 6 ..-6X/...	Z1S 6 ...- /...		HED 8 OH1X/..	M5 x 210 DIN 939	10.9	R900012018	250
		Z2S 6 ..-6X/...	Z1S 6 ...- /...	Z2FS 6-4X/V	HED 8 OH1X/..	M5 x 210 DIN 939	10.9	R900012018	250
ZDR 6 D...-4X/...	Z.DB 6 V...-4X/...	Z2S 6 ..-6X/...	Z1S 6 ...- /...	Z2FS 6-4X/V		M5 x 250 DIN 939	10.9	R900012020	210
ZDR 6 D...-4X/...		Z2S 6 ..-6X/...	Z1S 6 ...- /...	Z2FS 6-4X/V	HED 8 OH1X/..	M5 x 250 DIN 939	10.9	R900012020	210
ZDR 6 D...-4X/...	Z.DB 6 V...-4X/...		Z1S 6 ...- /...	Z2FS 6-4X/V	HED 8 OH1X/..	M5 x 250 DIN 939	10.9	R900012020	210
ZDR 6 D...-4X/...	Z.DB 6 V...-4X/...	Z2S 6 ..-6X/...		Z2FS 6-4X/V	HED 8 OH1X/..	M5 x 250 DIN 939	10.9	R900012020	210
ZDR 6 D...-4X/...	Z.DB 6 V...-4X/...	Z2S 6 ..-6X/...	Z1S 6 ...- /...		HED 8 OH1X/..	M5 x 250 DIN 939	10.9	R900012020	210
	Z.DB 6 V...-4X/...	Z2S 6 ..-6X/...	Z1S 6 ...- /...	Z2FS 6-4X/V	HED 8 OH1X/..	M5 x 250 DIN 939	10.9	R900012020	210
Directional control valve		WE 6-6X + multi-station manifold block HSR 06				M5 x 50 ISO 4762	10.9	R913000064	315
Proportional valve		WR.6 + multi-station manifold block HSR 06				M5 x 40 ISO 4762	10.9	R913000139	315

## Fixing screws and permissible operating pressure in relation to the valves fitted

### Notes:

- The screw selection table shown on page 7 is not valid for directional valves protected against sea water, because these directional valves have different clamping lengths (for dimensions see catalogue sheets on sea water protected directional valves)

- Directional valves with central connections „D“, „DL“, „DZ“ and „DZL“ can only be used with S.H.C.S. or studs and nuts RN 115.43-C45V, Material No. R900176106.

### Nut M5 DIN 939, tensile class 10.9

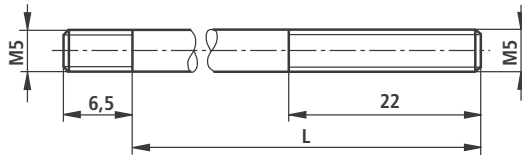

### Nut M5 A3C RN 115.43-C45V, Material No. R900176106

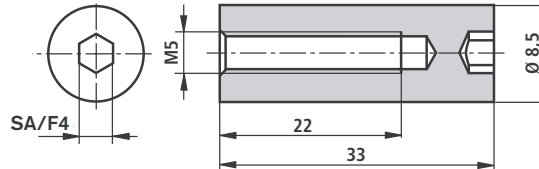

L see screw selection table

### Hexagon nut M5-A3C RN 145.15-C45 Material No. R900009433

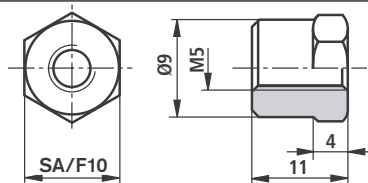

## Engineering guidelines

### Pressure reducing valve combined with a double check valve

The pressure reducing valve ZDR..DA (with pressure reduction in port A) **must** always be fitted between the directional valve and the double check valve Z2S.. . Leak-free closure of the system cannot otherwise be ensured.

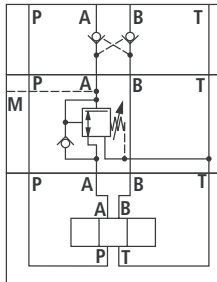

### Pressure relief valve combined with a double check valve

Leak-free closure of the actuator is **not** possible, if a pressure relief valve type ZDB../Z2DB.. effective in port A and/or B is used with a double check valve.

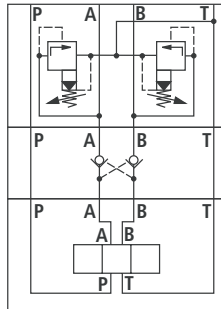

The installation of sandwich plates with 2 pressure switches with manifold blocks with actuator ports on side „C“ is **not possible**.

### Pressure switches combined with a double throttle check valve

#### Meter-in control

The pressure switch HED 8 OH, effective in port A and/or B, is fitted between the subplate and the double throttle check valve Z2FS.

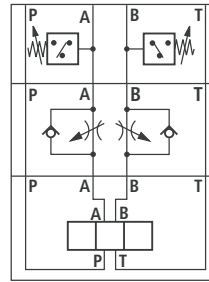

#### Meter-out control

The pressure switch HED 8 OH, effective in port A and/or B, is fitted between the directional valve and the double throttle check valve Z2FS.

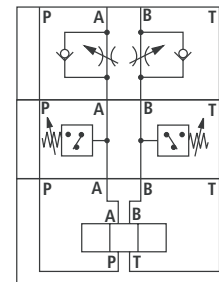

The circuits shown are only examples.

These engineering design guidelines also apply to valves of similar design and function.

© This document, as well as the data, specifications and other information set forth in it, are the exclusive property of Bosch Rexroth AG. Without their consent it may not be reproduced or given to third parties.

The data specified above only serve to describe the product. No statements concerning a certain condition or suitability for a certain application can be derived from our information. The information given does not release the user from the obligation of own judgment and verification. It must be remembered that our products are subject to a natural process of wear and aging.