

Electric Drives
and Controls

Hydraulics

Linear Motion and
Assembly Technologies

Pneumatics

Service

Rexroth
Bosch Group

Throttle check valve

RE 27526/04.08
Replaces: 11.02

1/8

Type Z2FS

Size 16
Component series 3X
Maximum operating pressure 350 bar [5076 psi]
Maximum flow 250 l/min [66 US gpm]

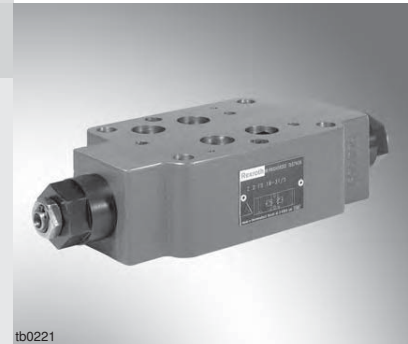

tb0221

Table of contents

Content

Features
Ordering code
Symbols
Function, section
Technical data
Characteristic curves
Unit dimensions

Page

– Sandwich plate valve
1 – Porting pattern to ISO 4401-07-07-0-05 and
NFFPA T3.5.1 R2-D07
2 – For limiting the flow in 2 actuator ports
3 – Adjustment element: Spindle with hexagon socket
4 – For meter-in or meter-out throttling
5
6

Features

Ordering code

Z2FS 16 8 -3X/ *

Throttle check valve,
sandwich plate design

Size 16

= 16

Throttle check valve Side A and B

= -

Throttle check valve Side A

= A

Throttle check valve Side B

= B

Adjustment element

Spindle with hexagon socket

= 8

Component series 30 to 39

= 3X

(30 to 39: unchanged installation and connection dimensions)

Further details in clear text

Seal material

No code =

NBR seals

V =

FKM seals

(other seals on request)

⚠ Attention!

Observe compatibility of seals with hydraulic fluid used

S = (...A8-3X/S) meter-in throttling on side A

(...B8-3X/S) meter-in throttling on side B

(...-8-3X/S) meter-in throttling on sides A and B

S2 = (...A8-3X/S2) meter-out throttling on side A

(...B8-3X/S2) meter-out throttling on side B

(...-8-3X/S2) meter-out throttling on sides A and B

Standard types and components are given
in the EPS (standard price list).

Symbols (① = component side, ② = plate side)

Meter-in throttling "S"

Meter-out throttling "S2"

Variant "S"

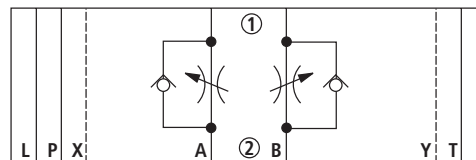
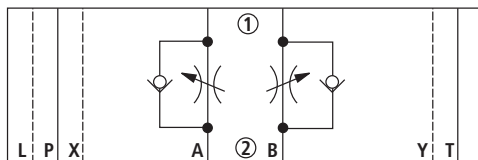

Variant "A"

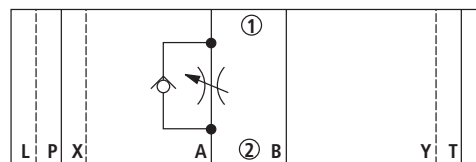
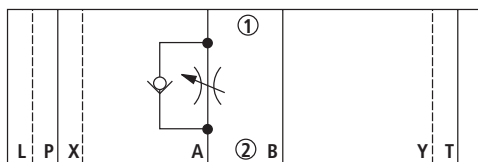

Variant "B"

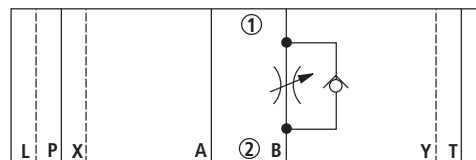
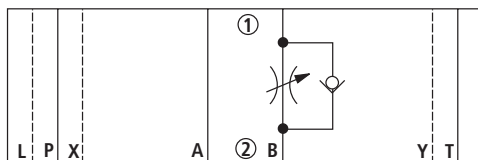

Function, section

Valves of type Z2FS are throttle check valves of sandwich plate design. They are used to limit the flow in one or two actuator ports.

Two throttle check valves, which are arranged symmetrically to each other, limit flows (through adjustable throttle spools) in one direction and allow free return flow in the opposite direction.

In the case of meter-in throttling the hydraulic fluid is fed through channel A1 via throttling point (1) to actuator A2. The throttle spool (2.1) can be axially adjusted by means of spindle (3), thus allowing throttling point (1) to be adjusted.

At the same time, the hydraulic fluid present in channel A1 gets via bore (4) to spool side (5). Together with the spring force, the applied pressure holds the throttle spool (2.1) in the throttling position.

The hydraulic fluid returning from actuator B2 shifts throttle spool (2.2). The valve then acts as check valve with free flow. Depending on the variant ("S" or "S2") throttling can be effective in the inflow or outflow.

Flow limitation

To change the velocity of an actuator, the throttle check valve is to be installed between the directional valve and the sub-plate.

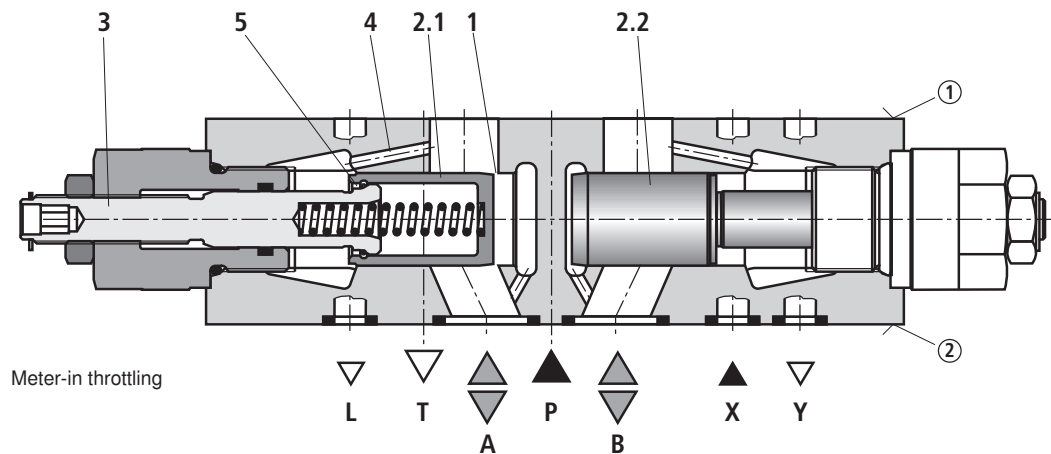

① = component side

② = plate side

Technical data (for applications outside these parameters, please consult us!)

General

Weight	kg [lbs]	ca. 4.7 [10.4]
Installation orientation		Optional
Ambient temperature range	°C [°F]	-30 to +80 [-22 to +176] (NBR seals) -20 to +80 [-4 to +176] (FKM seals)

Hydraulic

Maximum operating pressure	bar [psi]	350 [5076]
Maximum flow	l/min [US gpm]	250 [66]
Hydraulic fluid		Mineral oil (HL, HLP) to DIN 51524 ¹⁾ ; fast bio-degradable hydraulic fluids to VDMA 24568 (see also RE 90221); HETG (rape seed oil) ¹⁾ ; HEPG (polyglycols) ²⁾ ; HEES (synthetic esters) ²⁾ ; other hydraulic fluids on request
Hydraulic fluid temperature range	°C [°F]	-30 to +80 [-22 to +176] (NBR seals) -20 to +80 [-4 to +176] (FKM seals)
Viscosity range	mm ² /s [SUS]	2.8 to 380 [13 to 1760]
Permissible max. degree of contamination of the hydraulic fluid - cleanliness class to ISO 4406 (c)		Class 20/18/15 ³⁾

¹⁾ Suitable for NBR and FKM seals

²⁾ Suitable only for FKM seals

³⁾ The cleanliness classes specified for components must be adhered to in hydraulic systems. Effective filtration prevents malfunction and, at the same time, prolongs the service life of components.

For the selection of filters, see data sheets RE 50070, RE 50076, RE 50081, RE 50086, RE 50087 and RE 50088.

Characteristic curves (measured with HLP46, $\vartheta_{oil} (\nu = 190 \text{ SUS}) = 40 \text{ }^\circ\text{C} \pm 5 \text{ }^\circ\text{C} [104 \text{ }^\circ\text{F} \pm 9 \text{ }^\circ\text{F}]$)

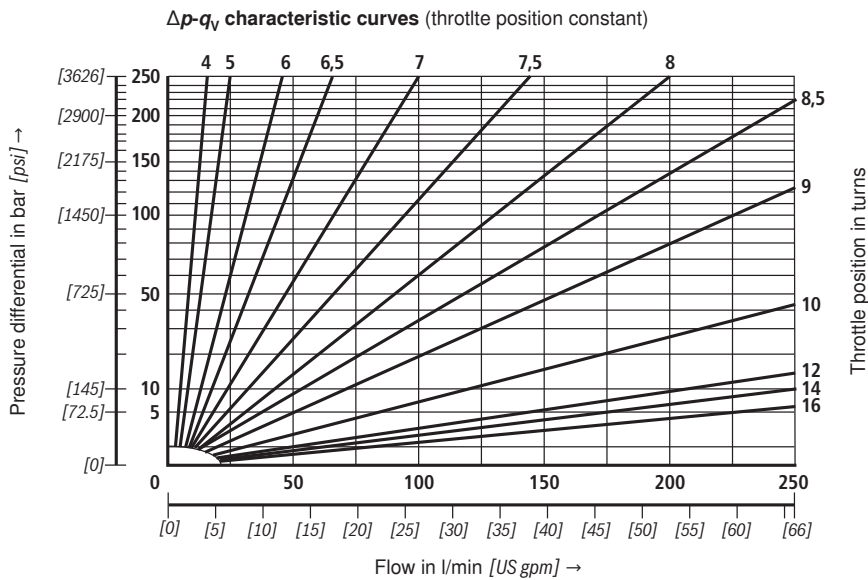
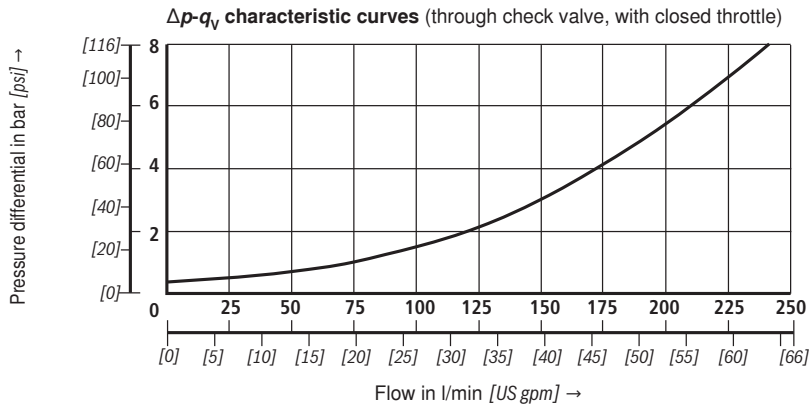

Unit dimensions (dimensions in mm [inch])

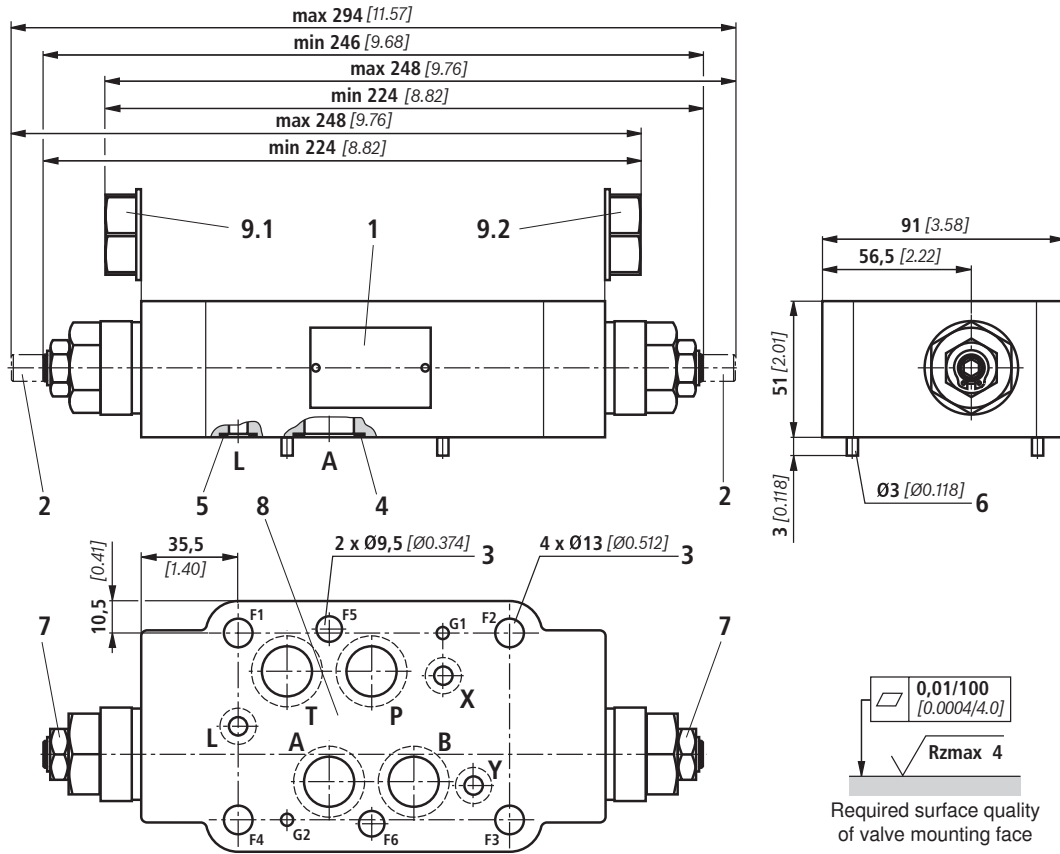

- 1 Nameplate
- 2 Type of adjustment "8"
Spindle for adjusting the flow cross-section (hexagon socket 6 A/F)
 - Turning counter-clockwise = larger flow
 - Turning clockwise = smaller flow
- 3 Through-bores for valve mounting
- 4 Identical seal rings for ports A, B, P, T
- 5 Identical seal rings for ports X, Y, L
- 6 Locating pin (included in the scope of supply)
- 7 Hexagon 19 A/F, tightening torque $M_T = 25 \text{ Nm}$ [18.4 ft-lbs]
- 8 Porting pattern to ISO 4401-07-07-0-05 and NFPA T3.5.1 R2-D07
- 9.1 Plug screw on variant "B"
- 9.2 Plug screw on variant "A"

Valve mounting screws (separate order)

- Metric
 - 4 hexagon socket head cap screws ISO 4762 - M10 - 10.9-fIZn-240h-L
 - 2 hexagon socket head cap screws ISO 4762 - M6 - 10.9-fIZn-240h-L
- UNC
 - 4 hexagon socket head cap screws 3/8-16 UNC
 - 2 hexagon socket head cap screws 1/4-20 UNC

Note!

The length and tightening torque of valve mounting screws must be calculated taking account of the components mounted above and below the sandwich plate valve.

Notes

© This document, as well as the data, specifications and other information set forth in it, are the exclusive property of Bosch Rexroth AG. It may not be reproduced or given to third parties without its consent. The data specified above only serve to describe the product. No statements concerning a certain condition or suitability for a certain application can be derived from our information. The information given does not release the user from the obligation of own judgment and verification. It must be remembered that our products are subject to a natural process of wear and aging.