

NG6 Filter



Description

This filter provides protection for NG6 block systems up to 200 bar. It can be mounted directly on the NG6 block offering a very compact assembly. A mechanical clogging indicator is fitted as standard with the electrical version supplied as an optional extra. The standard element filter is 20 micron.

Operating temperatures: 0°C to 100°C

Dimensions

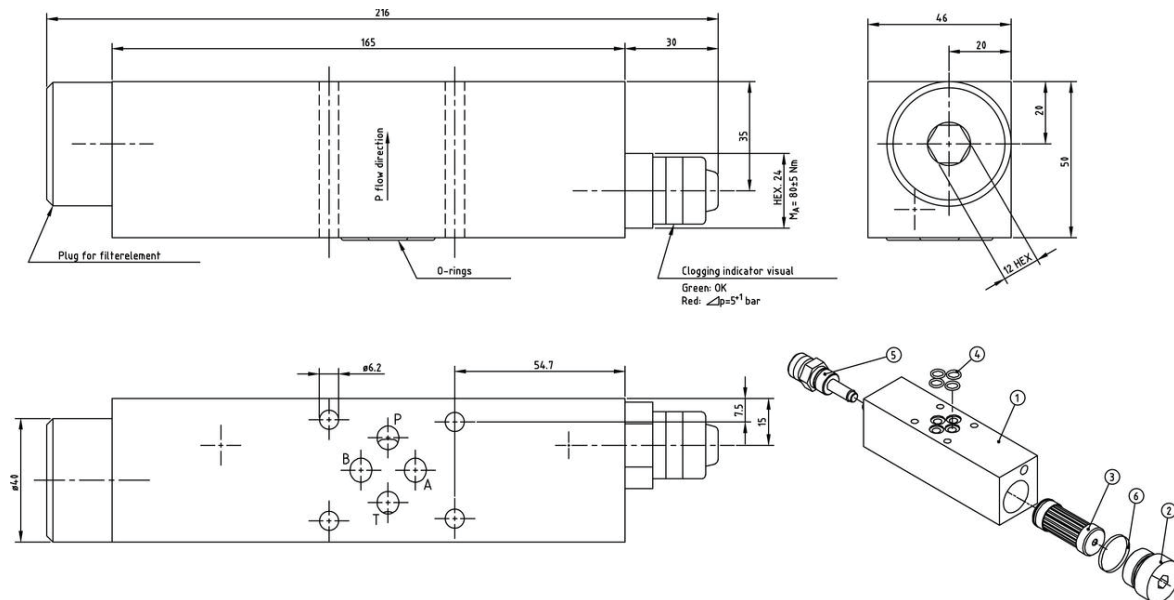

3-132

Function diagram

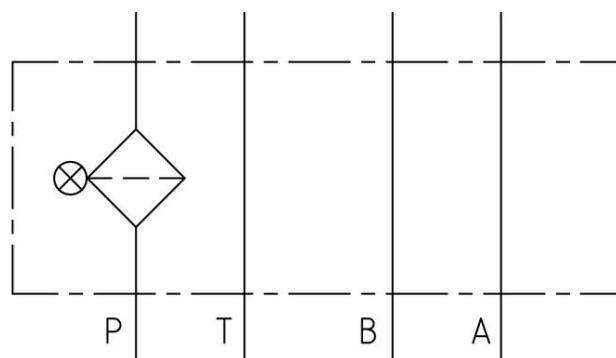

0-233 Model

Ordering

Order no.	Product	In / Out	Overall length	W x D	Weight	Max. pressure
FIL- NG6-10	NG6 filter	NG6 (DO3)	209 mm	50 x 46 mm	2.3 kg	200 bar
FIL- KITNG6-10	Filter element (Spare Part)	-	-	-	-	-
FIL- NG6- CI	Clogging indicator, Mechanical (Spare Part)	-	-	-	-	-
FIL- NG6- CIE	Clogging indicator Electrical (Optional)	-	-	-	-	-