

The Drive & Control Company

**Rexroth**  
Bosch Group

Valve amplifier for proportional directional valves and proportional pressure valves, additional information

Type VT-VSPA2-1-2X/V0/T1, .../T5

**RE 30110-Z**

Edition: 2013-09

Replaces: 05.13

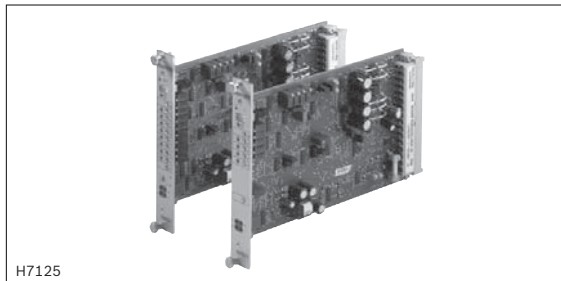

Information regarding the conversion of different amplifiers to amplifiers type VT-VSPA2-1-2X/V0/T1, material number R901002090 and amplifier type VT-VSPA2-1-2X/V0/T5, material number R901002095

Considering the prerequisites mentioned in this additional information, the analog amplifiers type VT-VSPA2-1-2X/V0/T1 and VT-VSPA2-1-2X/V0/T5 can be used as replacement for the following amplifier modules:

VT-VSPA2-1-2X/V0/T1 as replacement for:

- ▶ VT 3000-3X
- ▶ VT 3013-3X
- ▶ VT 3014-3X
- ▶ VT 3026-3X
- ▶ VT-VSPA2-1-1X/T1
- ▶ VT-VSPA2-50-1X/T1

VT-VSPA2-1-2X/V0/T5 as replacement for:

- ▶ VT 3006-3X
- ▶ VT 3017-3X
- ▶ VT 3018-3X
- ▶ VT-VSPA2-1-1X/T5
- ▶ VT-VSPA2-50-1X/T5

You must imperatively comply with the order of the work steps specified in this additional information!

#### Notices:

Assembly of the product requires basic electrical knowledge:

- ▶ The product may only be re-wired and assembled by qualified personnel.
- ▶ De-energize the amplifier before any work!

#### Contents

Configurations for VT-VSPA2-1-2X/V0/...	2
Position of jumpers and adjustment elements	3
Modification work	4
Block diagram/pin assignment VT 3000, VT 3013, VT 3014, VT 3026	5
Block diagram/pin assignment VT 3006, VT 3017, VT 3018	6
Block diagram/pin assignment VT-VSPA2-1-1X/T1	7
Block diagram/pin assignment VT-VSPA2-1-1X/T5	8
Block diagram/pin assignment VT-VSPA2-50-1X/T1	9
Block diagram/pin assignment VT-VSPA2-50-1X/T5	10
Commissioning	11

2/12 VT-VSPA2-1-2X/V0/T1, .../T5 | Valve amplifier

## Configurations for VT-VSPA2-1-2X/V0/...

	Factory setting VT-VSPA2-1-2X/V0/...		VT 3026 <sup>1)</sup> (RE 30093) Observe footnote 1)!	VT 3000 <sup>1)</sup> (RE 29935) VT 3006 <sup>1)</sup> (RE 29926) Observe footnote 1)!	VT 3013 (RE 29937) VT 3017 (RE 29939)	VT 3014 (RE 29937) VT 3018 (RE 29939)	VT-VSPA2-1-1X/T1 VT-VSPA2-1-1X/T5 (RE 30112)	VT-VSPA2-50-1X/T1 VT-VSPA2-50-1X/T5 (RE 30113)
		Configuration for:	A4VG...EP2	.WRZ (to component series 6X) DBEP6, 3DREP6 (in each case component series 1X)	4WR6	4WRA10	4WR6 (from compo- nent series 2X)	3DREP6 (from component series 2X), .WRZ (from component series 7X)
Inversion J1	Non-inverting Jumper open		Jumper open	Jumper open	Jumper open	Jumper open	Jumper open	Jumper open
Ramp function J2	Ramp on Jumper open		Jumper open	Jumper open	Jumper open	Jumper open	Jumper open	Jumper open
Ramp time J3	30 ms to 5 s Jumper open		Jumper open	Jumper open	Jumper open	Jumper open	Jumper open	Jumper open
Step function J4	Step function on Jumper open		Jumper open	Jumper open	Jumper open	Jumper open	Jumper open	Jumper open
Clock frequency J5, J6 closed	170 Hz	Setting by means of potentiometer f	100 Hz ±10% <sup>2)</sup>	170 Hz ±10%	190 Hz ±10% <sup>2)</sup>	Jumper 6 open 100 Hz ±10% <sup>2)</sup>	300 Hz ±10% <sup>2)</sup>	220 Hz ±10% <sup>2)</sup>
Maximum current setting J7 closed	1500 mA	Setting by means of Gw+ and Gw-	600 mA <sup>2)</sup>	800 mA <sup>2)</sup>	1500 mA	1500 mA	2500 mA <sup>2)</sup>	1500 mA
Step level J8, J9 closed	500 mA	Setting by means of S+ and S-	200 mA <sup>2)</sup>	200 mA <sup>2)</sup>	500 mA	500 mA	350 mA <sup>2)</sup>	500 mA

Bosch Rexroth AG, RE 30110-Z, edition: 2013-09

Table 1: Configurations VT-VSPA2-1-2X/V0/T1 and T5

<sup>1)</sup> When using the amplifiers VT-VSPA2-1-2X/V0/... as replacement for the amplifier types VT 3000, VT 3006 and VT 3026, the supply voltage must lie between 28 and 30 VDC!

<sup>2)</sup> These values must be set!

In all measurements, you must measure from the measuring socket "I" against "M0"!  
For more information (characteristic curves, etc. ...) refer to the data sheets specified above.

Please note:

The order of the following steps must imperatively be observed!

## Position of jumpers and adjustment elements

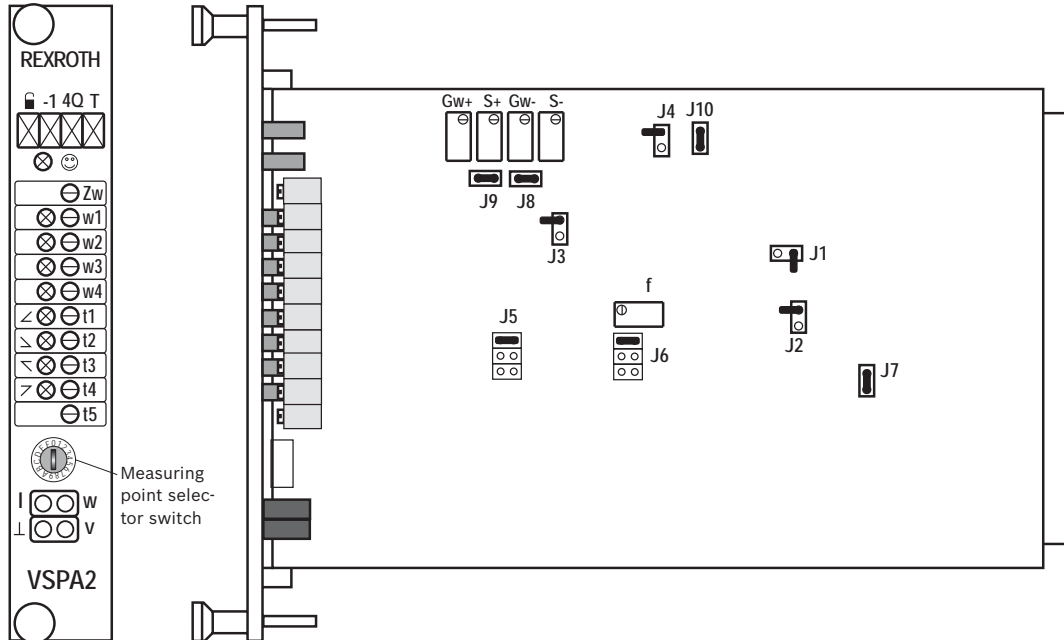

4/12 VT-VSPA2-1-2X/V0/T1, .../T5 | Valve amplifier

## Modification work

- ▶ VT-VSPA2-1-2X/V0/T1 serves as replacement for:
  - VT 3000, VT 3013, VT 3014, VT 3026,  
VT-VSPA2-1-1X/T1, VT-VSPA2-50-1X/T1
- ▶ VT-VSPA2-1-2X/V0/T5 serves as replacement for:
  - VT 3006, VT 3017, VT 3018, VT-VSPA2-1-1X/T5,  
VT-VSPA2-50-1X/T5

The following modification work must be made before the exact adjustment of the VT-VSPA2-1-2X/V0/T1 or T5:

- ▶ Card holder replacement:
 

When replacing one of the amplifiers listed on the left by the amplifiers VT-VSPA2-1-2X/V0/T1 and T5, the existing card holder with the DIN female multipoint connector VT 3002-1-2X/32D must be additionally replaced by a card holder with the female multipoint connector **VT 3002-1-2X/48F**.
- ▶ Carry out the re-wiring according to the following table.

## Re-wiring table

Terminal	VT30...	VT-VSPA2...1X		VT-VSPA2-1-2X/V0/T1 Terminal	VT-VSPA2-1-2X/V0/T5 Terminal
2a	Output switch-over $\pm 9$ V			Not available <sup>1)</sup>	Not available <sup>1)</sup>
2c	–	Ready for operation	→	d22	d22
4a	Call-up command value/ramp 2		→	d4	d4 and d12
4c	Call-up switch-over $\pm 9$ V			Not available <sup>1)</sup>	Not available <sup>1)</sup>
6a	Call-up command value/ramp 3		→	d6	d6 and d14
6c	Call-up command value/ramp 4		→	d8	d8 and d16
8a	Input command value 3		→	b6	b6
8c	Call-up command value/ramp 1		→	d2	d2 and d10
10a	Input command value 2		→	b4	b4
10c	Input command value 1		→	b2	b2
12a	Input command value 4		→	b8	b8
12c	Input command value 5			Not available <sup>1)</sup>	Not available <sup>1)</sup>
14a	Ramp external		→	d28	d28
14c	Ramp external		→	d24	d24
16a	Differential input		→	b14	b14
16c	Differential input		→	b16	b16
18a	Command value output		→	d30	d30
18c	Call-up ramp off		→	b12	b12
20a	Measurement zero		→	b28	b28
20c	+9 V output		→	b32	b32
22a	Pin 1 solenoid B		→	z6	z6
24a	Pin 1 solenoid A		→	z2	z2
26a	0 V input voltage		→	z32	z32
26c	Output –9 V		→	b30	b30
28a	Pin 2 solenoid B		→	z8	z8
28c	Call-up voltage relay		→	z30	z30
30a	Pin 2 solenoid A		→	z4	z4
30c	–	Enable external	→	d18	d18
32a	+U <sub>B</sub> operating voltage		→	z30	z30
32c	+U <sub>B</sub> operating voltage	–	→	d18	d18

Table 2: Re-wiring

<sup>1)</sup> If the relevant function has previously been used, please refer to your sales contact partner.

The individual functions that are assigned to the relevant terminals are shown in the block diagrams on the following pages.

Bosch Rexroth AG, RE 30110-Z, edition: 2013-09

## Block diagram/pin assignment VT 3000, VT 3013, VT 3014, VT 3026

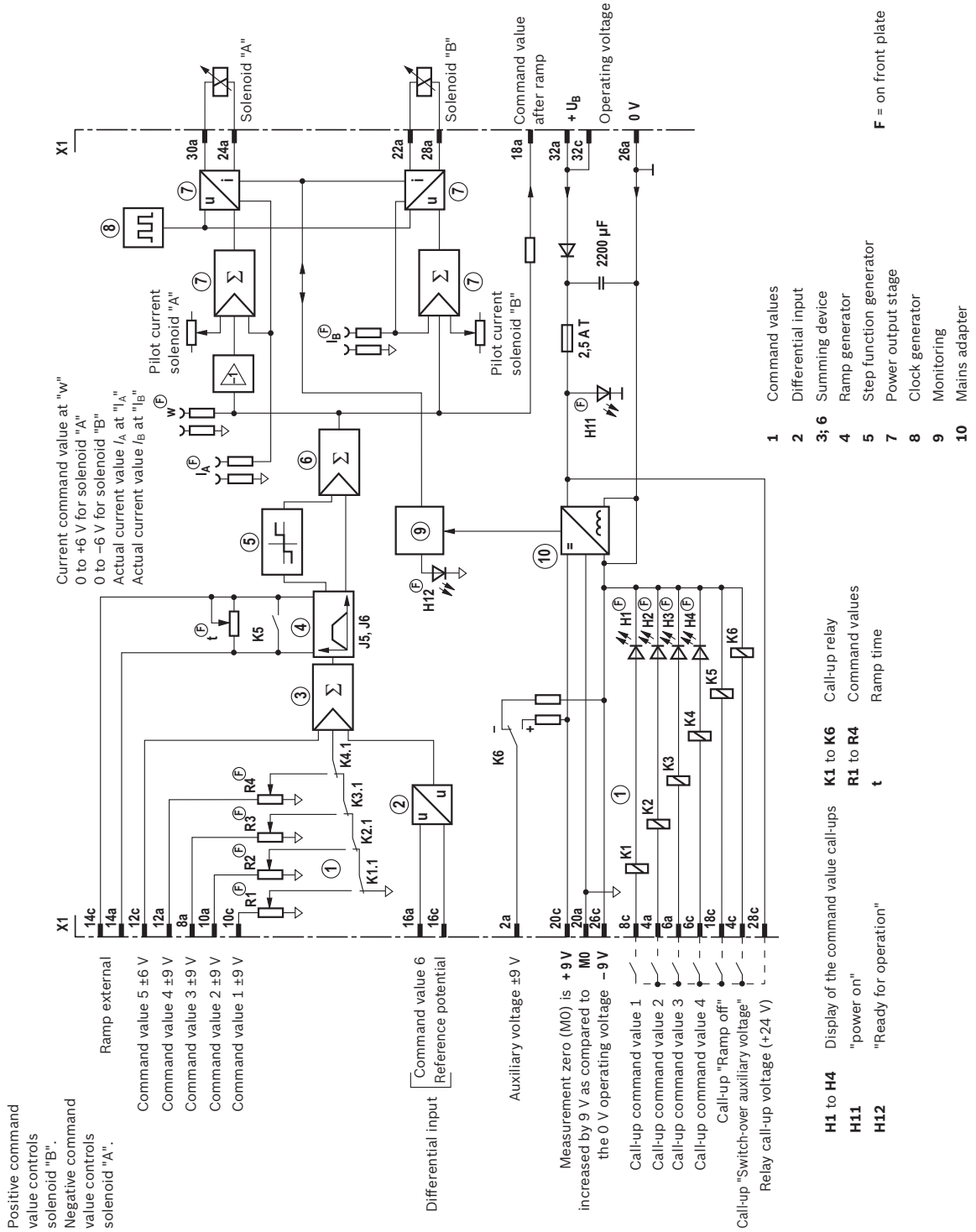

RE 30110-Z, edition: 2013-09, Bosch Rexroth AG

6/12 VT-VSPA2-1-2X/V0/T1, .../T5 | Valve amplifier

## Block diagram/pin assignment VT 3006, VT 3017, VT 3018

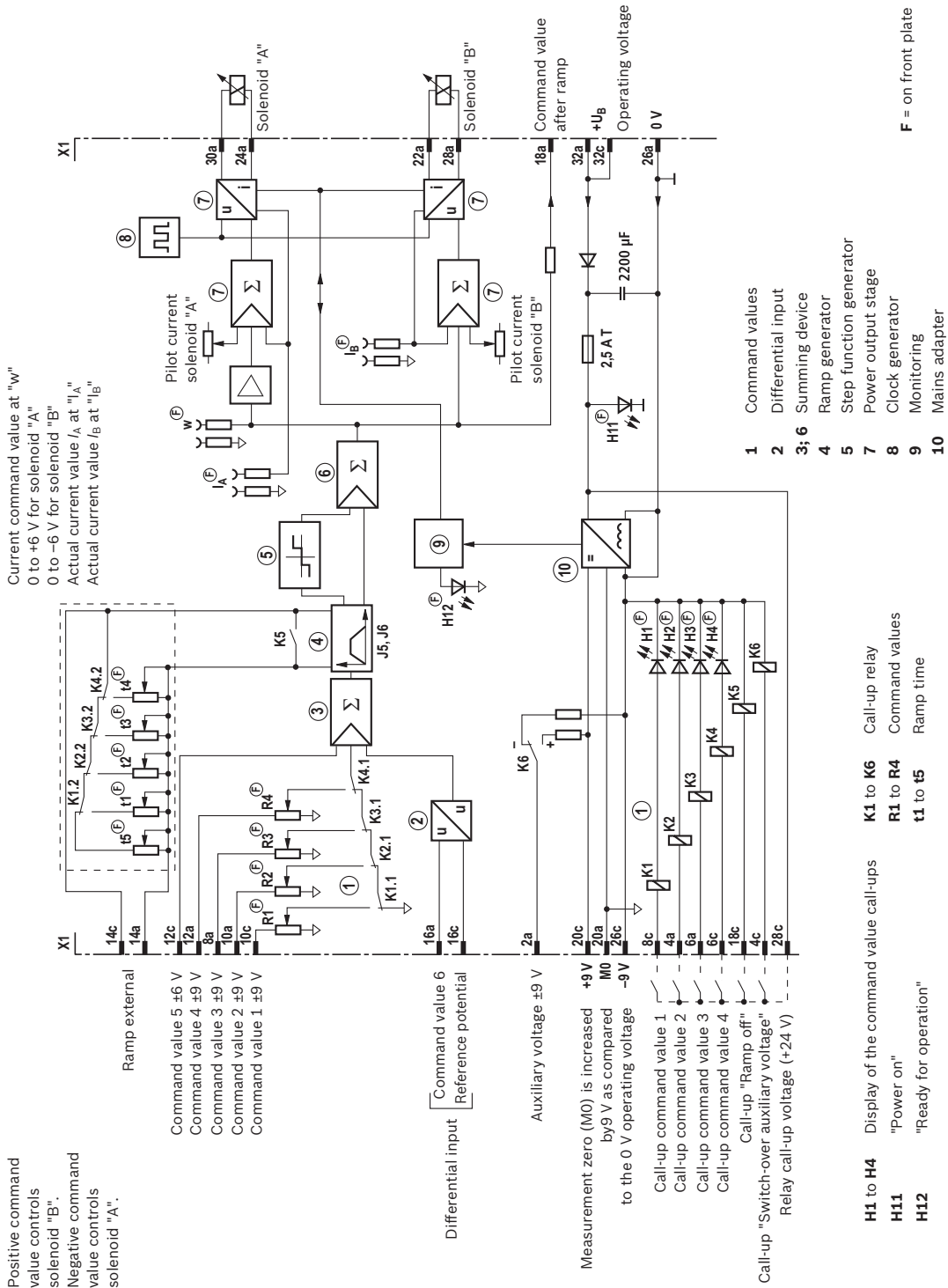

Bosch Rexroth AG, RE 30110-Z, edition: 2013-09

## Block diagram/pin assignment VT-VSPA2-1-1X/T1

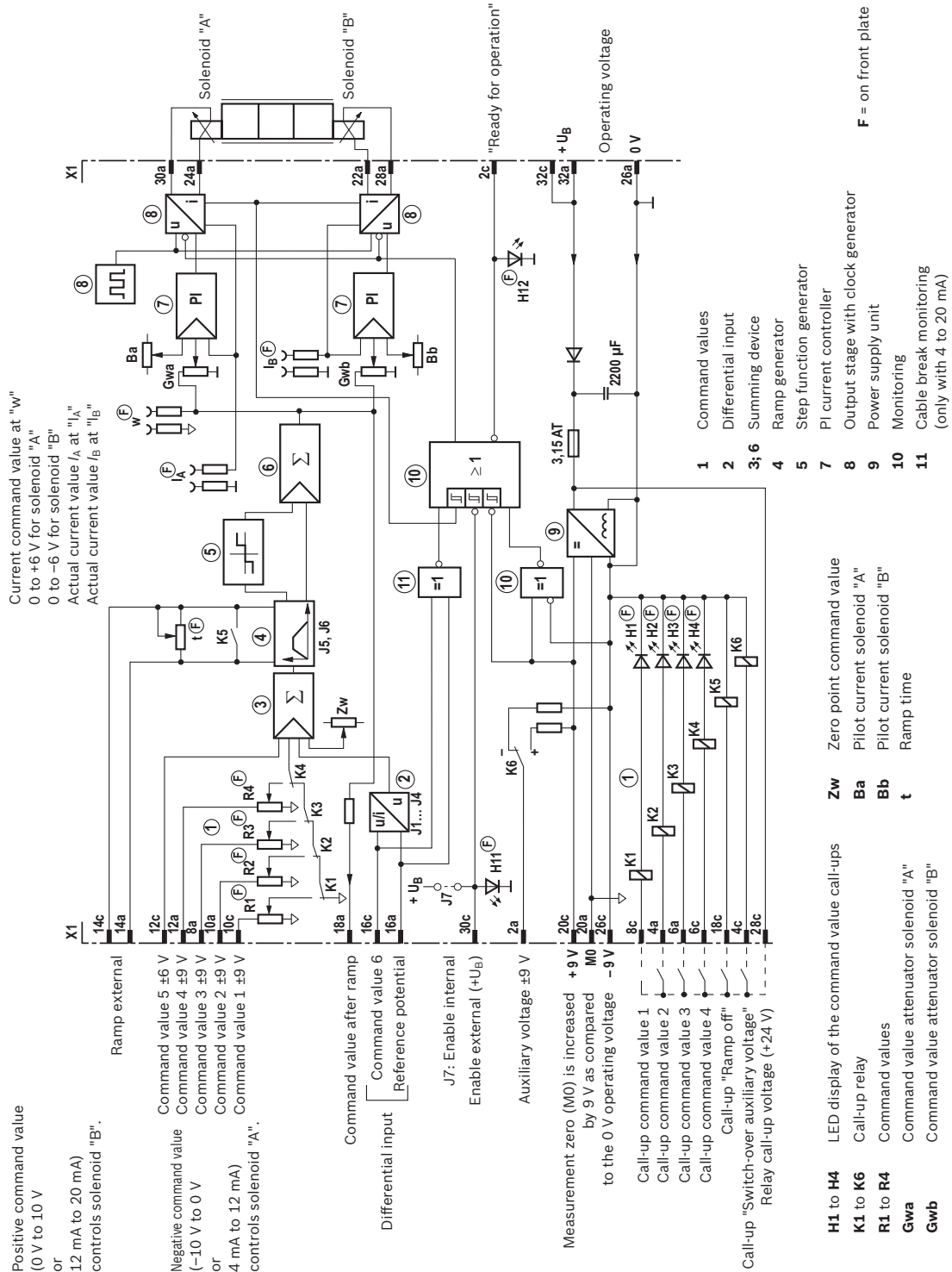

RE 30110-Z, edition: 2013-09, Bosch Rexroth AG

8/12 VT-VSPA2-1-2X/V0/T1, .../T5 | Valve amplifier

## Block diagram/pin assignment VT-VSPA2-1-1X/T5

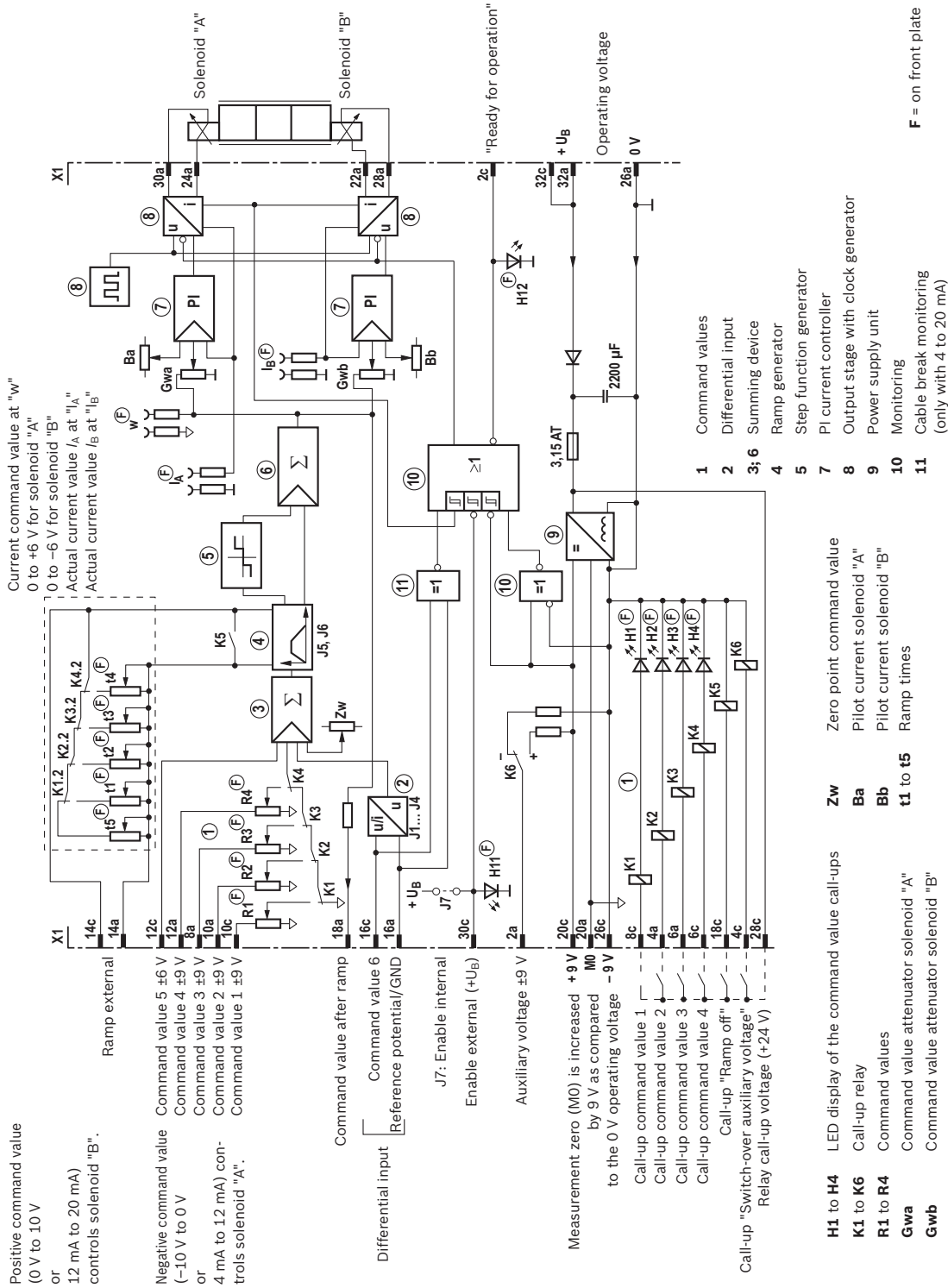

Bosch Rexroth AG, RE 30110-Z, edition: 2013-09

## Block diagram/pin assignment VT-VSPA2-50-1X/T1

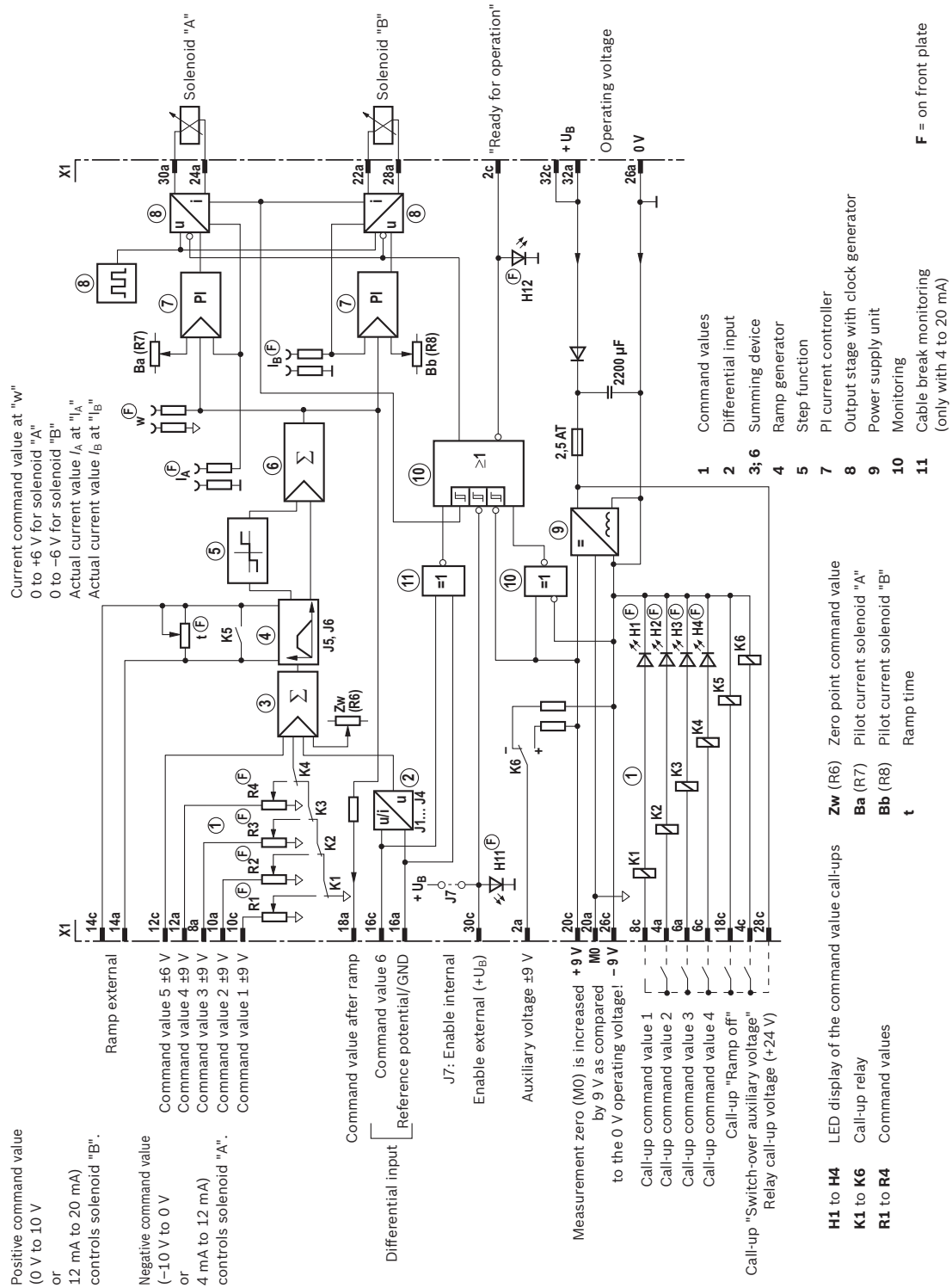

RE 30110-Z, edition: 2013-09, Bosch Rexroth AG

10/12 VT-VSPA2-1-2X/V0/T1, .../T5 | Valve amplifier

## Block diagram/pin assignment VT-VSPA2-50-1X/T5

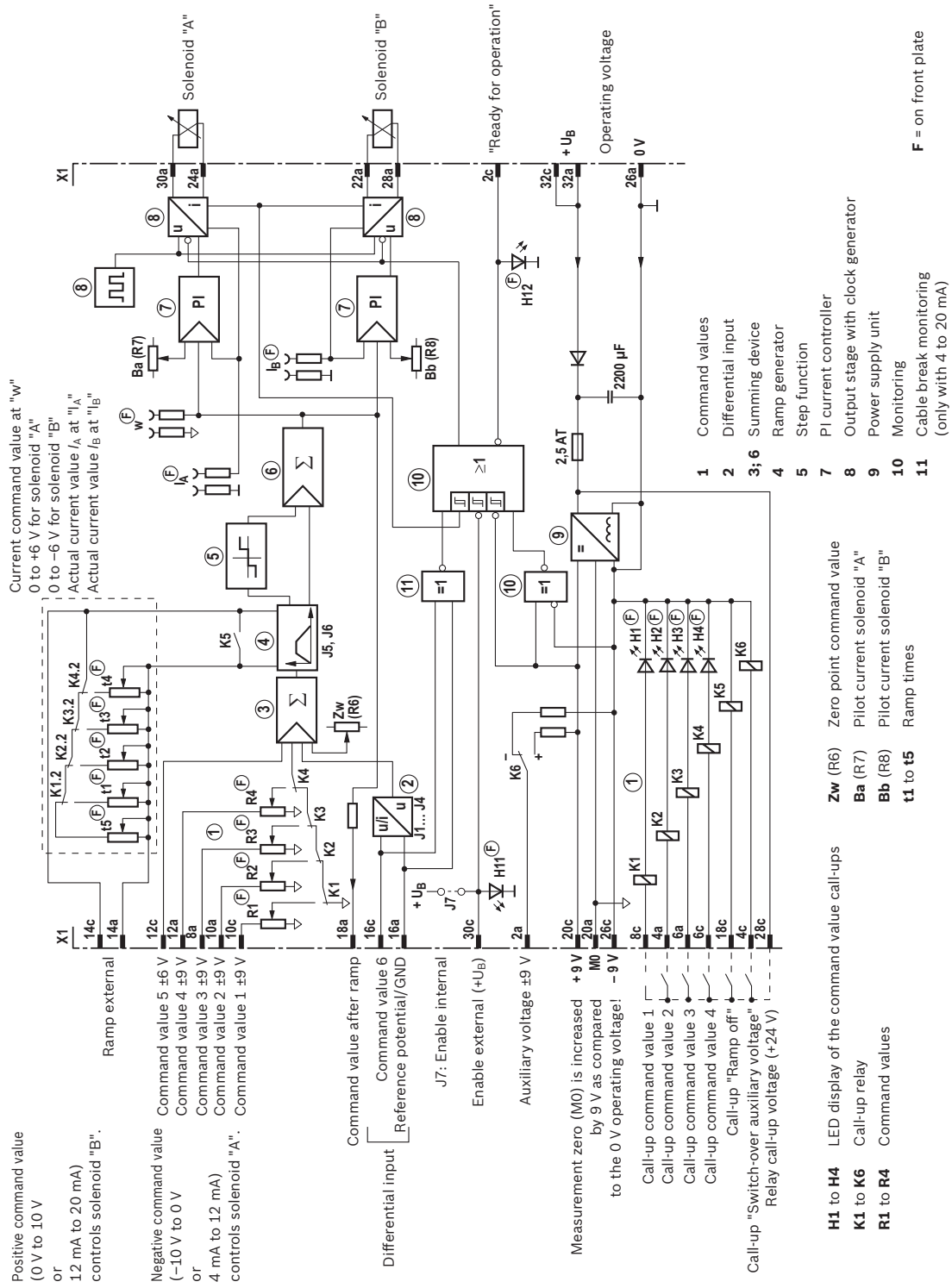

Bosch Rexroth AG, RE 30110-Z, edition: 2013-09

## Commissioning

You must imperatively observe the additional information in the operating instructions RE 30110-B before commissioning the amplifier.

**Step 1** Set the relevant jumper according to table 1.

**Step 2** Set the clock frequency. Use a digital multimeter suitable for frequency measurements in order to do so. Connect the digital multimeter with the measuring sockets "I" and "M0" and using the potentiometer  $f$ , set the frequency according to table 1.

**Step 3:** Set the step level.

**Step 3.1:** Apply +0.1 V at pin b14 at the differential amplifier input and connect pin b16 with 0 V. Using the S+ potentiometer, set the step level according to table 1.

**Step 3.2:** Apply -0.1 V at pin b14 and connect pin b16 with 0 V. Using the S- potentiometer, set the step level according to table 1.

**Step 4:** Set the maximum current.

**Step 4.1:** Apply +10 V at pin b14 and connect pin b16 with 0 V. Using the Gw+ potentiometer, set the maximum current according to table 1.

**Step 4.1:** Apply -10 V at pin b14 and connect pin b16 with 0 V. Using the Gw- potentiometer, set the maximum current according to table 1.

12/12 VT-VSPA2-1-2X/V0/T1, .../T5 | Valve amplifier

## Notes

© This document, as well as the data, specifications and other information set forth in it, are the exclusive property of Bosch Rexroth AG. It may not be reproduced or given to third parties without its consent.  
The data specified above only serve to describe the product. No statements concerning a certain condition or suitability for a certain application can be derived from our information. The information given does not release the user from the obligation of own judgment and verification. It must be remembered that our products are subject to a natural process of wear and aging.

Bosch Rexroth AG, RE 30110-Z, edition: 2013-09