



ROEMHELD
HILMA ■ STARK

Issue 3-15 E

D 8.010

Power Units

energy-saving intermittent cycling

max. flow rate 0.5, (0.8) l/min, max. operating pressure 200 bar

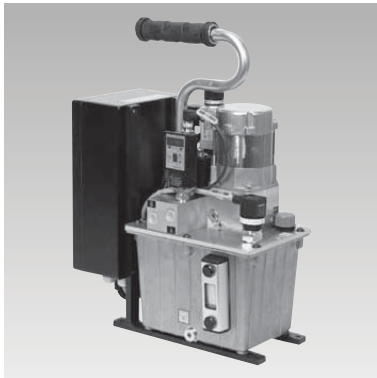

Advantages

- Compact small power unit
- Simple control
- Electronic pressure switch
- Digital pressure display
- Convenient pressure adjustment by teach-in function
- Machine tool interlock as standard
- Electric control ready for connection (optionally also only with terminal box)
- Available for 2 supply voltages
- Oil level and temperature control (option)
- Manual switch or foot switch (alternatively)
- Clutch switch for pressureless coupling and uncoupling of both lines (option)
- Handle for mobile use (option)

Safety features

- Operating pressure infinitely adjustable, therefore precisely defined clamping force
- Electronic pressure switch
- Repeatability ± 1 bar
- Renewed oil supply after a pressure drop of max. 10 %
- Machine tool interlock at a pressure drop of max. 20 %, is automatically updated in case of pressure adjustment
- Oil level and temperature control (option)
- Temperature monitoring of the motor winding
- Screen disks in the ports

Application

These power units are especially suitable for the operation of small and simple hydraulic clamping fixtures. One clamping circuit for single or double acting cylinders is available. The low weight also allows mobile use.

Description

Using this power unit, extension and retraction of the cylinders is effected by the change of the sense of rotation of the electric motor. The pump alternatively supplies to port A or port B. The other port is discharged by opening a pilot-controlled check valve. For coupling and uncoupling of a clamping fixture, both ports can be depressurised by means of the clutch switch.

Important notes

Connect function "Clamping" always at port A. The hydraulic pressure can only be adjusted at port A by means of the electronic pressure switch (digital pressure display). The mechanical pressure switch (without pressure display) at port B is pre-set to 60 bar. If necessary, a pressure change is possible. These power units are exclusively designed for the industrial use of pressure generators for hydraulic fixtures that allow intermittent cycling (see opposite example). All connected hydraulic components must be leakage-free and designed for the maximum operating pressure of the power unit. The power unit generates very high pressures. The connected cylinders generate very high forces so that there is a permanent danger of crushing in the effective area of the piston rod. The manufacturer of the fixture or the machine is obliged to provide effective protection devices. Installation, start up and maintenance have to be made according to the operating instructions by authorised experts. This also applies for mobile use.

Energy-saving intermittent cycling

The electric motor is only running, as long as hydraulic oil is really required, that means to

- extend and retract the clamping cylinders
- build up the operating pressure

Example

Pressure-time diagram for double-acting clamping cylinders

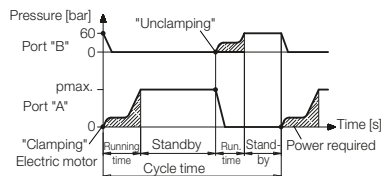

In this example of a hydraulic clamping fixture the running time of the electric motor corresponds to the clamping and unclamping time, which is only a few seconds. In standby mode the power consumption is relatively low. The pressure control is made by a pressure switch, that switches on the electric motor for a short time in case of a pressure drop. The conditions are leakage-free clamping elements and accessories.

Available supply voltages

3-phase motor 400 V

For stationary and mobile applications. With terminal box or with complete electric control. On request also with connecting cable and CEE plug.

Direct current 24 V

For the low voltage range. Only available with terminal box.

Hydraulic circuit diagram

Single-acting and/or double-acting hydraulic cylinders can be connected.

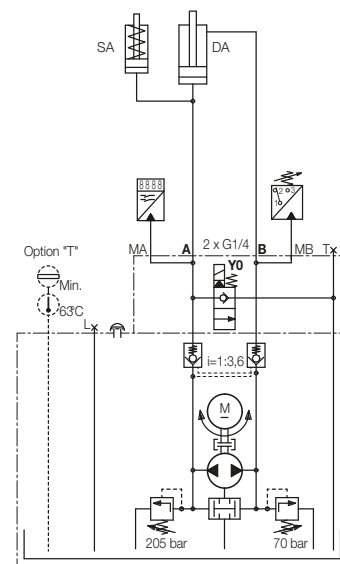

Port A

Clamping adjustable 30...200 bar
Control Electronic pressure switch
Integrated machine tool interlock

Port B

Clamping permanently set approx. 60 bar
Control Mechanical pressure switch

Solenoid valve Y0

With the valve Y0 port A will be depressurised in order to allow

- quick return of single-acting cylinders when unclamping;
- with the optional clutch switch both ports can be depressurised during coupling and uncoupling.

The solenoid valve Y0 is electrically operated in switch position "Unclamping" or "Clamping".

Mains voltage 400 V Y 50 Hz
Flow rate max. 8.75 cm³/s (0.52 l/min)

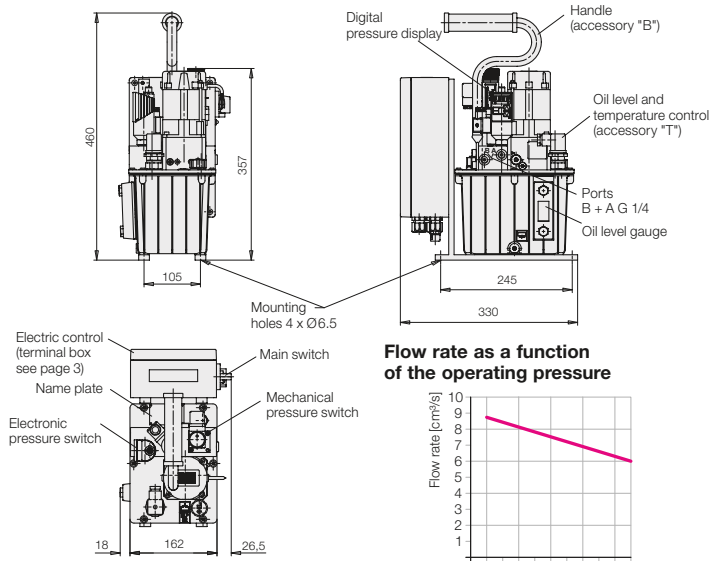

Flow rate as a function of the operating pressure

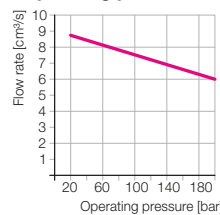

Hydraulic circuit diagram

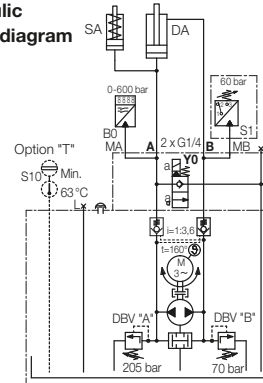

Terminal box

Electric motor, solenoid valve Y0 and the two pressure switches are connected to a terminal strip.

The motor control and the direct current voltage supply 24V DC are to be realised by the customer (see electric circuit diagram page 4).

Electric control

After filling of hydraulic oil and connection of the electric lines, the power units are ready for operation.

External release

In the electric control, the terminals 1 and 21 are provided for an external release of the circuit breaker of the pump motor (24 VDC).

Clutch switch

Besides "clamping" and "unclamping", the two ports A and B will be depressed in the third switching position.

When using a coupling unit as per data sheet F 9.425, mounted on a clamping pallet, coupling and uncoupling is easily possible, despite of the fact that the workpiece is still clamped.

Machine tool interlock MI

The lower switching point (80 % of the clamping pressure) of the electronic pressure switch is firmly programmed and is automatically stored in teach mode for the desired clamping pressure by pressing a button.

Two potential-free terminals are available, that can be connected with the control of the machine tool.

Messages:

- (1) Clamping pressure available
→ workpiece can be machined
- (0) Clamping pressure dropped below 80 %
→ Stop machining immediately

Power units with accessories

CEE connecting line "A"

Length approx. 3.5 m with CEE plug

Part no.	8403-211A
	8403-212A
	8403-213A
	8403-214A

Handle "B"

Part no.	8403-211B
	8403-212B
	8403-213B
	8403-214B

Oil level and temperature control "T"

Switches off the electric motor, if the oil level is too low and/or the oil temperature rises above 63 °C.

Part no. **8403-2XXT**

Different combinations

The options described above can also be combined, e.g.

Part no. **8403-213ABT**

General characteristics

Design	Radial piston pump
Direction of rotation	Clockwise / counterclockwise rotation
Connection	Fittings G1/4 with screwed plug type B or E as per DIN 3852
Fixation	4 screws M 6
Mounting position	upright
Environmental temperature	-10...+40 °C
Max. oil temperature	+ 60 °C
Weight	approx. 16 kg

Hydraulic parameters

Max. flow rate	8.75 cm ³ /s (0.52 l/min) (see diagram)
Operating pressure range "A" and "B"	30...200 bar
Port "B" preset	60 bar
Viscosity range	10...100 mm ² /s
Recommended viscosity class	ISO VG 32 as per DIN 51524
Recommended hydraulic oil	HLP 32 as per DIN 51524-2 (other media on request)
Filling quantity	3.5 l usable 1.5 l

Electric motor

Type	Three-phase motor, 2-pole
Rating	0.15 kW
Speed	3000 min ⁻¹
Nominal voltage / supply voltage	400 V Y 50 Hz
Nominal current at 400 V	0.55 A
Operating mode	Intermittent cycling S3 as per VDE 0530
Max. relative cycle time	10 % ED (running time 60 s)
Motor overload protection	Temperature switch

Electric control

Main switch	With overcurrent and undervoltage releases, lockable
Control electric motor	Reversing contactor control by pressure switch
Control voltage	24 V DC
Fuses external	required 3 x 6 A slow
Code class	IP 54
Supply line required	4 x 1.5 mm ²
Manual switch	8 x 1 mm ² approx. 3 m long
Foot switch	9 x 1 mm ² approx. 3 m long
Clutch switch	9 x 1 mm ² approx. 3 m long

Terminal Box	Electric control	Pressure switch		MI	External release	Switch			Clutch switch	Part no.
		electrical	mechanical			without	hand	foot		
•	•	1	1	•	•	•				8403-202
	•	1	1	•	•	•				8403-211
	•	1	1	•	•		•			8403-213
	•	1	1	•	•			•		8403-214
	•	1	1	•	•				•	8403-212

Supply voltage 24 V DC
Flow rate max. 13.3 cm³/s (0.8 l/min)

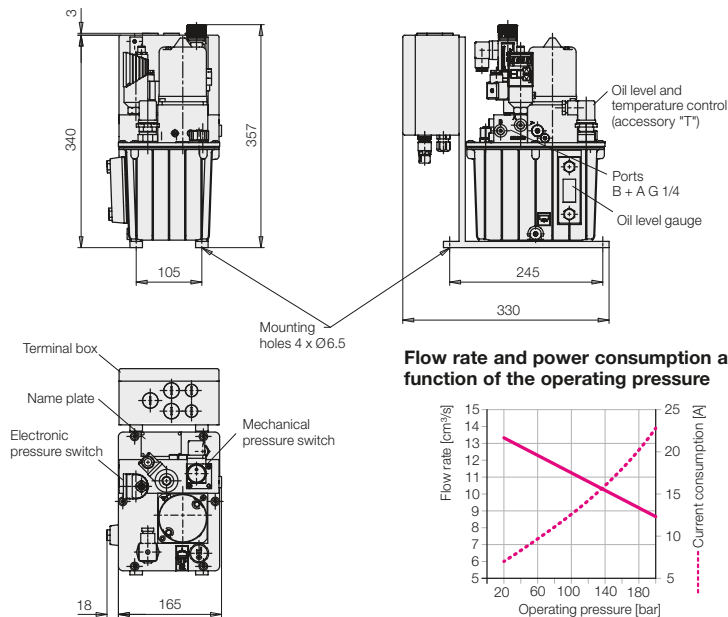

Hydraulic circuit diagram

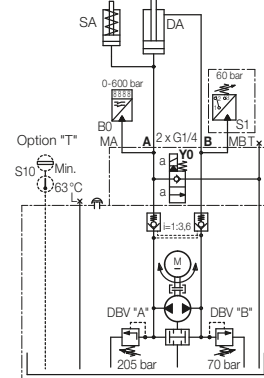

Flow rate and power consumption as a function of the operating pressure

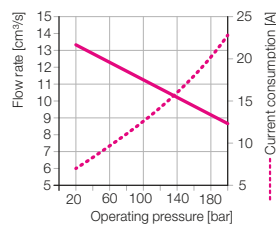

General characteristics

Design	Radial piston pump
Direction of rotation	Clockwise / counterclockwise rotation
Connection	Fittings G1/4 with screwed plug type B or E as per DIN 3852
Fixation	4 screws M 6
Mounting position	upright
Environmental temperature	-10... +40 °C
Max. oil temperature	+ 60 °C
Weight	approx. 15 kg

Hydraulic parameters

Max. flow rate	13.3 cm ³ /s (0.8 l/min) (see diagram)
Operating pressure range "A" and "B"	30... 200 bar
Port "B" preset	60 bar
Viscosity range	10... 100 mm ² /s
Recommended viscosity class	ISO VG 32 as per DIN 51524
Recommended hydraulic oil	HLP 32 as per DIN 51524-2 (other media on request)
Filling quantity	3.5 l usable 1.5 l

Electric motor

Type	Direct current brush motor
Rating	0.19 kW
Nominal voltage	24 V DC
Nominal current	max. 22 A
Operating mode	Intermittent cycling S3 as per VDE 0530
Max. relative cycle time	10 % ED (running time 60 s)
Code class	IP 40

Solenoid valve Y0

Rating	21 W
Nominal voltage	24 V DC
Nominal current	0.89 A
Duty cycle	100 % ED

Electric control

Control electric motor	Pole changing (by the customer) switching by pressure switch
Control voltage	24 V DC

Terminal box

Electric motor, solenoid valve Y0 and the two pressure switches are connected to a terminal strip.

The motor control and the direct current voltage supply 24V DC are to be realised by the customer (see electric circuit diagram page 4).

Machine tool interlock

The lower switching point (80 % of the clamping pressure) of the electronic pressure switch is firmly programmed and is automatically stored in teach mode for the desired clamping pressure by pressing a button.

A connecting terminal of the switching output of the electronic pressure switch is available (24 VDC; 1 A; pnp switching).

That can be used to control a switch relay (on the customer side). The control of the machine tool will be switched to a contact free of potential.

Messages:

- (1) Clamping pressure available
→ workpiece can be machined
- (0) Clamping pressure dropped below 80 %
→ Stop machining immediately

Power units with accessories

Oil level and temperature control "T"

Switches off the electric motor, if the oil level is too low and/or the oil temperature rises above 63 °C.

Part no.

8403-302T

Terminal Box	Pressure switch		MI	without switch	Part no.
	electronic	mechanical			
•	1	1	•	•	8403-302

Electric circuit diagrams

Electric control for 8403-211/212/213/214

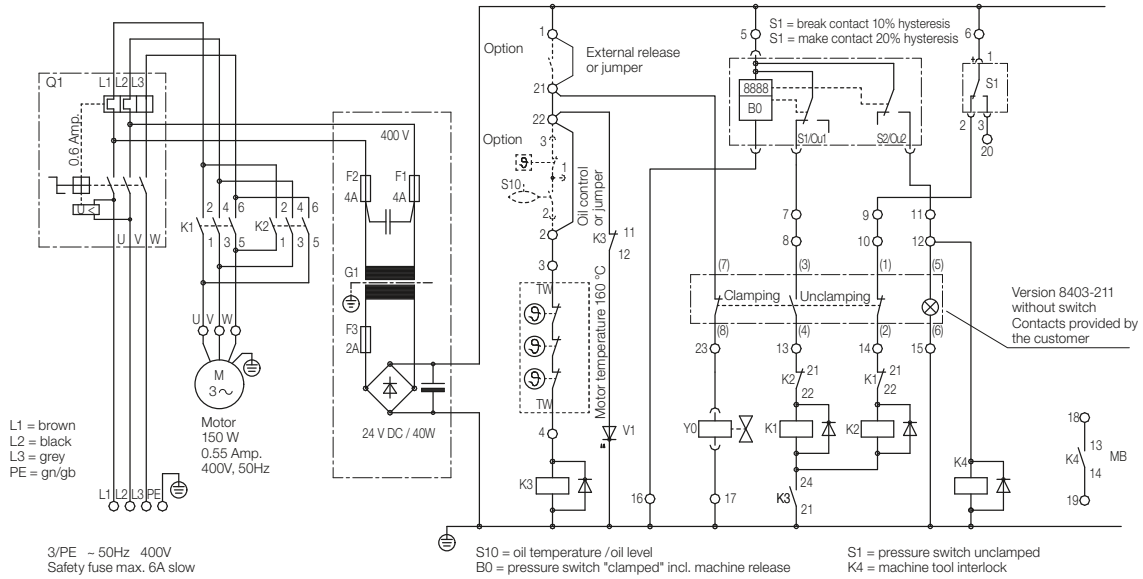

Terminal box for 8403-202

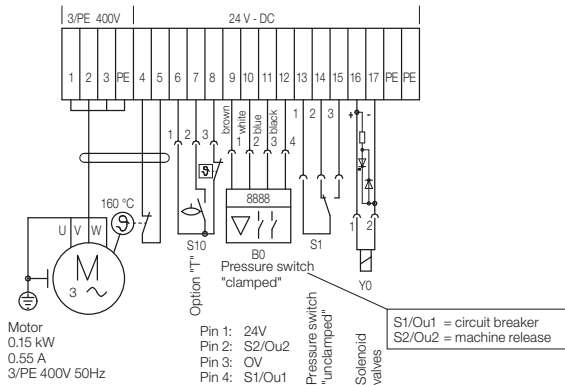

Terminal box for 8403-302

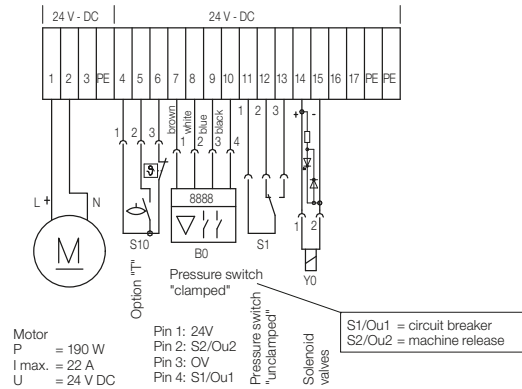

Switching logic for clockwise/counterclockwise rotation and solenoid valve Y0

	Unclamping Pressure "B"	Clamping Pressure "A"	Coupling
Motor running clockwise	0	1	0
Motor running counterclockwise	1	0	0
Actuation of valve Y0	1	0	1

Example for motor pole changing 24VDC

