



**ROEMHELD**  
HILMA ■ STARK

Issue 6-00 E

# B 1.560

## Block Cylinder, with Anti-Rotation Piston aluminium housing for adjustable magnetic sensors, double acting, max. operating pressure 350 bar

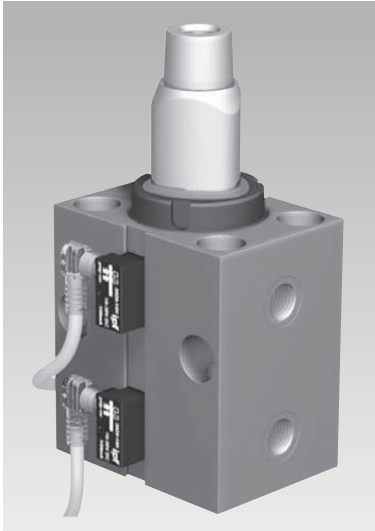

The polygonally-shaped piston rod of this block cylinder is located in a long guide bushing which compensates also larger torques and radial forces.

The 1:10 cone is used for backlash-free transmission of the forces between tool and piston rod.

The cylinder housing has the same dimensions and fixing possibilities as the block cylinders as per data sheet B 1.554.

Easily monitorable control of the piston position with magnetic sensors which are available as accessories is the same as per data sheet B 1.554.

### Important notes

Tools, which are fixed at the piston of the block cylinder, are also guided. An external guide has to be avoided, since this overdetermination would lead to over-stressed conditions and thereby to increased friction and wear.

Operating conditions, tolerances and other data see data sheet A 0.100.

### Please use only fittings with soft seals,

see data sheet B 1.554

Block cylinders with aluminium housing are **not suitable for operation of blanking and punching dies**. Uncontrollable spikes and vibrations can appear which especially in the case of aluminium could cause a decrease in tool life.

Steel can influence the magnetic field of the magnetic piston and thereby the position of the switching points. If there is the same influence for each stroke (e.g. because of adjoining steel components) it can be compensated by displacing the magnetic sensors. But if the influence differs from stroke to stroke, as e.g. in the case of swarf, a cover has to be provided 30 mm over the magnetic sensors.

Covers have to be provided to protect the cylinders against ferritic swarf.

Piston material: case hardening steel, hardened  
Cylinder body material: anodized aluminium alloy

### Throttling of the flow rate

Throttling has to be made in the oil supply line to the block cylinder to rule out a possible pressure intensification and thereby pressures over 350 bar. The hydraulic circuit diagram shows flow control valves which allow oil return from the block cylinder without any impediments.

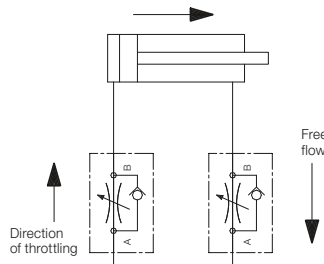

### Advantages

- Anti-rotation piston
- No additional guides required
- No squeezing points
- Space-saving design
- Low weight due to alu-housing
- Compensation of radial torque, independent of the piston position
- Radial play max.  $\pm 0.3$  degrees
- Compensation of cross forces, also eccentric load possible
- Robust fixing of tools due to proven 1:10 cone
- Increased rigidity due to big piston rod diameter
- Integrated magnetic piston for continuous control of the piston position by means of standard magnetic sensors.
- Universal fixing possibilities
- Simple adaptation to different strokes

### Application

The special feature of this block cylinder is the piston rod with polygonal profile to prevent rotation. The installed guide is in the position to compensate torque and radial forces, thereby the block cylinder with guide is suited for the following applications:

- Direct operation of tools for joining, punching, pressing, and stamping.
- Guided operation of tool sets (cutters, stamps, etc.) e.g. for finishing of pressed plastic mould parts.
- Guided displacement and pressing-in of assembly tools.
- Guided pressing-out of disassembly tools.

### Description

The successful block cylinder series with aluminium housing for adjustable magnetic sensors has been expanded by a variant with piston to prevent rotation.

Normally a hydraulic cylinder cannot be used as guiding element. External guides require space and are expensive.

### Fixing possibilities

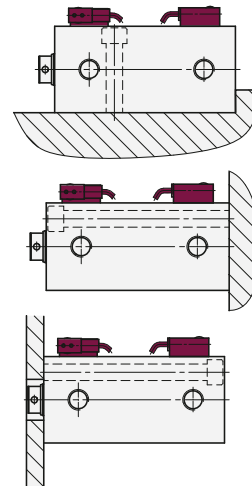

### Application example

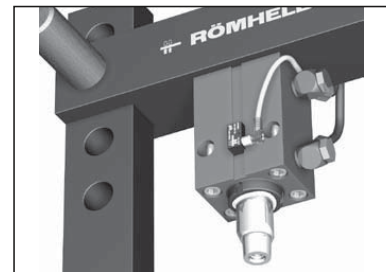

Guided pressing in with a variable press-in device

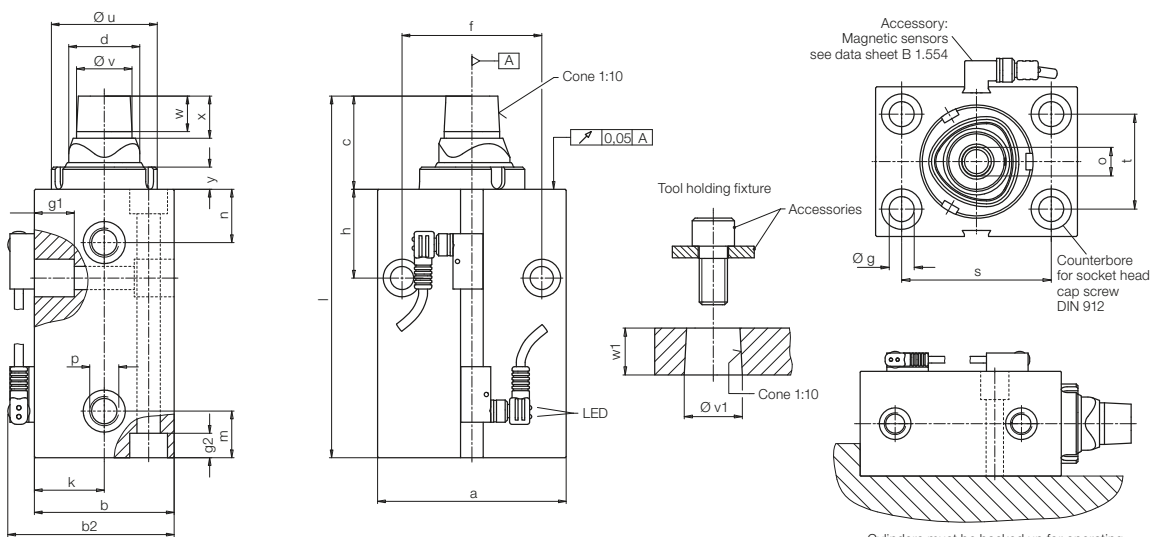

Cylinders must be backed up for operating pressures exceeding 160 bar

Piston Ø D	[mm]	32	40	50
Profile of the rod P3G d	[mm]	22	32	40
Force to push at				
100 bar	[kN]	8.0	12.5	19.6
350 bar	[kN]	28.1	44	68.7
Force to pull at				
100 bar	[kN]	4.2	4.5	7.1
350 bar	[kN]	14.8	15.8	24.7
Adm. torque	[Nm]	20	40	60
Adm. lateral force against the piston rod	[kN]	2.8	4.4	6.9
Oil volume per 10 mm stroke				
Stroke to extend	[cm <sup>3</sup> ]	8.04	12.56	19.63
Stroke to retract	[cm <sup>3</sup> ]	4.2	4.5	7.1
a	[mm]	75	85	100
b	[mm]	55	63	75
b2	[mm]	67	75	87
c	[mm]	33	42	50
f	[mm]	55	63	76
Ø g	[mm]	10.5	10.5	13
g1 both sides	[mm]	16	17	22
g2 both sides	[mm]	11	11	13
h	[mm]	38	40	44
k	[mm]	27.5	31.5	37.5
m	[mm]	20	21	21
n	[mm]	22	24	27
o x thread depth	[mm]	M10x21	M12x20	M16x25
p		G1/4	G1/4	G1/4
s	[mm]	55	63	76
t	[mm]	35	40	45
Ø u	[mm]	38	48	58
Ø v	[mm]	20	25	32
Ø V1 +0.10/+0.05	[mm]	19.8	24.8	31.8
w	[mm]	13	16	20
w1	[mm]	16	20	23
x	[mm]	16	19	23
y	[mm]	8	10	11
<b>Stroke +/-1</b>	[mm]	<b>25</b>	<b>25</b>	<b>25</b>
Total length +/-1	[mm]	123	138	157
<b>Part no. (without magnetic sensors)</b>		<b>1564-105</b>	<b>1565-105</b>	<b>1566-105</b>
<b>Stroke +/-1</b>	[mm]	<b>50</b>	<b>50</b>	<b>50</b>
Total length +/-1	[mm]	148	163	182
<b>Part no. (without magnetic sensors)</b>		<b>1564-165</b>	<b>1565-165</b>	<b>1566-165</b>
<b>Stroke +/-1</b>	[mm]	<b>100</b>	<b>100</b>	<b>100</b>
Total length +/-1	[mm]	198	213	232
<b>Part no. (without magnetic sensors)</b>		<b>1564-195</b>	<b>1565-195</b>	<b>1566-195</b>
<b>Accessories</b>				
Socket head cap screw DIN 912		M10x25	M12x25	M16x30
<b>Part no.</b>		<b>3300-277</b>	<b>3300-054</b>	<b>3301-327</b>
Disk DIN 6340		10.5x28x4	13x35x5	17x45x6
<b>Part no.</b>		<b>3511-320</b>	<b>3511-330</b>	<b>3511-350</b>