



ROEMHELD
HILMA ■ STARK

Issue 9-11 E

B 1.462

Built-in Piston

single acting with spring return
max. operating pressure 250 bar

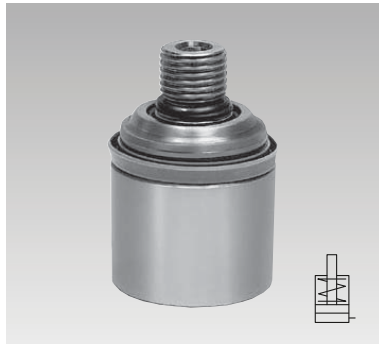

Element

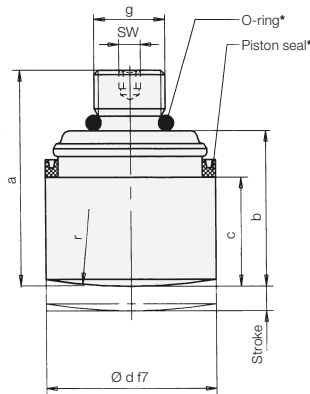

Location hole

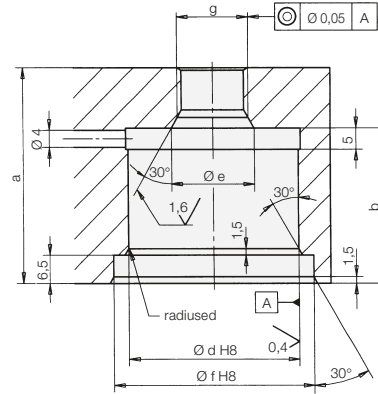

Wiper

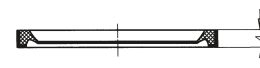

Application

Easy installation in bars and blocks. Suitable for workpiece clamping and locking as well as for perforating, punching and stamping of sheet steel.

Very suitable for narrow and flat installation spaces. Compact multiple arrangement is possible. Mounting position: any. Hydraulic oil supply through drilled holes in the base. Only one oil port required.

Description

Plunger piston with integrated pull-back spring, stroke limitation and fastening screw form a unit that cannot be disassembled. With PTFE-type piston seal. O-ring as static seal. Piston hardened and ground.

Wiper for case mounting supplied upon request.

Special seals on request.

Advantages

- low built-in height
- very compact design
- extremely low overall height despite of return spring and fully utilisable stroke limitation
- easily exchangeable
- high force density

Note:

Lateral forces less than 5% of clamping forces. To ensure perfect function, built-in dimensions and surface qualities are to be strictly observed. Use Allen key for assembly and disassembly. Replace O-ring after disassembly. Max. service temperature 80°C. Use Loctite no. 242 to secure thread.

Important notes

Operating conditions, tolerances and other data see data sheet A 0.100

Power units see catalogue section "D".

Clamping force at 250 bar	[kN]	12.25	20	31.25	48.75
100 bar	[kN]	4.9	8	12.5	19.5
Spring return force. min.	[N]	130	200	230	400
Piston Ø d	[mm]	25	32	40	50
Stroke	[mm]	8	8	8	12
Total oil volume	[cm ³]	4	7	10	24
a ±0.3	[mm]	40.3	47.3	50.3	75.3
b +0.4	[mm]	32.5	34.5	36	56
c	[mm]	23.5	25	26	43
e	[mm]	11.5	14	19.5	24
f	[mm]	32	42	47	58
g		G 1/8	G 1/4	G 3/8	G 1/2
r	[mm]	50	100	150	200
SW	[mm]	4	6	6	8
Seating torque	[Nm]	10	20	25	30
Weight	[kg]	0.10	0.17	0.28	0.59
Part no.		1072-010	1073-010	1074-010	1075-020
Wiper	Part no.	3000-838	3000-710	3000-649	3000-484
Seal kit	Part no.	5700-005	5700-006	5700-007	5700-008
Mounting sleeve	Part no.	5700-009	5700-010	5700-011	5700-012

* O-Ring and piston seal are delivered with built-in piston

Mounting sleeve and wiper

Use absolutely necessary!

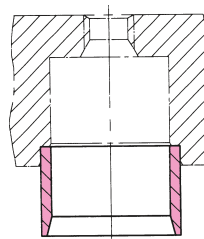

Application example

