

HYDAC INTERNATIONAL

Return Line Suction Boost Filter RKM. The New Generation.

Optimized for service. Optimized for efficiency. Quality protected.

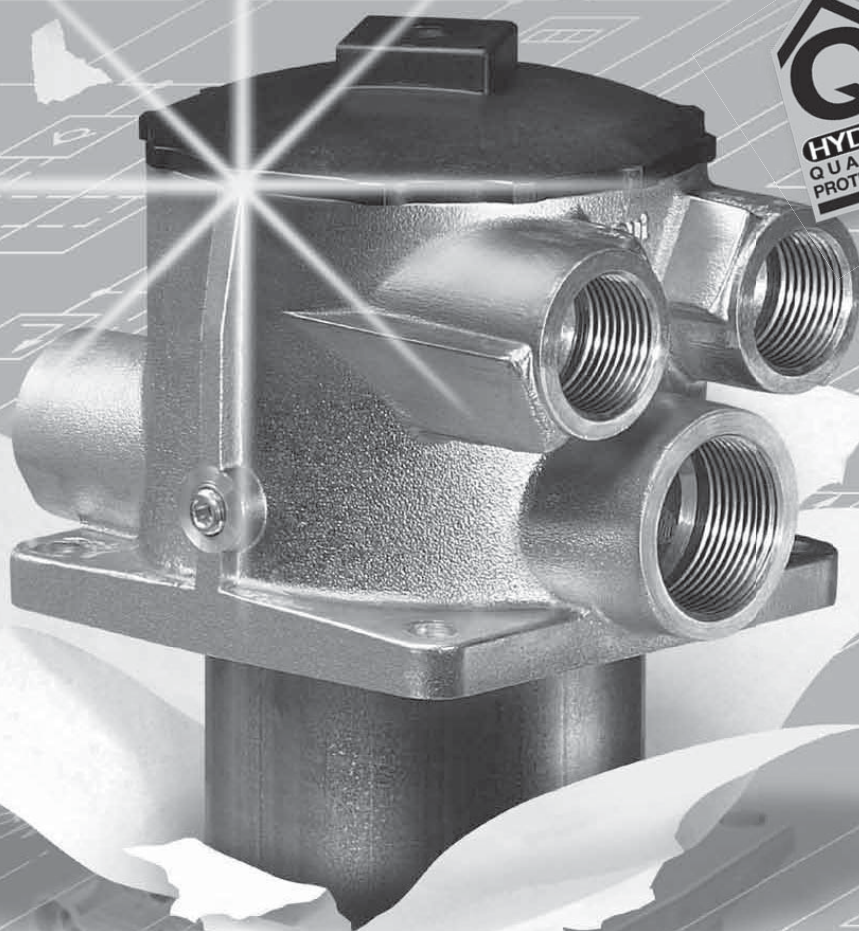

E 7.124.0/03.12

HYDAC 189

HYDAC RKM - New for Mobile:

Space saving

the need for at least one filter is eliminated

Reduced maintenance costs

reduces maintenance by at least half

First class component protection

excellent filtration efficiency of the filter element which is optimized for cold starts

Increased operating reliability

new High Efficiency filter element technology

Warranty security

individual branding

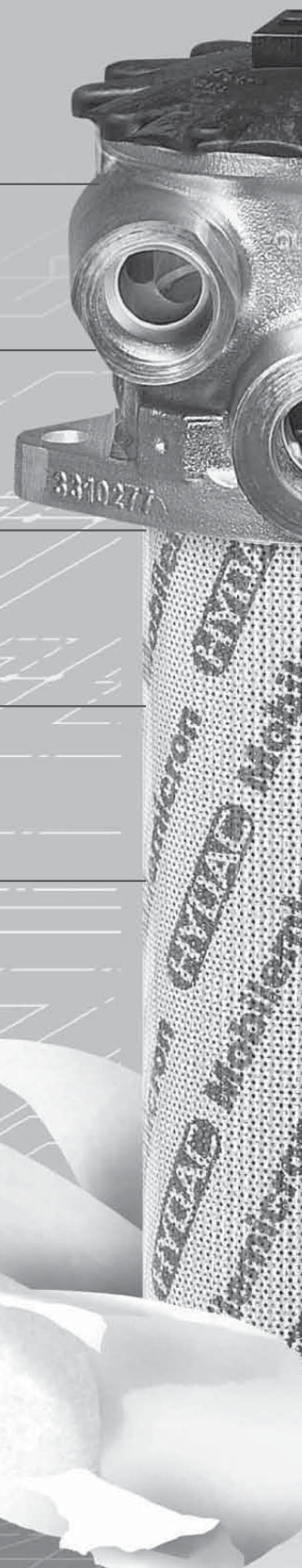

E 7-124.0/03.12

190 | HYDAC

The New Generation: The New Optimum.

First class pump protection

cavitation is reliably prevented

Flexible use

numerous connection options

Improved ease of maintenance

new design optimized for service

Long service life

high contamination retention

Guaranteed HYDAC quality

thanks to HYDAC Quality Protection



Your Professional Partner for Mobile Applications

With over 5,500 employees worldwide, HYDAC is one of the leading suppliers for fluid technology, hydraulic and electronic equipment.

With 40 overseas companies and over 500 sales and service partners we are a global player.

Our wide range of products, combined with our well-grounded expertise in all aspects of mobile machines, ensures HYDAC is qualified to be your professional partner for the mobile sector. Especially in the area of hydraulic filtration, you will benefit from decades of HYDAC experience and development successes.

Our quality and environment certification to ISO 9001/2000 and ISO 18001 denote first class quality and responsible management of our resources.

All from one supplier.

HYDAC will help find the solution for you!

From first class components right up to turnkey system solutions, from support during commissioning to maintenance and optimization, from professional filtration, to oil condition monitoring and expert cooling.



First class laboratory and testing expertise in the HYDAC Technical Centre

The new Technical Centre, specifically designed for filters and filter monitoring, is equipped with the most up-to-date instruments and test rigs. It offers a huge range of options for fluid analysis and filtration efficiency tests.

In our new laboratories, highly qualified staff are dedicated to continuously improving products and developing applications as well as carrying out analyses to customer specification – always tailored to the particular operating conditions.

In addition to the central facility at our headquarters there are further laboratories and mobile fluid laboratories in several HYDAC centres in Germany and overseas.



Just one example of the numerous filter testing procedures: **Multipass test rig.**

Oil analysis in the HYDAC laboratory at company headquarters.

With Us, You and Your Fluids are in the Safest Hands.

The specialists at HYDAC have a good knowledge of your fluid and welcome the opportunity to help you reduce the burden of fluid service. You will see for yourself the clear benefit of having a hydraulic or lubrication system that works perfectly, leaving you to concentrate fully on your area of expertise.

When you have decided on a HYDAC filter concept for your mobile machine, you are not "just" buying a filter, but you are also benefitting at the same time from the HYDAC network of expertise and service available worldwide:

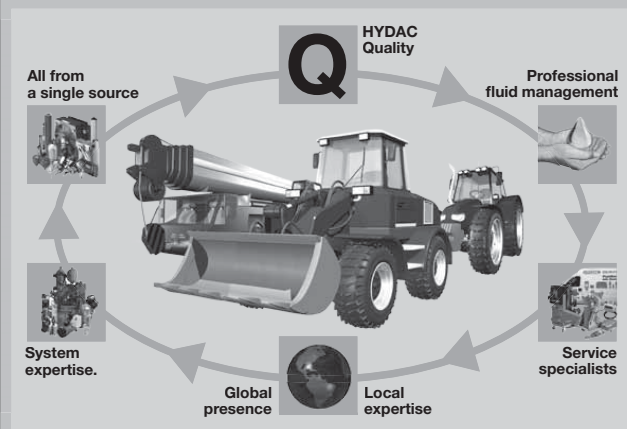

Highest level of operating reliability for mobile applications.

In HYDAC you have a professional partner for all aspects of fluid cleanliness

This product overview shows just a single filter type. The whole filter range from HYDAC covers approximately fifty other types – the majority of which have been developed for mobile applications.

In addition, new individual solutions are constantly being developed, partly in active development partnership with the manufacturers.

HYDAC filters offer you the following advantages.

Low costs

the filter elements and housings are optimized for the mobile sector

Easy maintenance

simple element change and easy-to-install filter housing

High level of operating reliability

filter media have high filtration efficiency for exceptional cleanliness classes and benefit from a high level of production quality

Low operating costs

particularly low pressure drops across filter and filter element for low energy consumption

All components and systems from one company

providing comprehensive system know-how and integrated system approach

Worldwide availability and advice

provided by our worldwide network of regional offices, agents and service partners

Protection of the spare part business

thanks to special features such as "Brand Labelling" and "Quality Protection"

E 7.124.0/03.12

HYDAC

Return Line Suction Boost Filter RKM.

Filter housing optimized for service.

Never before has the RKM been so easy to service:

The element is, as previously, lifted with the the filter bowl out of the tank-mounted head of the filter.

What's new is that the element is now firmly screwed to the bowl.

It will not become loose and can be lifted out smoothly. In addition, the convenient removal handle makes for a clean and easy element change.

Special advantage: the optional patented oil drain valve opens automatically to the tank when the filter cover plate is opened.

Customer benefits of the new generation:

Improved ease of maintenance no risk of injury

since the element is securely attached to bowl and a convenient removal handle is provided

Cleaner element change

element firmly attached to bowl and automatic oil drain valve available (as an option)

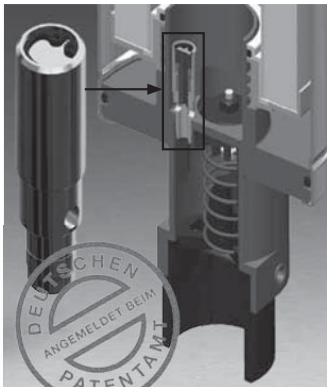

Patented oil drain valve.

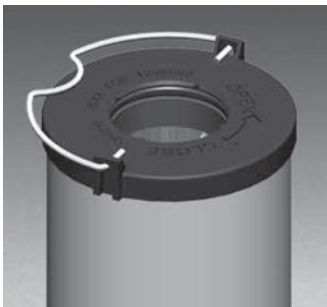

Element with removal handle.

Filter elements optimized for efficiency.

In the Return Line & Suction Boost Filter RKM

special "Mobilemicron" filter elements have always been used which have an exceptionally good pressure drop characteristic.

In other words, for the same ambient conditions and flow rate,

Mobilemicron elements produce significantly lower Δp than comparable hydraulic elements.

For the new generation we have gone one better: **Mobilemicron elements in a High-Efficiency version** achieve particularly high separation rates. That means **still greater efficiency** for these already highly efficient Mobilemicron filter elements.

Customer benefits of the new generation:

Excellent component protection and increased machine availability due to the outstanding filtration efficiency of the new High Efficiency elements

Protection of the shaft seals of the hydrostatic drive

particularly low pressure drop across the element (especially during cold start)



Mobilemicron filter elements.

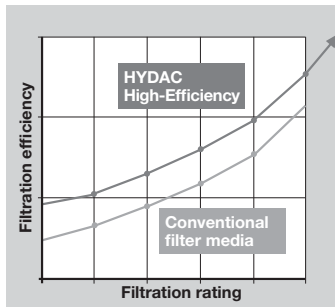

High-Efficiency graph.

Quality Protection

The new RKM is equipped with a "Quality Protection solution". The anti-copying measures built into the top quality original elements prevent counterfeit elements being fitted.

In addition, the RKM elements can of course be overprinted as usual with your company logo (Brand Labelling).

Overprinting also supports the exclusive use of original elements.

Customer benefits of the new generation:

Outstanding quality of the replacement element and with that, long service life of element and components, guaranteed cleanliness and high level of operating reliability

Safeguarding of the spare parts business particularly for OEMs

Guaranteed spare part quality and therefore oil cleanliness in respect of warranty claims

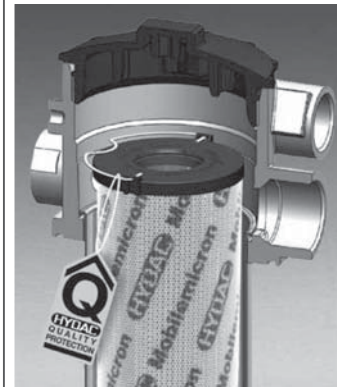

Quality Protection. (Integrated anti-copying design)



Brand Labelling. (Element with customer logo)

E 7.124.0003.12

The New Generation: Optimized for Service.

A filter crammed with cutting-edge technology.

The new RKM has not only been optimized in terms of service, efficiency and quality, but it also triumphs in terms of other beneficial refinements.

On this double page you will see the choice of possible RKM configurations. Each of the versions illustrated is the result of a specific customized solution. In other words, these are not "off the shelf" products but have developed from specific requests from the mobile sector.

The result is a range with matchless flexibility and a wealth of ideas. Further details can be found in the current brochure no. 7.108.2.

Needless to say, with the varied RKM standard range as your starting point, there is always the option of developing new RKM solutions individually tailored to your application and requirement profile.

Please view this selection as a "appetizer" and let us know what solutions you are seeking.

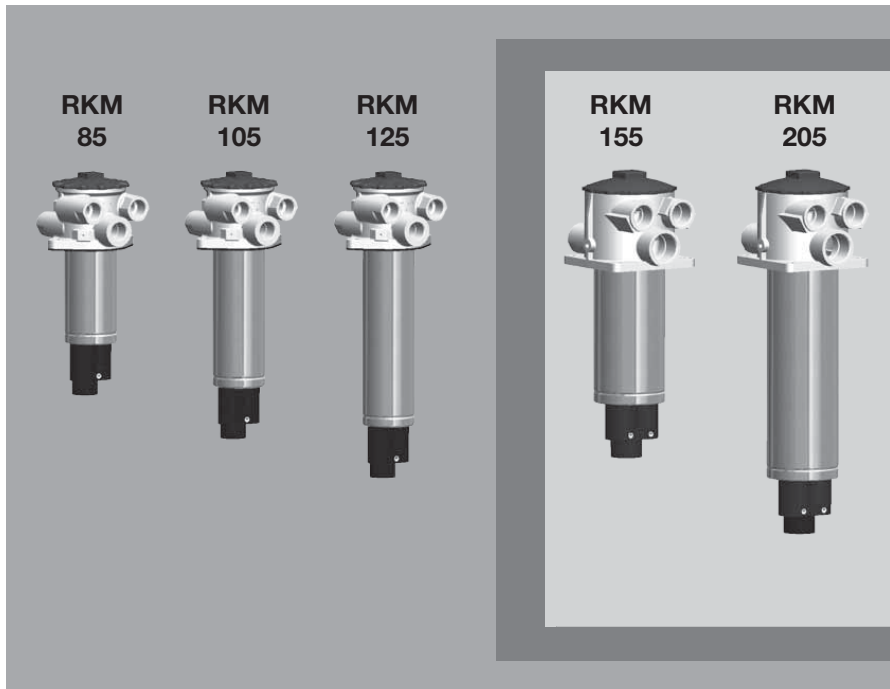

Head of RKM 85 - 125 Multiport.

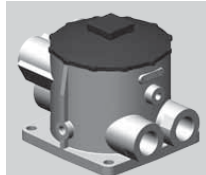

Head of RKM 155 - 255 Multiport.

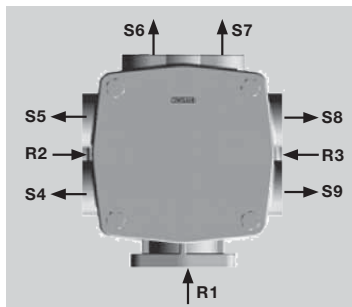

Variety of connections with RKM Multiport.

RKM 85 – 255 and 405 – 805 Variety of connections with "RKM Multiport".

Almost all RKM sizes are available with a Multiport filter head. The huge number of possible combinations of return line and suction boost connections and the different port positions means that the filter can be quickly configured to suit individual customers.

For sizes 405 and 805 there are for example nearly 200,000 (!) versions available (see table below).

Particular advantages of having variety of connections:

- Space and cost saving
- Reduction in components
Need for blocks, hoses and threaded connections is eliminated
- Reduced risk of leakage
- Great flexibility

Connection	Return lines			Suction lines					
	R1	R2	R3	S4	S5	S6	S7	S8	S9
SAE DN 50	✓	x	x	x	x	x	x	x	x
SAE DN 65	✓	x	x	x	x	x	x	x	x
G 1	x	✓	✓	✓	✓	✓	✓	✓	✓
G 1½	x	✓	✓	✓	✓	✓	✓	✓	✓
G 1½	x	✓	✓	✓	✓	✓	✓	✓	✓

Connection options for return lines and suction lines.

RKM 155 – 305 with Cost-Saving connection "CS".

The patented CS connection is designed to speed up and simplify the mounting of hoses by using just four screws supplied with the filter.

Particular advantages of this version:

- Simplified installation**
Whereas in the case of conventional SAE flanges four screws, four washers and two installation fittings are required per hose connection, the CS connection does not require any other additional installation fitting.
- Improved cold start performance**
compared to standard threaded connections, due to lower pressure drop on suction side.

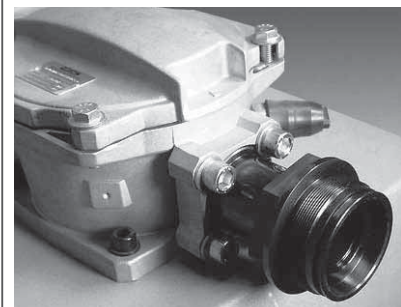

Advantageous Cost-Saving connection.

E 7.124.0/03.12

Optimized for efficiency. Quality protected.

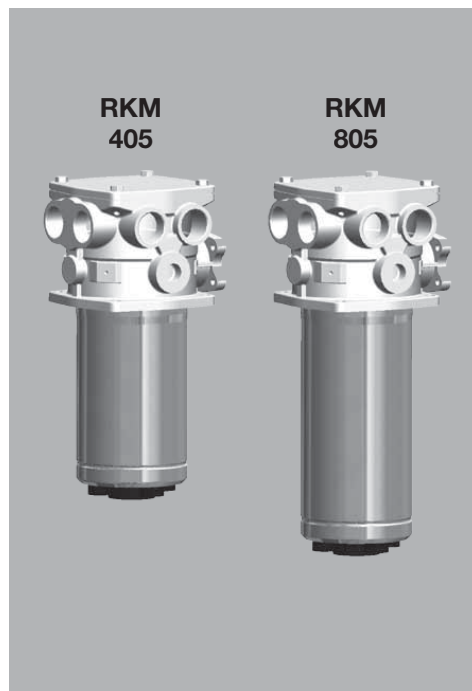
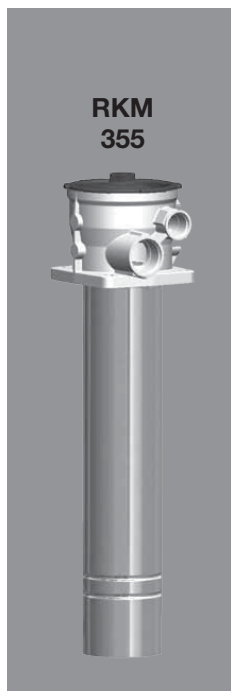
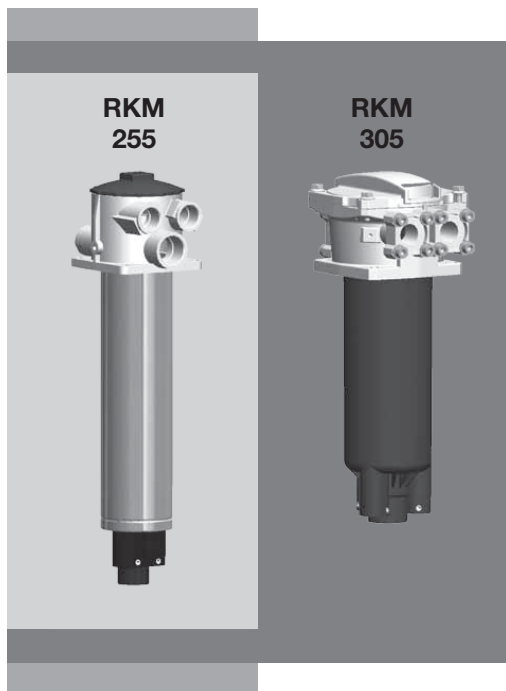

RKM 155 – 255 with thermal bypass valve

For the RKM 155 - 255, a temperature controlled cooler bypass valve can be built directly into the filter head, on request. This "intelligent" valve varies the volume of the fluid to be cooled depending on the temperature of the operating fluid.

Particular advantages of this version:

Enhanced protection of the shaft seals during cold start

because the built-in temperature-controlled valve provides huge savings in Δp , particularly compared to externally piped cooler bypass valves which use check valves. Also in comparison to externally piped thermal valves, significant improvements in Δp are achieved.

Drastically reduced time and effort for installation (Plug & Play),

because the complete package is supplied ready-to-install (reduction in components) and the need for blocks and fittings is largely eliminated.

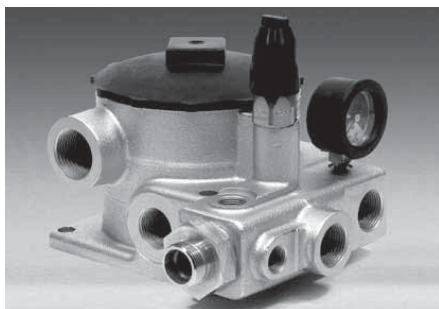

RKM head with built-in thermal bypass valve and numerous connection options (Multiport).

RKM 355 with cooler bypass valve.

The valve "V1" is used here as a cooler bypass valve.

It protects the cooler from excessive pressures. If the back pressure increases at the cooler during cold start, the valve opens and part of the flow drains directly to the tank.

In order to ensure full flow cooling, the element bypass valve discharges to the cooler.

Particular advantages of this version:

Space and cost saving

Cooler bypass valve built into the filter

Increased operating safety

Cooler always supplied with finely filtered oil

Pressure protection of the cooler

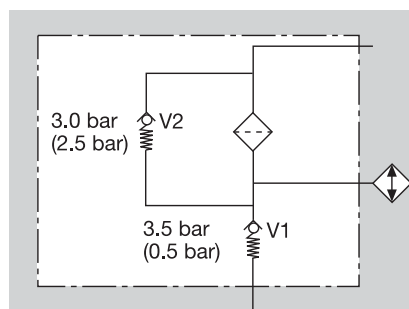

Function of the RKM 355 with cooler bypass valve.

E 7.124.0/03.12

HYDAC RKM: Two Filters in One.

A design that saves money.

By using a HYDAC Return Line & Suction Boost Filter RKM you will benefit from:

Space saving

Just one filter required instead of two

Easy maintenance

Half the time required for installation and maintenance

Cost saving

Lower investment, storage and service costs

Increased operating safety

Cavitation at the pump is reliably prevented and finely filtered oil is supplied even in the suction line.

One filter.

Two functions.

All the advantages.

The RKM combines the advantages of a return line filter with those of a suction filter in a single filter!

Return line & suction boost filters are particularly suitable for use in machines with two or more circuits, such as for example in mobile working machines with hydrostatic traction drives (wheel loaders, forklifts).

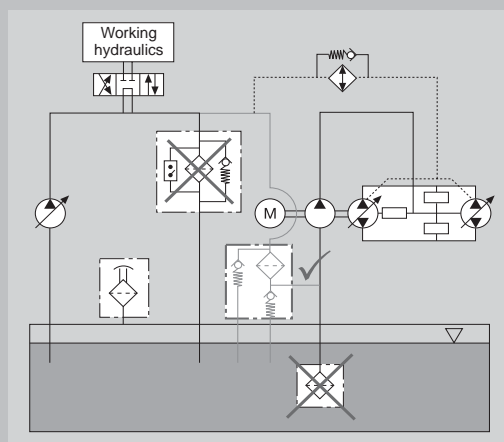
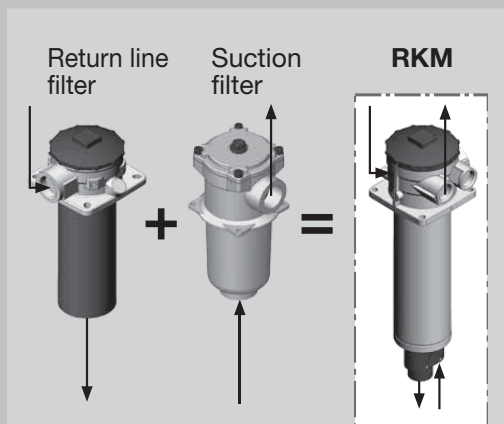

Application example for the RKM in mobile machines.

Function.

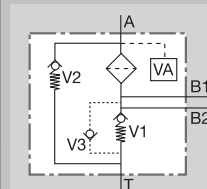

The return line flow Q_R is supplied to the element via one or more inlets "A". Once the element has been subjected to flow from the outside to the inside, the back-pressure valve "V1" in the element builds 0.5 bar positive pressure. Particularly in cold start this positive pressure supports the suction characteristics of the pump(s) connected to "B" (e.g. boost pumps). This considerably reduces the risk of cavitation.

The surplus volume drains directly to tank, bypassing the element. This configuration of valves ensures that only finely filtered oil reaches the suction port during operation*. The gradual increase of the valve characteristics contributes to keeping the back pressure in the return lines sufficiently low, even with high viscosity levels.

With optional valve "V3", oil can be drawn from the tank for short periods*, e.g. for initial filling and for venting.

Part of the flow then drains directly to tank, bypassing the element. This configuration of valves ensures that only finely filtered oil reaches the suction port during operation*. The gradual increase of the valve characteristics contributes to keeping the back pressure in the return lines sufficiently low, even with high viscosity levels.

With optional valve "V3", oil can be drawn from the tank for short periods*, e.g. for initial filling and for venting.

Further options:

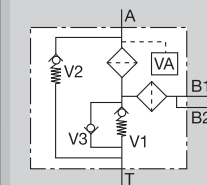

Anti-cavitation valve* with coarse filter strainer for filtered oil also in anti-cavitation mode

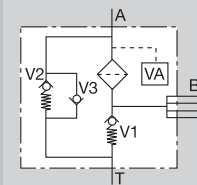

Anti-cavitation valve* in the element bypass valve "V2" for finely filtered oil also in anti-cavitation mode

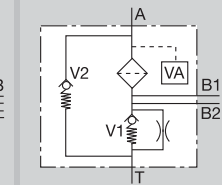

Throttle in back-pressure valve "V1" for reducing pressure and draining oil

* not for RKM 355
VA = clogging indicator

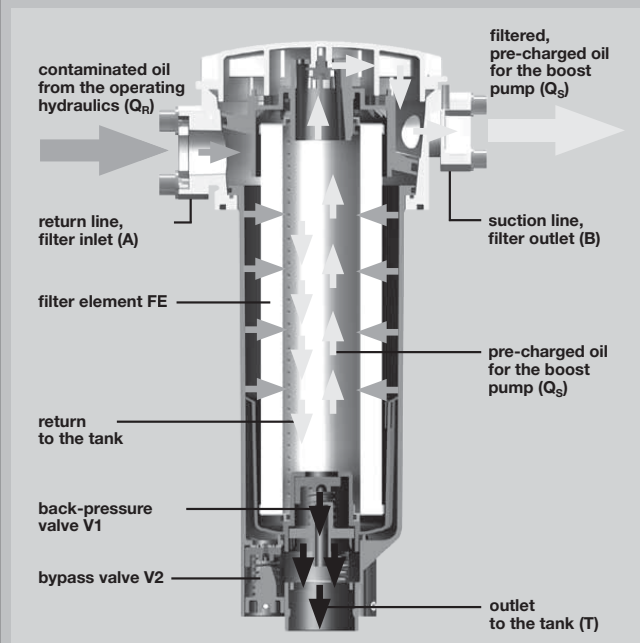

Function of the RKM.