



ROEMHELD
HILMA ■ STARK

Issue 3-00 E

F 9.290

Rotary Valve Coupling

nominal diameter 5
max. operating pressure 500 bar



Description

Rotary valve couplings are used if several fixtures have to be supplied on rotary indexing systems. Provided that clamping and unclamping will be made always in the same place and the fixtures are arranged in a uniform way on the rotating plate. Clamping and unclamping is made by 1 off - or in the case of double-acting cylinders by 2 off 2/2 directional control valves, which are arranged outside the rotating system. Since in the unclamped position there is a continuous leakage to the return line, we recommend to use an accumulator for applications with operation pressures of up to 200 bar, for applications with operating pressures exceeding 200 bar an accumulator is required.

Versions

Loading and unloading in one station
see page 2

Loading and unloading in two stations - commonly controlled, see page 3

Loading and unloading in two stations - separately controlled, see page 4

Important notes

Rotary valve coupling must only be operated with hydraulic oil.

The rotary coupling has to be connected to the power unit on all levels to ensure sufficient lubrications of the seals.

Order

When placing an order, please indicate the most important operating data (pressure, temperature, medium, number of revolutions or cycle time), in order to allow a possible adaptation from standard for the application.

Application examples

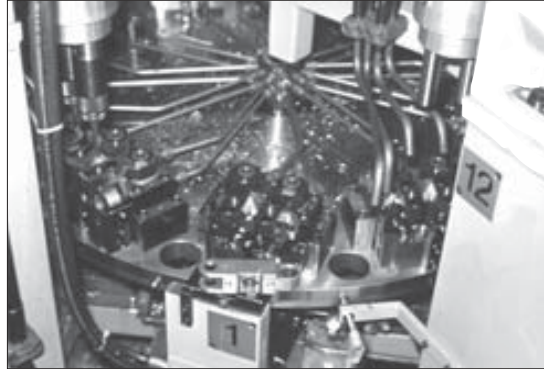

Rotary valve coupling at an indexing machine with 12 stations



Rotary valve coupling with 8 stations for single-acting swing clamps. Application in a multiple-spindle machine with four stations for machining of aluminium covers. The four not required ports of the rotary valve coupling are plugged.

Rotary valve coupling in combination with an automatic coupling system

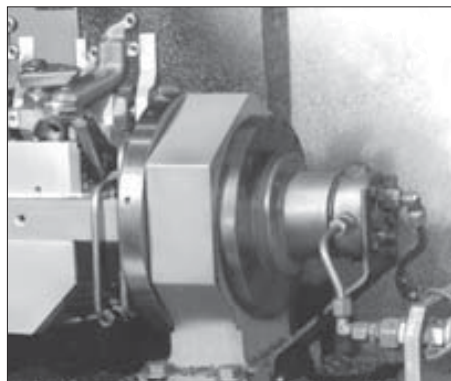
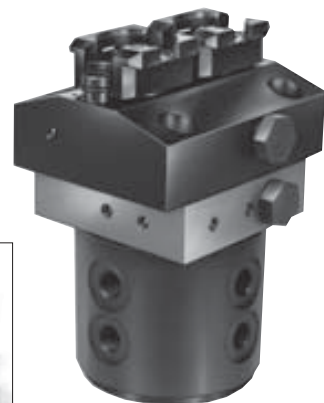

Trunnion bearing with hydraulic locking and integrated oil supply through rotary valve coupling

Loading and unloading in one station

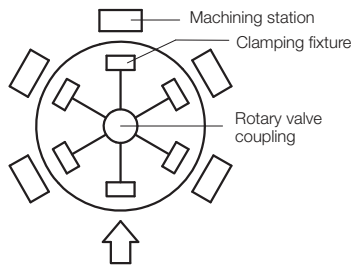

Loading and unloading station

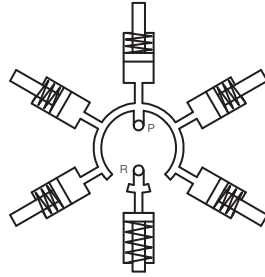

| Number of stations | Part no. single-acting cylinders | Part no. double-acting cylinders |
|--------------------|----------------------------------|----------------------------------|
| 5 | 9295-001 | 9295-002 |
| 6 | 9296-001 | 9296-002 |
| 7 | 9297-001 | 9297-002 |
| 8 | 9298-001 | 9298-002 |
| 9 | 9299-001 | 9299-002 |
| 10 | 9290-001 | 9290-002 |

Special versions on request

Rotary valve coupling for single-acting cylinders

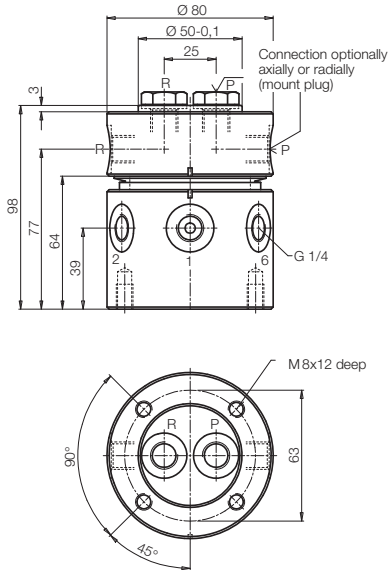

Circuit example – 6 stations

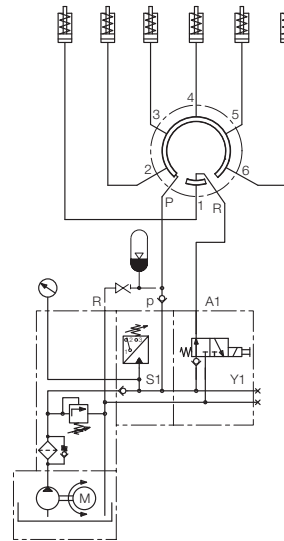

Rotary valve coupling for double-acting cylinders

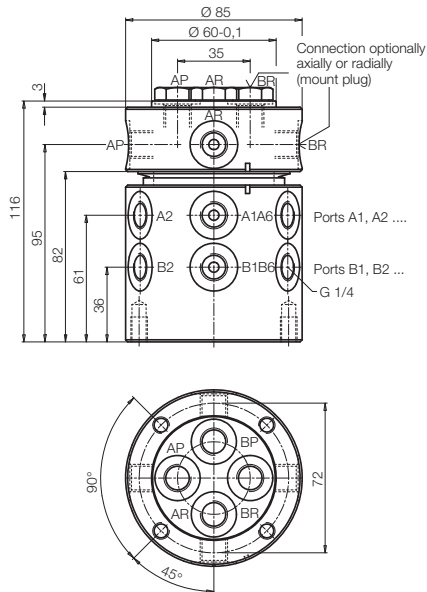

Circuit example – 6 stations

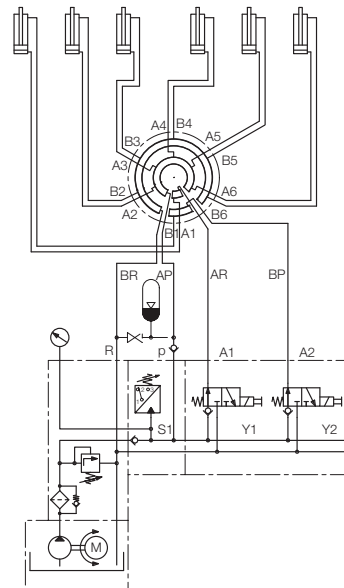

Loading and unloading in two stations • commonly controlled

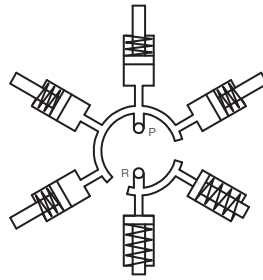
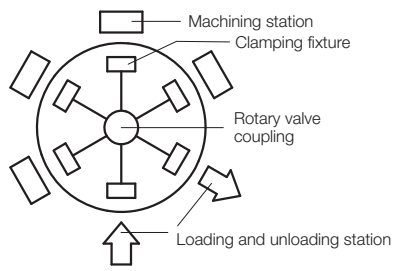

| Number of stations | Part no. single-acting cylinders | Part no. double-acting cylinders |
|--------------------|----------------------------------|----------------------------------|
| 6 | 9296-011 | 9296-012 |
| 8 | 9298-011 | 9298-012 |
| 10 | 9290-011 | 9290-012 |

Special versions on request

Rotary valve coupling for single-acting cylinders

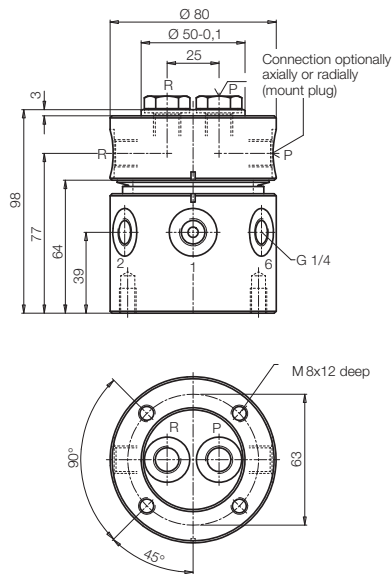

Circuit example – 6 stations

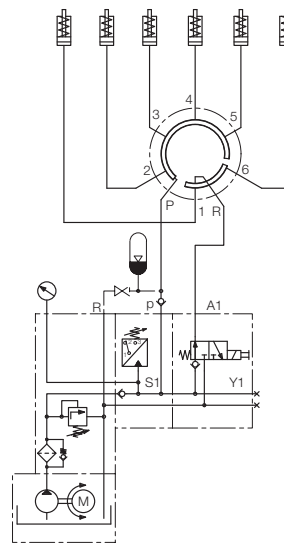

Rotary valve coupling for double-acting cylinders

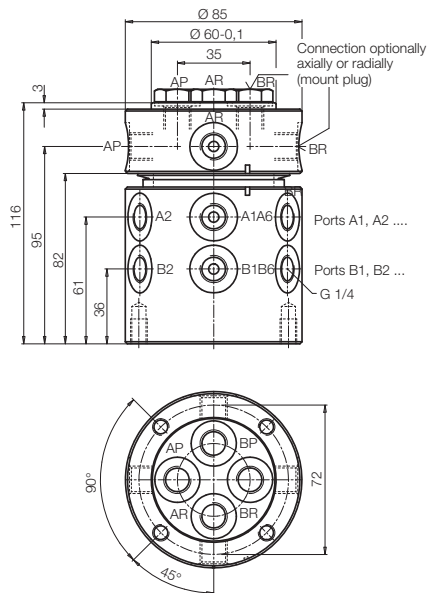

Circuit example – 6 stations

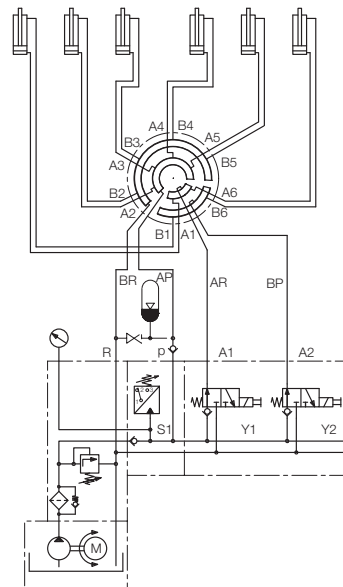

Loading and unloading in two stations • separately controlled

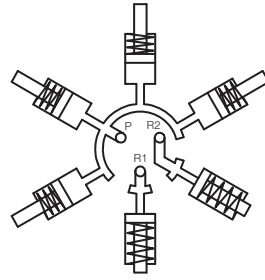
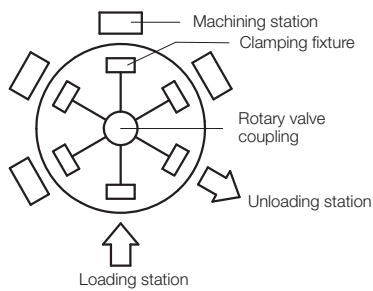

| Number of stations | Part no. single-acting cylinders | Part no. double-acting cylinders |
|--------------------|----------------------------------|----------------------------------|
| 6 | 9296-101 | 9296-102 |
| 8 | 9298-101 | 9298-102 |
| 10 | 9290-101 | 9290-102 |

Special versions on request

Rotary valve coupling for single-acting cylinders

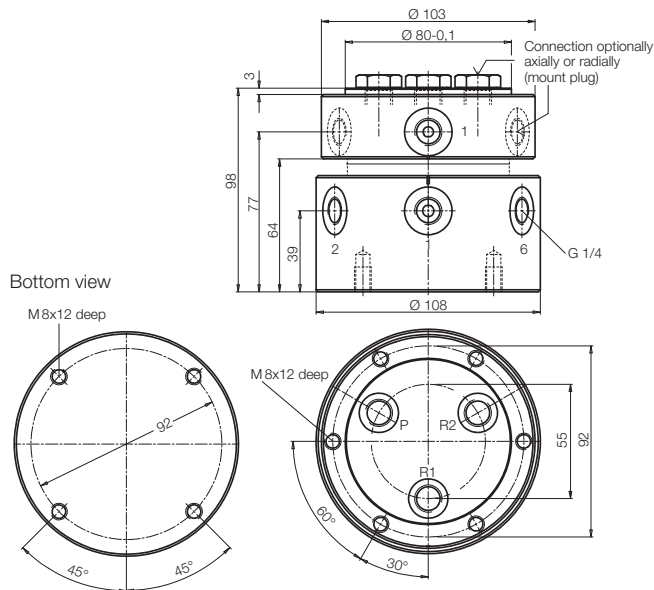

Circuit example – 6 stations

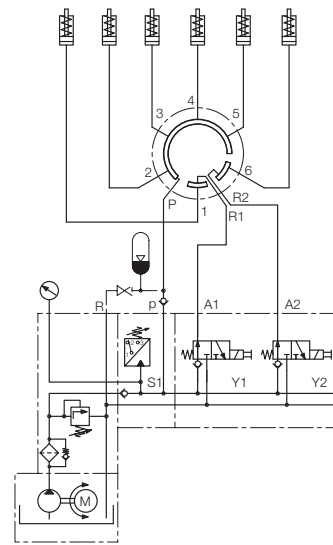

Rotary valve coupling for double-acting cylinders

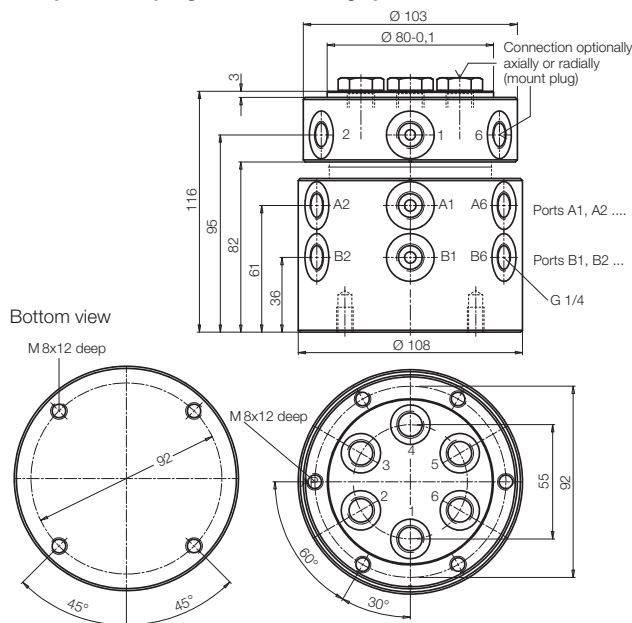

Circuit example – 6 stations

