

Electric Drives
and Controls

Hydraulics

Linear Motion and
Assembly Technologies

Pneumatics

Service

Rexroth
Bosch Group

4/4-way servo solenoid directional control valves, directly operated, with electrical position feedback and on-board electronics (OBE)

RE 29035/10.10 1/12
Replaces: 05.10

Type 4WRPEH6

Size 6
Unit series 2X
Maximum working pressure P, A, B 315 bar, T 250 bar
Nominal flow 2...40 l/min (Δp 70 bar)

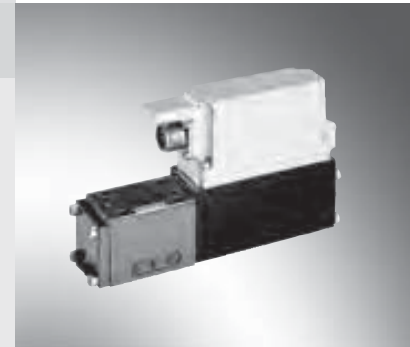

Type 4WRPEH6

List of contents

Contents	Page
Features	1
Ordering data	2
Function, sectional diagram	3
Symbols	3
Testing and service equipment	3
Technical Data	4 and 5
Electric connection	6
Technical notes on the cable	6
On-board electronics	7 and 8
Characteristic curves	9 and 10
Unit dimensions	11

Features

- Directly operated servo solenoid directional control valve, with control piston and sleeve in servo quality
- Actuated on one side, 4/4 fail-safe position when switched off
- Electrical position feedback and on-board electronics (OBE), calibrated at the factory
- Electrical connection 6P+PE
Signal input differential amplifier with interface A1 ± 10 V or interface F1 4...20 mA ($R_{sh} = 200 \Omega$)
- Used in electrohydraulic controllers in production and testing systems

Ordering data

4WRP E H 6 B -2X/G24 K0/ M *

With on-board electronics = E

Control piston/sleeve = H

Size = 6

Control spool symbols

4/4-way version

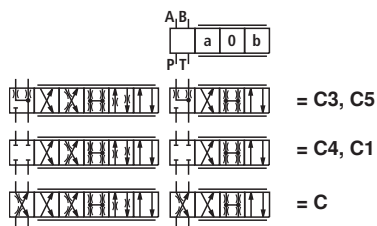

With C5 and C1: ³⁾

P → A: Q_v B → T: $Q_v/2$

P → B: $Q_v/2$ A → T: Q_v

Assembly side of inductive position transducer

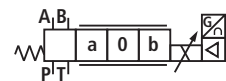

(Standard) = B

¹⁾ Only in connection with flow characteristic "P"

²⁾ Kink 60% for NG6 with nominal flow rate "15" and "25", otherwise kink 40%

³⁾ Q_v 2:1 only with nominal flow rate = 40 l/min

⁴⁾ Not in connection with flow characteristic "P"

⁵⁾ Only in connection with flow characteristic "L"

Further information in plain text

Seal material

NBR seals, suitable for mineral oils (HL, HLP) to DIN 51524

Interface for trigger electronics

A1 = Setpoint input ±10 V
F1 = Setpoint input 4...20 mA

Electrical connection

K0 = without plug-in connector, with plug to DIN 43563-AM6
Order plug-in connector separately

Voltage supply of trigger electronics

G24 = +24 V DC

2X = Unit series 20 to 29 (installation and connection dimensions unchanged)

Flow characteristic

L = Linear
P = Non-linear curve²⁾

Nominal flow rate

at 70 bar valve pressure difference (35 bar per metering notch)

02 =	2 l/min ⁴⁾
04 =	4 l/min
12 =	12 l/min ⁵⁾
15 =	15 l/min ¹⁾
24 =	24 l/min ⁵⁾
25 =	25 l/min ¹⁾
40 =	40 l/min ³⁾

Function, sectional diagram

General

In the field of integrated electronics, the specified command value is compared with the actual position value. In case of deviations from the standard, the lifting solenoid is activated. Due to the changed magnetic force, the lifting solenoid adjusts the control valve against the spring.

Lifting/control cross-section are adjusted proportionally to the command value. In case of a command value provision of 0 V, the electronics adjusts the control valve against the spring to center position. In deactivated condition, the spring is unloaded to a maximum and the valve is in fail-safe position.

Switch-off behavior

If the electronics is switched off, the valve immediately moves to the secured basic position (fail safe).

In this process, the P-B/A-T position is passed which might cause movements at the controlled component. This must be taken into account when designing the plant.

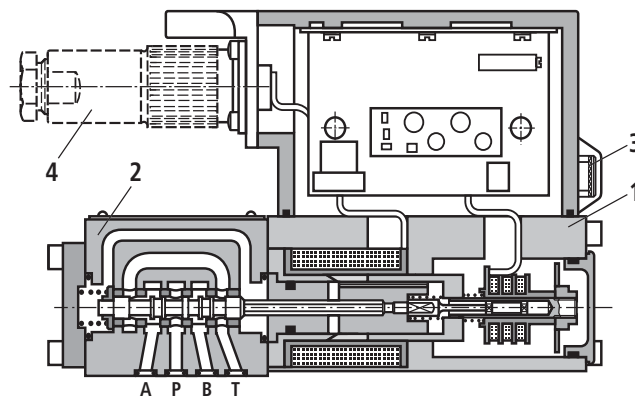

- 1 Control solenoid with position transducer
- 2 Valve body
- 3 Plug for possible 2nd stage
- 4 Plug in connector

Symbols

	L: Linear	P: kink

Testing and service equipment

- Service case type VT-VETSY-1 with test device, see data sheet 29685
- Measuring adapter 6P+PE type VT-PA-2, see data sheet 30068

Technical data

General

Construction	Spool-type valve, directly operated, with steel sleeve	
Actuation	Control solenoid with position control, OBE	
Type of mounting	Subplate, mounting hole configuration (ISO 4401-03-02-0-05)	
Installation position	Optional	
Ambient temperature range	°C	-20...+50
Weight	kg	2.7
Vibration resistance, test condition	Max. 25 g, shaken in 3 dimensions (24 h)	

Hydraulic (measured with HLP 46, $\vartheta_{oil} = 40\text{ °C} \pm 5\text{ °C}$)

Pressure fluid	Hydraulic oil to DIN 51524...535, other fluids after prior consultation							
Viscosity range	recommended	mm ² /s	20...100					
	max. permitted	mm ² /s	10...800					
Pressure fluid temperature range	°C	-20...+70						
Maximum permissible degree of contamination of pressure fluid Purity class to ISO 4406 (c)	Class 18/16/13 ¹⁾							
Direction of flow	See symbol							
Nominal flow at $\Delta p = 35\text{ bar}$ per notch ²⁾	l/min	2	4	12	15	24	40	
Max. working pressure	Ports P, A, B	bar 315						
	Port T	bar 250						
Operating limits at Δp								
Pressure drop at valve	C, C3, C5	bar	315	315	315	315	315	160
$Q_{Vnom} > Q_N$ valves	C4, C1	bar	315	315	315	280	250	100
Max. recommended nominal flow at 100 bar	Linear characteristic curve L	cm ³ /min	< 150	< 180	< 300	-	< 500	< 900
	Inflected characteristic curve P	cm ³ /min	-	-	-	< 180	< 300	< 450

Fail-safe position

C							
Flow at $\Delta p = 35\text{ bar}$ per notch	l/min	2	4	10	13	18	20
C3, C5	cm ³ /min	50 P-A					
Zero flow at 100 bar	cm ³ /min	70 P-B					
C3, C5	l/min	10...20 A-T					
Flow at $\Delta p = 35\text{ bar}$ per notch	l/min	7...20 B-T					
C4, C1	cm ³ /min	50 P-A					
Zero flow at 100 bar	cm ³ /min	70 P-B					
	cm ³ /min	70 A-T					
	cm ³ /min	50 B-T					
	cm ³ /min	70 B-T					
Fail-safe position reached	0 bar	7 ms					
	100 bar	10 ms					

Static/Dynamic

Hysteresis	%	≤ 0.2
Manufacturing tolerance for Q_{max}	%	< 10
Response time for signal change 0...100%	ms	≤ 10
Thermal drift	Zero point displacement < 1% at $\Delta T = 40\text{ °C}$	
Zero adjustment	Factory-set ± 1%	

¹⁾ The purity classes stated for the components must be complied with in hydraulic systems. Effective filtration prevents problems and also extends the service life of components. For a selection of filters, see www.boschrexroth.com/filter.

²⁾ Flow rate at a different Δp $Q_x = Q_{nom} \cdot \sqrt{\frac{\Delta p_x}{35}}$

Technical data

Electrical, trigger electronics integrated in the valve

Cyclic duration factor	%	100
Degree of protection		IP 65 to EN 60529 and IEC 14434/5
Connection		Plug-in connector 6P+PE, DIN 43563
Power supply		24 V DC _{nom}
Terminal A:		Min. 21 V DC/max. 40 V DC
Terminal B: 0 V		Ripple max. 2 V DC
Max. power consumption		40 VA
External fuse		2.5 A _F
Input, version A1		Differential amplifier, R _i = 100 kΩ
Terminal D: U _E		0...±10 V
Terminal E:		0 V
Input, version F1		Burden, R _{sh} = 200 Ω
Terminal D: I _{D-E}		4...(12)...20 mA
Terminal E: I _{D-E}		Current loop I _{D-E} feedback
Max. differential input voltage at 0 V		D → B } max. 18 V= E → B }
Test signal, version A1		LVDT
Terminal F: U _{Test}		0...+10 V
Terminal C:		Reference 0 V
Test signal, version F1		LVDT signal 4...20 mA at external load 200...500 Ω max.
Terminal F: I _{F-C}		4...20 mA output
Terminal C: I _{F-C}		Current loop I _{F-C} feedback
Protective conductor and screen		See pin assignment (CE-compliant installation)
Calibration		Calibrated at the factory, see characteristic curve of the valve
Electromagnetic compatibility tested according to		EN 61000-6-2: 2005-08 EN 61000-6-3: 2007-01

Version A1: Standard

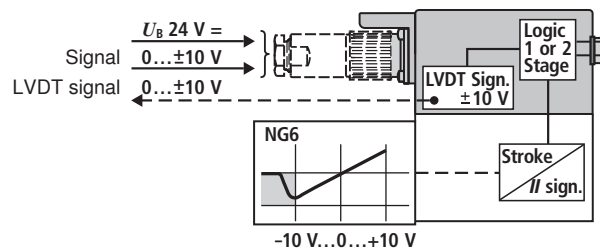

Version F1: mA signal

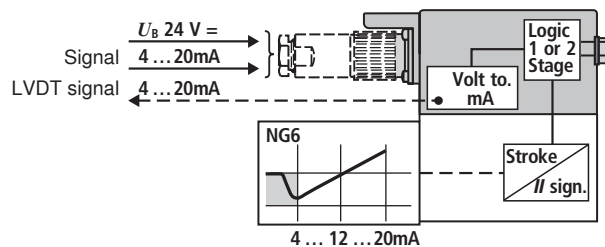

Electric connection

For electrical data, see page 5

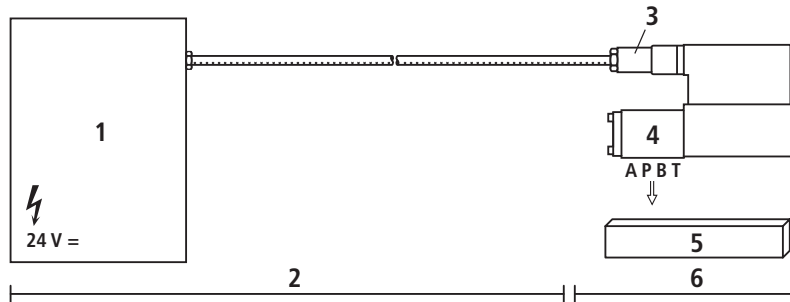

- 1 Control
- 2 Provided by customer
- 3 Plug-in connector
- 4 Valve
- 5 Connecting surface
- 6 Provided by Rexroth

Technical notes on the cable

- Version:**
- Multi-wire cable
 - Extra-finely stranded wire to VDE 0295, Class 6
 - Protective conductor, green/yellow
 - Cu braided screen
- Types:**
- e.g. Ölflex-FD 855 CP (from Lappkabel company)
- No. of wires:**
- Determined by type of valve, plug types and signal assignment
- Cable Ø:**
- 0.75 mm² to 20 m length
 - 1.0 mm² to 40 m length
- Outside Ø:**
- 9.4...11.8 mm – Pg11
 - 12.7...13.5 mm – Pg16

Note

Voltage supply 24 V DC_{nom}, if voltage drops below 18 V DC, rapid shutdown resembling "Enable OFF" takes place internally.

In addition, with F1 version:

$I_{D-E} \cong 3 \text{ mA}$ – valve is active

$I_{D-E} \cong 2 \text{ mA}$ – valve is deactivated.

Electrical signals emitted via the trigger electronics (e.g. actual values) must not be used to shut down safety-relevant machine functions! (See European Standard, "Technical Safety Requirements for Fluid-Powered Systems and Components – Hydraulics", EN 982.)

On-board electronics

Block diagram/pin assignment

Version A1: $U_{D-E} \pm 10\text{ V}$

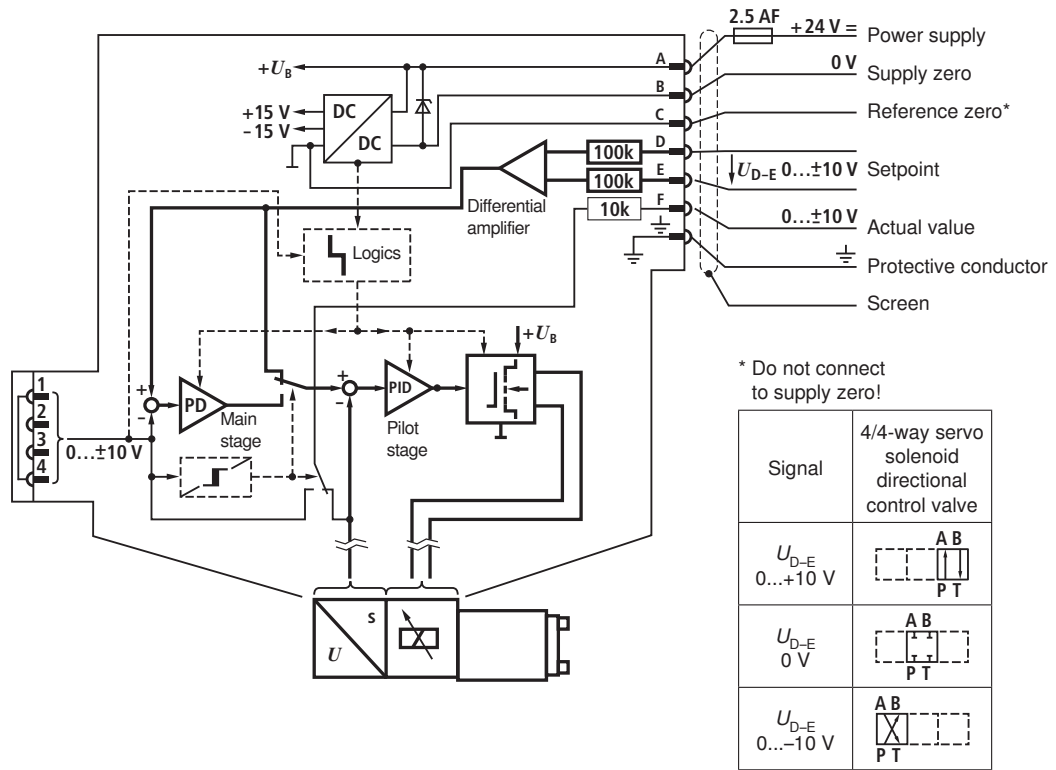

Pin assignment 6P+PE

Version A1: $U_{D-E} \pm 10\text{ V}$

($R_i = 100\text{ k}\Omega$)

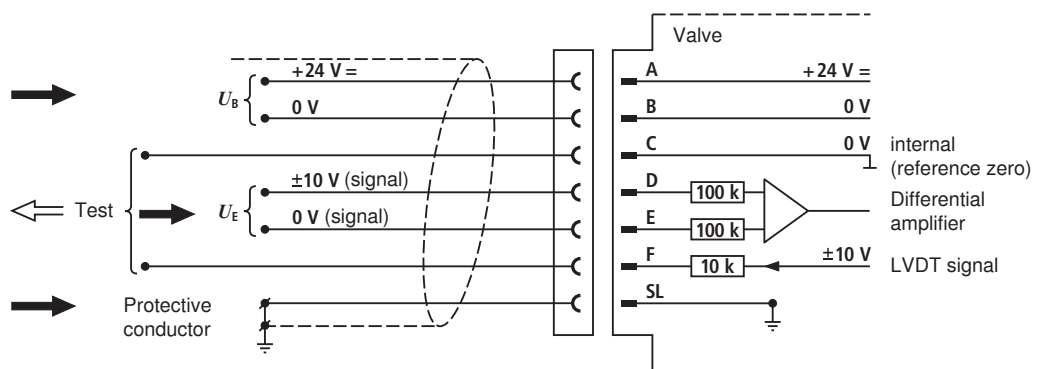

On-board electronics

Block diagram/pin assignment

Version F1: I_{D-E} 4...12...20 mA

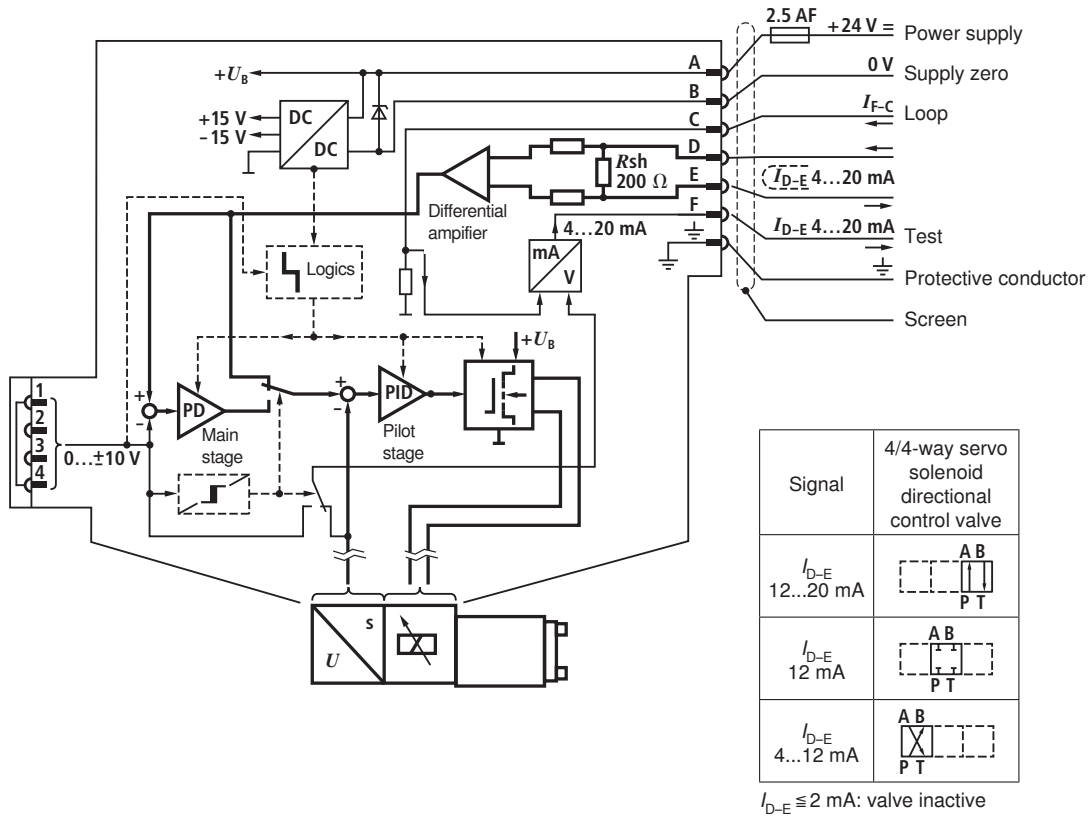

Pin assignment 6P+PE

Version F1: I_{D-E} 4...12...20 mA
($R_{sh} = 200 \Omega$)

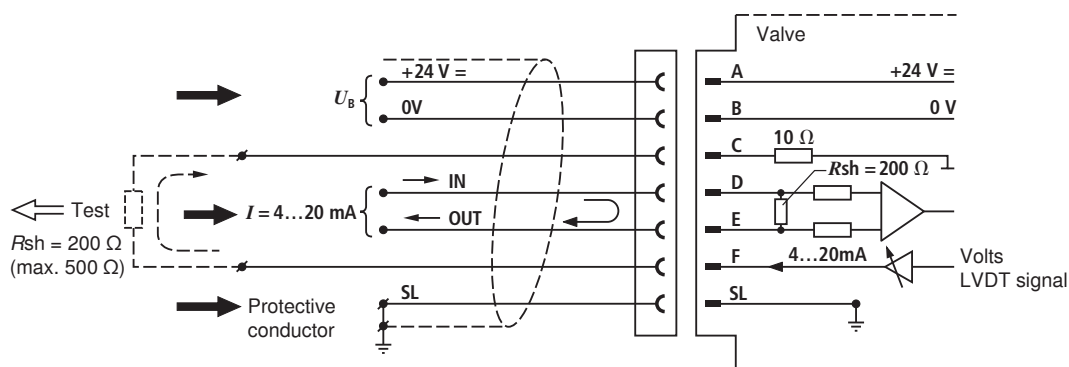

Characteristic curves (measured with HLP 46, $\vartheta_{oil} = 40^\circ\text{C} \pm 5^\circ\text{C}$)

Flow rate – signal function $Q = f(U_{D-E})$
 $Q = f(I_{D-E})$

Flow characteristic
 L: Linear

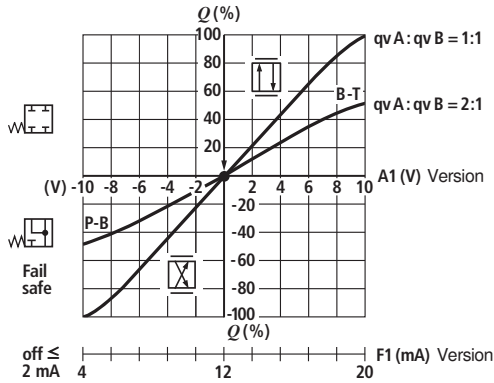

Flow characteristic
 P: (kink 60%) 15 l/min

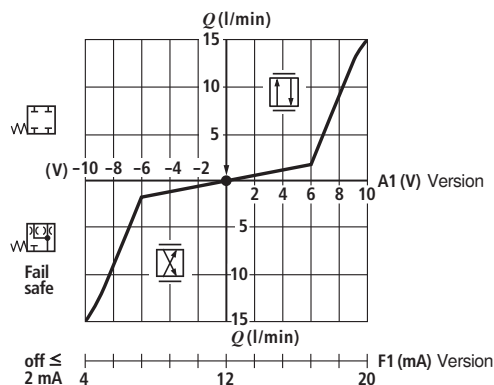

Flow characteristic
 P: (kink 60%) 25 l/min

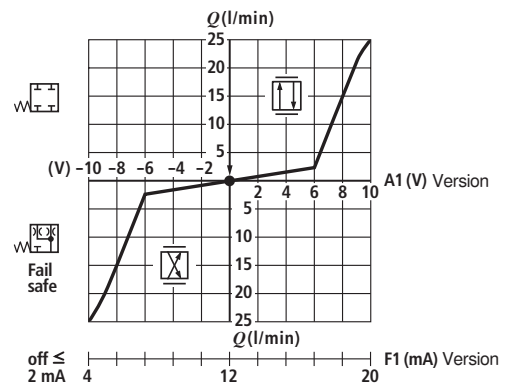

Flow characteristic
 P: (kink 40%) 40 l/min

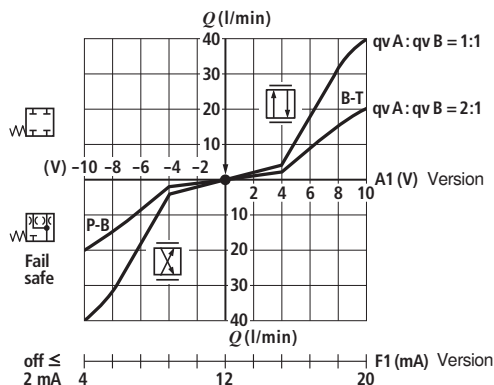

Characteristic curves (measured with HLP 46, $\vartheta_{oil} = 40\text{ }^\circ\text{C} \pm 5\text{ }^\circ\text{C}$)

Pressure gain

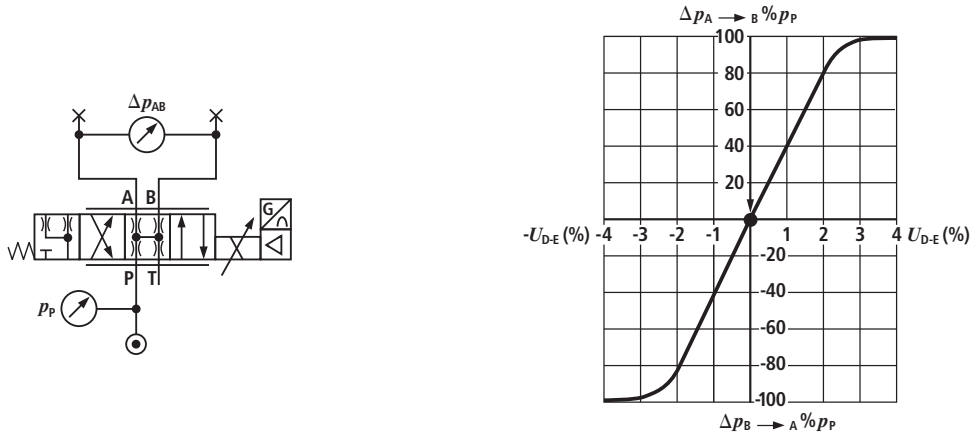

Bode diagram

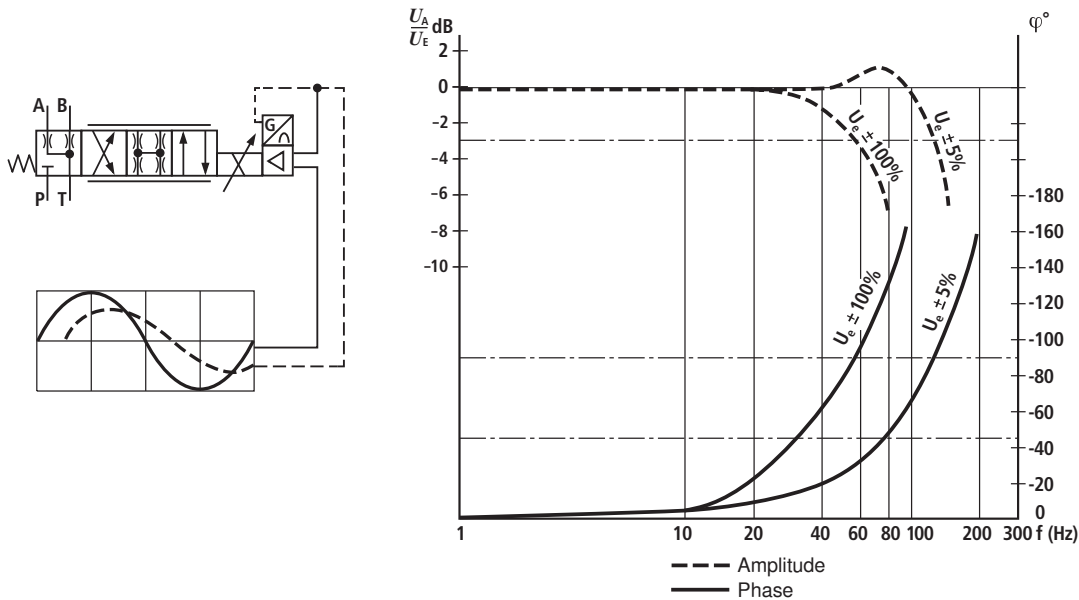

RE 29035/10.10 | 4WRPEH6

Hydraulics | Bosch Rexroth AG 11/12

Unit dimensions (dimensions in mm)

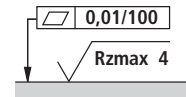
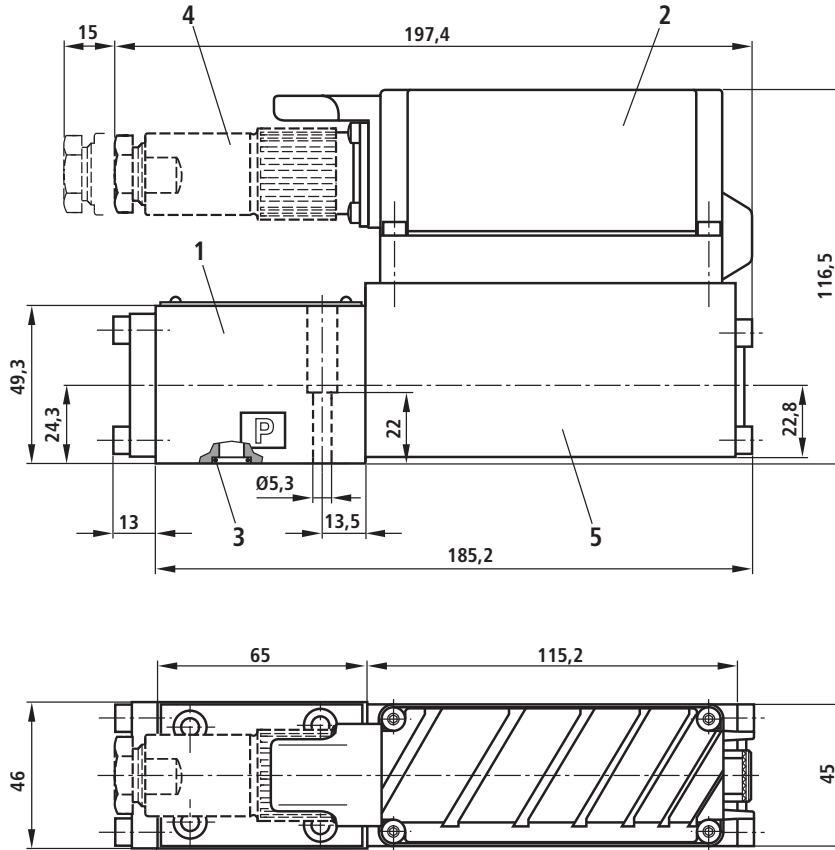

Required surface quality
of valve mounting face

- 1 Valve housing
 - 2 On-board electronics
 - 3 O-rings $\varnothing 9.25 \times 1.78$ (ports P, A, B, T)
 - 4 Plug-in connector not included in scope of delivery, see data sheet 08008 (order separately)
 - 5 Control solenoid with position transducer
 - 6 Machined valve contact surface, mounting hole configuration to ISO 4401-03-02-0-05
Deviates from standard:
Ports P, A, B, T $\varnothing 8$ mm
Minimum thread depth: Ferrous metal $1.5 \times \varnothing$
Non-ferrous $2 \times \varnothing$
- Subplates**, see data sheet 45053 (order separately)

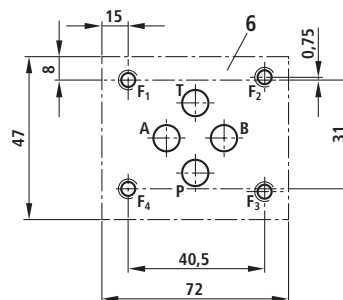

Valve fastening bolts (order separately)

The following valve fastening bolts are recommended:

4 cheese-head bolts ISO 4762-M5x30-10.9-N67F82170
(galvanized in accordance with Bosch standard N67F82170)
Tightening torque $M_A = 6 \pm 2$ Nm
Material no. **2910151166**

or
4 cheese-head bolts ISO 4762-M5x30-10.9
(coefficient of friction $\mu_{\text{total}} = 0.12-0.17$)
Tightening torque $M_A = 8.9$ Nm $\pm 10\%$

Notes

© This document, as well as the data, specifications and other information set forth in it, are the exclusive property of Bosch Rexroth AG. It may not be reproduced or given to third parties without its consent.
The data specified above only serve to describe the product. No statements concerning a certain condition or suitability for a certain application can be derived from our information. The information given does not release the user from the obligation of own judgment and verification. It must be remembered that our products are subject to a natural process of wear and aging.