

Electric Drives
and Controls

Hydraulics

Linear Motion and
Assembly Technologies

Pneumatics

Service

Rexroth
Bosch Group

Clamping and drive module

RE 51142/05.13
Replaces: 02.11

1/10

Type UPE 2

Drive power 1.1 kW / 2.2 kW
Component series 1X
Maximum operating pressure 700 bar



UPE2_1X**

Table of contents

Contents	Page
Features	1
Applications	1
Description	2
Symbol	2
Ordering code	2
Overview of the attachment modules	3
Technical data	4
Performance diagram	4
Electric motor	5
• Technical data	5
• Electromagnetic compatibility of devices (EMVG)	5
• Terminal assignment	5
Dimensions	6
Filling and removal quantity	6
Sound pressure level	7
Options	7
• Level switch, electrical function	8
• Temperature switch, electrical function	8
• Ventilation filter	8
• Oil tray	8
Commissioning notes	9

Features

- Duty cycle, short-time operation S2 and intermittent operation S3
- Compact design
- Low-noise
- Broad field of application
- Large number of variants
- Complete hydraulic control possible
(in this connection see data sheet 51144)
- Ready for connection

Applications

- Clamping, locking, releasing and indexing at machines
- Drive for hydraulic tools
- Drive for lifting and swiveling units
- Use in the general mechanical engineering sector
- Test machines and test stands

Description, symbol

The UPE 2 clamping and drive module constitutes a complete drive system that is delivered ready for connection. It is used for supplying hydraulic circuits with hydraulic fluid.

For reasons in connection with the thermal load, the clamping and drive module is to be operated in short-time operation and intermittent operation. The duty cycle is to be selected depending on the power output and the environmental conditions so that the maximum admissible operating temperature of 80 °C is not exceeded.

The clamping and drive module basically consists of the aluminum housing, the pump (radial piston pump or external gear pump) and the oil-immersed motor. The stator of the oil-immersed motor is pressed into the aluminum housing. It transfers the heat of the winding directly to the exterior aluminum housing wall.

- For the installation, four through holes have been provided in the tank bottom for the mounting screws. The clamping and drive module is to be operated in vertical installation position.

Optionally, the UPE 2 clamping and drive module can be equipped with an electric monitor for the oil level as well as the oil temperature, a ventilation filter and a complete hydraulic control (see 51144).

⚠ Attention!

The clamping and drive module may heat up during operation => **risk of injury!**

Symbol

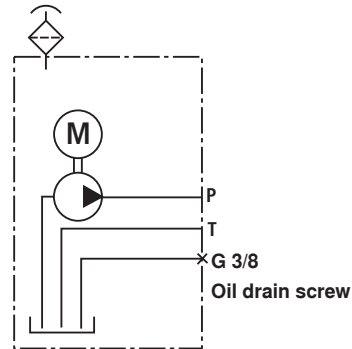

Ordering code

UPE 2-1X/ / / - / / V *		
Component series 10 to 19 (10 to 19: unchanged installation and connection dimensions)	= 1X	Further details in the plain text
Drive power		Seal
1.1 kW	= 1.1	V = FKM seals
2.2 kW	= 2.2	Mounting hydraulic control (in this connection see data sheet 51144)
Radial piston pump		0 = without mounting
Flow		1 = with mounting
0.49 liters/min	= R0.49	Carrying handle
0.82 liters/min	= R0.82	no code = without carrying handle
1.00 liter/min	= R1.00	T = with carrying handle
1.25 liters/min	= R1.25	Filling plug
1.70 liters/min	= R1.70	no code = Filler neck with dipstick
1.95 liters/min	= R1.95	B = Ventilation filter
2.55 liters/min	= R2.55	Oil monitoring
2.60 liters/min	= R2.60	A = Oil level display
4.00 liters/min	= R4.00	AN = Oil level display with level switch
External gear pump		AT = Oil level display and temperature switch
Flow		ANT = Oil level display with level and temperature switch
1.4 liters/min	= G1.40	Nominal tank size
2.8 liters/min	= G2.80	1.1 kW drive power
4.4 liters/min	= G4.40	Filling quantity 2.4 liters
5.6 liters/min	= G5.60	Filling quantity 4.5 liters
7.0 liters/min	= G7.00	2.2 kW drive power
8.8 liters/min	= G8.80	Filling quantity 4.3 liters
11.2 liters/min	= G11.2	Filling quantity 7.2 liters
14.0 liters/min	= G14.0	
3 = ¹⁾		
4 =		
5 = ¹⁾		
7 =		

¹⁾ Version with external gear pump not possible!

Overview of the attachment modules



UPE2_G+

Basic module "G"

Basic module "G"

- Basic module with integrated pressure relief valve for simple stroke lowering or pressure holding functions
- If the "G" basic modules are used, no further stacking is possible.
- For further details see data sheet 51144
"Control block for clamping and drive modules type IH15A"

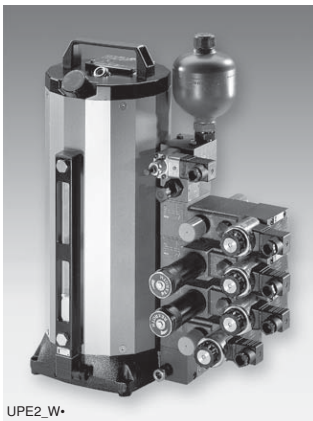

UPE2_W

Directional valve module "W"

Directional valve module "W" ¹⁾

- Allows the design of controls using valves with porting pattern according to DIN 24340 form A
- The number of directional valve modules depends on the draw-off volume and the displacement of the pump
- For further details see data sheet 51144
"Control block for clamping and drive modules type IH15A"

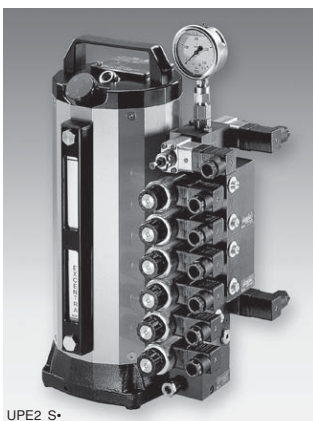

UPE2_S

Seat valve module "S"

Seat valve module "S" ¹⁾

- Seat valves basically consist of:
 - a pressure relief block
 - one or several control blocks
 - one end block
- The control is designed depending on the relevant application
- The number of seat valve modules depends on the draw-off volume and the displacement of the pump
- For further details see data sheet 51144
"Control block for clamping and drive modules type IH15A"

¹⁾ The directional valve modules and the seat valve modules can be combined!

Technical Data (For applications outside these parameters, please consult us!)

Hydraulic fluid	Mineral oil (HLP) according to DIN 51524, part 2 Please observe our specifications according to data sheet 07075!										
Hydraulic fluid temperature range °C	-20 to +80										
Maximum permitted degree of contamination of the hydraulic fluid cleanliness class according to ISO 4406 (c)	Class 20/18/15 ⁴⁾										
Optimum viscosity range mm ² /s	10 to 200										
Direction of rotation	Optional (radial piston pump), clockwise (external gear pump)										
Installation position	Vertical										
Mode of operation	All modes of operations in which the steady-state oil temperature remains below 80 °C.										
Radial piston pump											
Flow ³⁾	q_v in l/min	0.49	0.82	1.00 ²⁾	1.25	1.70 ²⁾	1.95	2.55 ²⁾	2.60	4.00 ²⁾	
Drive power	Speed ³⁾	n in min ⁻¹	1380	1380	2820	1380	2820	1380	2820	1380	2820
1.1 kW ¹⁾	Nominal pressure ³⁾	p_{max} in bar	700	700	700	450	310	250	200	180	140
	Speed ³⁾	n in min ⁻¹	1400	1400	2890	1400	2890	1400	2890	1400	2890
2.2 kW ¹⁾	Nominal pressure ³⁾	p_{max} in bar	700	700	700	450	700	350	450	250	280
	Speed ³⁾	n in min ⁻¹	1400	1400	2890	1400	2890	1400	2890	1400	2890
External gear pump											
Flow ³⁾	q_v in l/min	1.40	2.80	4.40	5.60	7.00	8.80	11.2 ²⁾	14.0 ²⁾		
Drive power	Speed ³⁾	n in min ⁻¹	1380	1380	1380	1380	1380	1380	2820	2820	
1.1 kW ¹⁾	Nominal pressure ³⁾	p_{max} in bar	260	180	140	110	90	70	45	37	
	Speed ³⁾	n in min ⁻¹	1400	1400	1400	1400	1400	1400	2890	2890	
2.2 kW ¹⁾	Nominal pressure ³⁾	p_{max} in bar	260	260	260	220	170	140	110	85	
	Speed ³⁾	n in min ⁻¹	1400	1400	2890	1400	2890	1400	2890	1400	2890
Protection class according to VDE 0530 / EN 60034			IP 54 with power unit completely mounted								
Nominal tank size / type			3/R	4/R	4/G	5/R	7/R	7/G			
Weight (without hydraulic fluid) kg			17.8	18.4	19.6	23.0	25.0	26.6			

¹⁾ See the following performance diagram

²⁾ 60 Hz is not possible!

³⁾ Referred to the speed at 50 Hz

⁴⁾ The cleanliness classes specified for the components must be adhered to in hydraulic systems. Effective filtration prevents faults and at the same time increases the service life of the components.

For selecting the filters, see data sheet 51144.

Performance diagram ⁵⁾

Radial piston pump

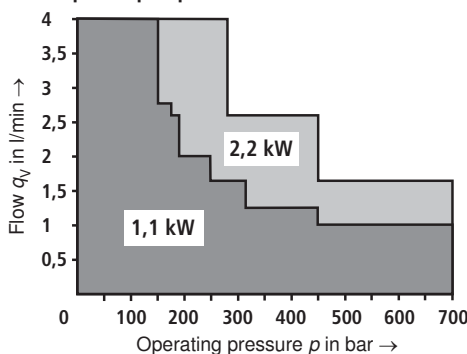

External gear pump

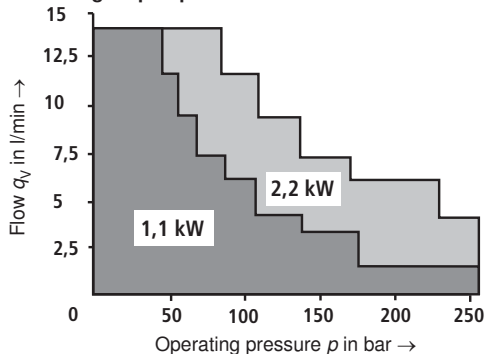

⁵⁾ The data is valid at a frequency of 50 Hz

Electric motor

The clamping and drive module is designed for the mode of operation according to VDE 0530 (EN 60034) for short-time operation S2 and intermittent operation S3 in the area of the nominal power. The electric motor complies with insulation

class F and the complete clamping and drive module with protection class IP 54.

The electric motor's direction of rotation depends on the pump installed (in this connection see Technical data page 4).

Technical Data (For applications outside these parameters, please consult us!)

Voltage ¹⁾	<i>U</i>	V	230 / 400 ±6 % Δ/Y
Frequency	<i>f</i>	Hz	50 / 60
Mode of operation	S2 short-time operation, S3 intermittent operation		
Insulation class	F (winding)		
Protection class	IP 54		
Number of poles	2 / 4		

Frequency 50 Hz

Power kW	Speed min ⁻¹	Power factor cos φ	Nom. current at	
			Δ 230 V	Y 400 V
1.1 ²⁾	1380	0.80	4.70 A	2.70 A
1.1 ³⁾	2820	0.85	4.45 A	2.55 A
2.2 ²⁾	1400	0.82	9.20 A	5.30 A
2.2 ³⁾	2890	0.85	8.35 A	4.80 A

Frequency 60 Hz

Power kW	Speed min ⁻¹	Power factor cos φ	Nom. current at	
			Δ 230 V	Y 400 V
1.1 ²⁾	1670	0.84	4.45 A	2.55 A
1.1 ³⁾	3380	0.88	4.10 A	2.35 A
2.2 ²⁾	1690	0.83	8.70 A	5.00 A
2.2 ³⁾	3420	0.88	7.80 A	4.50 A

¹⁾ Other voltages on request

²⁾ Number of poles 4

³⁾ Number of poles 2

Electromagnetic compatibility of devices (EMVG)

According to the "Act on the electromagnetic compatibility of devices (§2, subsection 4)" of the EEC directive, the clamping and drive module is no device that is ready-for-use. In order to avoid electromagnetic interference that might occur, we

recommend using the interference suppression elements by the company Murr-Elektronik in 71570 Oppenweiler. e.g. type 23050, 3 x400 VAC, 50-60 Hz

Terminal assignment

Terminal assignment in the terminal box at the clamping and drive module

Factory side:

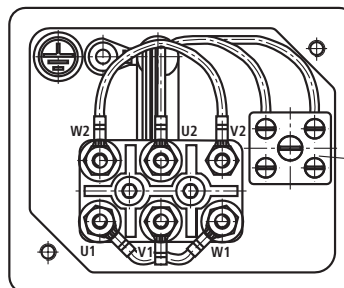

Temperature switch (optional)

Customer side: Δ triangle $U = 230$ V

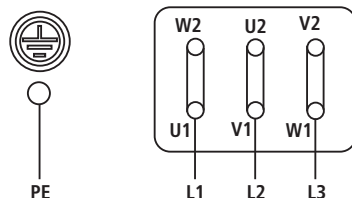

Customer side: Y star $U = 400$ V

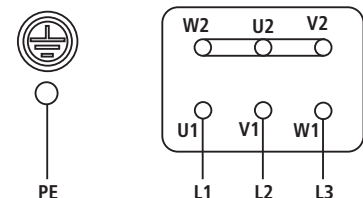

Dimensions (dimensions in mm)

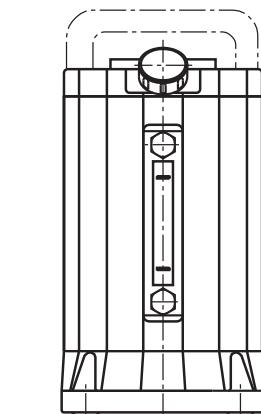
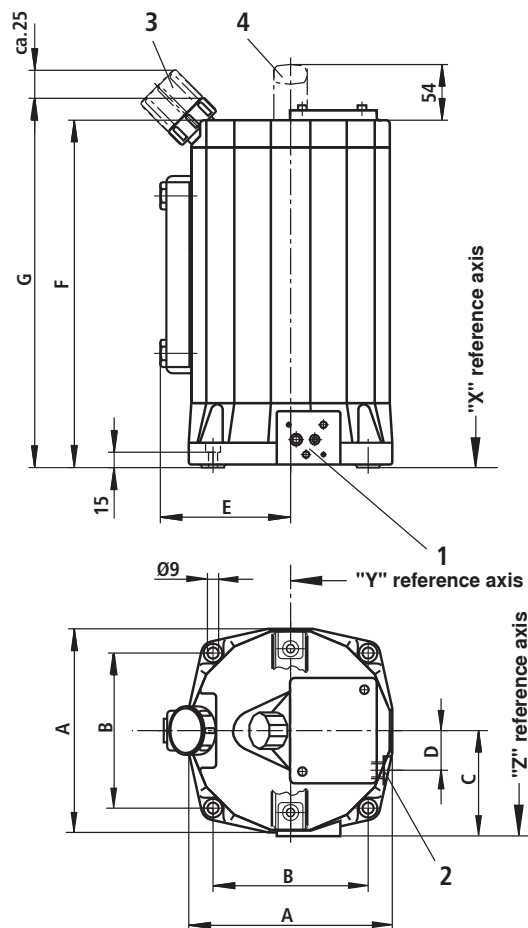

Tank size	A	B	C	D	E	F	G
3	164	125	85	40	105	280	295
4	164	125	85	40	105	390	405
5	190	156	98	50	118	320	335
7	190	156	98	50	118	450	465

X, Y and Z are reference axes for determining the installation dimensions when control blocks are mounted.

- 1 Control connection surface
- 2 Oil drain screw G 3/8
- 3 Ventilation filter
- 4 Carrying handle

Filling and removal quantity

	Tank Size	Size in liters	
		Radial piston pump	External gear pump
Filling quantity	3	2.4	
	4	4.5	4.1
	5	4.3	
	7	7.2	6.8
Removal quantity	3	1.0	
	4	3.0	2.6
	5	2.3	
	7	5.1	4.7
Removal quantity up to switching point of level switch	3	0.8	
	4	2.8	2.4
	5	2.0	
	7	4.8	4.4

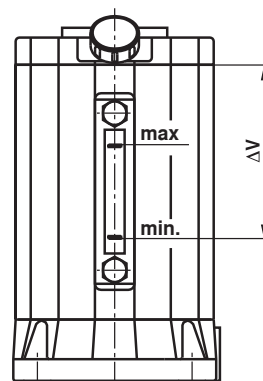

Not possible

Sound pressure level (measured at $v = 41 \text{ mm}^2/\text{s}$ and $\vartheta = 50 \text{ }^\circ\text{C}$)

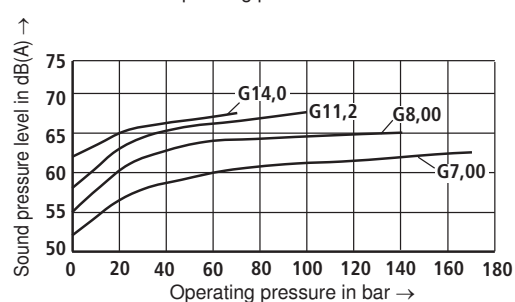
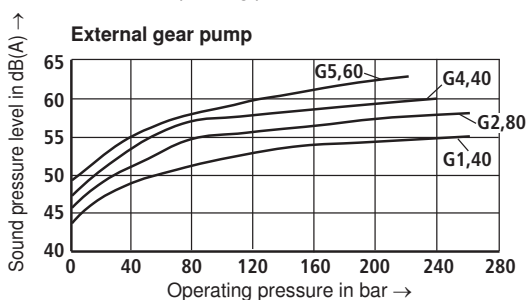
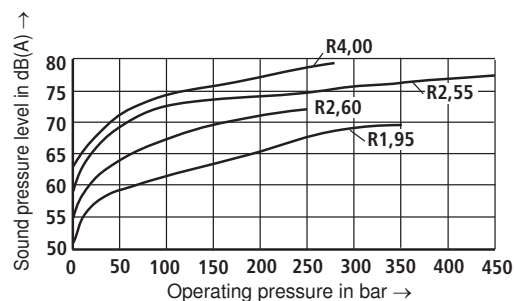
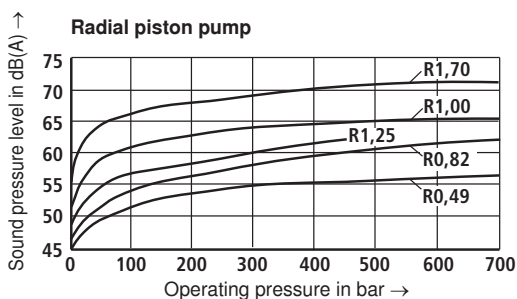

Level switch (option)

Description

The level switch provides for the electric monitoring of the hydraulic fluid level. If the minimum oil level is reached, the contact opens and thus outputs a signal to the control.

Electrical function

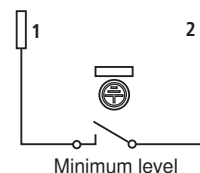
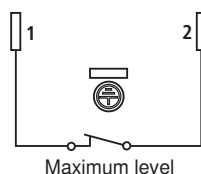

Technical data

Maximum voltage	V	50 AC / DC
Maximum current consumption	A	0.25
Maximum power consumption	W	3.0
Protection class		IP 65
Contact type		Normally closed contact

Temperature switch (option)

By means of the temperature switch, the clamping and drive module is protected from inadmissibly high hydraulic fluid temperatures. The temperature switch has a fixedly set switching point switching at a hydraulic fluid temperature of 80 °C.

The switch-back hysteresis is ca. 10 K.

Electrical function

 Temperature < 80 °C

 Temperature ≥ 80 °C

Technical data

Nominal current with 250 V AC 50/60 Hz (cos φ 0.95 / 0.60)	A	2.5 / 1.6
Nominal current with 50 V DC	A	0.25
Contact type		Normally closed contact
Tripping temperature	°C	80 ±3 K

Ventilation filter (option)

When the clamping and drive module is used in a heavily contaminated environment, we recommend using a ventilation filter.

The ventilation filter has a filter rating of 10 µm.

Oil tray (option) (dimensions in mm)

Size 3 and size 4 Material no. **R901109231**

Size 5 and size 7 Material no. **R901109235**

Color: RAL 7035 "Light gray"

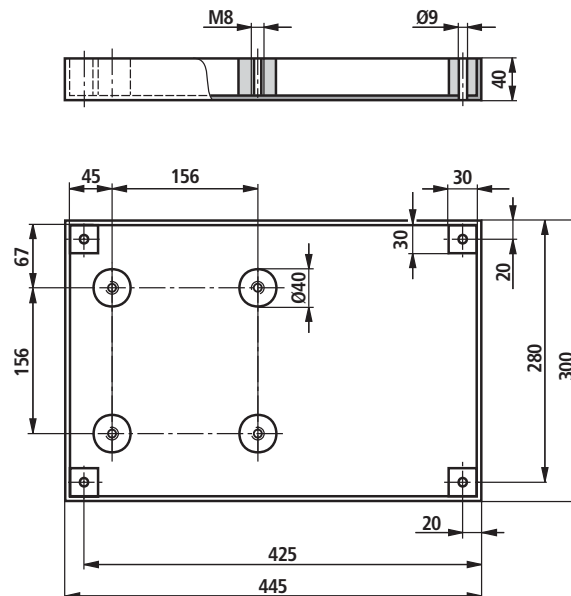

Commissioning notes

- Check whether the clamping and drive module has been connected to the machine to be operated in a professional form (hydraulically and electrically).
- For the electrical connections of the motor, the washers and connection bridges that are included in the scope of delivery must be used.
- The electric motor must be protected by means of equipment with an overload relay.
The later must be set to the nominal current that is specified on the name / rating plate.
- When installing the clamping and drive module at an external gear pump, you must imperatively observe the direction of rotation of the motor; see arrow indicating the direction of rotation.
(Practical check: Switch on the motor briefly and check whether the pump delivery fluid.)
(Optical check: Remove the ventilation filter at the tank cover, switch on the electric motor briefly and check the direction of rotation of the rotor shaft.)
- Only fill in the hydraulic fluid through a filter with the required minimum retention rate.
- The clamping and drive module must maximally be filled with hydraulic fluid until the dipstick is reached and/or to the lower edge of the cover.
- The clamping and drive module must in no case be operated without hydraulic fluid.
- Start up the clamping and drive module without load and allow it to run at zero pressure for some seconds in order to provide for sufficient lubrication.
- After bleeding the hydraulic control as well as the actuators by moving them back and forth several times or by opening available bleeding points, the hydraulic fluid in the clamping and drive module is to be refilled to the correct level.
- The clamping and drive module may only be operated within the permitted limits. It may moreover only be operated if it is in an unobjectionable condition.
- When carrying out any work at the clamping and drive module, the system must be depressurized and de-energized.
- Unauthorized conversions or modifications, which affect safety and function are not permitted.
- Existing protective devices must not be removed.
- The generally valid safety and accident prevention regulations must be observed and complied with.

Attention!

The clamping and drive module may heat up during operation => **risk of injury!**

The clamping and drive module may only be set, maintained and serviced by authorized, trained and instructed personnel.

In repairs, only original spare parts may be used!

Notes

© This document, as well as the data, specifications and other information set forth in it, are the exclusive property of Bosch Rexroth AG. It may not be reproduced or given to third parties without its consent. The data specified above only serve to describe the product. No statements concerning a certain condition or suitability for a certain application can be derived from our information. The information given does not release the user from the obligation of own judgment and verification. It must be remembered that our products are subject to a natural process of wear and aging.