



ROEMHELD
HILMA ■ STARK

Issue 5-16 E

M 4.401

Lifting module Strong

Max. lifting force 6,000 N, stroke from 200 to 400 mm,
manual-hydraulic and electro-mechanical version



Advantages

- Lifting force up to 6,000 N
- High load by steel guiding profile with high section modulus
- Rigid guiding system without clearance
- Sturdy and tough
- Compact design
- Ergonomic design
- Safe and precise handling

Application

Lifting modules for high demands in the industrial assembly.

Principal use

- Industrial production plants
- Automotive industry
- Assembly of car seats
- Drive technology, axes, cardan shafts
- Compressors, hydraulic elements, pumps
- Turbines, motors, gearbox construction
- Applications with frequent load changes

Fixing and installation

For fixing of *modulog* modules or other components of the user at the top plate the lifting module has an interface 140 x 140.

For fixing of *modulog* modules at the bottom plate the lifting module has an interface 200 x 200. This plate can also be used to fix the lifting module on a flat level floor. For fixing 4 screws M10 of property class 10.9 as well as heavy-duty plugs are to be used.

For increased stability also a base plate, which can be delivered as accessory, can be fixed at the bottom plate.

Description

The lifting module Strong has a high-tensile cylinder tube profile with chromium-plated surfaces. The high precision of the tube profile enables a guiding system without clearance and perfect smooth running.

The guiding profile is protected against rotary motion by a key connection with minimum clearance.

The guiding system works without fat and oil lubrication. High-quality materials for plain bearings are used.

Characteristic are applications with indifferent, dynamically swelling rotating motions and shock motions.

Material

Guiding system, top and base plates are made of steel. Materials for plain bearings are made on the base of polymers.

modulog Lifting module

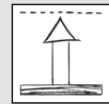

Part-no. 8919-06-X0-X

Technical characteristics

Max. lifting force: 6,000 N
Max. bending moment: 800 Nm
Stroke: 200 up to 400 mm

Operations

- Foot pedal
- Foot switch
- Hand panel



Combinable with the modules

- Rotating modules – horizontal axis as per data sheet M 1.101, and M 1.201



- Tilting modules KMB 100 as per data sheet M 2.101



- Rotating modules – vertical axis DMV 600 as per data sheet M 1.301



- Cart modules WMS as per data sheet M 5.101



- Floor modules FMS as per data sheet M 6.101



modulog interfaces

- Top plate: 140 x 140 – Ø 10.5 mm
- Bottom plate: 200 x 200 – Ø 10.5 mm

Accessories

- Foot switch and hand panel as per data sheet M 8.200
- Extension cable as per data sheet M 8.200
- Electrical supply units as per data sheet M 8.200
- Base and adaptor plates as per data sheet M 8.100 and M 8.110
- Table plates as per data sheet M 8.130

Manual-hydraulic version Operation with foot pedal



Description

The stroke movement is obtained by a hydraulic lifting jack with single-lever actuation, with oil being pumped by means of a piston pump into a plunger cylinder.

During retraction the oil returns due to the weight of the load from the cylinder back to the reservoir. A defined speed reduction is effected.

The manual-hydraulic version is particularly sturdy and durable. This variant meets high safety demands and withstands jerking and knocking loads in applications.

Operation

To lift the load, the foot pedal has to be depressed by approx. 40° several times. The pedal returns to its off-position by means of a return spring.

To lower the load, the foot pedal has to be moved upwards by approx. 10°.

Per 100 mm stroke 10 pump motions are required.

Descent speed approx. 25 mm/sec.

Code for part numbers

Part-no. 8919-06-X0-H

Stroke

2 = 200 mm
3 = 300 mm
4 = 400 mm

Technical characteristics

Stroke [mm]	A [mm]	A + stroke [mm]	Weight [kg]
200	520	720	50
300	620	920	55
400	720	1,120	60

Dimensions

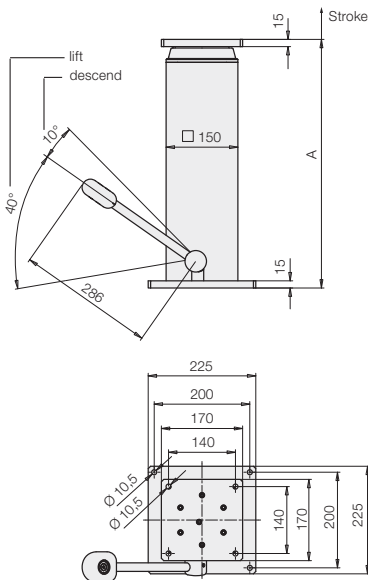

Maximum lifting force and maximum admissible torque load

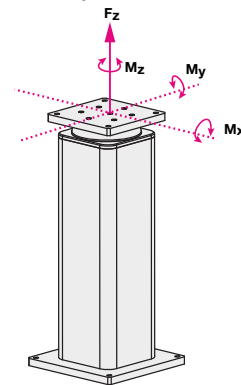

Accessories

Base plate for increased stability

Part-no. 6311-412

See data sheet M 8.100

Important notes!

To descend the lifting module a minimum load of approx. 100 N is required. The lifting module must only be pressure loaded. The centre of gravity should be within the traverse of the fixing screws. If the centre of gravity is outside, the dowelled joint with the floor has to be dimensioned correspondingly. In such cases it is recommended to use a larger base plate.

In case of eccentric load of more than 250 mm, the column cannot descend automatically because of too high friction forces.

The lifting module is designed for applications within closed rooms.

Maximum lifting force F_z : 6,000 N

Maximum torque load:

Total $M_{x/y}$: 800 Nm

M_z : 400 Nm

In the case of eccentric loads, it is recommended to compensate these by counterweights. In off-position the indicated maximum torques may occur.

The forces and torques have to be considered by the operator.

During the lifting motion only 50% of the maximum values are admitted.

Electro-mechanical version Operation with foot switch or hand panel



Description

The lifting motion is generated by an electric motor with a spindle lifting gear.
The electrically operated variant is particularly suitable for positioning and adjusting tasks of working tables as well as for material supply and transport.
They excel by a smooth running.

Code for part numbers

Part-no. 8919-06-X0-X

Stroke
2 = 200 mm
3 = 300 mm
4 = 400 mm

Control

E = individual operation
I = for memory control

Maximum lifting force F_z: 6,000 N

Admissible torque load and important notes

As per manual-hydraulic version (see page 2).

Dimensions

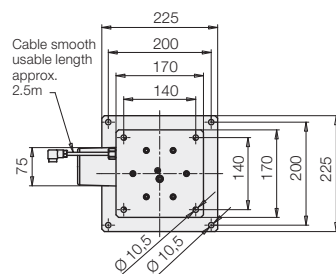
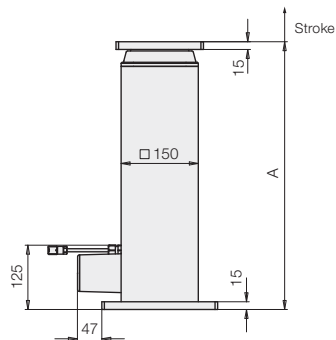

Accessories

Base plate for increased stability
Part-no. 6311-412
See data sheet M 8.100

Operation

Lifting and lowering is triggered by push-buttons with touch control contact. After release of the push-button, the motion will be immediately stopped.

Memory function

The hand panel for the memory function has four further push-buttons. To store a position, the lifting module is moved to a position, and then the push-button M is to be operated at the same time as position push-button 1, 2 or 3. Later the lifting unit can be moved again to the stored position by means of the position push-buttons 1, 2 or 3.
The stored positions are durably kept until they are overwritten by a new storage process.

Technical characteristics

Lifting speed (load-dependent)	7...5 mm/s
Electric connection	Plug
Duty cycle	15 % ED
Code class	IP 54
Control voltage (Power input)	24 VDC (200 W)
Current consumption	8 A

Delivery

The lifting modules are delivered ready for connection. Foot switch or hand panel as well as supply units and a mains cable have to be ordered separately as accessory.

Electrical accessories

See data sheet M 8.200

• Foot switch

with connecting cable 3.0 m
Part-no. 3823-038



• Hand panel

with connecting cable 1.6 m
Part-no. 3823-025



• Operating panel

with connecting cable 1.6 m for memory control
Part-no. 3823-109

• Supply unit

with control for one lifting module
Part-no. 3821-246



with memory control for one lifting module
Part-no. 3821-411 M

• Mains cable 230 VAC

with safety plug for supply units
Mains cable smooth, 3.0 m
Part-no. 3823-040