



ROEMHELD
HILMA ■ STARK

Issue 5-16 E

M 4.301

Lifting Module Shop-Floor

Max. lifting force 1,000 to 6,000 N, stroke from 200 to 600 mm,
manual-hydraulic and electro-mechanical version



Advantages

- Simple and intuitive operation
- Working in ergonomically optimum height
- Sturdy industrial design
- Increase of quality in manufacturing and assembly processes
- Short amortisation time
- Increase of assembly throughput and productivity
- High level of safety against static overloads

Application

Lifting module for workshop and assembly applications in the industry.

Principal use

- Industrial assembly working places
- Height adjustment of assembly working places in workshops
- Service
- Assembly fixtures
- Adjusting systems in supply processes of mid-sized objects
- Handling systems for product packing and transfer

Fixing and installation

For fixing of *modulog* modules or other components of the user at the top plate the lifting module has an interface 140 x 140.

For fixing of *modulog* modules at the bottom plate the lifting module has an interface 200 x 200. This plate can also be used to fix the lifting module on a flat level floor. For fixing 4 screws M10 of property class 10.9 as well as heavy-duty plugs are to be used.

For increased stability, a base plate (separately available as an accessory) can be fixed to the bottom plate.

Description

The lifting module Shop-Floor is particularly suitable for lifting and lowering assembly fixtures, working tables and demonstration objects in industrial applications as well as for medical treatment equipments in medical applications.

In general, lifting modules are used as a base unit of devices for controlled lifting and lowering of loads or for height adjustment only.

Material

Lifting profile: aluminium, naturally anodised
Top and bottom plate: aluminium, black anodised

modulog Lifting module

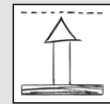

Part no. 8915-0X-X0-X

Technical data

Max. lifting force: 1,000 up to 6,000 N
Max. bending moment: 500 Nm
Stroke: 200 to 600 mm

Operation

- Foot pedal
- Foot switch
- Hand panel



Combinable with the modules

- Rotating module – horizontal axis
DMH 200
as per data sheet
M 1.101 / M 1.201



- Tilting modules KMB 100
as per data sheet
M 2.101 / M 2.201



- Rotating module – vertical axis
DMV 600
as per data sheet
M 1.301



- Cart modules
WMS
as per data sheet M 5.101



- Floor modules
FMS as per data sheet M 6.101
FMD as per data sheet M 6.201



modulog interfaces

- Top plate: 140 x 140 – Ø 10.5 mm
- Bottom plate: 200 x 200 – Ø 10.5 mm

Accessories

- Electrical control modules for 1, 2, 3 or 4 lifting modules as per data sheet M 8.200
- Control module with battery holder as per data sheet M 8.201
- Electrical operating elements, lines and connectors as per data sheet M 8.203
- Base and adaptor plates as per data sheet M 8.100 and M 8.110
- Table plates as per data sheet M 8.130 and M 8.131

Manual-hydraulic version Operation with foot pedal



Description

The stroke movement is obtained by a hydraulic lifting drive with single-lever actuation, with oil being pumped by means of a piston pump into a plunger cylinder. During retraction the oil returns due to the weight of the load from the cylinder back to the reservoir. A defined speed reduction is effected, independent of the load. The manual-hydraulic variant is particularly sturdy and durable. This variant meets high safety demands and withstands jerking and knocking loads in applications. According to the application 3 different force levels can be selected. The number of pump strokes depends on the force level.

Operation

To lift the load, the foot pedal has to be depressed by approx. 40° several times. The pedal returns to its off-position by means of a return spring. To lower the load, the foot pedal has to be moved upwards by approx. 10°.

Code for part numbers

Part no. **8915-0X-X0-H**

Maximum lifting force

2 = 2,000 N
4 = 4,000 N
6 = 6,000 N

Stroke

2 = 200 mm
3 = 300 mm
4 = 400 mm
5 = 500 mm
6 = 600 mm

Maximum lifting force and maximum admissible torque load

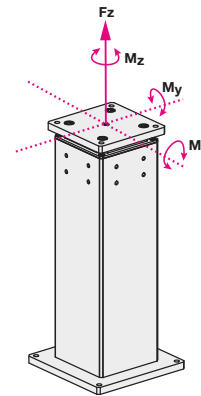

Dimensions

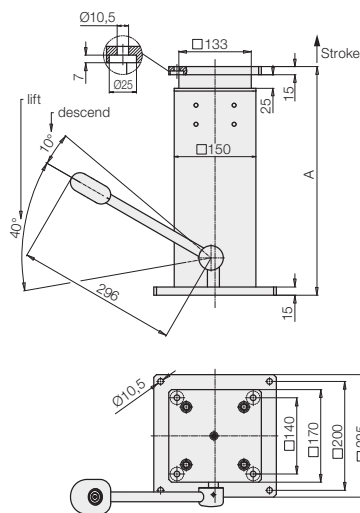

Stroke [mm]	A [mm]	A + stroke [mm]	Weight [kg]
200	420	620	15
300	520	820	20
400	620	1,020	25
500	720	1,220	30
600	820	1,420	35

Lifting force [N]	Pump strokes per 100 mm	Descent speed [mm/s]
2,000	5	approx. 45
4,000	7	approx. 22
6,000	9	approx. 22

Maximum lifting force Fz

Optionally 2,000 N, 4,000 N or 6,000 N (1,000 N only for the electro-mechanical version)

Maximum torque load:

Total M_{x/y}: 500 Nm
M_z: 300 Nm

Accessories

- Base plate for increased stability as per data sheet M 8.100

Important notes!

To descend the lifting module a minimum load of approx. 200 N is required.

The lifting module must only be pressure loaded. The centre of gravity should be within the traverse of the fixing screws. If the centre of gravity is outside, the dowelled joint with the floor has to be dimensioned correspondingly. In such cases it is recommended to use a larger base plate.

In case of eccentric load of more than 250 mm, the column cannot descend automatically because of too high friction forces.

The lifting module is designed for applications within closed rooms.

The hydro-manual lift drive can not be operated with synchronization control.

In the case of eccentric loads, it is recommended to compensate these by counterweights. In off-position the indicated maximum torques may occur.

The forces and torques have to be considered by the operator. **During the lifting motion only 50 % of the maximum values are admitted.**

Electro-mechanical version



Description

The lifting motion is generated by an electric motor with a spindle lifting gear. The electrically operated variant is particularly suitable for positioning and adjusting tasks of working tables as well as for material supply and transport. They excel by a smooth running.

Operation

Lifting and lowering is triggered by push-buttons with touch control contact. After release of the push-button, the motion will be immediately stopped.

Synchronization

Up to 4 lifting modules can be operated with synchronization control by a corresponding control module. For example complete lifting platforms can be designed.

For operation with synchronization control, only lifting modules with code letter G are suitable.

Control units with synchronization control for 2, 3, or 4 lifting modules are available.

Technical data

Electric connection	Plug
Duty cycle	15 % ED
Code class	IP 54
Control voltage	24 V DC

Variant E, I and B

Lifting force [N]	Lifting speed (load-dependent) [mm/s]	Current
		consumption (load dependent) [A]
1,000	32 ... 28	7
2,000	18 ... 16	6
4,000	10 ... 8	6
6,000	7 ... 5	7.5

Variant G

Lifting force [N]	Lifting speed (load-dependent) [mm/s]	Current
		consumption (load dependent) [A]
2,000	18 ... 16	6
4,000	8 ... 6	4.5
6,000	6 ... 4	5.5

Maximum lifting force, maximum admissible torque load and important notes

As per manual-hydraulic version (see page 2).

The maximum pull force of the electro-mechanical version is 80% of the push force!

Code for part numbers

Part no. 8915-0X-X0-X

Maximum lifting force

1 = 1,000 N (only for variant E + B)
2 = 2,000 N
4 = 4,000 N
6 = 6,000 N

Stroke

2 = 200 mm
3 = 300 mm
4 = 400 mm
5 = 500 mm
6 = 600 mm

Electronics

E = integrated stroke end disconnection (not suitable for synchronization control) with coiled connecting cable, 1.5 m
G = with incremental stroke measuring system (suitable for synchronization control) with smooth connecting cable, 2.5 m
I = with incremental stroke measuring system (suitable for memory function) with smooth connecting cable, 2.5 m
B = with incremental stroke measuring system (suitable for memory function and battery mode) with smooth connecting cable, 0.3 m

Delivery

The lifting modules are delivered ready for connection. The connecting cable from the lifting module to the control module is included in the delivery. Operating elements as well as control modules and mains cables can be ordered separately as an accessory.

Electrical accessories required for a functional system:

- Control modules as per data sheet M 8.200 or
- Control module with battery holder as per data sheet M 8.201
- Operating elements and mains cable as per data sheet M 8.203

Dimensions

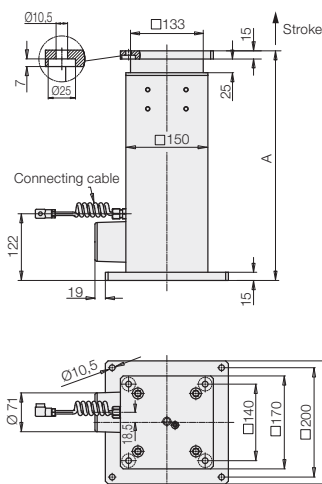

Accessories

- Base plate for increased stability as per data sheet M 8.100

Electro-mechanical version

Circuit diagram and connection plug-type connectors for lifting modules with stroke end disconnection (with last digit E)

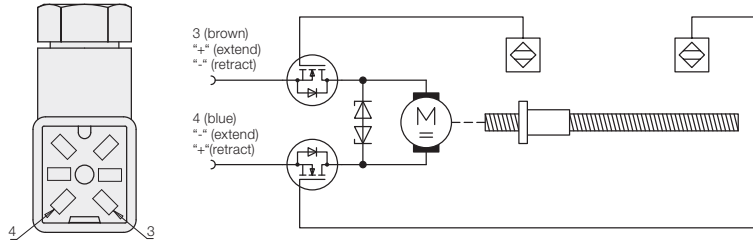

Circuit diagram and connection plug-type connectors for lifting modules with incremental stroke measuring system (with last digit I, B and G)

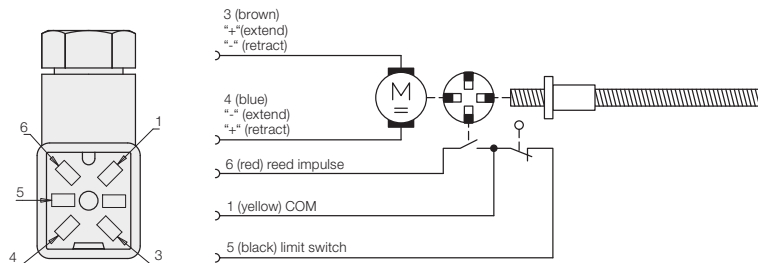

Resolution of the incremental stroke measuring system

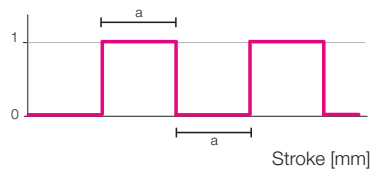

- 1 kN: a = 0.75 mm stroke
- 2 kN: a = 0.75 mm stroke
- 4 kN: a = 0.5 mm stroke
- 6 kN: a = 0.375 mm stroke