

Rexroth
Bosch Group

Axial Piston Variable Pump A10VSO

RE 92711/01.12 1/48
Replaces: 06.09
and RE 92707/11.10

Data sheet

Series 31
Sizes 18 to 140
Nominal pressure 280 bar
Maximum pressure 350 bar
Open circuit



Contents

Type code for standard program	2
Technical data	4
Technical data, standard unit	6
Technical data, high-speed version	7
DG – Two-point control, directly operated	10
DR – Pressure control	11
DRG – Pressure control, remotely operated	12
DFR, DFR1 – Pressure and flow control	13
DFLR – Pressure, flow and power control	14
ED – Electro-hydraulic pressure control	15
ER – Electro-hydraulic pressure control	16
Dimensions sizes 18 to 140	18
Dimensions through drive	36
Summary mounting options	41
Combination pumps A10VO + A10VO	42
Connector for solenoids	44
Installation instructions	46
General instructions	48

Features

- Variable pump in axial piston swashplate design for hydrostatic drives in an open circuit
- The flow is proportional to the drive speed and the displacement
- The flow can be steplessly varied by adjustment of the swashplate angle.
- 2 case drain ports
- Excellent suction characteristics
- Low noise level
- Long service life
- Axial and radial load capacity of drive shaft
- Favorable power/weight ratio
- Versatile controller range
- Short control time
- The through drive is suitable for adding gear pumps and axial piston pumps up to the same size, i.e., 100% through drive.

Type code for standard program

	A10VS	O			/	31		-	V					
01	02	03	04	05		06	07		08	09	10	11	12	13

Version		18	28	45	71	100	140	
01	Standard version (without symbol)	●	●	●	●	●	●	
	HFA, HFB, HFC hydraulic fluid (except for Skydrol)	-	●	●	●	●	●	E
	High-speed version	-	-	●	●	●	●	H

02	Axial piston unit	Swashplate design, variable, nominal pressure 280 bar, maximum pressure 350 bar	A10VS
----	-------------------	---	-------

03	Operation mode	Pump, open circuit	O
----	----------------	--------------------	---

04	Size (NG)	Geometric displacement, see table of values on pages 6 and 7	18	28	45	71	100	140
----	-----------	--	----	----	----	----	-----	-----

Control device		18	28	45	71	100	140	
05	Two-point control, directly operated	●	●	●	●	●	●	DG
	Pressure control	●	●	●	●	●	●	DR
	with flow control, hydraulic							
	X-T open	●	●	●	●	●	●	DFR
	X-T closed	●	●	●	●	●	●	DFR1
	with swivel angle control, electric	-	●	●	●	●	●	FE1 ¹⁾
	pressure and swivel-angle control, electric	●	●	●	●	●	●	DFE1 ¹⁾
	with pressure cut-off, remotely operated							
	hydraulic	●	●	●	●	●	●	DRG
	electrical negative characteristic	12V	●	●	●	●	●	ED71
	24V	●	●	●	●	●	●	ED72
	positive characteristic	12V	●	●	●	●	●	ER71 ²⁾
24V	●	●	●	●	●	●	ER72 ²⁾	
Pressure, flow and power control	-	●	●	●	●	●	DFLR	

06	Series	Series 3, Index 1	31
----	--------	-------------------	----

07	Direction of rotation	Viewed on drive shaft	clockwise	R
			counter clockwise	L

08	Seals	FKM (fluor-caoutchouc)	V
----	-------	------------------------	---

1) See RE 30030

2) The following must be taken into account during project planning:

Excessive current levels ($I > 1200$ mA with 12 V or $I > 600$ mA with 24 V) to the ER solenoid can result in undesired increase of pressure which can lead to pump or system damage:

- Use I_{max} current limiter solenoids.

- A sandwich plate pressure reducing valve can be used to protect the pump in the event of overflow.

An accessory kit with pressure reducing sandwich plate can be ordered from Rexroth under part number R902490825.

● = available ○ = on request - = not available

Type code for standard program

	A10VS	O			/	31		-	V					
01	02	03	04	05		06	07		08	09	10	11	12	13

		Drive shaft						
		18	28	45	71	100	140	
09	Splined shaft ANSI B92.1a	standard shaft	●	●	●	●	●	S
		similar to shaft "S" however for higher input torque	●	●	●	●	-	R
	Parallel keyed shaft DIN 6885	not for through drive	●	●	●	●	●	P

		Mounting flange						
		18	28	45	71	100	140	
10	ISO 3019-2	2-hole	●	●	●	●	●	A
		4-hole	-	-	-	-	-	●

		Service line port						
		18	28	45	71	100	140	
11	SAE flange ports on opposite side, metric fastening thread	●	●	●	-	●	●	12
		-	-	-	●	-	-	42

		Through drive						
		18	28	45	71	100	140	
	without through drive	●	●	●	●	●	●	N00
	Flange ISO 3019-1	coupling for splined shaft ¹⁾						
	Diameter	diameter						
	82-2 (A)	5/8 in	9T 16/32DP	●	●	●	●	K01
		3/4 in	11T 16/32DP	●	●	●	●	K52
	101-2 (B)	7/8 in	13T 16/32DP	-	●	●	●	K68
		1 in	15T 16/32DP	-	●	●	●	K04
	127-2 (C)	1 1/4 in	14T 12/24DP	-	-	●	●	K07
		1 1/2 in	17T 12/24DP	-	-	-	●	K24
12	152-4 (D)	1 3/4 in	13T 8/16DP	-	-	-	●	K17
	Ø 63, metric 4-hole	shaft key Ø 25						K57
	Flange ISO 3019-2							
	Diameter							
	80, 2-hole	3/4 in	11T 16/32DP	●	●	●	●	KB2
	100, 2-hole	7/8 in	13T 16/32DP	-	●	●	●	KB3
		1 in	15T 16/32DP	-	-	●	●	KB4
	125, 2-hole	1 1/4 in	14T 12/24DP	-	-	-	●	KB5
		1 1/2 in	17T 12/24DP	-	-	-	●	KB6
	180, 4-hole	1 3/4 in	13T 8/16DP	-	-	-	●	KB7

		Connectors for solenoids ²⁾						
		18	28	45	71	100	140	
13	HIRSCHMANN connector – without suppressor diode	●	●	●	●	●	●	H

¹⁾ Coupling for splined shaft as per ANSI B92.1a

²⁾ Connectors for other electric components can deviate.

● = available ○ = on request - = not available

Technical data

Hydraulic fluid

Before starting project planning, please refer to our data sheets RE 90220 (mineral oil) and RE 90221 (environmentally acceptable hydraulic fluids) for detailed information regarding the choice of hydraulic fluid and application conditions.

When using environmentally acceptable hydraulic fluids, the limitations regarding technical data and seals must be observed. Please contact us. When ordering, indicate the hydraulic fluid that is to be used.

Operating viscosity range

For optimum efficiency and service life we recommend that the operating viscosity (at operating temperature) be selected in the range

$$v_{opt} = \text{opt. operating viscosity } 16 \dots 36 \text{ mm}^2/\text{s}$$

referred to reservoir temperature (open circuit).

Limits of viscosity range

For critical operating conditions the following values apply:

$$n_{min} = 10 \text{ mm}^2/\text{s} \\ \text{short-term (t} \leq 1 \text{ min)} \\ \text{at max perm. case drain temperature of } 90 \text{ }^\circ\text{C.}$$

Please also ensure that the max. case drain temperature of 90 °C is not exceeded in localized areas (for instance, in the bearing area). The fluid temperature in the bearing area is approx. 5 K higher than the average case drain temperature.

$$n_{max} = 1000 \text{ mm}^2/\text{s} \\ \text{short-term (t} \leq 1 \text{ min)} \\ \text{on cold start} \\ (\text{p} \leq 30 \text{ bar, n} \leq 1000 \text{ rpm, t}_{min} \text{ -25 }^\circ\text{C})$$

Depending on the installation situation, special measures are necessary at temperatures between -40 °C and -25 °C. Please contact us.

For detailed information on operation with low temperatures see data sheet RE 90300-03-B.

Selection diagram

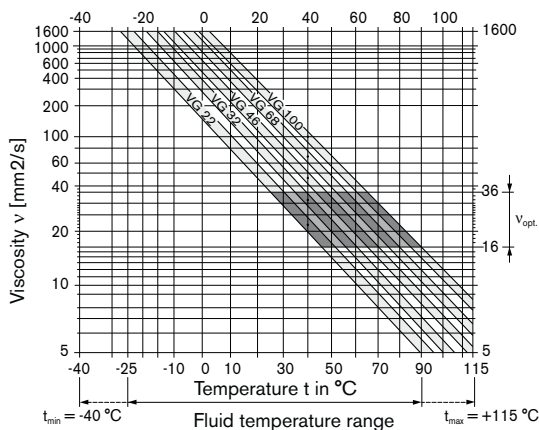

Notes on the choice of hydraulic fluid

In order to select the correct hydraulic fluid, it is necessary to know the operating temperature in the reservoir (open circuit) in relation to the ambient temperature.

The hydraulic fluid should be selected so that within the operating temperature range, the viscosity lies within the optimum range (v_{opt}), see shaded section of the selection diagram. We recommend to select the higher viscosity grade in each case.

Example: at an ambient temperature of X °C the operating temperature is 60 °C. In the optimum operating viscosity range (v_{opt} ; shaded area) this corresponds to viscosity grades VG 46 resp. VG 68; VG 68 should be selected.

Important:

The case drain temperature is influenced by pressure and input speed and is always higher than the reservoir temperature. However, at no point in the component may the temperature exceed 90 °C. The temperature difference specified on the left is to be taken into account when determining the viscosity in the bearing.

If the above conditions cannot be met, due to extreme operating parameters please contact us.

Filtration of the hydraulic fluid

The finer the filtration the better the cleanliness level of the hydraulic fluid and the longer the service life of the axial piston unit.

In order to guarantee the functional reliability of the axial piston unit it is necessary to carry out a gravimetric evaluation of the hydraulic fluid to determine the particle contamination and the cleanliness level according to ISO 4406. A cleanliness level of at least 20/18/15 must be maintained.

At very high hydraulic fluid temperatures (90 °C to maximum 115 °C), a cleanliness level of at least 19/17/14 according to ISO 4406 is necessary.

If the above cleanliness levels cannot be maintained, please contact us.

Technical data

Operating pressure range

Pressure at service line port B

Nominal pressure p_{nom} _____ 280 bar absolute

Maximum pressure p_{max} _____ 350 bar absolute

Single operating period _____ 2.5 ms

Total operating period _____ 300 h

Minimum pressure (high-pressure side) _____ 10 bar absolute¹⁾

Rate of pressure change $R_{A,max}$ _____ 16000 bar/s

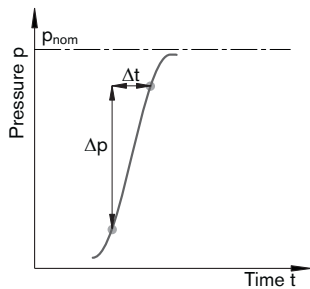

Pressure at suction port S (inlet)

Minimum pressure $p_{S,min}$ _____ 0.8 bar absolute

Maximum pressure $p_{S,max}$ _____ 10 bar¹⁾ absolute

Note

Please contact us for values for other hydraulic fluids.

Case drain pressure

Maximum permissible case drain pressure (at port L, L₁):

Maximum 0.5 bar higher than the inlet pressure at port S, however not higher than 2 bar absolute.

$p_{L,max,abs}$ _____ 2 bar absolute¹⁾

1) Other values on request

Definition

Nominal pressure p_{nom}

The nominal pressure corresponds to the maximum design pressure.

Maximum pressure p_{max}

The maximum pressure corresponds to the maximum operating pressure within the single operating period. The total of the single operating periods must not exceed the total operating period.

Minimum pressure (high-pressure side)

Minimum pressure in the high-pressure side (port B) that is required in order to prevent damage to the axial piston unit. The minimum pressure depends on the speed and displacement of the axial piston unit.

Rate of pressure change R_A

Maximum permissible pressure build-up and pressure reduction speed with a pressure change over the entire pressure range.

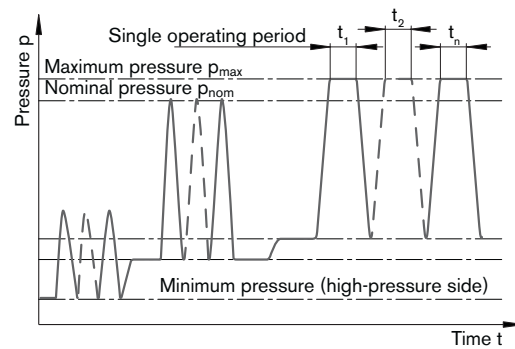

Total operating period = $t_1 + t_2 + \dots + t_n$

Technical data, standard unit

Table of values (theoretical values, without efficiencies and tolerances: values rounded)

Size	NG	18	28	45	71	100	140		
Geometrical displacement per revolution									
	$V_{g \max}$ cm ³	18	28	45	71	100	140		
Speed ¹⁾									
	maximum at $V_{g \max}$	n_{nom} rpm	3300	3000	2600	2200	2000	1800	
	maximum at $V_g < V_{g \max}$	$n_{\text{max perm}}$ rpm	3900	3600	3100	2600	2400	2100	
Flow									
	at n_{nom} and $V_{g \max}$	$q_{v \max}$ l/min	59	84	117	156	200	252	
	at $n_E = 1500$ rpm and $V_{g \max}$	$q_{vE \max}$ l/min	27	42	68	107	150	210	
Power at $\Delta p = 280$ bar									
	at n_{nom} , $V_{g \max}$	P_{max} kW	30	39	55	73	93	118	
	at $n_E = 1500$ rpm and $V_{g \max}$	$P_{E \max}$ kW	12.6	20	32	50	70	98	
Torque									
	at $V_{g \max}$ and	$\Delta p = 280$ bar	T_{max} Nm	80	125	200	316	445	623
		$\Delta p = 100$ bar	T Nm	30	45	72	113	159	223
Rotary stiffness, drive shaft									
	S	c Nm/rad	11087	22317	37500	71884	121142	169537	
	R	c Nm/rad	14850	26360	41025	76545	–	–	
	P	c Nm/rad	13158	25656	41232	80627	132335	188406	
Moment of inertial rotary group		J_{TW} kgm ²	0.00093	0.0017	0.0033	0.0083	0.0167	0.0242	
Angular acceleration, maximum ²⁾		α rad/s ²	6800	5500	4000	3300	2700	2700	
Filling capacity		V L	0.4	0.7	1.0	1.6	2.2	3.0	
Weight (without through drive) approx.		m kg	12	15	21	33	45	60	

1) The values are applicable:

- for an absolute pressure $p_{\text{abs}} = 1$ bar at suction port S
- within the optimum viscosity range from $v_{\text{opt}} = 16$ to 36 mm²/s
- for mineral-oil based hydraulic fluid.

2) The scope of application lies between the minimum necessary and the maximum permissible drive speeds.

Valid for external excitation (e.g. diesel engine 2- to 8-fold rotary frequency, cardan shaft 2-fold rotary frequency).

The limiting value is only valid for a single pump.

The loading capacity of the connecting parts must be taken into account.

Note

Exceeding the maximum or falling below the minimum permissible values can lead to a loss of function, a reduction in operational service life or total destruction of the axial piston unit. We recommend to check the loading through tests or calculation / simulation and comparison with the permissible values.

Determination of size

Flow	$q_v = \frac{V_g \cdot n \cdot \eta_v}{1000}$	[l/min]	V_g = Displacement per revolution in cm ³
			Δp = Differential pressure in bar
Torque	$T = \frac{V_g \cdot \Delta p}{20 \cdot \rho \cdot h_{mh}}$	[Nm]	n = Speed in rpm
			η_v = Volumetric efficiency
Power	$P = \frac{2\pi \cdot T \cdot n}{60000} = \frac{q_v \cdot \Delta p}{600 \cdot \eta_t}$	[kW]	η_{mh} = Mechanical-hydraulic efficiency
			η_t = Total efficiency ($\eta_t = \eta_v \cdot \eta_{mh}$)

Technical data, high-speed version

Table of values (theoretical values, without efficiencies and tolerances: values rounded)

Size	NG		45	71	100	140		
Geometrical displacement per revolution								
	$V_{g \max}$	cm ³	45	71	100	140		
Speed ¹⁾								
	maximum at $V_{g \max}$	n_{nom}	rpm	3000	2550	2300	2050	
	maximum at $V_g < V_{g \max}$	$n_{\text{max perm}}$	rpm	3300	2800	2500	2200	
Flow								
	at n_{nom} and $V_{g \max}$	$q_{v \max}$	l/min	135	178	230	287	
Power at $\Delta p = 280$ bar								
	at n_{nom} , $V_{g \max}$	P_{\max}	kW	63	83	107	134	
Torque								
	at $V_{g \max}$ and	$\Delta p = 280$ bar	T_{\max}	Nm	200	316	445	623
		$\Delta p = 100$ bar	T	Nm	72	113	159	223
Rotary stiffness, drive shaft								
	S	c	Nm/rad	37500	71884	121142	169537	
	R	c	Nm/rad	41025	76545	–	–	
	P	c	Nm/rad	41232	80627	132335	188406	
Moment of inertial rotary group								
	J_{TW}	kgm ²	0.0033	0.0083	0.0167	0.0242		
Angular acceleration, maximum ²⁾								
	α	rad/s ²	4000	3300	2700	2700		
Filling capacity								
	V	L	1.0	1.6	2.2	3.0		
Weight (without through drive) approx.								
	m	kg	21	33	45	60		

1) The values are applicable:

- for an absolute pressure $p_{\text{abs}} = 1$ bar at suction port S
- within the optimum viscosity range from $v_{\text{opt}} = 16$ to 36 mm²/s
- for mineral-oil based hydraulic fluid.

2) The scope of application lies between the minimum necessary and the maximum permissible drive speeds.

Valid for external excitation (e.g. diesel engine 2- to 8-fold rotary frequency, cardan shaft 2-fold rotary frequency).

The limiting value is only valid for a single pump.

The loading capacity of the connecting parts must be taken into account.

Note

Exceeding the maximum or falling below the minimum permissible values can lead to a loss of function, a reduction in operational service life or total destruction of the axial piston unit. We recommend to check the loading through tests or calculation / simulation and comparison with the permissible values.

Sizes 45, 71, 100 and 140 are optionally available in high-speed version.

External dimensions are not affected by this option.

Technical data

Permissible radial and axial loading on the drive shaft

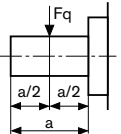
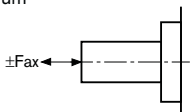
Size	NG	18	28	45	71	100	140
Radial force maximum at a/2	 $F_{q \max}$ N	350	1200	1500	1900	2300	2800
Axial force maximum	 $\pm F_{ax \max}$ N	700	1000	1500	2400	4000	4800

Permissible input and through-drive torques

Size	NG	18	28	45	71	100	140
Torque at $V_{g \max}$ and $\Delta p = 280 \text{ bar}^1$	T_{\max} Nm	80	125	200	316	445	623
Input torque for drive shaft, maximum ²⁾							
S	$T_{E \max}$ Nm	124	198	319	626	1104	1620
	\emptyset in	3/4	7/8	1	1 1/4	1 1/2	1 3/4
R	$T_{E \max}$ Nm	160	250	400	644	–	–
	\emptyset in	3/4	7/8	1	1 1/4	–	–
P	$T_{E \max}$ Nm	88	137	200	439	857	1206
	\emptyset mm	18	22	25	32	40	45
Maximum through-drive torque for drive shaft							
S	$T_{D \max}$ Nm	108	160	319	492	778	1266
R	$T_{D \max}$ Nm	120	176	365	548	–	–
P	$T_{D \max}$ Nm	88	137	200	439	778	1206

1) Without considering efficiency

2) For drive shafts free of radial load

Distribution of torques

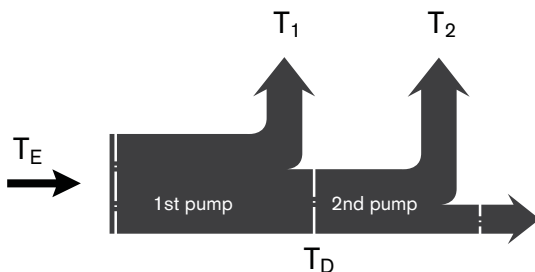

Technical data

Drive power and flow

Operating material:
Hydraulic fluid ISO VG 46 DIN 51519, $t = 50\text{ }^{\circ}\text{C}$

Size 18

--- n = 1500 rpm
— n = 3300 rpm

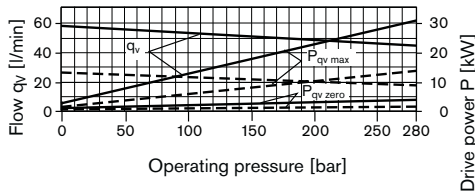

Size 28

--- n = 1500 rpm
— n = 3000 rpm

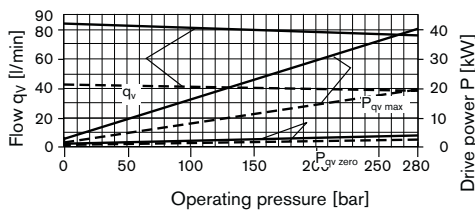

Size 45

--- n = 1500 rpm
— n = 2600 rpm

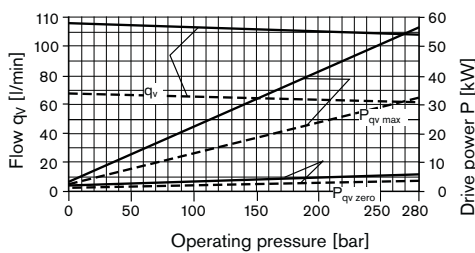

Size 71

--- n = 1500 rpm
— n = 2200 rpm

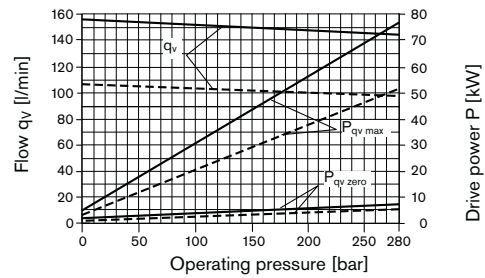

Size 100

--- n = 1500 rpm
— n = 2000 rpm

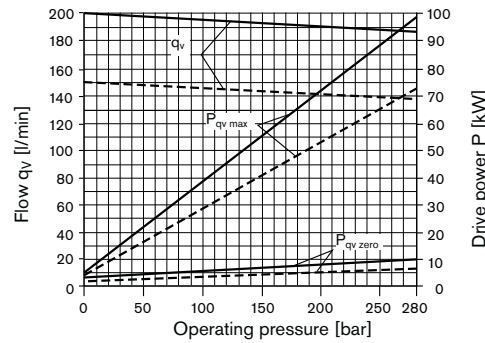

Size 140

--- n = 1500 rpm
— n = 1800 rpm

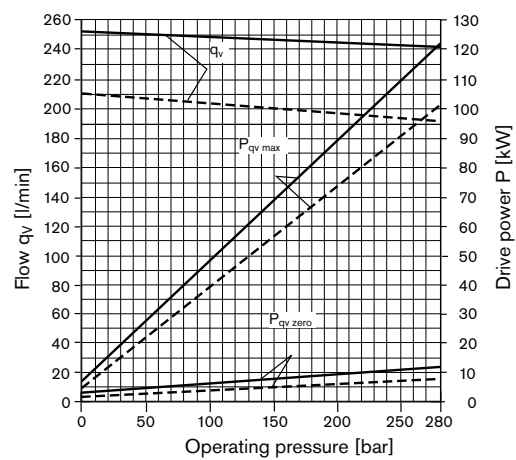

DG – Two-point control, directly operated

The variable pump can be set to a minimum swivel angle by connecting an external control pressure to port X.

This will supply control fluid directly to the stroke piston; a minimum control pressure of $p_{st} \geq 50$ bar is required.

The variable pump can only be switched between $V_{g\ max}$ or $V_{g\ min}$.

Please note, that the required control pressure at port X is directly dependent on the actual operating pressure p_B in port B. (See control pressure characteristic).

Control pressure p_{st} in X = 0 bar $\hat{=}$ $V_{g\ max}$

Control pressure p_{st} in X \geq 50 bar $\hat{=}$ $V_{g\ min}$

Control pressure characteristic

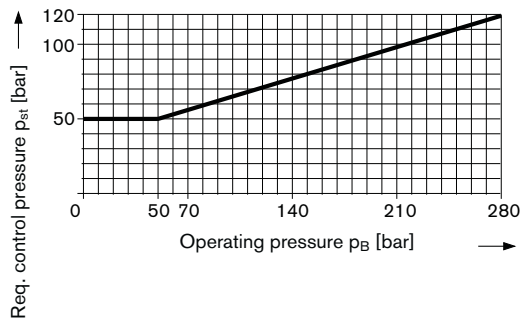

Circuit diagram

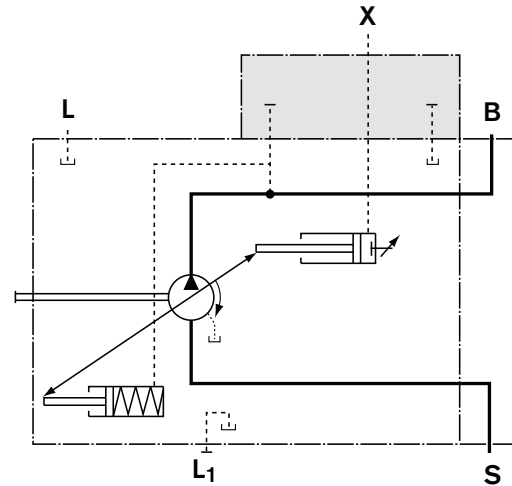

	Port for
B	Service line
S	Suction line
L, L ₁	Case drain (L ₁ plugged)
X	Pilot pressure

DR – Pressure control

The pressure control limits the maximum pressure at the pump output within the pump control range. The variable pump only supplies as much hydraulic fluid as is required by the consumers. If the operating pressure exceeds the pressure setpoint set at the integrated pressure valve, the pump will adjust towards a smaller displacement and the control deviation will be reduced. The pressure can be set steplessly at the control valve.

Static characteristic

(at $n_1 = 1500$ rpm; $t_{\text{fluid}} = 50$ °C)

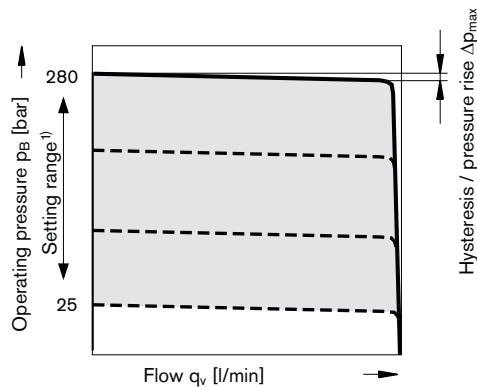

- 1) In order to prevent damage to the pump and the system, this setting range is the permissible setting range and must not be exceeded. The range of possible settings at the valve are greater.

Circuit diagram, sizes 18 to 100

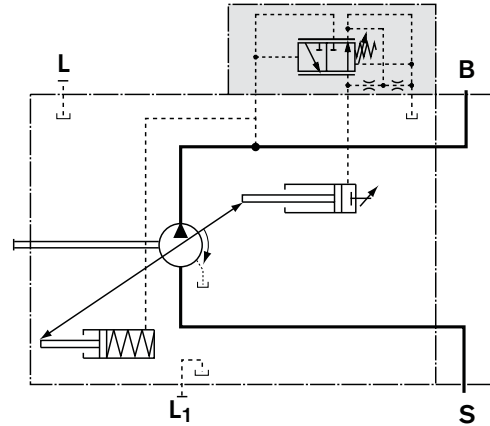

Circuit diagram, size 140

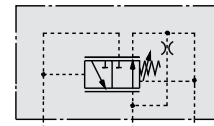

	Port for
B	Service line
S	Suction line
L, L ₁	Case drain (L ₁ plugged)

Control data

Hysteresis and repeatability Δp _____ maximum 3 bar

Pressure rise, maximum

NG	18	28	45	71	100	140
Δp bar	4	4	6	8	10	12

Control fluid consumption _____ maximum approx. 3 l/min

Flow losses at $q_{V\text{max}}$ see page 9.

DRG – Pressure control, remotely operated

The DR-control valve (see page 11) is overriding this DRG-remote setting of max. outlet pressure.

A pressure relief valve can be externally piped to port X for remote setting of pressure below the setting of the DR control valve spool. This relief valve is not included in the delivery contents of the DRG control.

The differential pressure at the DRG control valve is set as standard to 20 bar. This results in a pilot oil flow to the relief valve of approx. 1.5 l/min at port X. If another setting is required (range from 10-22 bar) please state in clear text.

As a separate pressure relief valve we can recommend:

DBDH 6 (hydraulic) to RE 25402 or

DBETR-SO 381 with orifice \varnothing 0.8 mm in P (electric) to RE 29166.

The max. length of piping should not exceed 2 m.

Static characteristic

(at $n_1 = 1500$ rpm; $t_{\text{fluid}} = 50$ °C)

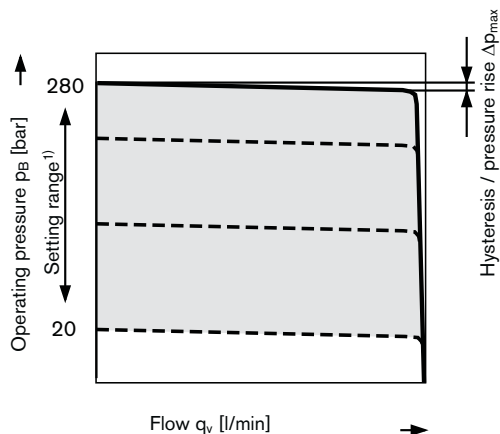

- 1) In order to prevent damage to the pump and the system, this setting range is the permissible setting range and must not be exceeded.
The range of possible settings at the valve are greater.

Circuit diagram, sizes 18 to 100

Not included in the delivery contents

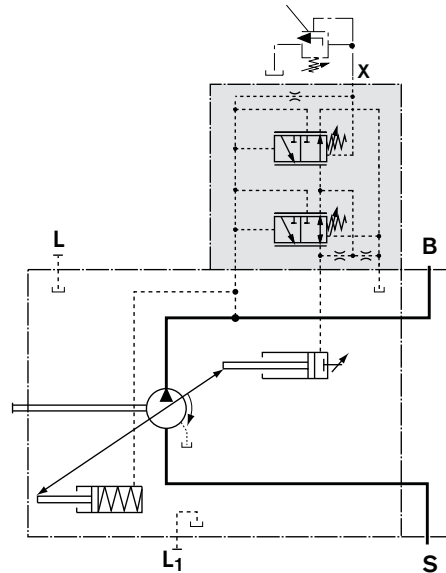

Circuit diagram, size 140

Not included in the delivery contents

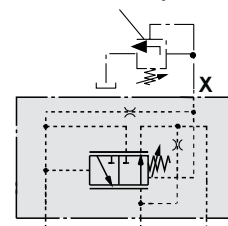

		Port for
B		Service line
S		Suction line
L, L₁		Case drain (L ₁ plugged)
X	NG 18 to 100 with adapter	Pilot pressure
X	NG 140 without adapter	Pilot pressure

Control data

Hysteresis and repeatability Δp _____ maximum 3 bar

Pressure rise, maximum

NG	18	28	45	71	100	140
Δp bar	4	4	6	8	10	12

Control fluid consumption _____ maximum approx. 4.5 l/min

Flow losses at $q_{v\text{max}}$ see page 9.

DFR/DFR1 – Pressure and flow control

In addition to the pressure control function (see page 11), the pump flow may be varied by means of a differential pressure over an adjustable orifice (e.g. directional valve) installed in the service line to the actuator. The pump flow is equal to the actual required flow by the actuator, regardless of changing pressure levels.

The pressure control overrides the flow control function.

Note

The DFR1 version has no connection between X and the reservoir. Unloading the LS-pilot line must be possible in the valve system.

Because of the flushing function sufficient unloading of the X-line must also be provided.

Static characteristic

Flow control at $n_1 = 1500 \text{ rpm}$; $t_{\text{fluid}} = 50 \text{ }^\circ\text{C}$

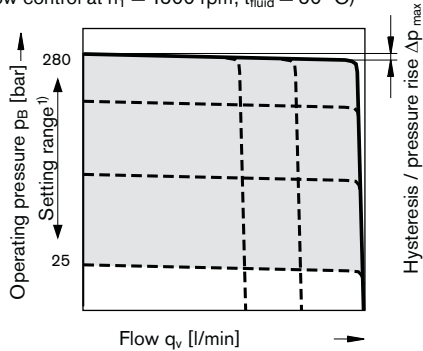

- In order to prevent damage to the pump and the system, this setting range is the permissible setting range and must not be exceeded. The range of possible settings at the valve are greater.

Static characteristic at variable speed

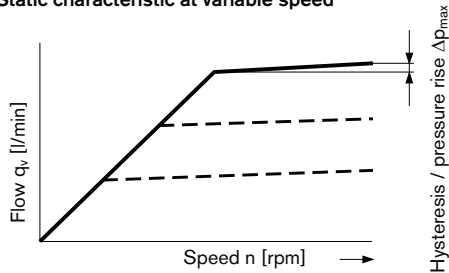

Differential pressure Δp

Standard setting: 14 to 22 bar.

If another setting is required, please state in clear text.

Relieving the load on port X to the reservoir results in a zero stroke ("standby") pressure which lies about 1 to 2 bar higher than the differential pressure Δp . System influences are not taken into account.

Circuit diagram, sizes 18 to 100

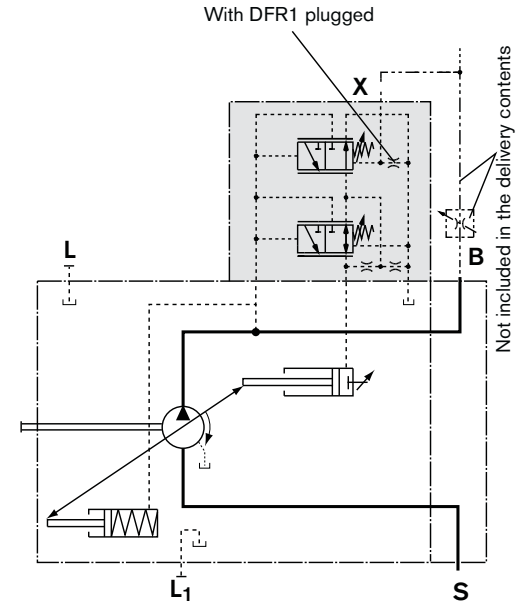

Circuit diagram, size 140

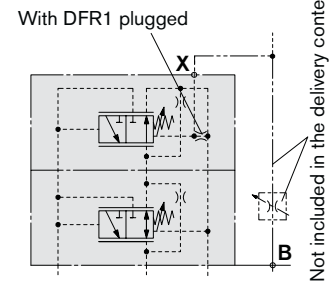

Port for	
B	Service line
S	Suction line
L, L ₁	Case drain (L ₁ plugged)
X	Pilot pressure

Control data

Data for pressure control DR, see page 11.

Maximum flow deviation measured at drive speed $n = 1500 \text{ rpm}$.

NG	18	28	45	71	100	140
$\Delta q_{v \text{ max}}$ l/min	0.9	1.0	1.8	2.8	4.0	6.0

Control fluid consumption DFR maximum approx. 3 to 4.5 l/min

Control fluid consumption DFR1 ____ maximum approx. 3 l/min

Volume flow loss at $q_{v \text{ max}}$, see page 9.

DFLR – Pressure, flow and power control

Execution of the pressure control DR(G), see page 11 (12).
Execution of the flow control like DFR, DFR1, see page 13.

In order to achieve a constant drive torque with varying operating pressures, the swivel angle and with it the output flow from the axial piston pump is varied so that the product of flow and pressure remains constant.

Flow control is possible below the power control curve.

The power characteristic is set in the factory; when ordering, please state in clear text, e.g. 20 kW at 1500 rpm.

Control data

For pressure control DR data, see page 11.
For flow control FR data, see page 13.

Static curves and torque characteristic

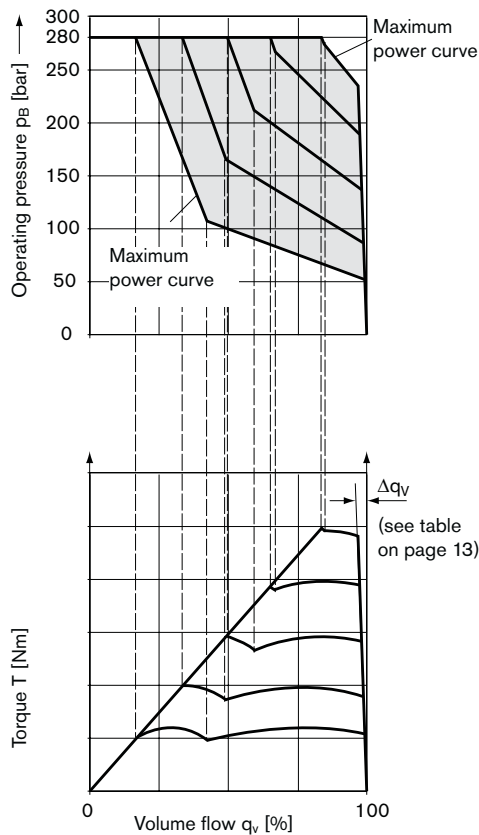

Control data

Beginning of control _____ 50 bar
Control fluid consumption _____ maximum approx. 5.5 l/min
Flow loss at q_v max, see page 9.

	Port for
B	Service line
S	Suction line
L, L ₁	Case drain (L ₁ plugged)
X	Pilot pressure

Circuit diagram, sizes 28 to 100

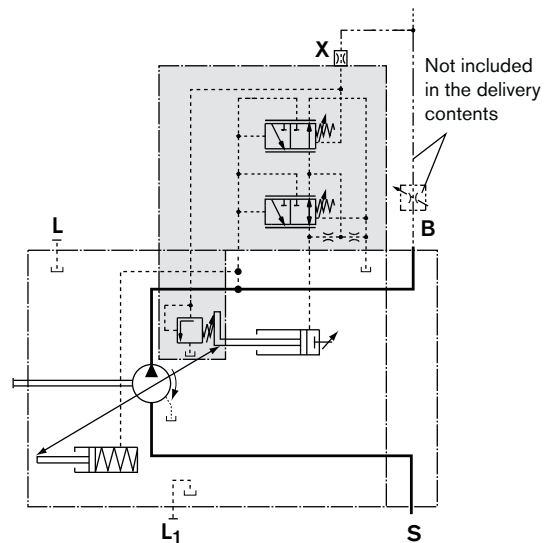

Circuit diagram, size 140

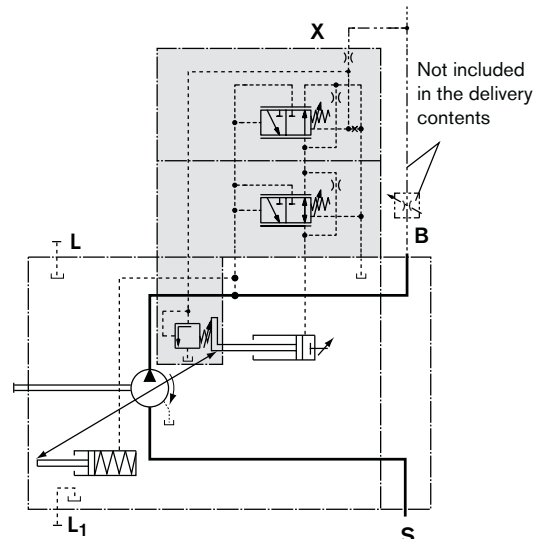

ED – Electro-hydraulic pressure control

The ED valve is set to a certain pressure by a specified, variable solenoid current.

If there is a change at the consumer (load pressure), the position of the control piston changes.

This causes an increase or decrease in the pump swivel angle (flow) in order to maintain the electrically set pressure level.

The pump thus only delivers as much hydraulic fluid as the consumers can take. The desired pressure level can be set steplessly by varying the solenoid current.

When the solenoid current signal drops towards a zero value, the maximum output pressure is limited to p_{max} by an adjustable hydraulic pressure cut-off (secure fail safe function in case of a loss of power e.g. for use as fan drives).

The response time characteristic of the ED-control was optimized for the use as a fan drive system.

When ordering, state the type of application in clear text.

Influence of pressure setting on standby level

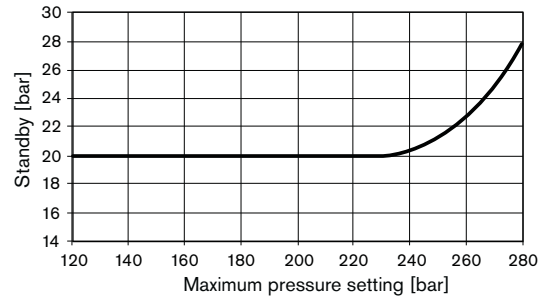

Circuit diagram ED..

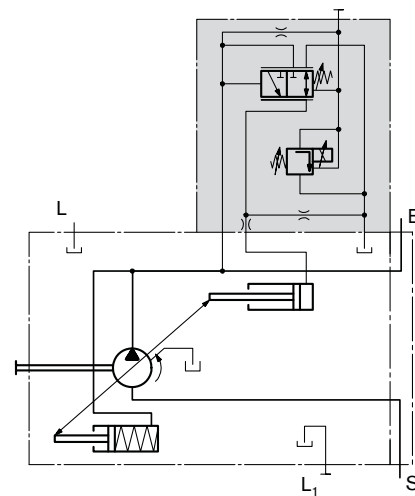

Static current-pressure characteristic ED

(measured at pump in zero stroke – negative characteristic)

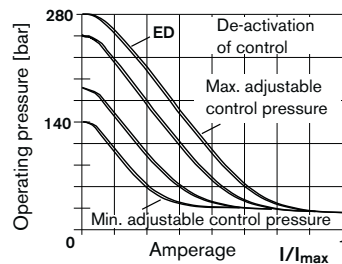

Hysteresis of the static current-pressure characteristic < 3 bar

Static flow-pressure characteristic

(at $n = 1500$ rpm; $t_{fluid} = 50$ °C)

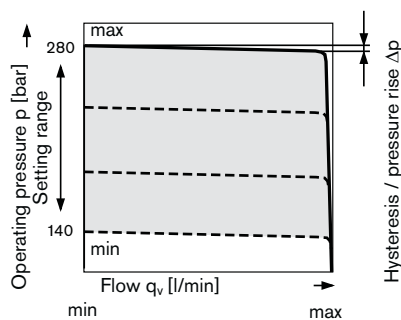

Control data

Stand-by standard setting 20 bar, other values on request.

Hysteresis and pressure increase $\Delta p < 4$ bar

Control fluid consumption 3 to 4.5 l/min.

Port for	
B	Service line
S	Suction line
L, L ₁	Case drain (L ₁ plugged)

Technical data, solenoid	ED71	ED72
Voltage	12 V (±20 %)	24 V (±20 %)
Control current		
Control begin at $q_{v\ min}$	100 mA	50 mA
End of control at $q_{v\ max}$	1200 mA	600 mA
Limiting current	1.54 A	0.77 A
Nominal resistance (at 20 °C)	5.5 Ω	22.7 Ω
Dither frequency	100 to 200 Hz	100 to 200 Hz
Actuated time	100 %	100 %

For type of protection, see plug design on page 43

For details on the control electronics, see page 16

Operating temperature range at valve -20 °C to +115 °C

ER – Electro-hydraulic pressure control

The ER valve is set to a specific pressure by a specified, variable solenoid current.

If there is a change at the consumer (load pressure), the position of the control piston changes.

This causes an increase or decrease in the pump swivel angle (flow) in order to maintain the electrically set pressure level.

The pump thus only delivers as much hydraulic fluid as the consumers can take. The desired pressure level can be set steplessly by varying the solenoid current.

If the solenoid current drops to zero, the pressure is limited to p_{min} (stand-by).

Observe the project planning note on page 2.

Static current-pressure characteristic ER

(measured at pump in zero stroke – positive characteristic)

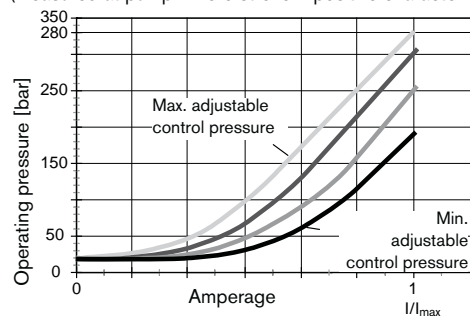

Hysteresis of the static current-pressure characteristic < 3 bar

Influence of pressure setting on stand-by ± 2 bar

Static flow-pressure characteristic

(at $n = 1500$ rpm; $t_{fluid} = 50$ °C)

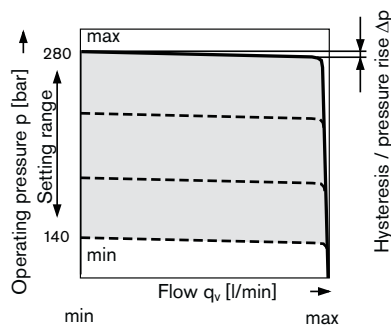

Control data

Standby standard setting 20 bar, other values on request.

Hysteresis and pressure increase _____ $\Delta p < 4$ bar

Control fluid consumption _____ 3 to 4.5 l/min.

Circuit diagram ER..

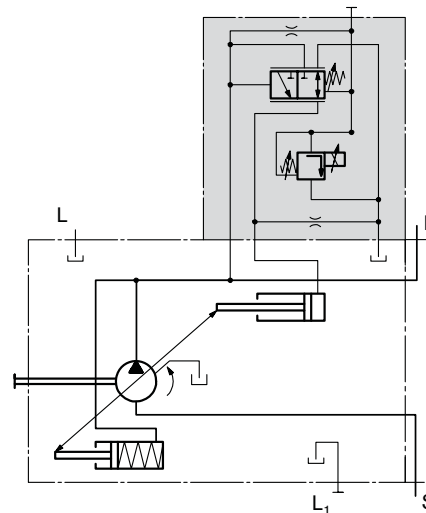

	Port for
B	Service line
S	Suction line
L, L1	Case drain (L1 plugged)

Technical data, solenoid	ED71	ED72
Voltage	12 V (± 20 %)	24 V (± 20 %)
Control current		
Control begin at $q_{v\ min}$	100 mA	50 mA
End of control at $q_{v\ max}$	1200 mA	600 mA
Limiting current	1.54 A	0.77 A
Nominal resistance (at 20 °C)	5.5 Ω	22.7 Ω
Dither frequency	100 to 200 Hz	100 to 200 Hz
Actuated time	100 %	100 %

For type of protection, see plug design on page 43

Operating temperature range at valve -20 °C to +115 °C

The following electric controllers and amplifiers are available for controlling the proportional solenoids:

Analog amplifier RA	RE 95230
Digital controller RC2-2/21 ¹⁾	RE 95201
Analog amplifier VT2000 ²⁾	RE 29904
Analog amplifier VT 11029/11030 ²⁾	RE 29741

1) Power outlets for 2 valves, can be actuated separately

2) Only 24V nominal voltage

Notes

Dimensions size 18

Before finalizing your design request a certified installation drawing. Dimensions in mm.

DFR, DFR1 – Pressure and flow control, hydraulic

Clockwise rotation

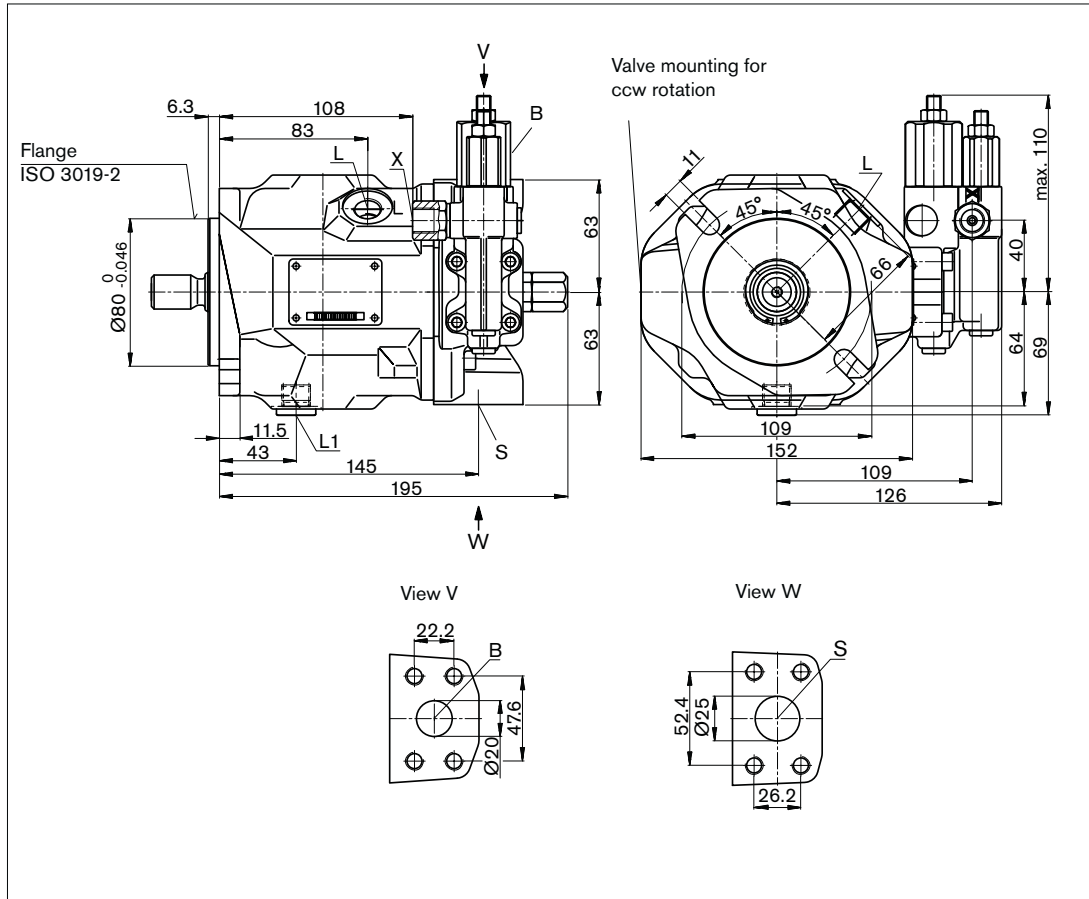

Ports

Designation	Port for	Standard	Size ¹⁾	Maximum pressure [bar] ²⁾	State
B	Service line, fastening thread	SAE J518 ³⁾ DIN 13	3/4 in M10 x 1.5; 17 deep	350	O
S	Suction line, fastening thread	SAE J518 ³⁾ DIN 13	1 in M10 x 1.5; 17 deep	10	O
L	Case drain fluid	DIN 3852 ⁴⁾	M16 x 1.5; 12 deep	2	O ⁵⁾
L ₁	Case drain fluid	DIN 3852 ⁴⁾	M16 x 1.5; 12 deep	2	X ⁵⁾
X	Pilot pressure	DIN 3852 ⁴⁾	M14 x 1.5; 12 deep	350	O
X	Pilot pressure with DG-control	DIN ISO 228 ⁴⁾	G 1/4 in	350	O

- 1) For the maximum tightening torques the general instructions on page 48 must be observed
 - 2) Depending on the application, short-term pressure spikes can occur. Keep this in mind when selecting measuring equipment and fittings. Pressure values in bar absolute.
 - 3) Only dimensions according to SAE J518, metric fastening thread deviating from the standard
 - 4) The spot face can be deeper than as specified in the standard
 - 5) Depending on the installation position, L or L₁ must be connected (see also installation instructions on pages 44, 45)
- O = Must be connected (plugged on delivery)
X = Plugged (in normal operation)

Dimensions size 18

Before finalizing your design request a certified installation drawing. Dimensions in mm.

Drive shaft

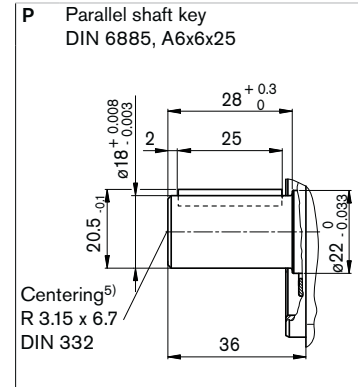
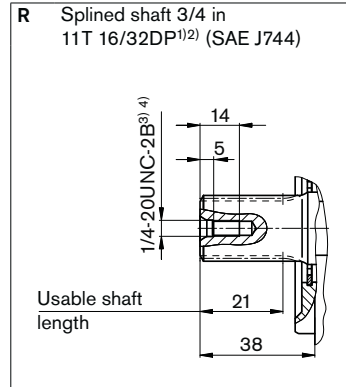
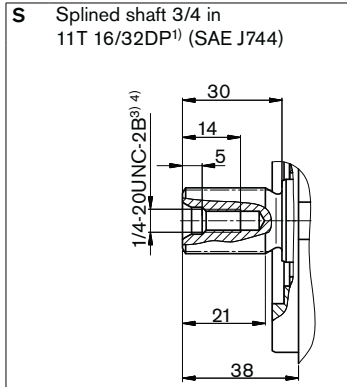

- 1) ANSI B92.1a, 30° pressure angle, flat root, side fit, tolerance class 5
- 2) Splines according to ANSI B92.1a, run out of spline is a deviation from standard
- 3) Thread according to ASME B1.1
- 4) For the maximum tightening torques the general instructions on page 48 must be observed
- 5) Coupling axially secured, e.g. with a clamp coupling or radially mounted clamping screw

Dimensions size 18

Before finalizing your design request a certified installation drawing. Dimensions in mm.

DG

Two-point control, directly operated

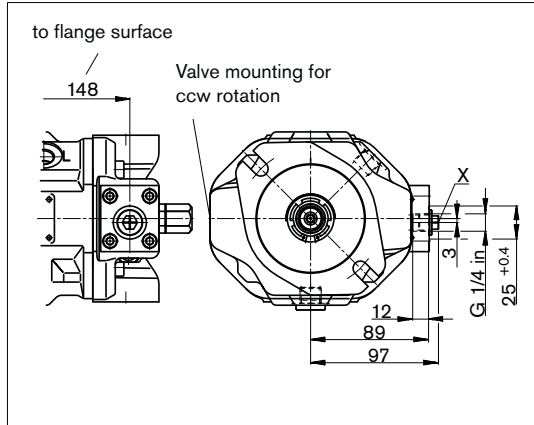

DR

Pressure control

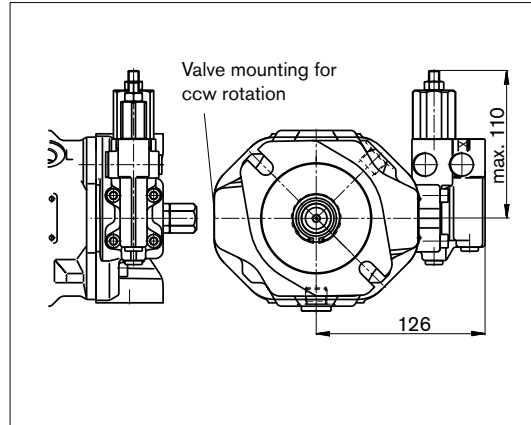

DRG

Pressure control, remotely operated

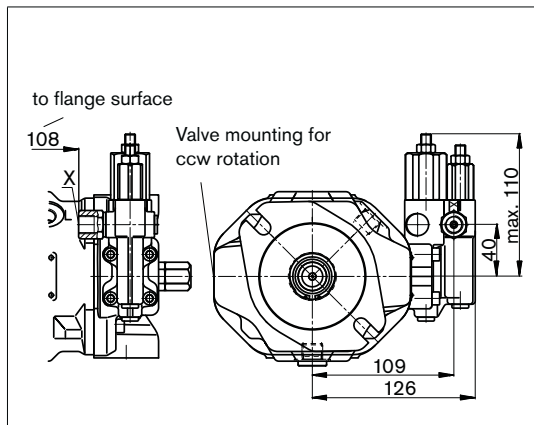

ED7., ER7.

Electro-hydraulic pressure control

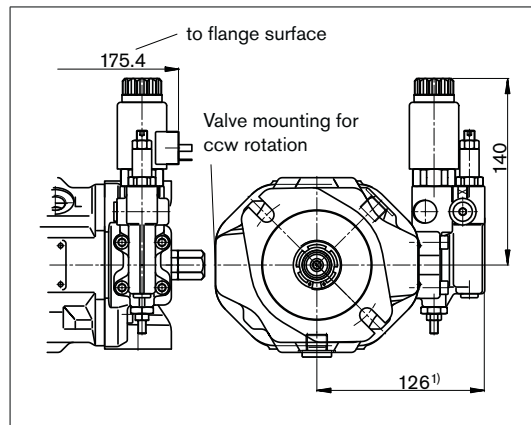

1) ER7.: 161 mm if using a sandwich plate pressure reducing valve.

Dimensions size 28

Before finalizing your design request a certified installation drawing. Dimensions in mm.

DFR/DFR1 – Pressure and flow control, hydraulic

Clockwise rotation

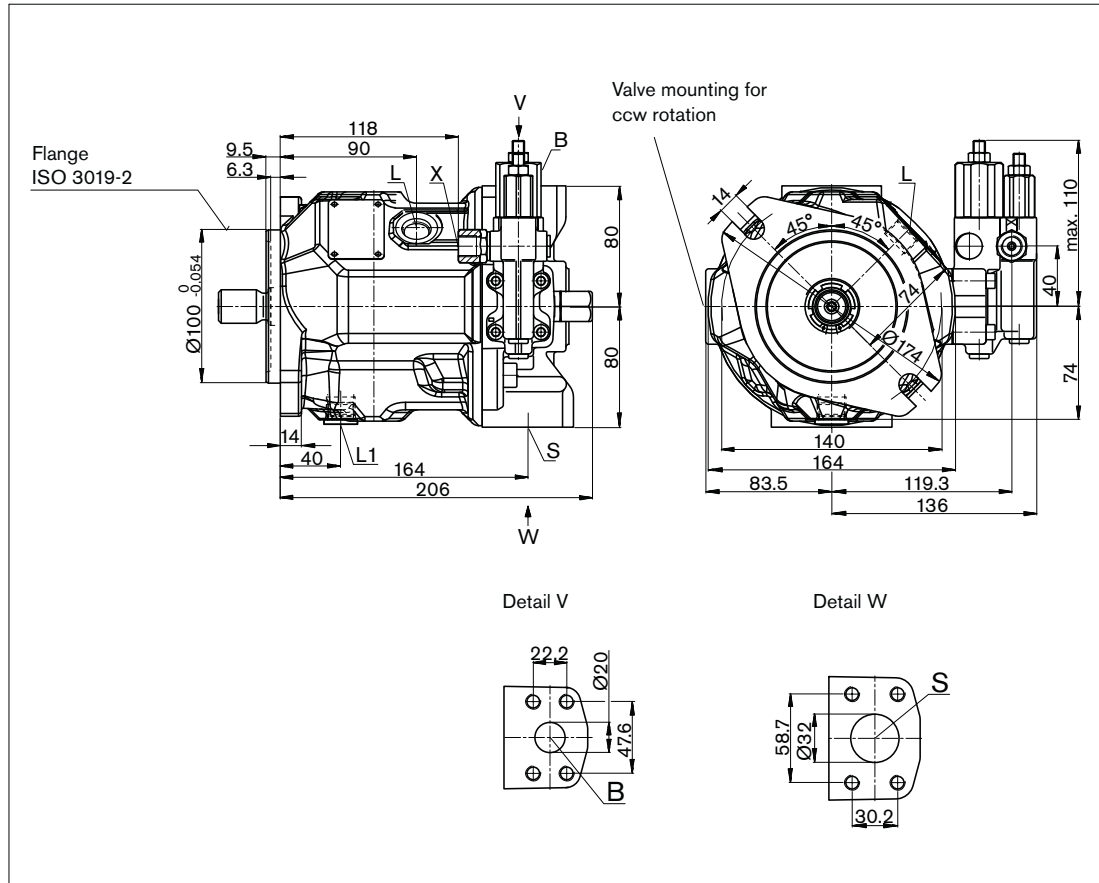

Ports

Designation	Port for	Standard	Size ¹⁾	Maximum pressure [bar] ²⁾	State
B	Service line, fastening thread	SAE J518 ³⁾ DIN 13	3/4 in M10 x 1.5; 17 deep	350	O
S	Suction line, fastening thread	SAE J518 ³⁾ DIN 13	1 1/4 in M10 x 1.5; 17 deep	10	O
L	Case drain fluid	DIN 3852 ⁴⁾	M18 x 1.5; 12 deep	2	O ⁵⁾
L ₁	Case drain fluid	DIN 3852 ⁴⁾	M18 x 1.5; 12 deep	2	X ⁵⁾
X	Pilot pressure	DIN 3852 ⁴⁾	M14 x 1.5; 12 deep	350	O
X	Pilot pressure with DG-control	DIN ISO 228 ⁴⁾	G 1/4in; 12 deep	350	O

- 1) For the maximum tightening torques the general instructions on page 48 must be observed.
 - 2) Depending on the application, short-term pressure spikes can occur. Consider this when selecting measuring equipment and fittings. Pressure values in bar absolute.
 - 3) Only dimensions according to SAE J518, metric fastening thread deviating from the standard.
 - 4) The spot face can be deeper than as specified in the standard.
 - 5) Depending on the installation position, L or L₁ must be connected (see also installation instructions on pages 44, 45)
- O = Must be connected (plugged on delivery)
X = Plugged (in normal operation)

Dimensions size 28

Before finalizing your design request a certified installation drawing. Dimensions in mm.

Drive shaft

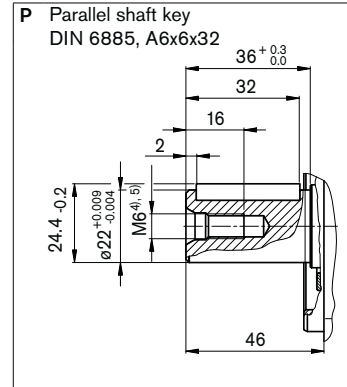
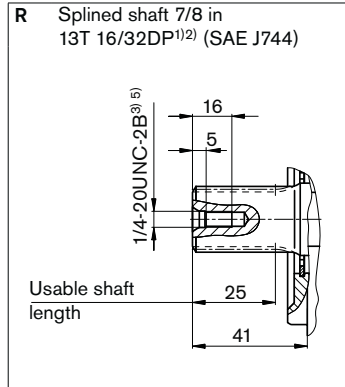
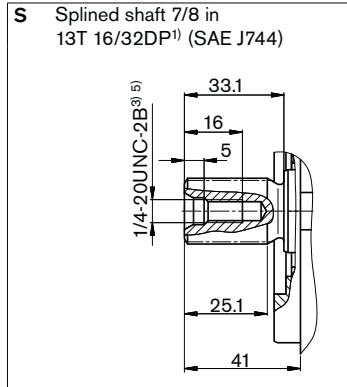

- 1) ANSI B92.1 a, 30° pressure angle, flat root, side fit, tolerance class 5
- 2) Spline according to ANSI B92.1a, run out of spline is a deviation from standard.
- 3) Thread according to ASME B1.1
- 4) Thread according to DIN 13
- 5) For the maximum tightening torques the general instructions on page 48 must be observed.

Dimensions size 28

Before finalizing your design request a certified installation drawing. Dimensions in mm.

DG

Two-point control, directly operated

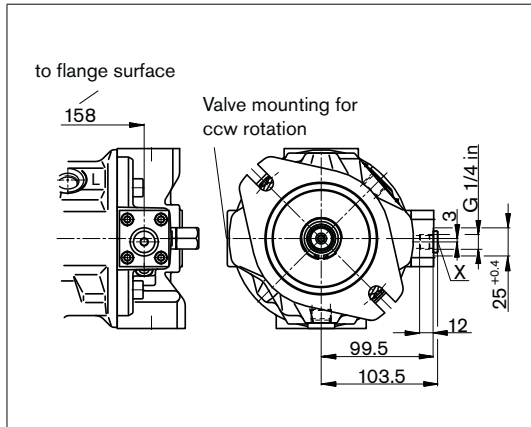

DFLR

Pressure, flow and power control

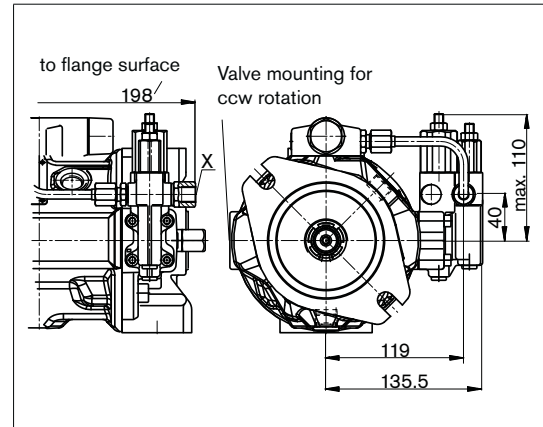

DR

Pressure control

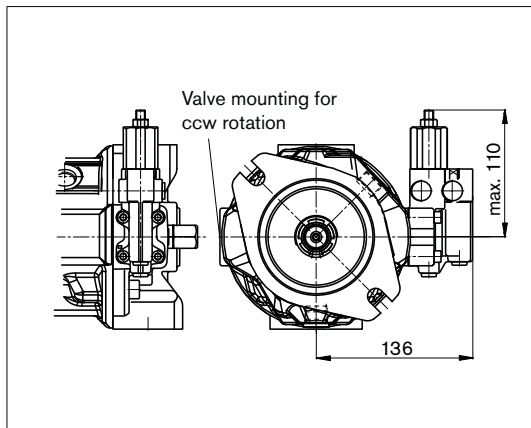

DRG

Pressure control, remotely operated

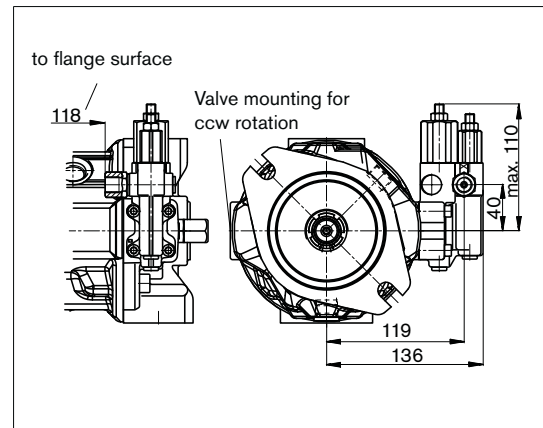

ED7. / ER7.

Electro-hydraulic pressure control

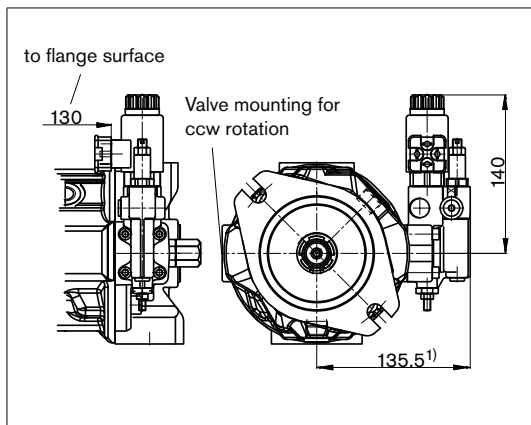

1) ER7.: 170.5 mm when using a sandwich plate pressure reducing valve.
For details of connection options and drive shafts, see also pages 21 and 22

Dimensions size 45

Before finalizing your design request a certified installation drawing. Dimensions in mm.

DFR/DFR1 – Pressure and flow control, hydraulic

Clockwise rotation

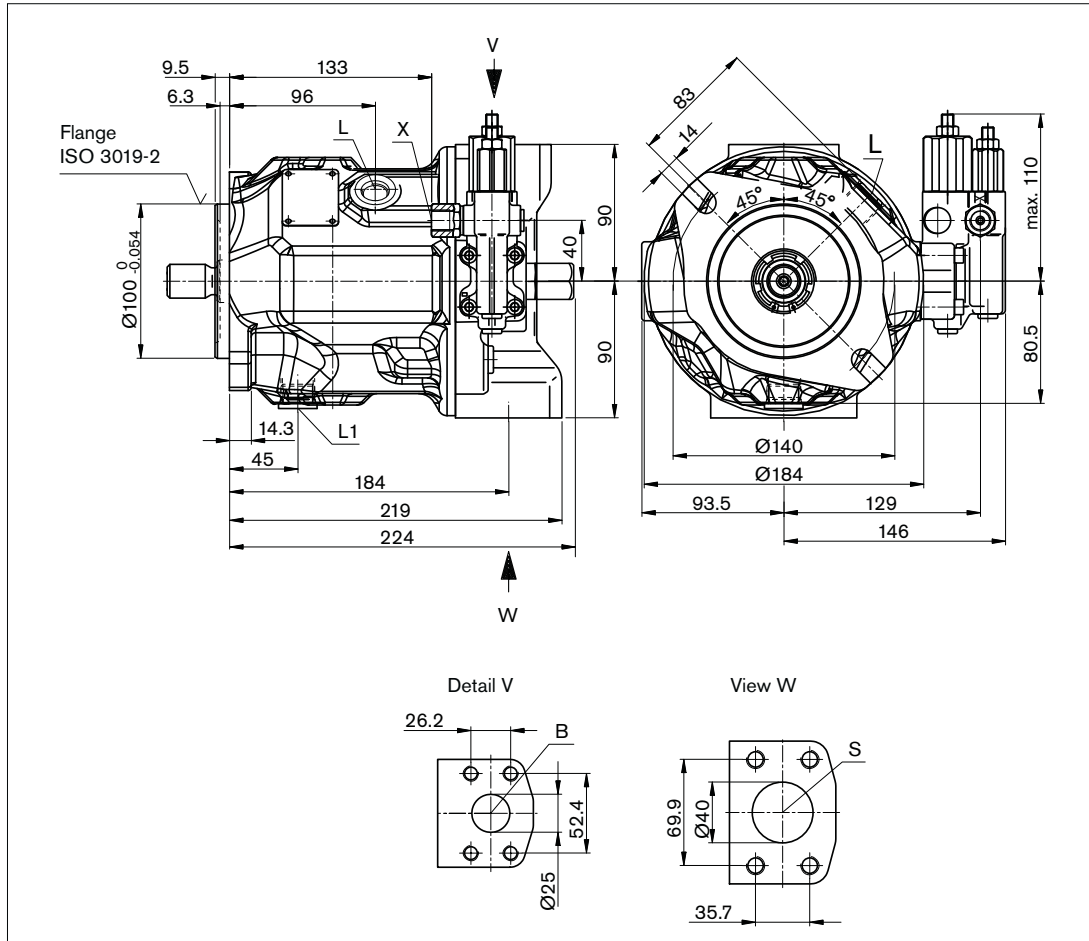

Ports

Designation	Port for	Standard	Size ¹⁾	Maximum pressure [bar] ²⁾	State
B	Service line, fastening thread	SAE J518 ³⁾ DIN 13	1 in M10 x 1.5; 17 deep	350	O
S	Suction line, fastening thread	SAE J518 ³⁾ DIN 13	1 1/2 in M12 x 1.75; 20 deep	10	O
L	Case drain fluid	DIN 3852 ⁴⁾	M22 x 1.5; 14 deep	2	O ⁵⁾
L ₁	Case drain fluid	DIN 3852 ⁴⁾	M22 x 1.5; 14 deep	2	X ⁵⁾
X	Pilot pressure	DIN 3852 ⁴⁾	M14 x 1.5; 12 deep	350	O
X	Pilot pressure with DG-control	DIN ISO 228 ⁴⁾	G 1/4 in	350	O

1) For the maximum tightening torques the general instructions on page 48 must be observed.

2) Depending on the application, short-term pressure spikes can occur. Consider this when selecting measuring equipment and fittings. Pressure values in bar absolute.

3) Only dimensions according to SAE J518, metric fastening thread deviating from the standard.

4) The spot face can be deeper than as specified in the standard.

5) Depending on the installation position, L or L₁ must be connected (see also installation instructions on pages 44, 46)

O = Must be connected (plugged on delivery)

X = Plugged (in normal operation)

Dimensions size 45

Before finalizing your design request a certified installation drawing. Dimensions in mm.

Drive shaft

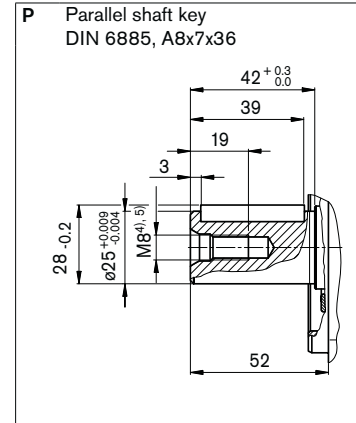
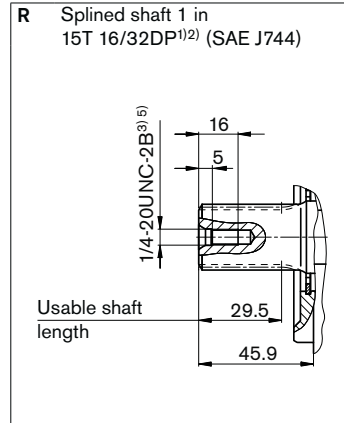
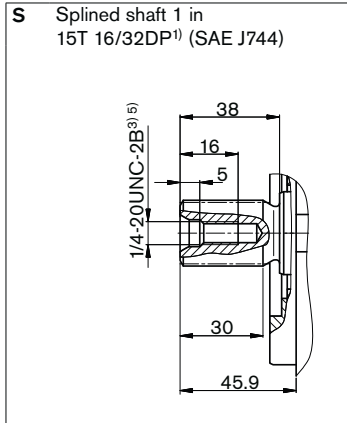

- 1) ANSI B92.1a, 30° pressure angle, flat root, side fit, tolerance class 5
- 2) Spline according to ANSI B92.1a, run out of spline is a deviation from standard.
- 3) Thread according to ASME B1.1
- 4) Thread according to DIN 13
- 5) For the maximum tightening torques the general instructions on page 48 must be observed.

Dimensions size 45

Two-point control, directly operated

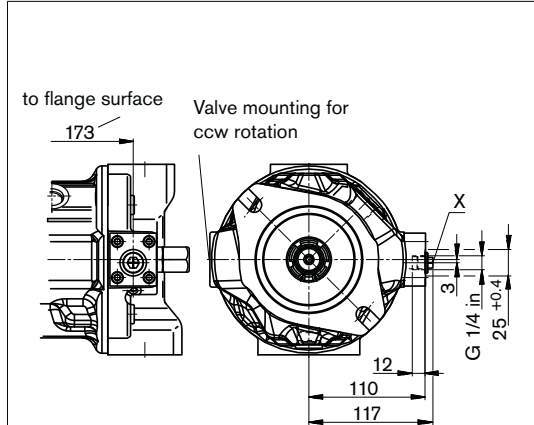

DFLR

Pressure, flow and power control

Before finalizing your design request a certified installation drawing. Dimensions in mm.

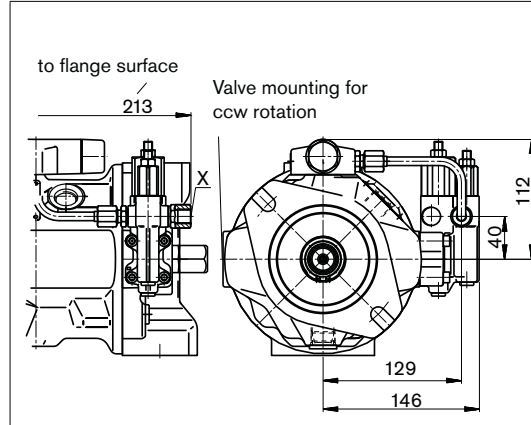

DR

Pressure control

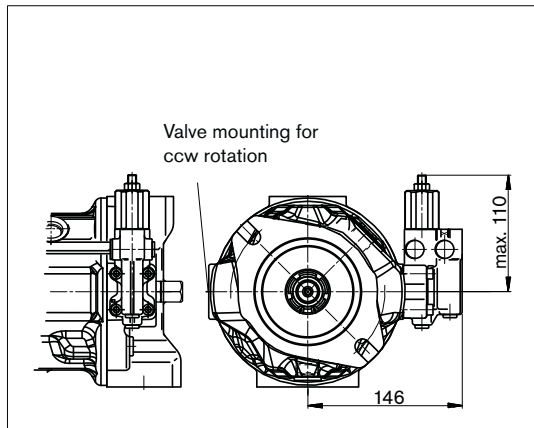

DRG

Pressure control, remotely operated

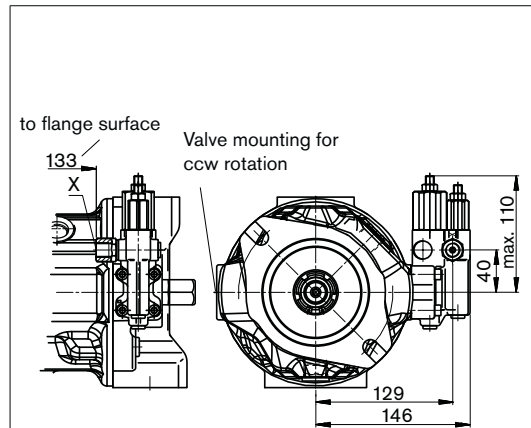

ED7. / ER7.

Electro-hydraulic pressure control

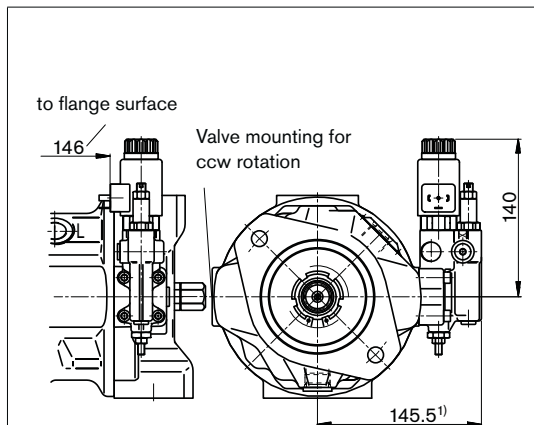

1) ER7.: 180.5 mm if using a sandwich plate pressure reducing valve.

Dimensions size 71

Before finalizing your design request a certified installation drawing. Dimensions in mm.

DFR/DFR1 – Pressure and flow control, hydraulic

Clockwise rotation

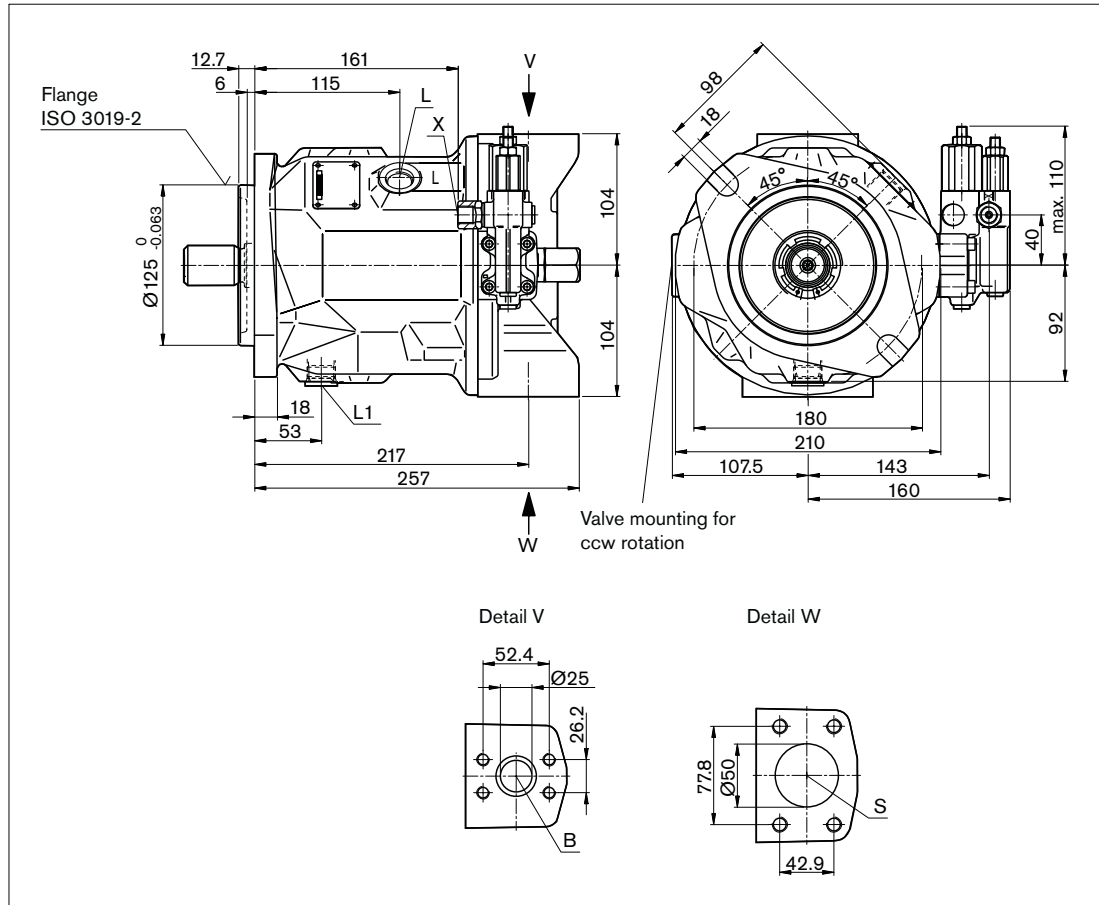

Ports

Designation	Port for	Standard	Size ¹⁾	Maximum pressure [bar] ²⁾	State
B	Service line, fastening thread	SAE J518 ³⁾ DIN 13	1 in M10 x 1.5; 17 deep	350	O
S	Suction line, fastening thread	SAE J518 ³⁾ DIN 13	2 in M12 x 1.75; 20 deep	10	O
L	Case drain fluid	DIN 3852 ⁴⁾	M22 x 1.5; 14 deep	2	O ⁵⁾
L ₁	Case drain fluid	DIN 3852 ⁴⁾	M22 x 1.5; 14 deep	2	X ⁵⁾
X	Pilot pressure	DIN 3852 ⁴⁾	M14 x 1.5; 12 deep	350	O
X	Pilot pressure with DG-control	DIN ISO 228 ⁴⁾	G 1/4 in	350	O

- 1) For the maximum tightening torques the general instructions on page 48 must be observed.
 - 2) Depending on the application, short-term pressure spikes can occur. Consider this when selecting measuring equipment and fittings. Pressure values in bar absolute.
 - 3) Only dimensions according to SAE J518, metric fastening thread deviating from the standard.
 - 4) The spot face can be deeper than as specified in the standard.
 - 5) Depending on the installation position, L or L₁ must be connected (see also installation instructions on pages 44, 46)
- O = Must be connected (plugged on delivery)
X = Plugged (in normal operation)

Dimensions size 71

Before finalizing your design request a certified installation drawing. Dimensions in mm.

Drive shaft

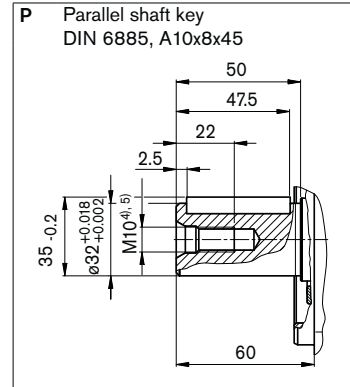
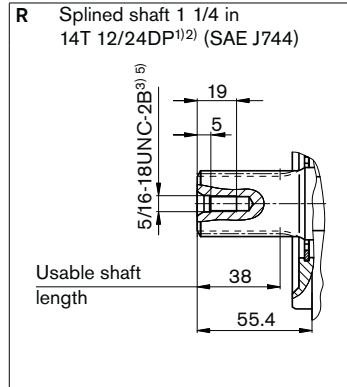
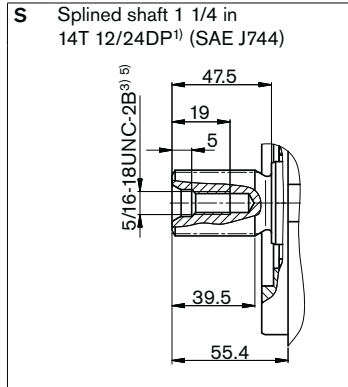

- 1) ANSI B92.1 a, 30° pressure angle, flat root, side fit, tolerance class 5
- 2) Spline according to ANSI B92.1a, run out of spline is a deviation from standard.
- 3) Thread according to ASME B1.1
- 4) Thread according to DIN 13
- 5) For the maximum tightening torques the general instructions on page 48 must be observed.

Dimensions size 71

Before finalizing your design request a certified installation drawing. Dimensions in mm.

DG

Two-point control, directly operated

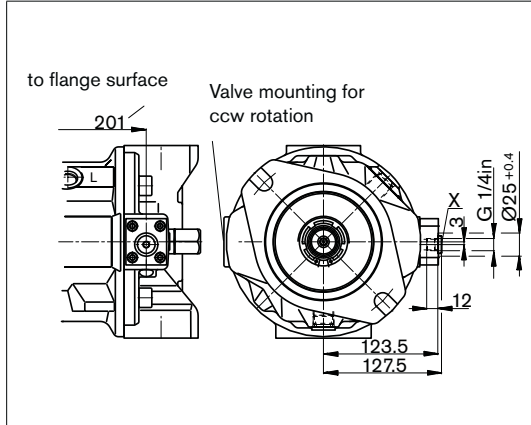

DFLR

Pressure, flow and power control

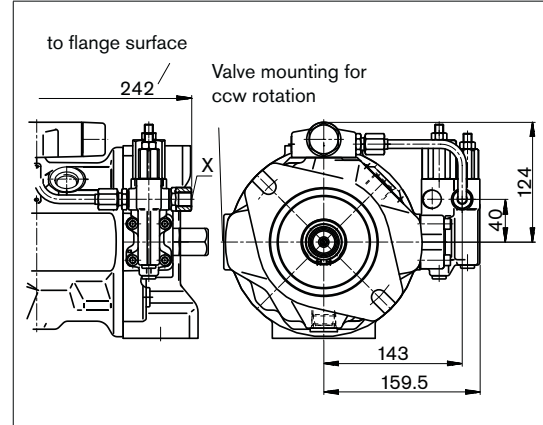

DR

Pressure control

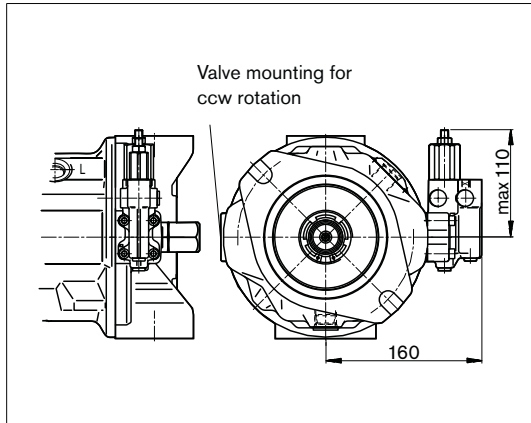

DRG

Pressure control, remotely operated

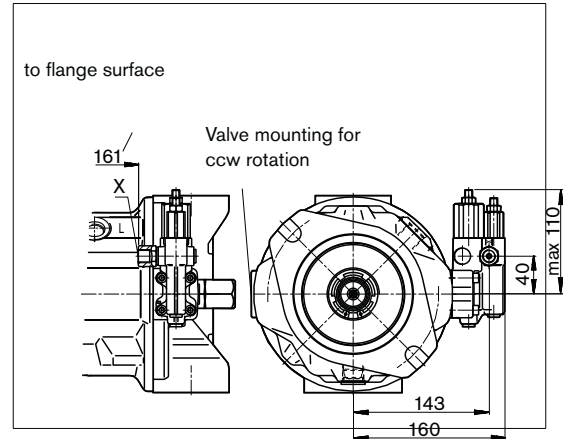

ED7. / ER7.

Electro-hydraulic pressure control

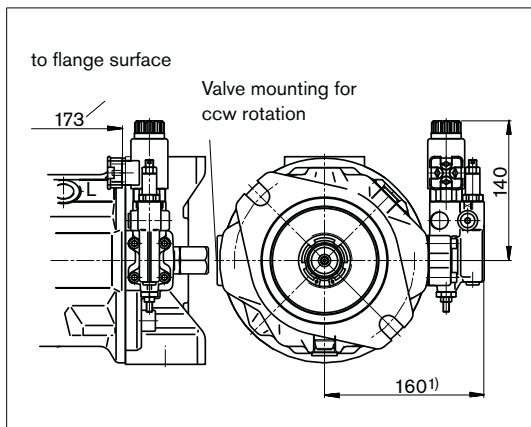

1) ER7.: 195 mm if using a sandwich plate pressure reducing valve.

Dimensions size 100

Before finalizing your design request a certified installation drawing. Dimensions in mm.

DFR/DFR1 – Pressure and flow control, hydraulic

Clockwise rotation

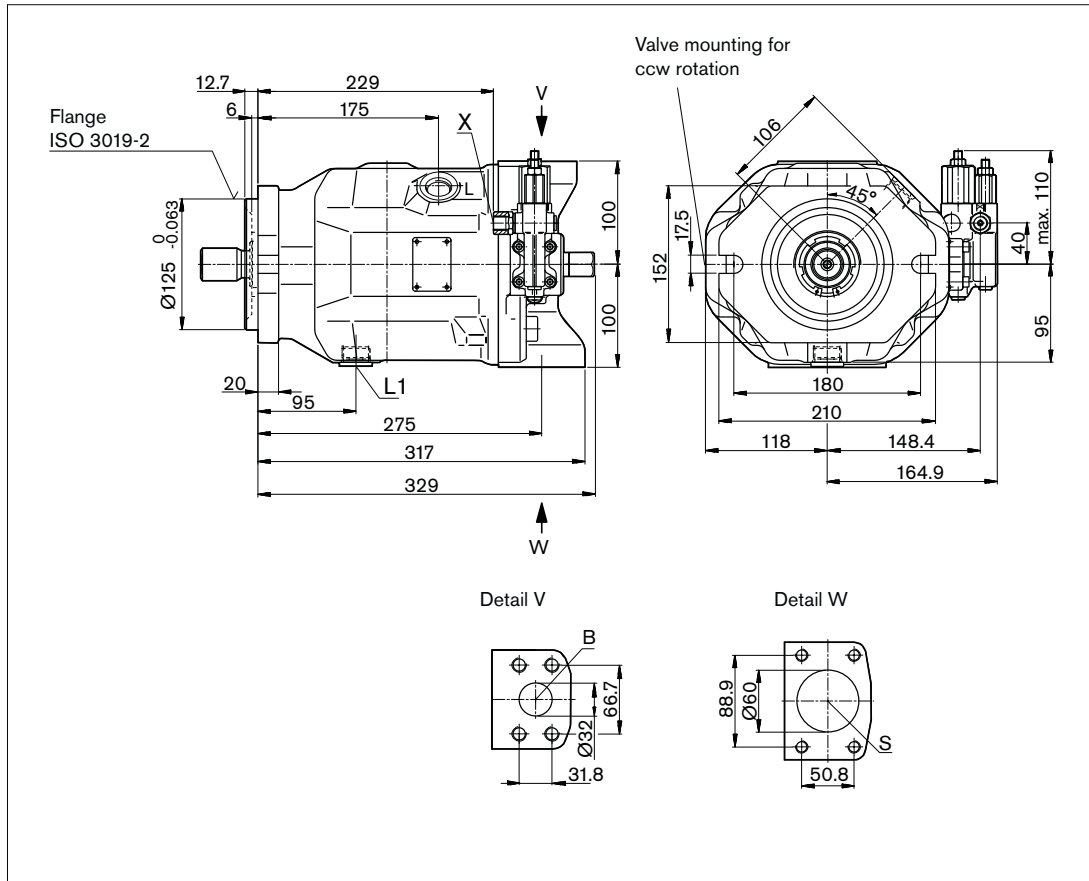

Ports

Designation	Port for	Standard	Size ¹⁾	Maximum pressure [bar] ²⁾	State
B	Service line, fastening thread	SAE J518 ³⁾ DIN 13	1 1/4 in M14 x 2; 19 deep	350	O
S	Suction line, fastening thread	SAE J518 ³⁾ DIN 13	2 1/2 in M12 x 1.75; 17 deep	10	O
L	Case drain fluid	DIN 3852 ⁴⁾	M27 x 2; 16 deep	2	O ⁵⁾
L ₁	Case drain fluid	DIN 3852 ⁴⁾	M27 x 2; 16 deep	2	X ⁵⁾
X	Pilot pressure	DIN 3852 ⁴⁾	M14 x 1.5; 12 deep	350	O
X	Pilot pressure with DG-control	DIN ISO 228 ⁴⁾	G 1/4 in	350	O

1) For the maximum tightening torques the general instructions on page 48 must be observed.

2) Depending on the application, short-term pressure spikes can occur. Consider this when selecting measuring equipment and fittings. Pressure values in bar absolute.

3) Only dimensions according to SAE J518, metric fastening thread deviating from the standard.

4) The spot face can be deeper than as specified in the standard.

5) Depending on the installation position, L or L₁ must be connected (see also installation instructions on pages 44, 46)

O = Must be connected (plugged on delivery)

X = Plugged (in normal operation)

Dimensions size 100

Before finalizing your design request a certified installation drawing. Dimensions in mm.

Drive shaft

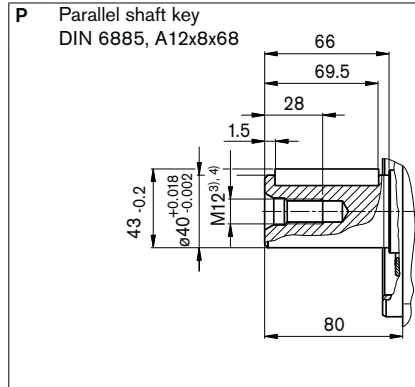
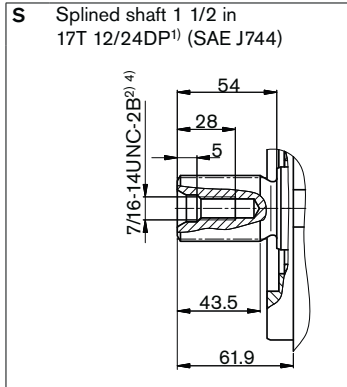

- 1) ANSI B92.1a, 30° pressure angle, flat root, side fit, tolerance class 5
- 2) Thread according to ASME B1.1
- 3) Thread according to DIN 13
- 4) For the maximum tightening torques the general instructions on page 48 must be observed.

Dimensions size 100

Before finalizing your design request a certified installation drawing. Dimensions in mm.

DG

Two-point control, directly operated

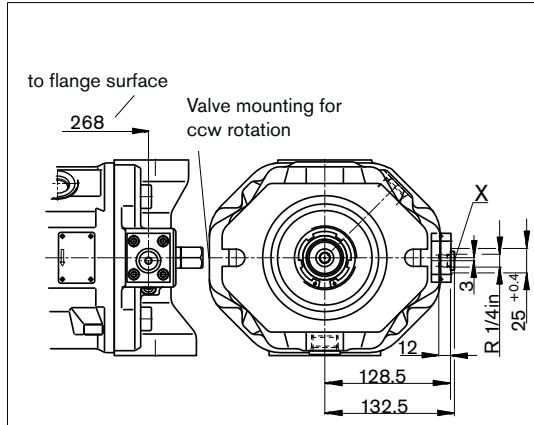

DFLR

Pressure, flow and power control

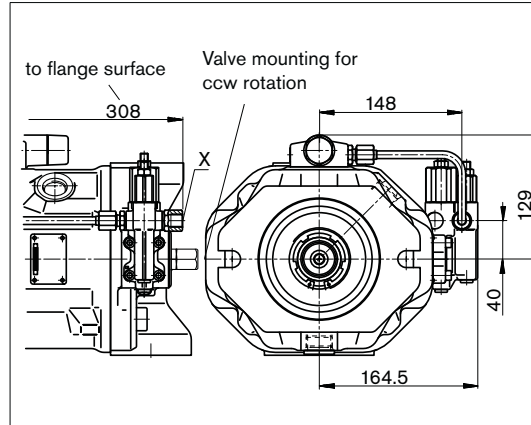

DR

Pressure control

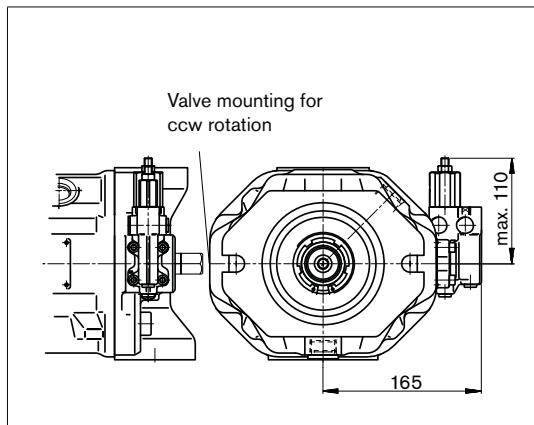

DRG

Pressure control, remotely operated

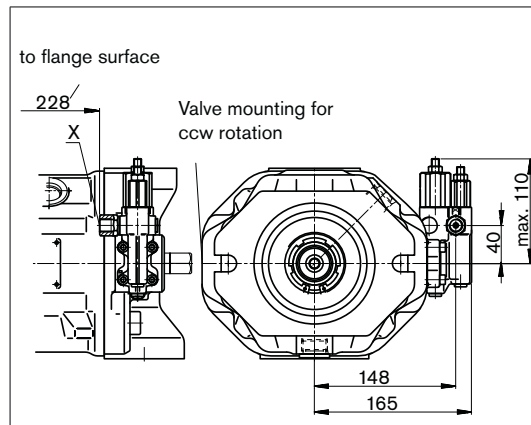

ED7. / ER7.

Electro-hydraulic pressure control

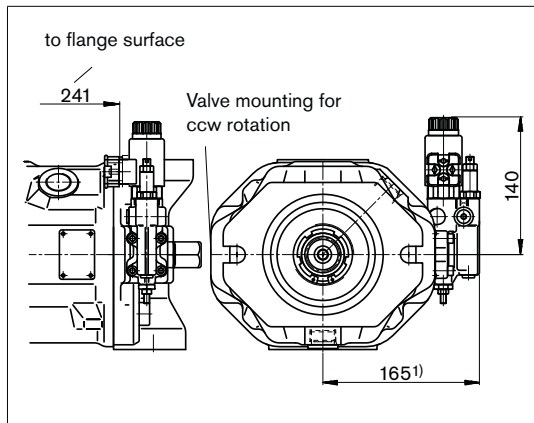

1) ER7.: 200 mm when using a sandwich plate pressure reducing valve.

Dimensions size 140

Before finalizing your design request a certified installation drawing. Dimensions in mm.

Drive shaft

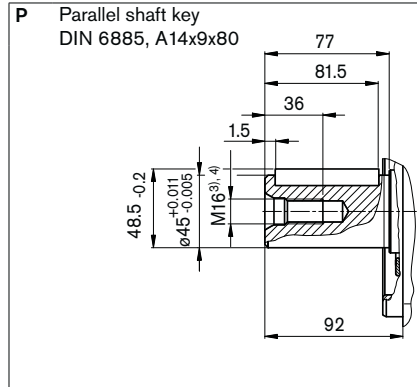
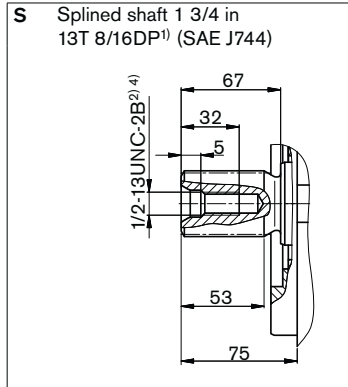

- 1) ANSI B92.1 a, 30° pressure angle, flat root, side fit, tolerance class 5
- 2) Thread according to ASME B1.1
- 3) Thread according to DIN 13
- 4) For the maximum tightening torques the general instructions on page 48 must be observed.

Dimensions size 140

Before finalizing your design request a certified installation drawing. Dimensions in mm.

DG

Two-point control, directly operated

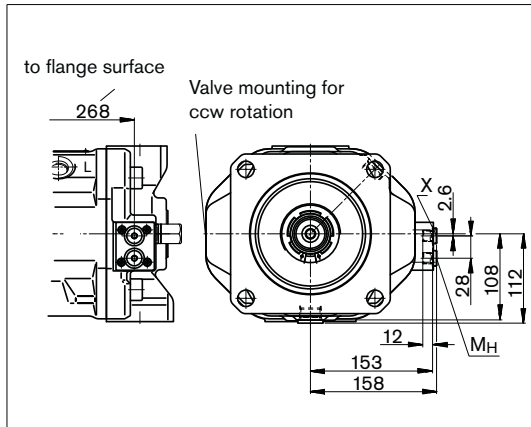

DFLR

Pressure, flow and power control

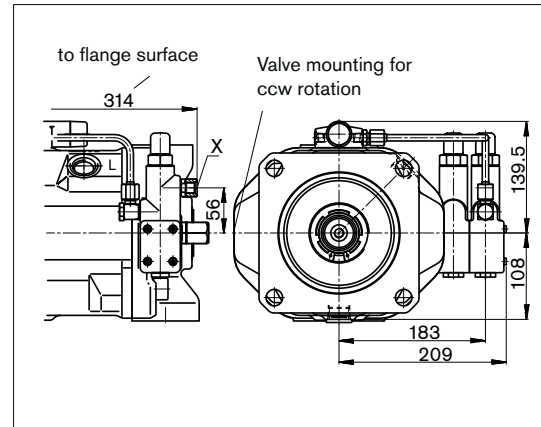

DR

Pressure control

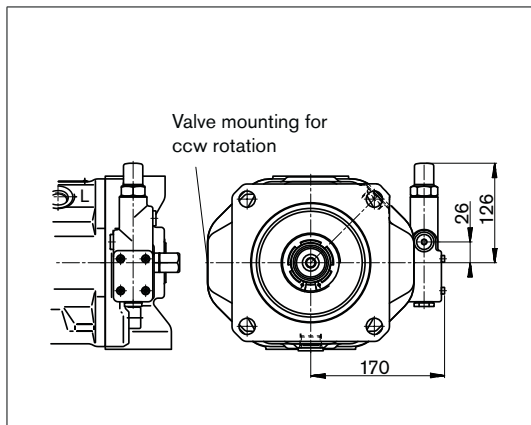

DRG

Pressure control, remotely operated

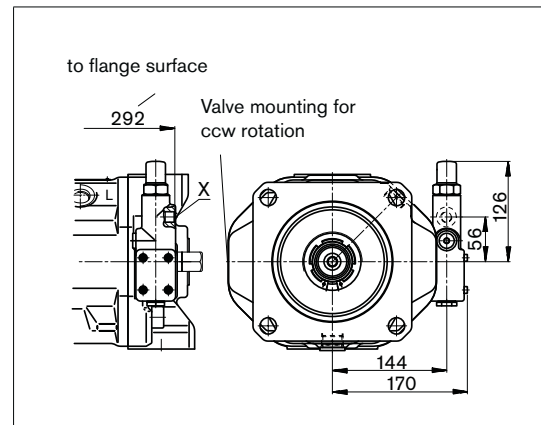

ED7. / ER7.

Electro-hydraulic pressure control

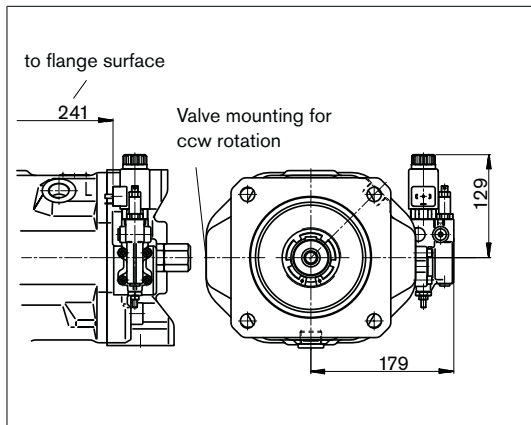

1) ER7.: 214 mm when using a sandwich plate pressure reducing valve.

Dimensions through drive

Before finalizing your design request a certified installation drawing. Dimensions in mm.

K01 flange ISO 3019-2 (SAE J744 - 82-2 (A))

Coupling for splined shaft according to ANSI B92.1a-1996

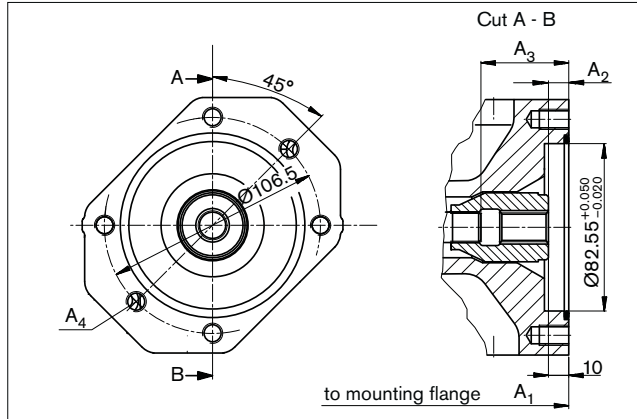

5/8 in 9T 16/32 DP¹⁾ (SAE J744 - 16-4 (A))

NG	A ₁	A ₂	A ₃	A ₄ ²⁾
18	182	10	43.3	M10 x 1.5, 14.5 deep
28	204	10	33.7	M10 x 1.5, 16 deep
45	229	10.7	53.4	M10 x 1.5, 16 deep
71	267	11.8	61.3	M10 x 1.5, 20 deep
100	338	10.5	65	M10 x 1.5, 16 deep
140	350	10.8	77.3	M10 x 1.5, 16 deep

K52 flange ISO 3019-2 (SAE J744 - 82-2 (A))

Coupling for splined shaft according to ANSI B92.1a-1996

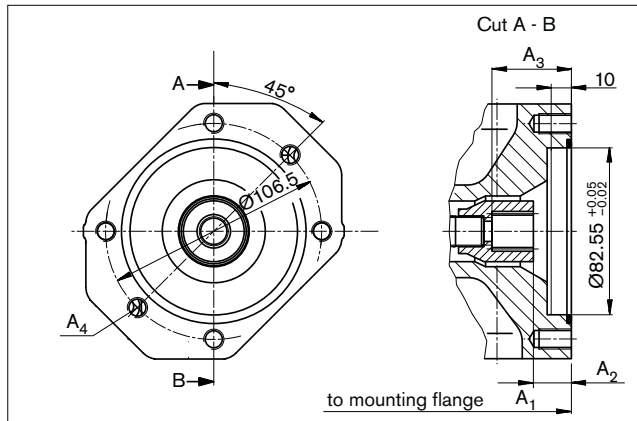

3/4 in 11T 16/32 DP¹⁾ (SAE J744 - 19-4 (A-B))

NG	A ₁	A ₂	A ₃	A ₄ ²⁾
18	182	18.8	38.7	M10 x 1.5, 14.5 deep
28	204	18.8	38.7	M10 x 1.5, 16 deep
45	229	18.9	38.7	M10 x 1.5, 16 deep
71	267	21.3	41.4	M10 x 1.5, 20 deep
100	338	19	38.9	M10 x 1.5, 16 deep
140	350	18.9	38.6	M10 x 1.5, 16 deep

K68 flange ISO 3019-2 (SAE J744 - 101-2 (B))

Coupling for splined shaft according to ANSI B92.1a-1996

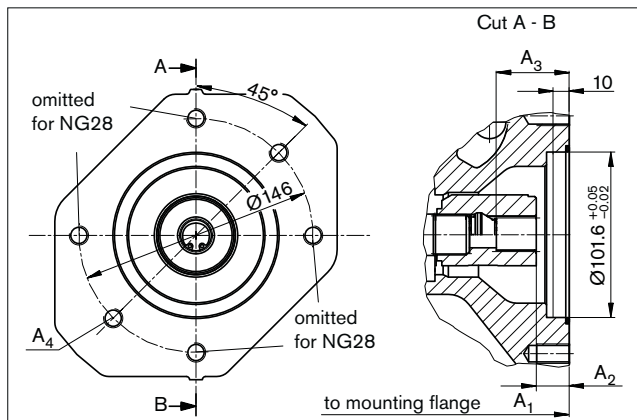

7/8 in 13T 16/32 DP¹⁾ (SAE J744 - 22-4 (B))

NG	A ₁	A ₂	A ₃	A ₄ ²⁾
28	204	17.8	41.7	M12 x 1.75, continuous
45	229	17.9	41.7	M12 x 1.75, 18 deep
71	267	20.3	44.1	M12 x 1.75, 20 deep
100	338	18	41.9	M12 x 1.75, 20 deep
140	350	17.8	41.6	M12 x 1.75, 20 deep

1) 30° pressure angle, flat root, side fit, tolerance class 5

2) Thread according to DIN 13, observe the general instructions on page 48 for the maximum tightening torques.

Dimensions through drive

Before finalizing your design request a certified installation drawing. Dimensions in mm.

K04 flange ISO 3019-2 (SAE J744 - 101-2 (B))

Coupling for splined shaft according to ANSI B92.1a-1996

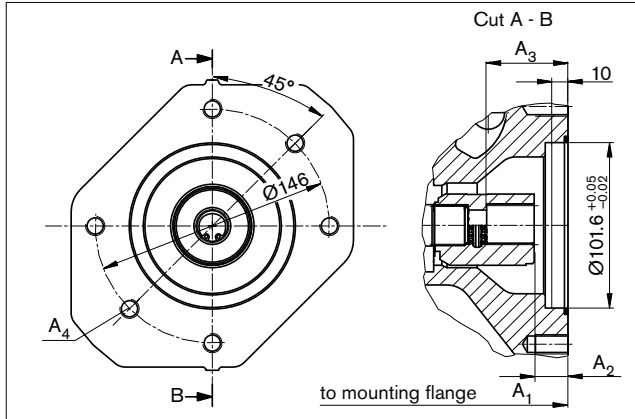

1 in 15T 16/32 DP¹⁾ (SAE J744 - 25-4 (B-B))

NG	A ₁	A ₂	A ₃	A ₄ ²⁾
45	229	18.4	46.7	M12 x 1.75, 18 deep
71	267	20.8	49.1	M12 x 1.75, 20 deep
100	338	18.2	46.6	M12 x 1.75, 20 deep
140	350	18.3	45.9	M12 x 1.75, 20 deep

K07 flange ISO 3019-2 (SAE J744 - 127-2 (C))

Coupling for splined shaft according to ANSI B92.1a-1996

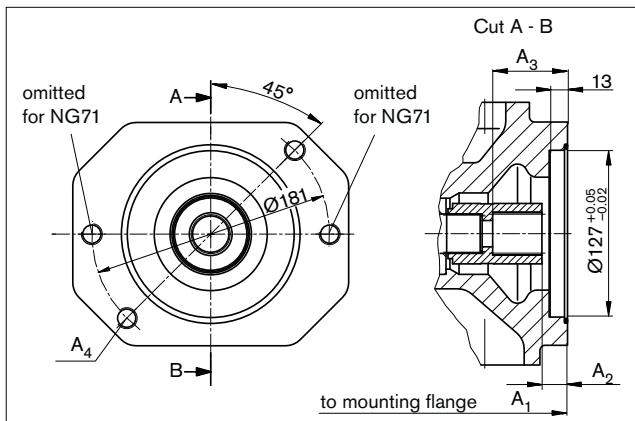

1 1/4 in 14T 12/24 DP¹⁾ (SAE J744 - 32-4 (C))

NG	A ₁	A ₂	A ₃	A ₄ ²⁾
71	267	21.8	58.6	M16 x 2, continuous
100	338	19.5	56.4	M16 x 2, continuous
140	350	19.3	56.1	M16 x 2, 24 deep

K24 flange ISO 3019-2 (SAE J744 - 127-2 (C))

Coupling for splined shaft according to ANSI B92.1a-1996

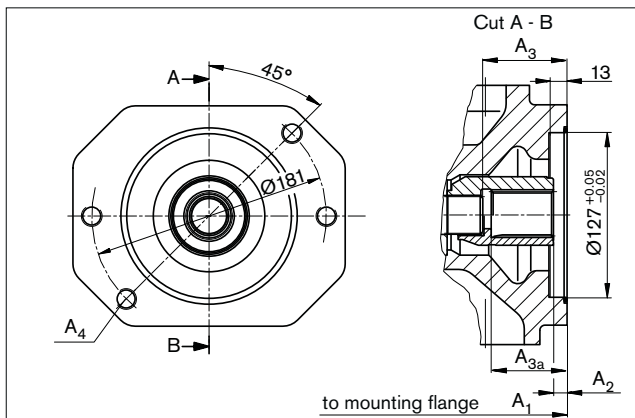

1 1/2 in 17T 12/24 DP¹⁾ (SAE J744 - 38-4 (C-C))

NG	A ₁	A ₂	A ₃ ³⁾	A _{3a} ⁴⁾	A ₄ ²⁾
100	338	10.5	65	-	M16 x 2, continuous
140	350	10.8	75	-	M16 x 2, 24 deep
	350	10.3	-	69.1	M16 x 2, 24 deep

1) 30° pressure angle, flat root, side fit, tolerance class 5

2) Thread according to DIN 13, observe the general instructions on page 48 for the maximum tightening torques.

3) Coupling **without** stop

4) Coupling **with** stop

Dimensions through drive

Before finalizing your design request a certified installation drawing. Dimensions in mm.

K17 flange ISO 3019-2 (SAE J744 - 152-4 (A))

Coupling for splined shaft according to ANSI B92.1a-1996

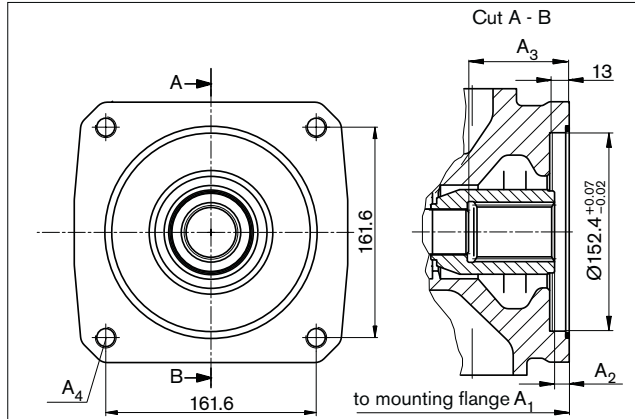

1 3/4 in 13T 8/16 DP¹⁾ (SAE J744 - 44-4 (D))

NG	A ₁	A ₂	A ₃	A ₄ ²⁾
140	350	11	77.3	M6 x 2, continuous

K57 Metric 4-hole flange for mounting an R4 radial piston pump (see RE 11263)

Coupling for metric shaft key

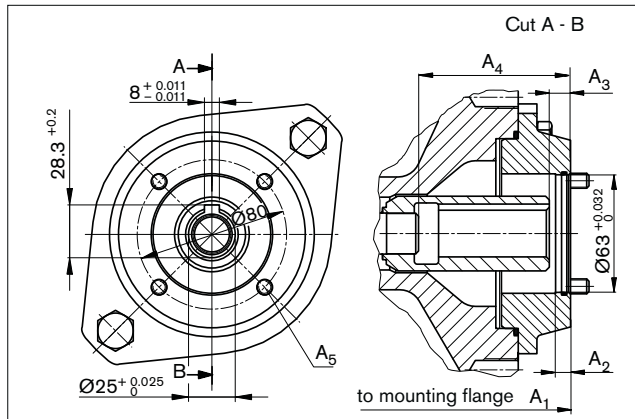

NG	A ₁	A ₂	A ₃	A ₄	A ₅ ³⁾
28	232	8	10.6	58.4	M8
45	257	8	11	81	M8
71	283	8	12.5	77	M10
100	354	8	10.5	81	M10
140	366	8	11	93	M8

1) 30° pressure angle, flat root, side fit, tolerance class 5

2) Thread according to DIN 13, observe the general instructions on page 48 for the maximum tightening torques.

3) Screws for mounting the radial piston motor are included in the delivery contents.

Dimensions through drive

Before finalizing your design request a certified installation drawing. Dimensions in mm.

KB2 flange ISO 3019-2 - 80A2SW

Coupling for splined shaft according to ANSI B92.1a-1996

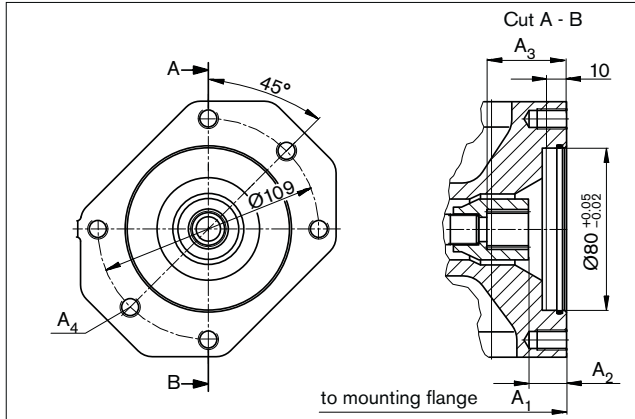

3/4 in 11T 16/32 DP¹⁾ (SAE J744 - 19-4 (A-B))

NG	A ₁	A ₂	A ₃	A ₄ ²⁾
18	182	18.8	38.7	M10 x 1.5, 14.5 deep
28	204	18.8	38.7	M10 x 1.5, 16 deep
45	229	18.9	38.7	M10 x 1.5, 16 deep
71	267	21.3	41.4	M10 x 1.5, 20 deep
100	338	19	38.9	M10 x 1.5, 20 deep
140	350	18.9	38.6	M10 x 1.5, 20 deep

KB3 flange ISO 3019-2 - 100A2SW

Coupling for splined shaft according to ANSI B92.1a-1996

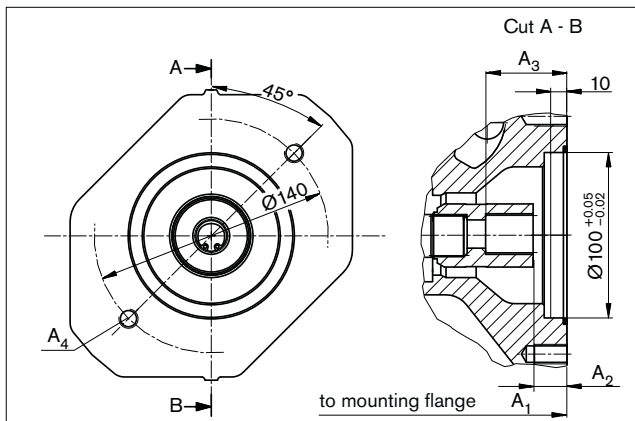

7/8 in 13T 16/32 DP¹⁾ (SAE J744 - 22-4 (B))

NG	A ₁	A ₂	A ₃	A ₄ ²⁾
28	204	17.8	41.7	M12 x 1.5, continuous
45	229	17.9	41.7	M12 x 1.5, continuous
71	267	20.3	44.1	M12 x 1.5, 20 deep
100	338	18	41.9	M12 x 1.5, 20 deep
140	350	17.8	41.6	M12 x 1.5, 20 deep

KB4 flange ISO 3019-2 - 100A2SW

Coupling for splined shaft according to ANSI B92.1a-1996

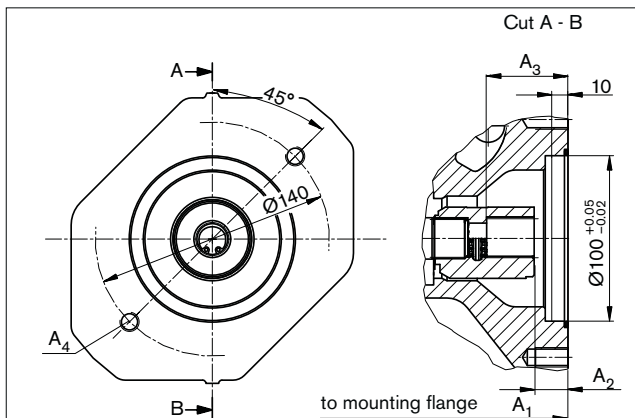

1 in 15T 16/32 DP¹⁾ (SAE J744 - 25-4 (B-B))

NG	A ₁	A ₂	A ₃	A ₄ ²⁾
45	229	18.4	46.7	M12 x 1.75, continuous
71	267	20.8	49.1	M12 x 1.75, 20 deep
100	338	18.2	46.6	M12 x 1.75, 20 deep
140	350	18.3	45.9	M12 x 1.75, 20 deep

1) 30° pressure angle, flat root, side fit, tolerance class 5

2) Thread according to DIN 13, observe the general instructions on page 48 for the maximum tightening torques.

Dimensions through drive

Before finalizing your design request a certified installation drawing. Dimensions in mm.

KB5 flange ISO 3019-2 - 125A2SW

Coupling for splined shaft according to ANSI B92.1a-1996

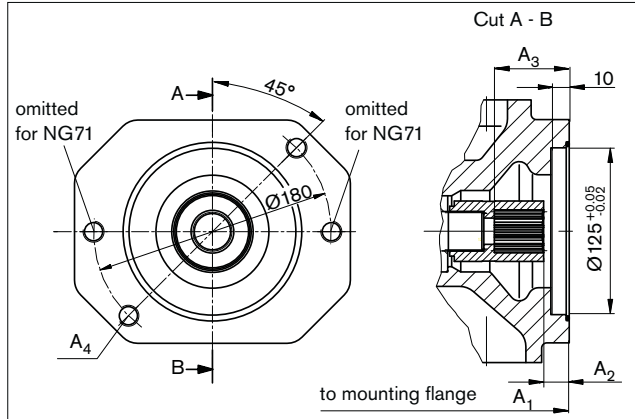

1 1/4 in 14T 12/24 DP¹⁾ (SAE J744 - 32-4 (C))

NG	A ₁	A ₂	A ₃	A ₄ ²⁾
71	267	21.8	58.6	M16 x 2, continuous
100	338	19.5	56.4	M16 x 2, continuous
140	350	19.3	56.1	M16 x 2, 24 deep

KB6 flange ISO 3019-2 - 125A2SW

Coupling for splined shaft according to ANSI B92.1a-1996

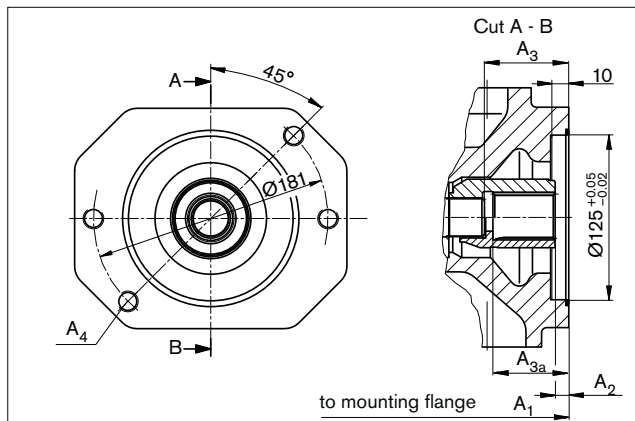

1 1/2 in 17T 12/24 DP¹⁾ (SAE J744 - 38-4 (C-C))

NG	A ₁	A ₂	A ₃ ³⁾	A _{3a} ⁴⁾	A ₄ ²⁾
100	338	10.5	65	-	M16 x 2, continuous
140	350	10.8	75	-	M16 x 2, 24 deep
	350	10.3	-	69.1	M16 x 2, 24 deep

KB7 flange ISO 3019-2 - 180B4HW

Coupling for splined shaft according to ANSI B92.1a-1996

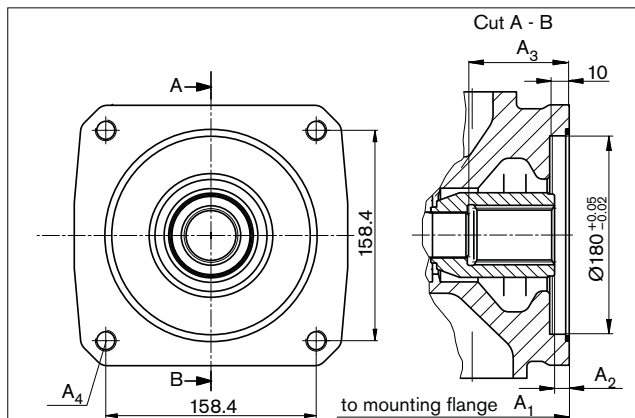

1 3/4 in 13T 8/16 DP¹⁾ (SAE J744 - 44-4 (D))

NG	A ₁	A ₂	A ₃	A ₄ ²⁾
140	350	11.3	77.3	M16 x 2, continuous

- 1) 30° pressure angle, flat root, side fit, tolerance class 5
- 2) Thread according to DIN 13, observe the general instructions on page 48 for the maximum tightening torques.
- 3) Coupling **without** stop
- 4) Coupling **with** stop

Summary mounting options

SAE – mounting flange

Through-drive ¹⁾			Mounting option – 2nd pump			
Flange ISO 3019-1	Coupling for splined shaft	Short des.	A10VO/31 NG (shaft)	A10V(S)O/5x NG (shaft)	Gear pump design (NG)	Through drive available for NG
82-2 (A)	5/8 in	K01	18 (U)	10 (U)	F (5 to 22)	18 to 140
	3/4 in	K52	18 (S, R)	10 (S) 18 (U) 18 (S, R)	–	18 to 140
101-2 (B)	7/8 in	K68	28 (S, R) 45 (U, W) ¹⁾	28 (S, R) 45 (U, W) ¹⁾	N/G (26 to 49)	28 to 140
	1 in	K04	45 (S, R) –	45 (S, R) 60, 63 (U, W) ²⁾	–	45 to 140
127-2 (C)	1 1/4 in	K07	71 (S, R) 100 (U) ³⁾	85 (U, W) ³⁾ 100 (U, W)	–	71 to 140
	1 1/2 in	K24	100 (S)	85 (S) 100 (S)	–	100 to 140
152-4 (4-hole D)	1 3/4 in	K17	140 (S)	–	–	140

1) Not for main pump NG28 with K68

2) Not for main pump NG45 with K04

3) Not for main pump NG71 with K07

ISO – mounting flange

Through-drive ¹⁾			Mounting option – 2nd pump			
Flange ISO 3019-2	Coupling for splined shaft	Short des.	A10VO/31 NG (shaft)	A10V(S)O/5x NG (shaft)	Gear pump design (NG)	Through drive available for NG
80-2	3/4 in	KB2	18 (S, R)	10 (S)	–	18 to 140
100-2	7/8 in	KB3	28 (S, R)	–	–	28 to 140
	1 in	KB4	45 (S, R)	–	–	45 to 140
125-2	1 1/4 in	KB5	71 (S, R)	–	–	71 to 140
	1 1/2 in	KB6	100 (S)	–	–	100 to 140
180-4 (4-hole B)	1 3/4 in	KB7	140 (S)	–	–	140

Shaft key

Through-drive ¹⁾			Mounting option – 2nd pump			
Flange ISO 3019-2	Coupling for shaft key	Short des.	A10VO/31 NG (shaft)	A10V(S)O/5x NG (shaft)	Radial piston pump	Through drive available for NG
80-2	3/4 in	K57	–	–	R4	28 to 140

Combination pumps A10VO + A10VO

Before finalizing your design request a certified installation drawing. Dimensions in mm.

When using combination pumps it is possible to have multiple, mutually independent circuits without the need for a splitter gearbox.

When ordering combination pumps the model codes for the first and the second pump must be joined by a "+".

Order example:

A10VSO100DFR1/31R-VSB12K04+
A10VSO45DFR/31R-VSA12N00

If no further pumps are to be factory-mounted, the simple type code is sufficient. Included in the delivery contents of the pump with through drive are then: coupling and seal, with plastic cover to prevent penetration by dust and dirt.

It is permissible to use a combination of two single pumps of the same size (tandem pump), considering a dynamic mass acceleration force of maximum 10 g (= 98.1 m/s²) without an additional support bracket.

Each through drive is plugged with a **non-pressure-resistant** cover. Before commissioning the units, they must therefore be equipped with a pressure-resistant cover.

Through drives can also be ordered with pressure-resistant covers. Please specify in clear text.

For combination pumps comprising more than two pumps, the mounting flange must be calculated for the permissible moment of inertia.

Permissible mass moment of inertia

NG			18	28	45	71	100	140
Permissible mass moment of inertia	static	T _m Nm	500	880	1370	2160	3000	4500
	dynamic at 10 g (98.1 m/s ²)	T _m Nm	50	88	137	216	300	450
Mass with through-drive plate	m	kg	14	19	25	39	54	68
Mass without through drive (e.g. 2nd pump)	m	kg	12	15	21	33	45	60
Distance center of gravity	l	mm	90	110	130	150	160	160

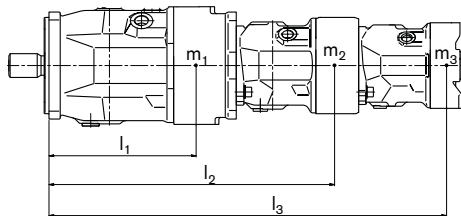

m_1, m_2, m_3 Mass of pumps [kg]

l_1, l_2, l_3 Distance center of gravity [mm]

$$T_m = (m_1 \cdot l_1 + m_2 \cdot l_2 + m_3 \cdot l_3) \cdot \frac{1}{102} \text{ [Nm]}$$

Connector for solenoids

HIRSCHMANN DIN EN 175 301-803-A /ISO 4400

without bidirectional suppressor diode _____ H

Type of protection according to DIN/EN 60529 _____ IP65

The sealing ring in the screw cable fitting is suitable for line diameters of 4.5 mm to 10 mm.

The line connector is not included in the delivery contents.

This can be supplied by Bosch Rexroth on request.

Bosch Rexroth material number: R902602623

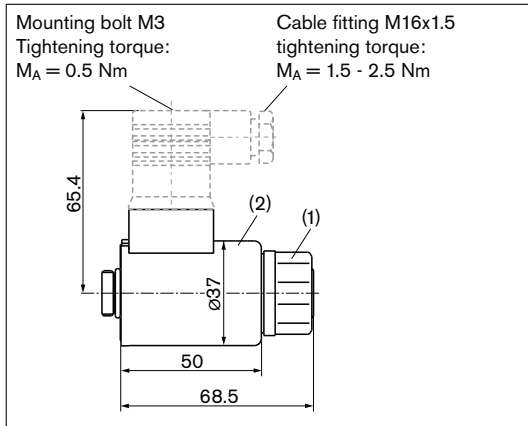

Changing connector position

If necessary, you can change the position of the connector by turning the solenoid.

To do this, proceed as follows:

1. Loosen the mounting nut (1) of the solenoid. To do this, turn the mounting nut (1) one revolution counter-clockwise.
2. Turn the solenoid body (2) to the desired position.
3. Retighten the mounting nut of the solenoid. Tightening torque: 5+1 Nm. (size WAF26, 12-pt DIN 3124)

On delivery, the position of the connector may differ from that shown in the brochure or drawing.

Device plug on solenoid
according to DIN 43650

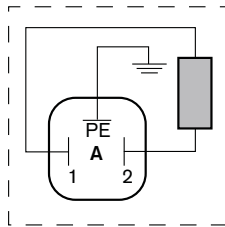

line connector
DIN EN 175301-803-A
Wiring screw connector
M 16x1.5

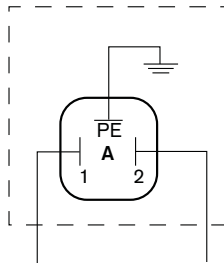

Installation instructions

General

The axial piston unit must be filled with hydraulic fluid and air bled during commissioning and operation. This must also be observed following a longer standstill as the axial piston unit empty via the hydraulic lines.

Especially with the installation position "drive shaft upwards" or "drive shaft downward", attention must be paid to a complete filling and air bleeding since there is a risk, for example, of dry running.

The case drain fluid in the motor housing must be directed to the reservoir via the highest case drain port (L₁, L₂, L₃).

For combinations of multiple units, make sure that the respective case pressure in each unit is not exceeded. In the event of pressure differences at the case drain ports of the units, the shared case drain line must be changed so that the minimum permissible case pressure of all connected units is not exceeded in any situation. If this is not possible, separate case drain lines must be laid if necessary.

To achieve favorable noise values, decouple all connecting lines using elastic elements and avoid above-reservoir installation.

In all operating conditions, the suction line and case drain line must flow into the reservoir below the minimum fluid level. The permissible suction height h_S is a result of the overall pressure loss, but may not be greater than $h_{S \max} = 800$ mm. The minimum suction pressure at port S must also not fall below 0.8 bar absolute during operation.

Installation position

See the following examples 1 to 12.

Additional installation positions are available upon request.

Recommended installation positions: 1 and 3.

Below-reservoir installation (standard)

Below-reservoir installation means the axial piston unit is installed outside of the reservoir below the minimum fluid level.

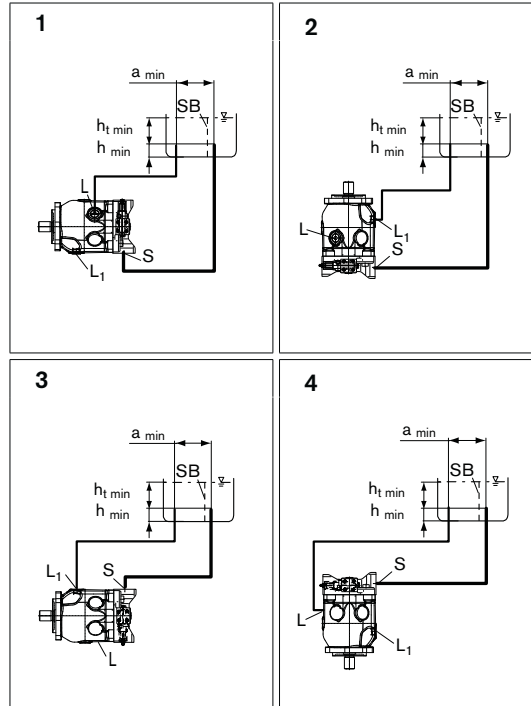

Installation position	Air bleed	Filling
1	L	S + L ₁
2	L ₁	S + L
3	L ₁	S + L
4	L	S + L ₁

Key, see page 45.

Installation instructions

Above-reservoir installation

Above-reservoir installation means the axial piston unit is installed above the minimum fluid level of the reservoir. To prevent the axial piston unit from draining, a height difference $h_{ES\ min}$ of at least 25 mm at port L_1 is required in installation position 6.

Observe the maximum permissible suction height $h_{S\ max} = 800\ mm$.

A check valve in the case drain line is only permissible in individual cases. Consult us for approval.

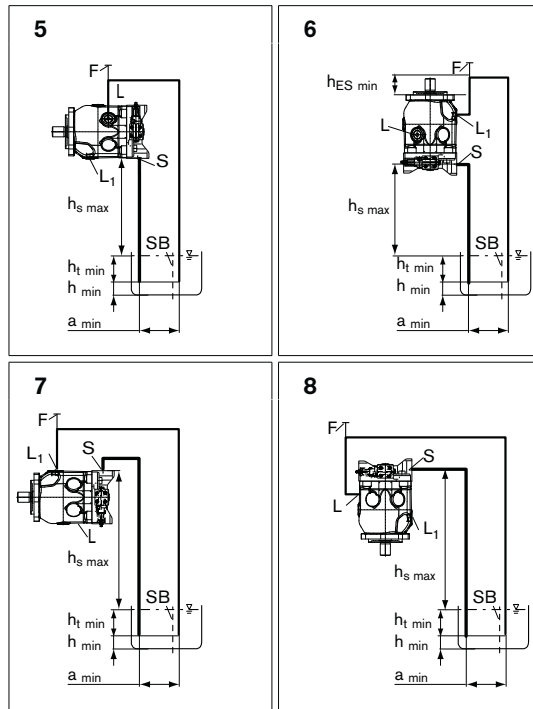

Installation position	Air bleed	Filling
5	F	L (F)
6	F	L_1 (F)
7	F	S + L_1 (F)
8	F	S + L (F)

Inside-reservoir installation

Inside-reservoir installation is when the axial piston unit is installed in the reservoir below the minimum fluid level. The axial piston unit is completely below the hydraulic fluid.

If the minimum fluid level is equal to or below the upper edge of the pump, see chapter "Above-reservoir installation".

Axial piston units with electrical components (e.g. electric control, sensors) may not be installed in a reservoir below the fluid level.

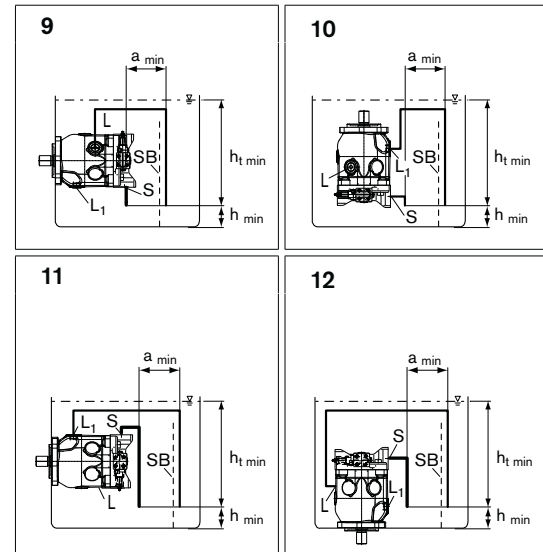

Installation position	Air bleed	Filling
9	L	L, L_1
10	L_1	L, L_1
11	L_1	S + L, L_1
12	L	S + L, L_1

- S** Suction port
- F** Filling / air bleeding
- L, L_1** Case drain port
- SB** Baffle (baffle plate)
- $h_{t\ min}$** Minimum necessary immersion depth (200 mm)
- h_{min}** Minimum necessary spacing to reservoir bottom (100 mm)
- $h_{ES\ min}$** Minimum necessary height needed to protect the axial piston unit from draining (25 mm).
- $h_{S\ max}$** Maximum permissible suction height (800 mm)
- a_{min}** When designing the reservoir, ensure adequate distance between the suction line and the case drain line. This prevents the heated, return flow from being drawn directly back into the suction line.

Notes

Notes

General instructions

- The A10VSO pump is designed to be used in open circuit.
- Project planning, installation and commissioning of the axial piston unit require the involvement of qualified personnel.
- Before operating the axial piston unit, please read the appropriate instruction manual thoroughly and completely. If necessary, request these from Bosch Rexroth.
- During and shortly after operation, there is a risk of burns on the axial piston unit and especially on the solenoids. Take appropriate safety measures (e.g. by wearing protective clothing).
- Depending on the operating conditions of the axial piston unit (operating pressure, fluid temperature), the characteristics may shift.
- Service line ports:
 - The ports and fastening threads are designed for the specified maximum pressure. The machine or system manufacturer must ensure that the connecting elements and lines correspond to the specified application conditions (pressure, flow, hydraulic fluid, temperature) with the necessary safety factors.
 - The service line ports and function ports are only designed to accommodate hydraulic lines.
- Pressure cut-off and pressure control do not provide security against pressure overload. A separate pressure relief valve is to be provided in the hydraulic system.
- The data and notes contained herein must be adhered to.
- The product is not approved as a component for the safety concept of a general machine according to DIN EN ISO 13849.
- The following tightening torques apply:
 - Fittings: Observe the manufacturer's instruction regarding the tightening torques of the used fittings.
 - Mounting bolts: For mounting bolts with metric ISO thread according to DIN 13 or thread according to ASME B1.1, we recommend checking the tightening torque individually according to VDI 2230.
 - Female threads in axial piston unit: The maximum permissible tightening torques $M_{G \max}$ are maximum values for the female threads and must not be exceeded. For values, see the following table.
 - Threaded plugs: For the metal threaded plugs supplied with the axial piston unit, the required tightening torques of the threaded plugs M_V apply. For values, see the following table.

Ports		Maximum permissible tightening torque for female threads $M_{G \max}$	Required tightening torque for threaded plugs M_V	Size of hexagon socket of threaded plugs
Standard	Thread size			
DIN 3852	M14 x 1.5	80 Nm	45 Nm	6 mm
	M16 x 1.5	100 Nm	50 Nm	8 mm
	M18 x 1.5	140 Nm	60 Nm	8 mm
	M22 x 1.5	210 Nm	80 Nm	10 mm
	M27 x 2	330 Nm	135 Nm	12 mm
DIN ISO 228	G 1/4 in	70 Nm	-	-

© This document, as well as the data, specifications and other information set forth in it, are the exclusive property of Bosch Rexroth AG. It may not be reproduced or given to third parties without its consent.

The data specified above only serve to describe the product. No statements concerning a certain condition or suitability for a certain application can be derived from our information. The information given does not release the user from the obligation of own judgment and verification. It must be remembered that our products are subject to a natural process of wear and aging.
Subject to change.