

Electric Drives
and Controls

Hydraulics

Linear Motion and
Assembly Technologies

Pneumatics

Service

Rexroth
Bosch Group

4/3 proportional directional control valve, without position control

RE 29049/09.05 1/12

Type 4WRBA..E.. /..W..

Nominal size 6, 10
Unit series 2X
Maximum working pressure P, A, B 315 bar, T 250 bar
Nominal flow rate Q_{nom} 6...28 l/min (NG6), 32...63 l/min (NG10)

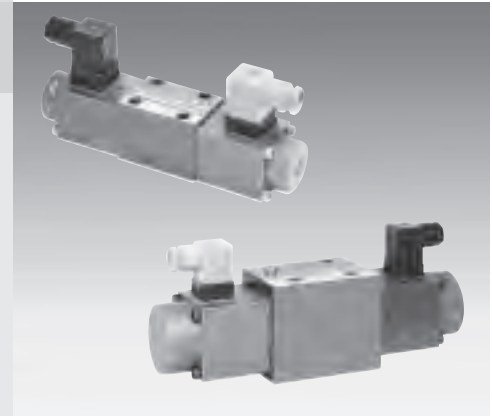

Overview of Contents

Contents	Page
Features	1
Ordering data	2
Preferred types	2
Symbols	2
Function, sectional diagram	3
Accessories	4
Technical data	5 and 6
External trigger electronics	7 and 8
Characteristic curves	9 and 10
Unit dimensions	11 and 12

Features

- Directly controlled NG6 and NG10 valves with positive overlap and external valve electronics
- Actuated on both sides, standard symbols E and W
- Adjustable by means of the solenoid current, see Characteristic Curve, Technical Data and the selected valve electronics
- Solenoid version $I_{max} = 2.5 A$
- For subplate attachment, mounting hole configuration NG6 to ISO 4401-03-02-0-94, NG10 to ISO 4401-05-04-0-94
- Subplates as per catalog sheet, RE 45053 for NG6, RE 45055 for NG10 (order separately)
- Plug-in connector to DIN 43650-AM2 included in scope of delivery
- External trigger electronics with ramps and valve calibration in the following versions/designs (order separately)
 - Module, setpoint 0...±10 V, RE 30229
 - Europe card format, setpoint 0...±10 V, RE 30230

Ordering data

4WRBA				2X	/	G24	N9	Z4	/	M	*
-------	--	--	--	----	---	-----	----	----	---	---	---

Further information in plain text

M = NBR seals, suitable for mineral oils (HL, HLP) to DIN 51524

Z4 = **Electrical connection**
With unit plug to DIN 43650-AM2 **with** plug-in connector, included in scope of delivery

N9 = **Manual auxiliary override** (covered)

G24 = **Voltage supply of trigger electronics**
+24 V DC

2X = **Unit series**
(installation and connection dimensions unchanged)

Nominal flow rate ($\Delta p = 5$ bar per metering edge)

N6	
07 =	6 l/min
15 =	14 l/min
30 =	28 l/min
NG10	
32 =	32 l/min
64 =	63 l/min

4/3 proportional directional control valve, without position control

NG6 = 6
NG10 = 10

Symbols
4/3-way version

= E

= W

Preferred types

NG6 Solenoid 2.5 A		NG10 Solenoid 2.5 A	
Type	Material Number	Type	Material Number
4WRBA6E07-2X/G24N9Z4/M	0 811 404 123	4WRBA10E32-2X/G24N9Z4/M	0 811 404 830
4WRBA6E15-2X/G24N9Z4/M	0 811 404 115	4WRBA10E64-2X/G24N9Z4/M	0 811 404 832
4WRBA6E30-2X/G24N9Z4/M	0 811 404 114	4WRBA10W32-2X/G24N9Z4/M	0 811 404 831
4WRBA6W07-2X/G24N9Z4/M	0 811 404 125	4WRBA10W64-2X/G24N9Z4/M	0 811 404 833
4WRBA6W15-2X/G24N9Z4/M	0 811 404 117		
4WRBA6W30-2X/G24N9Z4/M	0 811 404 116		

Symbols

Actuation:

..E..

..W..

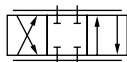
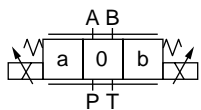

Function, sectional diagram

General

Directly operated type 4WRBA 4/3 proportional directional control valves without position control are available in nominal sizes 6 and 10.

Hysteresis is < 4% for the NG6 and < 6% for the NG10.

The valve amplifier electronics are available in various designs for 2.5 A solenoids. The operating limits are largely determined by the available magnetic force, see characteristic curves.

Basic principle

To adjust the oil flow rate, a setpoint is set in the trigger electronics. Based on the polarity of this setpoint, the electronics control the solenoid coil "a" or "b" with regulated PWM (pulse-width-modulated) current. The current is modulated with a dither, ensuring low hysteresis. The proportional solenoid converts the current to a mechanical force, with which an armature plunger acts on a spool to push against the spring. If the magnetic force and the spring force are the same, this produces a spool position in conformity with the spring characteristic curve. If the drop in pressure is minimal (< 30 bar) the throttling function takes effect, if the pressure drop is greater, the operating limits (see characteristic curves) must be observed.

The pressure drop at the valve is reliably limited by the use of an external pressure compensator with shuttle valve.



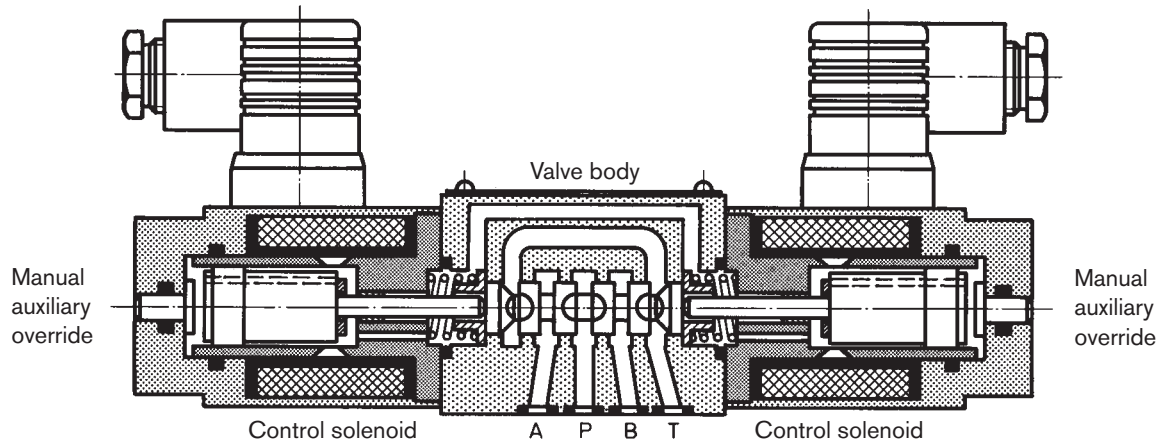

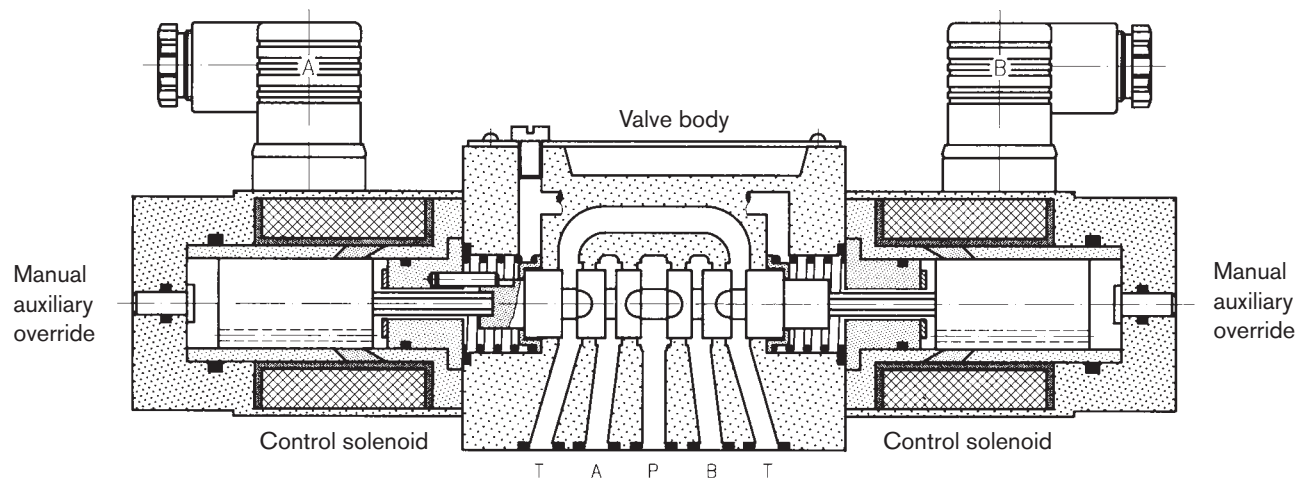

NG6



NG10

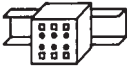

Accessories

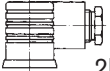
Type		Material Number		
(4x)  ISO 4762-M5x30-10.9	Cheese-head bolts NG6	2 910 151 166		
(4x)  ISO 4762-M6x35-10.9	Cheese-head bolts NG10	2 910 151 207		
Module 	 VT-MSPA2-525-10/V0 (2.5 A)	RE 30229	0 811 405 106	
Europe card 	 VT-VSPA2-525-10/V0/RTP (2.5 A)	RE 30230	0 811 405 080	
Plug-in connector 	Plug-in connector 2P+PE (M16x1.5) included in scope of delivery, see also RE 08008			

Testing and service equipment

Test box type VT-PE-TB1, see RE 30063

Test adapter type VT-PA-3, see RE 30070

Current measuring adapter type VT-PA-5, see RE 30073

Technical data

General

Construction	Spool-type valve	
Actuation	Proportional solenoid without position control, external amplifier	
Connection type	Subplate, mounting hole configuration NG6 (ISO 4401-03-02-0-94), NG10 (ISO 4401-05-04-0-94)	
Mounting position	Optional	
Ambient temperature range	°C	-20...+50
Weight	NG6 kg	2.6
	NG10 kg	7.7
Vibration resistance, test condition	Max. 25 g, shaken in 3 dimensions (24 h)	

Hydraulic (measured with HLP 46, $\vartheta_{oil} = 40^\circ\text{C} \pm 5^\circ\text{C}$)

Pressure fluid	Hydraulic oil to DIN 51524...535, other fluids after prior consultation					
Viscosity range	recommended	mm ² /s	20...100			
	max. permitted	mm ² /s	10...800			
Pressure fluid temperature range	°C	-20...+80				
Maximum permitted degree of contamination of pressure fluid Purity class to ISO 4406 (c)	Class 18/16/13 ¹⁾					
Direction of flow, see symbol	NG6		NG10			
Nominal flow rate (at $\Delta p = 5$ bar)*	l/min	6	28 (per channel)	32	63 (per channel)	
Leakage per metering edge ($\Delta p = 100$ bar)	cm ³ /min		A → T = 80		A → T = 80	
			B → T = 80		B → T = 80	
Leakage drain ($\Delta p = 5$ bar)	l/min		A → T = 0.8...1.6		A → T = 0.4...0.8	
			B → T = 0.8...1.6		B → T = 0.4...0.8	
Max. working pressure	bar	Port P, A, B: 315				
		Port T: 250				

¹⁾ The purity classes stated for the components must be complied with in hydraulic systems. Effective filtration prevents problems and also extends the service life of components. For a selection of filters, see catalog sheets RE 50070, RE 50076 and RE 50081.

* Nominal flow

This is always based on a pressure differential of $\Delta p = 5$ bar at the throttling point. Where other pressure differentials are involved, the flow is calculated according to the following formula:

$$Q_x = Q_{nom} \cdot \sqrt{\frac{\Delta p_x}{5}}$$

However, the **operating limits** must be borne in mind. If they are exceeded, the ensuing flow forces lead to uncontrollable spool movements. **Pressure compensators** are used to reliably limit Δp .

Technical data

Electrical

Cyclic duration factor	%	100	
Degree of protection		IP 65 to DIN 40050 and IEC 14434/5	
Solenoid connection		Unit plug DIN 43650/ISO 4400, M16x1.5 (2P+PE)	
Valve with solenoid type		NG6	NG10
Max. solenoid current I_{max}	A	2.5	2.5
Coil resistance R_{20}	Ω	3	5.8
Max. power consumption at 100% load and operating temperature	VA	30	55

Static/Dynamic¹⁾

Hysteresis	%	≤ 4	≤ 6
Range of inversion	%	≤ 3	≤ 4
Manufacturing tolerance	%	≈ 10	≈ 10
Response time 100% signal change	ms	70	100

¹⁾ All characteristic values ascertained using amplifier 0 811 405 080 for the 2.5 A solenoid.

Valve with external trigger electronics (module, RE 30229)

Circuit diagram/pin assignment

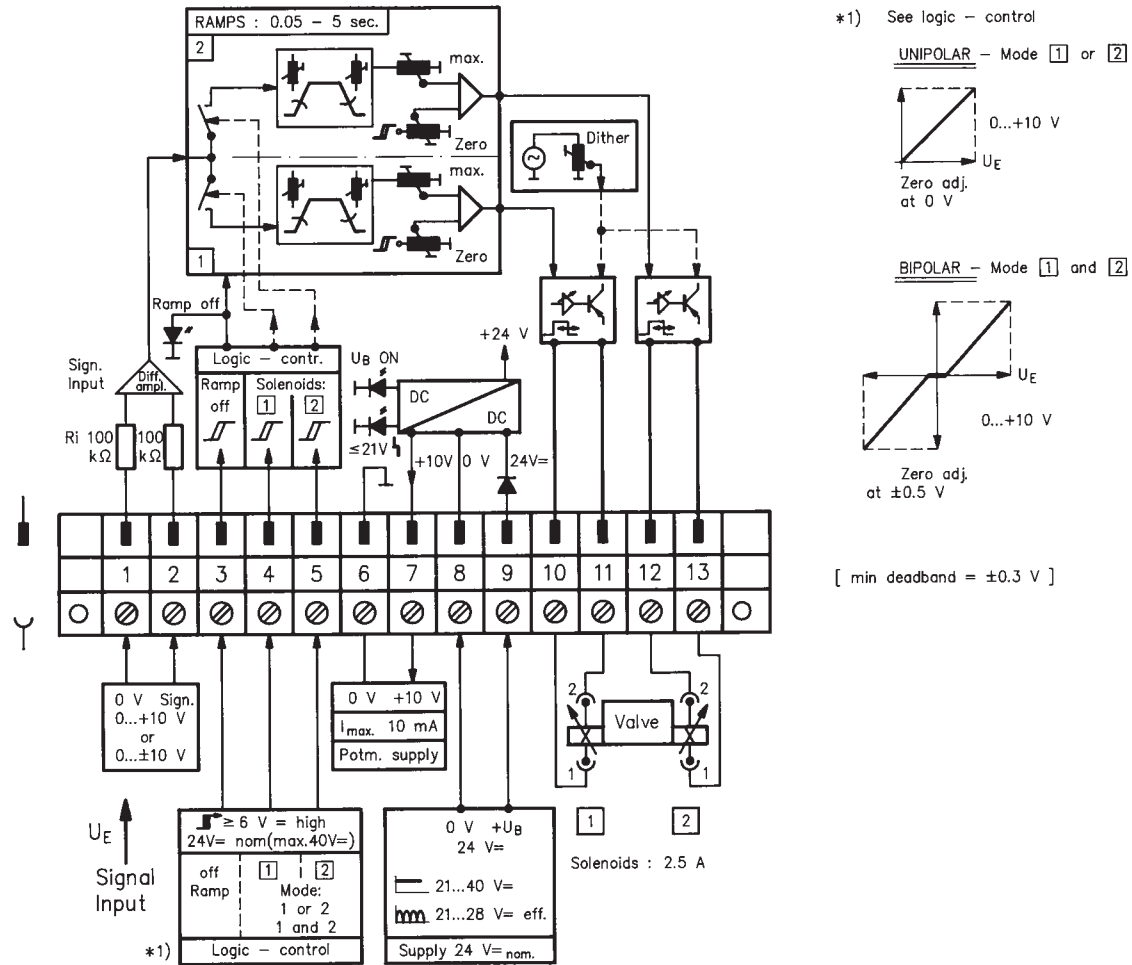

Front view/adjustment

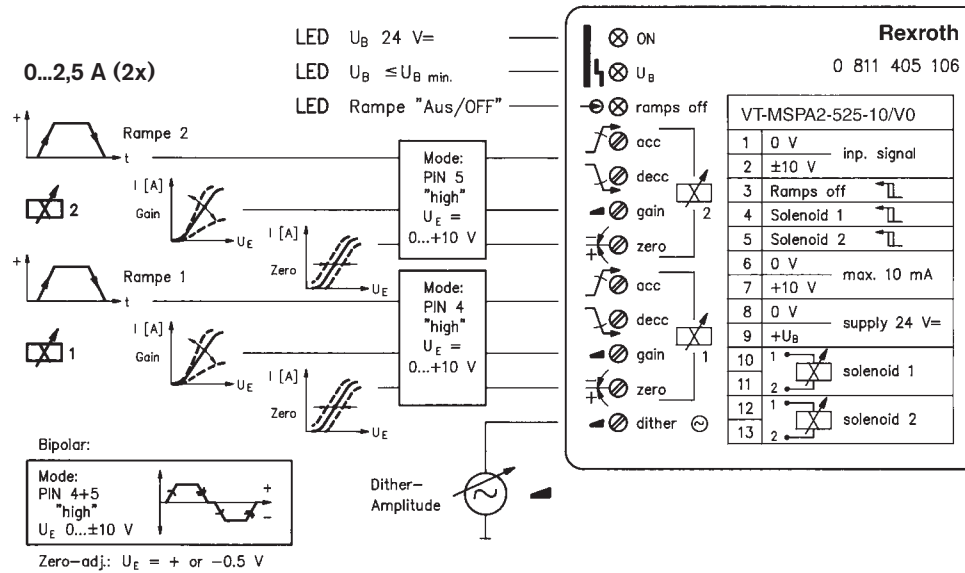

Characteristic curves NG6 (measured with HLP 46, $\vartheta_{oil} = 40^\circ\text{C} \pm 5^\circ\text{C}$)

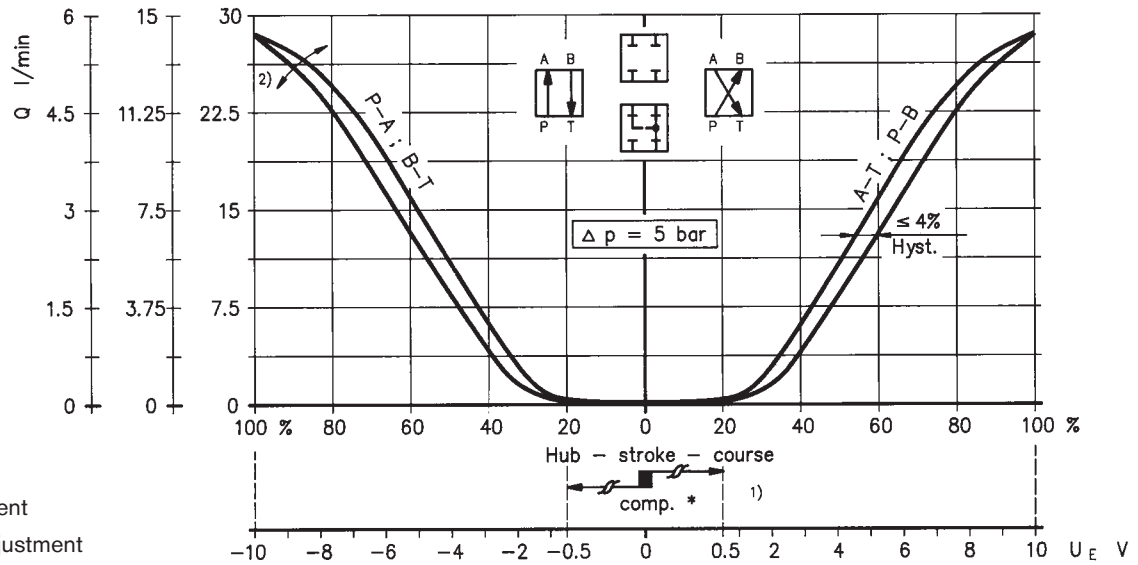

Valve amplifier

- 1) Zero adjustment
- 2) Sensitivity adjustment

Operating limits

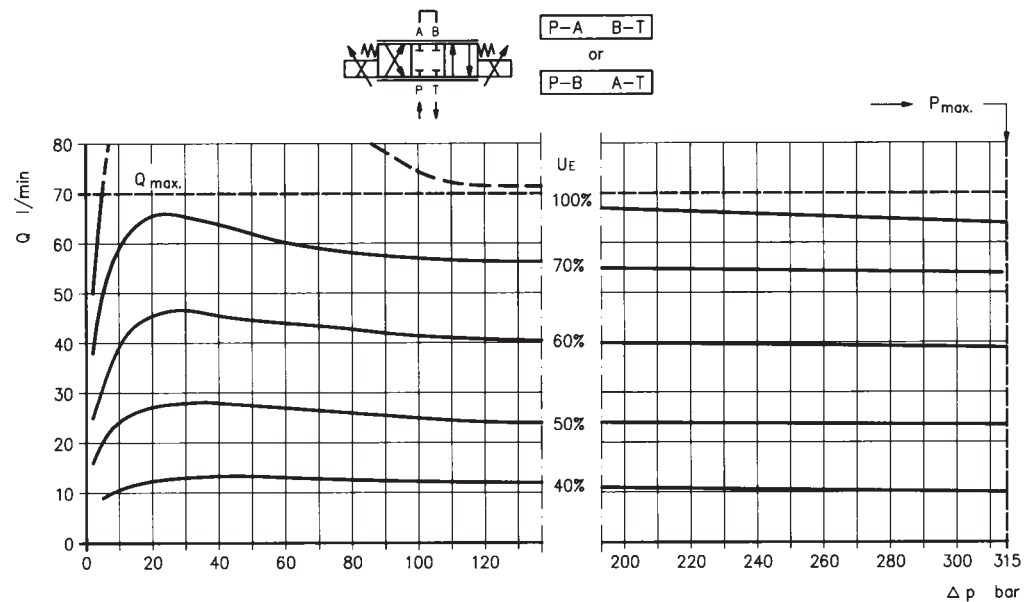
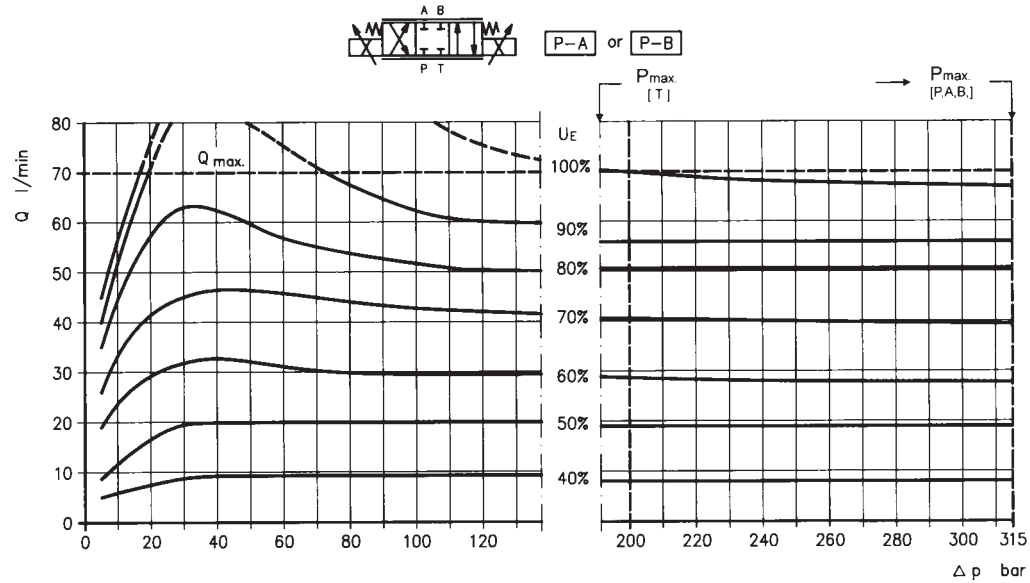

Characteristic curves NG10 (measured with HLP 46, $\vartheta_{oil} = 40^\circ\text{C} \pm 5^\circ\text{C}$)

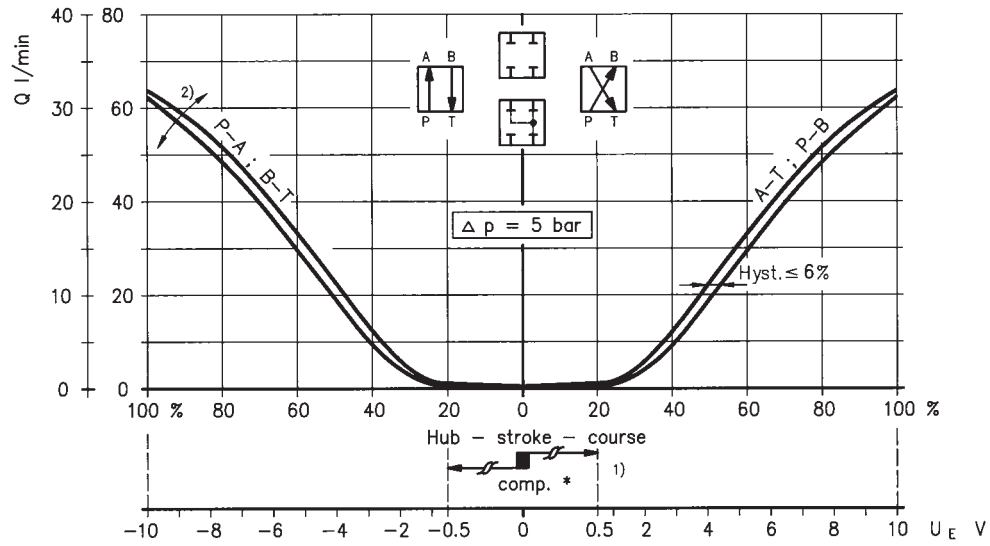

Valve amplifier

- 1) Zero adjustment
- 2) Sensitivity adjustment

Operating limits

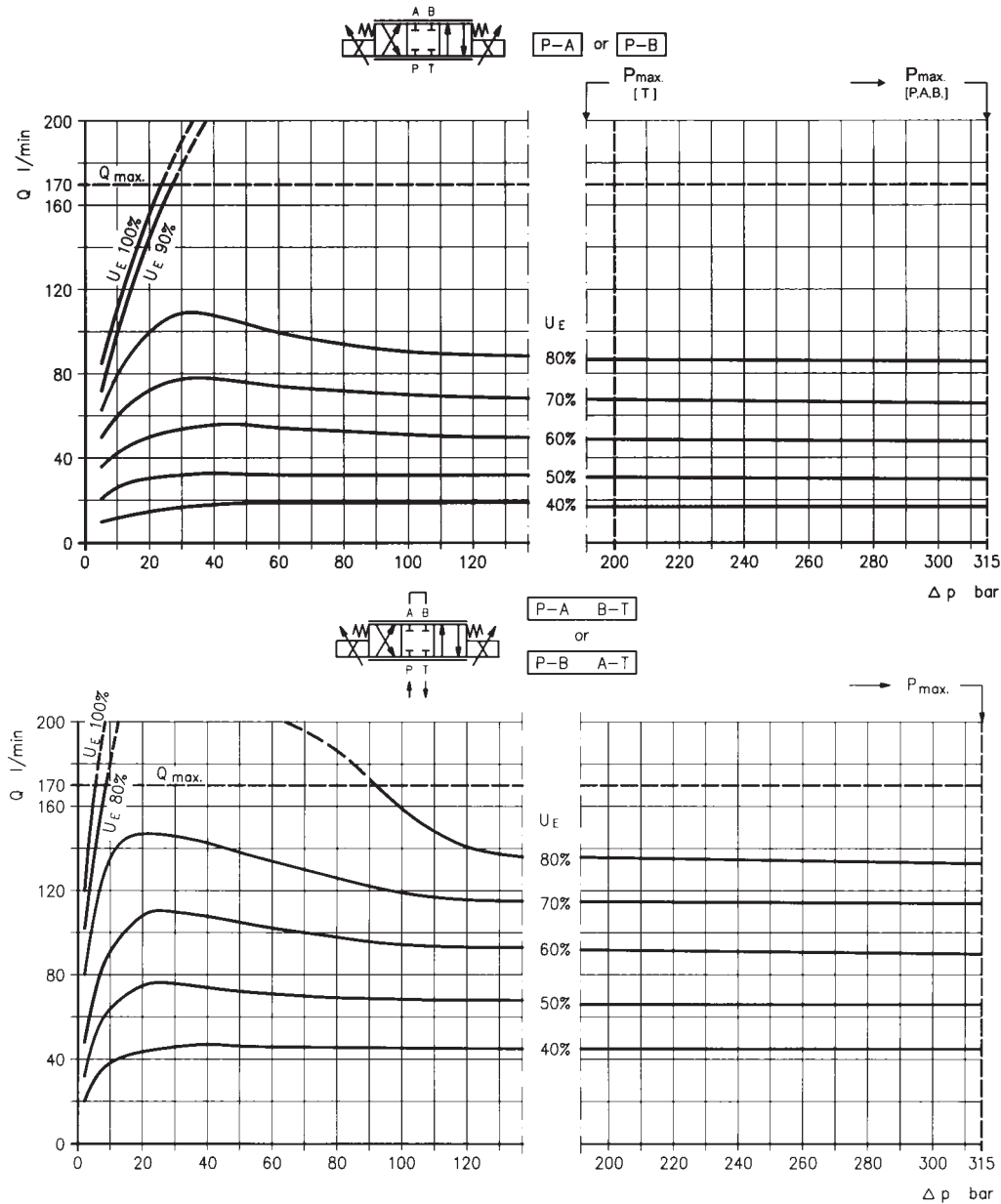

Unit dimensions NG10 (nominal dimensions in mm)

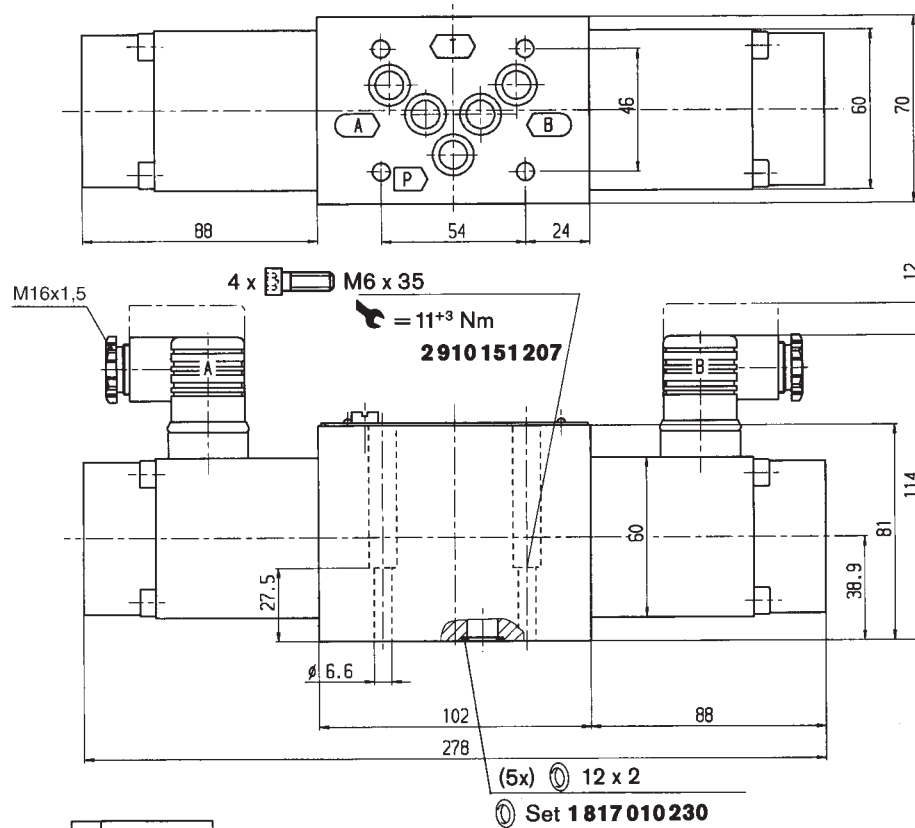

Required surface quality of mating component

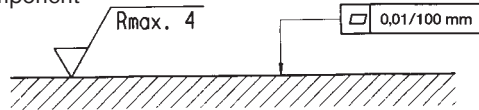

Mounting hole configuration: NG10 (ISO 4401-05-04-0-94)
For subplates, see catalog sheet RE 45055

- ¹⁾ Deviates from standard
- ²⁾ Thread depth:
Ferrous metal $1.5 \times \varnothing^*$
Non-ferrous $2 \times \varnothing$
- * NG10 min. 10.5 mm

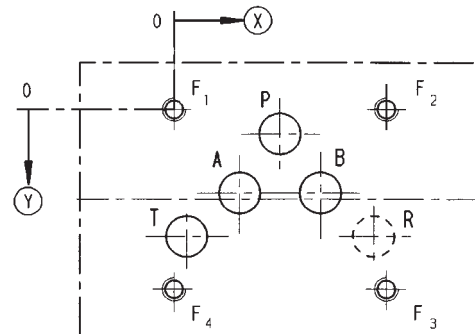

	P	A	T	B	F ₁	F ₂	F ₃	F ₄	R
⊗	27	16.7	3.2	37.3	0	54	54	0	50.8
⊙	6.3	21.4	32.5	21.4	0	0	46	46	32.5
∅	10.5 ¹⁾	10.5 ¹⁾	10.5 ¹⁾	10.5 ¹⁾	M6 ²⁾	M6 ²⁾	M6 ²⁾	M6 ²⁾	10.5 ¹⁾

Bosch Rexroth AG
Hydraulics
Zum Eisengießer 1
97816 Lohr am Main, Germany
Telefon +49 (0) 93 52 / 18-0
Telefax +49 (0) 93 52 / 18-23 58
documentation@boschrexroth.de
www.boschrexroth.de

© This document, as well as the data, specifications and other information set forth in it, are the exclusive property of Bosch Rexroth AG. It may not be reproduced or given to third parties without its consent. The data specified above only serve to describe the product. No statements concerning a certain condition or suitability for a certain application can be derived from our information. The information given does not release the user from the obligation of own judgement and verification. It must be remembered that our products are subject to a natural process of wear and aging.