



In- Line Filter



Description

The hydraulic in- line filter provides protection in hydraulic systems up to 350 bar. Fitted on the pressure side of a pump it will protect the system and its control valves down to 10 microns. The sintered bronze element will not collapse, should foreign matter accumulate and increase pressure drop across the element.

The unique construction features an anodized aluminium housing for light weight, and a conically shaped sintered bronze element positioned by a retaining spring to allow true, uninterrupted axial flow. The standard 10 micron bronze filter element can be easily cleaned or replaced.

Operating temperatures: 0°C to 100°C

Dimensions

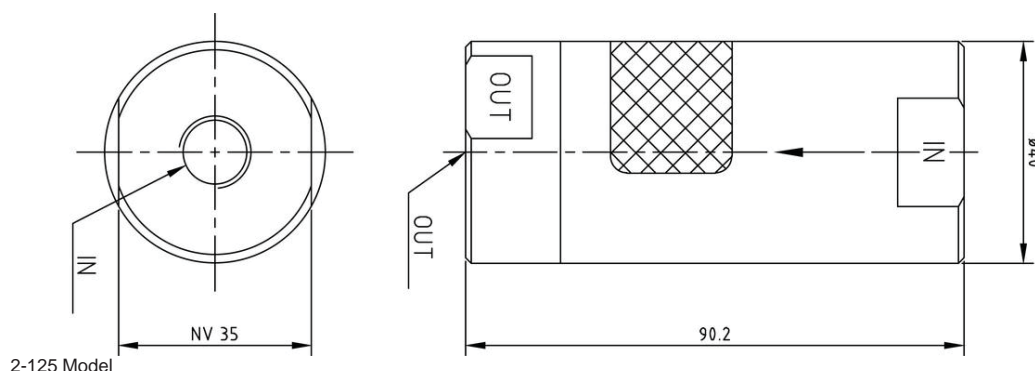

Function diagram

Ordering

Order no.	In / Out	Overall length	Dia.	Weight	Max. pressure	Element and seal
FIL-52-10	1/4" BSP	90.2 mm	40 mm	0.25 kg	350 bar	FIL- KIT-10
FIL-52-25	1/4" BSP	90.2 mm	40 mm	0.25 kg	350 bar	FIL- KIT-25
FIL-52-40	1/4" BSP	90.2 mm	40 mm	0.25 kg	350 bar	FIL- KIT-40
FIL-53-10	3/8" BSP	90.2 mm	40 mm	0.25 kg	350 bar	FIL- KIT-10
FIL-54-10	1/2" BSP	90.2 mm	40 mm	0.25 kg	350 bar	FIL- KIT-10
FIL- KIT-10	-	-	-	-	-	-

