

The Drive & Control Company

Rexroth
Bosch Group

Pressure relief valve,
pilot operated

Type DB...W65; DBW...W65; DB 20 K

RE 25818

Edition: 2012-07

Replaces: 08.03



H6964

- ▶ Size 10 and 25
- ▶ Component series 1X; 4X
- ▶ Maximum operating pressure 350 bar
- ▶ Maximum flow 400 l/min

Features

- ▶ For subplate mounting
- ▶ Porting pattern according to ISO 6264-06-09-*97 (size 10) and ISO 6264-08-13-*97 (size 25)
- ▶ For threaded connection
- ▶ As screw-in cartridge valve
- ▶ 4 adjustment types for pressure adjustment, optionally:
 - Rotary knob
 - Bushing with hexagon and protective cap
 - Lockable rotary knob with scale
 - Rotary knob with scale
- ▶ 5 pressure ratings
- ▶ Solenoid operated unloading via a built-on directional spool valve

Contents

Features	1
Ordering code	2, 3
Symbols	4
Function, section	5
Technical data	6, 7
Characteristic curves	7 ... 9
Unit dimensions	10 ... 15
Mounting cavity	14, 15
Unit dimensions	16
Mating connectors	19
General notes, More information	19
Type-examination tested safety valves type DB 20 K...E, component series 1X according to Pressure Equipment Directive 97/23/EC	
Ordering code	17
Deviating technical data	17
Safety instructions	18

RE 25818, edition: 2012-07, **Bosch Rexroth AG**

2/20 DB...W65; DBW...W65; DB 20 K | Pressure relief valve

Ordering code

01	02	03	04	05	06	07	08	09	10	11	12	13	14	15	16	17	18
DB					-	/											*

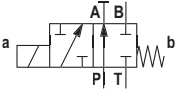
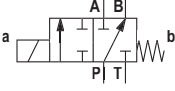
01	Pressure relief valve	DB
02	Without directional valve	no code
	With attached directional valve	W ¹⁾
03	- Size 10	
	Subplate mounting "-"	10
	Threaded connection "G" (G1 1/2)	10
	- Size 25	
	Subplate mounting "-"	20
	Threaded connection "G" (G3/4)	15
	Threaded connection "G" (G1)	20
Screw-in cartridge valve "K"	20	
04	 normally closed	A ²⁾
	 normally open	B ²⁾

Type of connection

05	Subplate mounting	-
	Threaded connection	G
	Screw-in cartridge valve	K

Adjustment type

06	Rotary knob	1
	Bushing with hexagon and protective cap	2
	Lockable rotary knob with scale	3 ³⁾
	Rotary knob with scale	7
07	Component series 10 to 19 (10 to 19: Unchanged installation and connection dimensions); (only version "K")	1X
	Component series 40 to 49 (40 to 49: Unchanged installation and connection dimensions); (only version "-" and "G")	4X

¹⁾ Only with version "G".

²⁾ Ordering code only necessary with version "W".

³⁾ H-key with the material no. **R900008158** is included in the scope of delivery.

⁴⁾ Dash "-" only necessary with version "W" and without specification of "U".

⁵⁾ Mating connectors, separate order, see page 19.

Notice!

In case spare parts of the screw-in cartridge valve for standard subplate mounting or threaded connection housing size 10 and 25 are necessary, **always** order type DB 20 K.-1X/.XY!

Type-examination tested safety valves are **only** available as type DB 20 K.-1X/.Y...E!

Preferred types and standard units are contained in the EPS (standard price list).

Bosch Rexroth AG, RE 25818, edition: 2012-07

Ordering code

01	02	03	04	05	06	07	08	09	10	11	12	13	14	15	16	17	18
DB						-	/										*

Pressure rating

08	Set pressure up to 50 bar	50
	Set pressure up to 100 bar	100
	Set pressure up to 200 bar	200
	Set pressure up to 315 bar	315
	Set pressure up to 350 bar (only version "DB")	350

Pilot oil supply and pilot oil return (see also Symbols on page 4)

09	Pilot oil supply and pilot oil return internal	- 4)
	Pilot oil supply external, pilot oil return internal	X
	Pilot oil supply internal, pilot oil return external	Y
	Pilot oil supply and pilot oil return external	XY

10	Standard version	no code
	Valve for minimum opening pressure (not suitable for mutual relief!)	U

11	Without directional valve	no code
	With directional spool valve (data sheet 23178)	6E 2)

12	Direct voltage 24 V	G24 2)
	AC voltage 230 V 50/60 Hz	W230 2)

13	With concealed manual override (standard)	N9 2)
	With manual override	N 2)
	Without manual override	no code

Electrical connection

14	Individual connection	
	Without mating connector with connector DIN EN 175301-803	K4 2)

Seal material

15	NBR seals	no code
	FKM seals	V
	(other seals upon request) Attention! Observe compatibility of seals with hydraulic fluid used!	

16	Vertical installation position of the screw-in cartridge valve (cartridge) (only version "-" and "G")	W65
	Any installation position of the screw-in cartridge valve (only version "K")	no code

Type examination

17	Without type examination	no code
	Safety valve according to Pressure Equipment Directive 97/23/EC	E

18	Further details in the plain text	
----	-----------------------------------	--

4/20 DB...W65; DBW...W65; DB 20 K | Pressure relief valve

Symbols

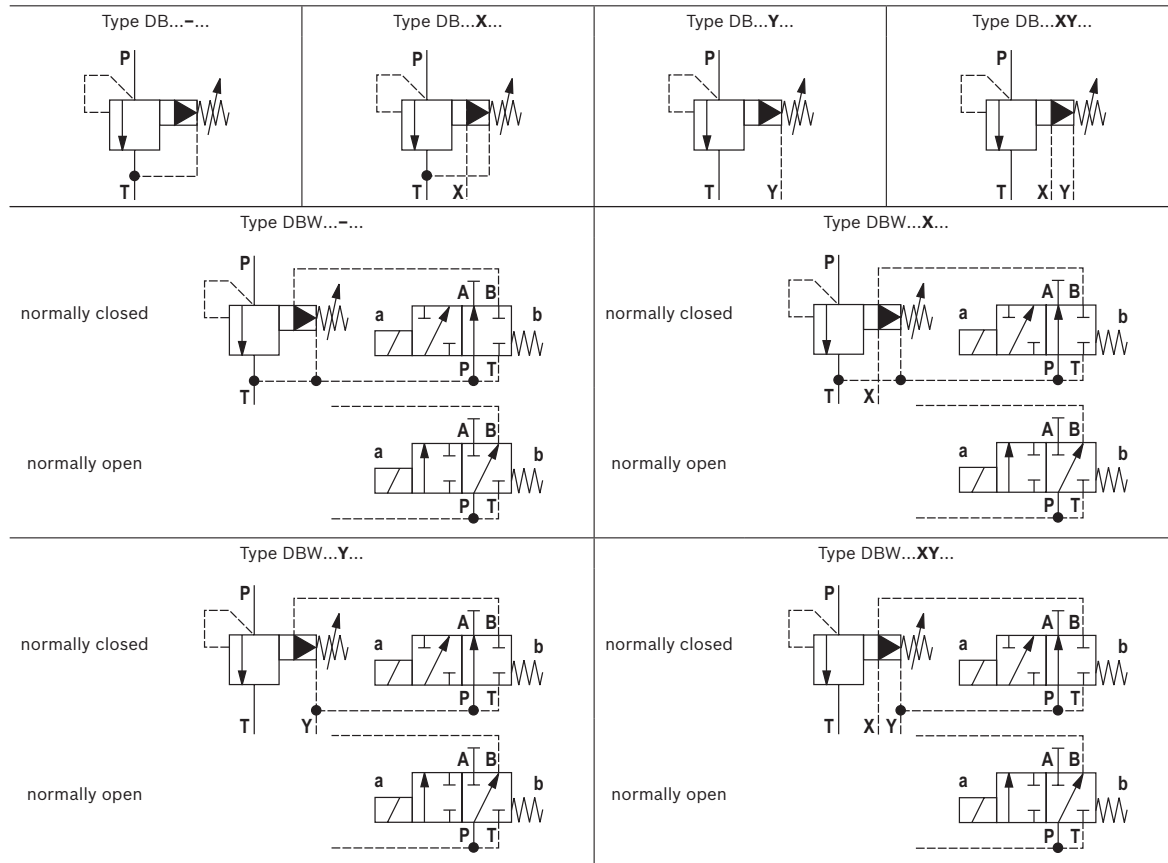

Bosch Rexroth AG, RE 25818, edition: 2012-07

Function, section

Valves of type DB and DBW are pilot operated pressure relief valves. They are used for limiting (DB) or limiting and magnetically unloading (DBW) the operating pressure. The valves basically consist of housing (1) and pilot control valve (2) with adjustment type.

Pressure relief valve type DB

The pressure applied to channel P acts on the main spool (3). Via the nozzle bores (4 and 5), the pressure is at the same time applied to the poppet (6). If the pressure in channel P exceeds the value set at spring (7), poppet (6) opens against spring (7). Via the nozzle bores (4 and 5), the hydraulic fluid from channel P now flows into the spring chamber (8). From here, it is led into the tank internally (version "-"), via the control line (9 and 10), or externally (version "Y") via the control line (9 and 11).

Due to the state of equilibrium at the main spool (3), hydraulic fluid flows from channel P to channel T, maintaining the set operating pressure.

A pressure gauge connection (12) allows for the control of the operating pressure.

The pressure relief valve can be unloaded or switched to another pressure (second pressure rating) via port X (13).

Pressure relief valve type DBW (only threaded connection)

The function of this valve is basically the same as that of valve type DB.

The main spool (3) is unloaded by controlling a built-on directional valve.

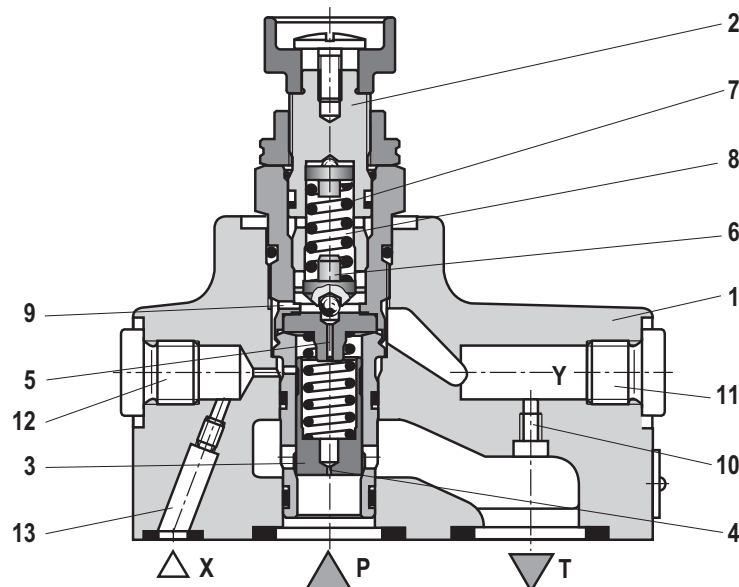

6/20 DB...W65; DBW...W65; DB 20 K | Pressure relief valve

Technical data

(For applications outside these parameters, please consult us!)

general					
Size			Size 10	Size 25	
Weight	▶ Subplate mounting "-"	kg	1.6	2.3	
	▶ Threaded connection "G"	- Type DB	kg	2.95	2.95
		- Type DBW	kg	4.25	4.25
	▶ Screw-in cartridge valve "K"	kg	-	0.35	
Installation position			Any		
Ambient temperature range	▶ Type DB	°C	-30 ... +80 (NBR seals) -15 ... +80 (FKM seals)		
			-30 ... +50 (NBR seals) -15 ... +50 (FKM seals)		
Minimum stability of the housing materials			Housing materials are to be selected so that there is sufficient safety for all imaginable operating conditions (e. g. with regard to compressive strength, thread stripping strengths and tightening torques).		

hydraulic				
Maximum operating pressure	▶ Port P, X	bar	350	
	▶ Port T	bar	315	
Maximum back pressure	▶ Port Y	bar	250	
	▶ Port Y, T	bar	210 (DC solenoid) 160 (AC solenoid)	
Minimum set pressure		bar	Flow-dependent, see characteristic curves page 8 ... 9	
Maximum set pressure		bar	50; 100; 200; 315; 350 (only type DB)	
Maximum flow	▶ Subplate mounting "-"	l/min	200	400
	▶ Threaded connection "G"		150	200 (G3/4); 300 (G1)
Hydraulic fluid			See table page 7	
Hydraulic fluid temperature range (at the valve's working ports)		°C	-20 ... +80 (NBR seals) -15 ... +80 (FKM seals) -20 ... +50 (HFC hydraulic fluid)	
Viscosity range		mm ² /s	10 ... 800	
Maximum permitted degree of contamination of the hydraulic fluid - cleanliness class according to ISO 4406 (c)			Class 20/18/15 ¹⁾	

¹⁾ The cleanliness classes specified for the components must be adhered to in hydraulic systems. Effective filtration prevents faults and at the same time increases the service life of the components.
For the selection of the filters see www.boschrexroth.com/filter.

Technical data for directional spool valve see data sheet 23178.

Technical data

(For applications outside these parameters, please consult us!)

hydraulic			
Hydraulic fluid	Classification	Suitable sealing materials	Standards
Mineral oils	HL, HLP, HLPD, HVLP, HVLPD	NBR, FKM	DIN 51524
Bio-degradable	- Insoluble in water	HETG	VDMA 24568
		HEES	
	- Soluble in water	HEPG	VDMA 24568

 **Important information on hydraulic fluids!**

- ▶ For more information and data on the use of other hydraulic fluids refer to data sheet 90220 or contact us!
- ▶ There may be limitations regarding the technical valve data (temperature, pressure range, service life, maintenance intervals, etc.)!
- ▶ The flash point of the hydraulic fluid used must be 40 K higher than the maximum solenoid surface temperature.

▶ **Environmentally compatible:** When using environmentally compatible hydraulic fluids that are simultaneously zinc-solving, zinc may accumulate (700 mg zinc per pole tube).

Characteristic curves

(measured with HLP46, $\vartheta_{oil} = 40 \pm 5 \text{ }^\circ\text{C}$)

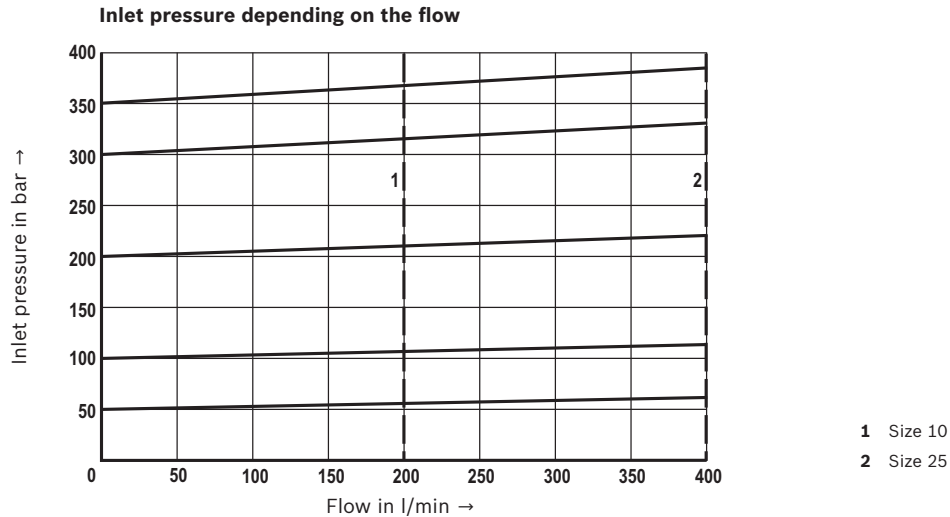

Notice!

The characteristic curves were measured with **external, depressurized pilot oil return**.

With internal pilot oil return, the inlet pressure increases by the output pressure present in port T.

8/20 DB...W65; DBW...W65; DB 20 K | Pressure relief valve

Characteristic curves: Subplate mounting
(measured with HLP46, $\vartheta_{oil} = 40 \pm 5 \text{ }^\circ\text{C}$)

Minimum set pressure and circulation pressure depending on the flow ¹⁾
Standard version

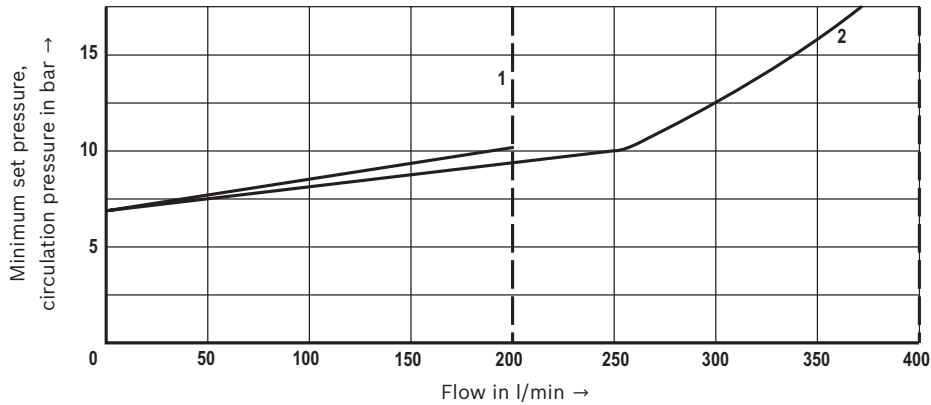

- 1 Size 10
- 2 Size 25

Minimum set pressure and circulation pressure depending on the flow ¹⁾
Version "U"

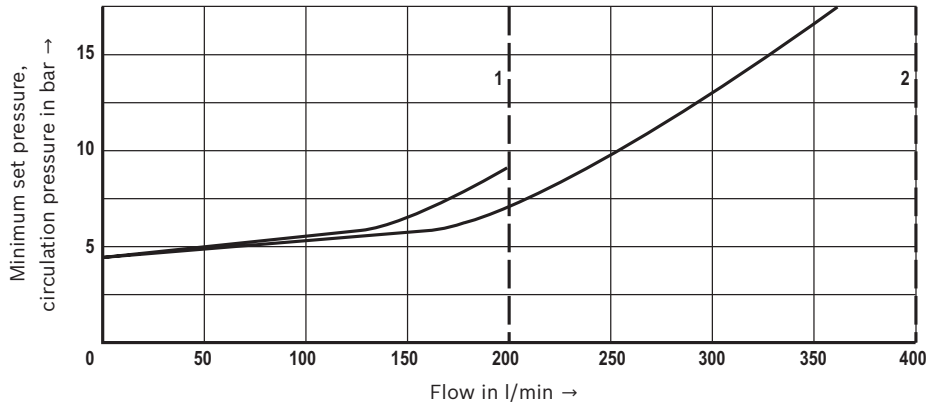

- 1 Size 10
- 2 Size 25

Notice!

The characteristic curves were measured with **external, depressurized pilot oil return**.
With internal pilot oil return, the inlet pressure increases by the output pressure present in port T.

¹⁾ The characteristic curves apply to the pressure at the valve output $p_T = 0$ bar across the entire flow range.

Characteristic curves: Threaded connection
(measured with HLP46, $\vartheta_{oil} = 40 \pm 5 \text{ }^\circ\text{C}$)

Minimum set pressure and circulation pressure depending on the flow ¹⁾
Standard version

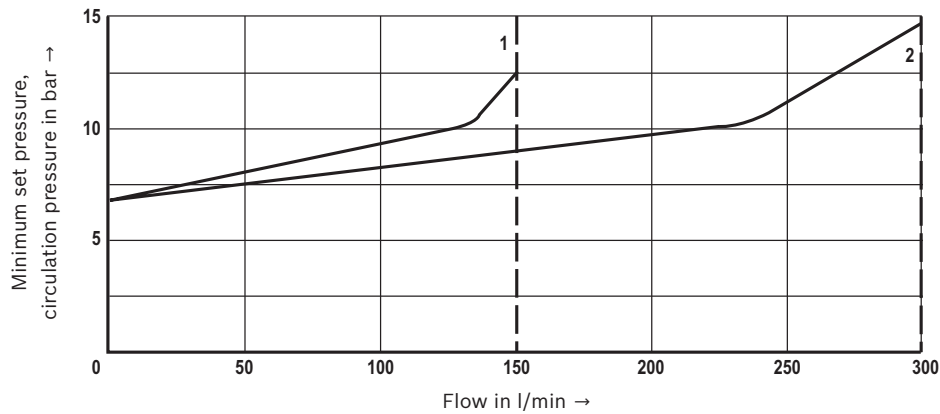

- 1 Size 10
- 2 Size 25

Minimum set pressure and circulation pressure depending on the flow ¹⁾
Version "U"

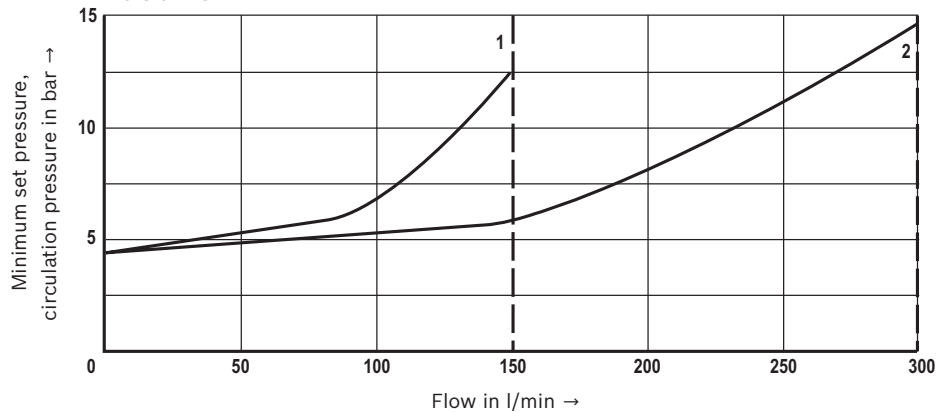

- 1 Size 10
- 2 Size 25

Notice!

The characteristic curves were measured with **external, depressurized pilot oil return.**

With internal pilot oil return, the inlet pressure increases by the output pressure present in port T.

¹⁾ The characteristic curves apply to the pressure at the valve output $p_T = 0 \text{ bar}$ across the entire flow range.

10/20 DB...W65; DBW...W65; DB 20 K | Pressure relief valve

Unit dimensions: Subplate mounting – size 10
(dimensions in mm)

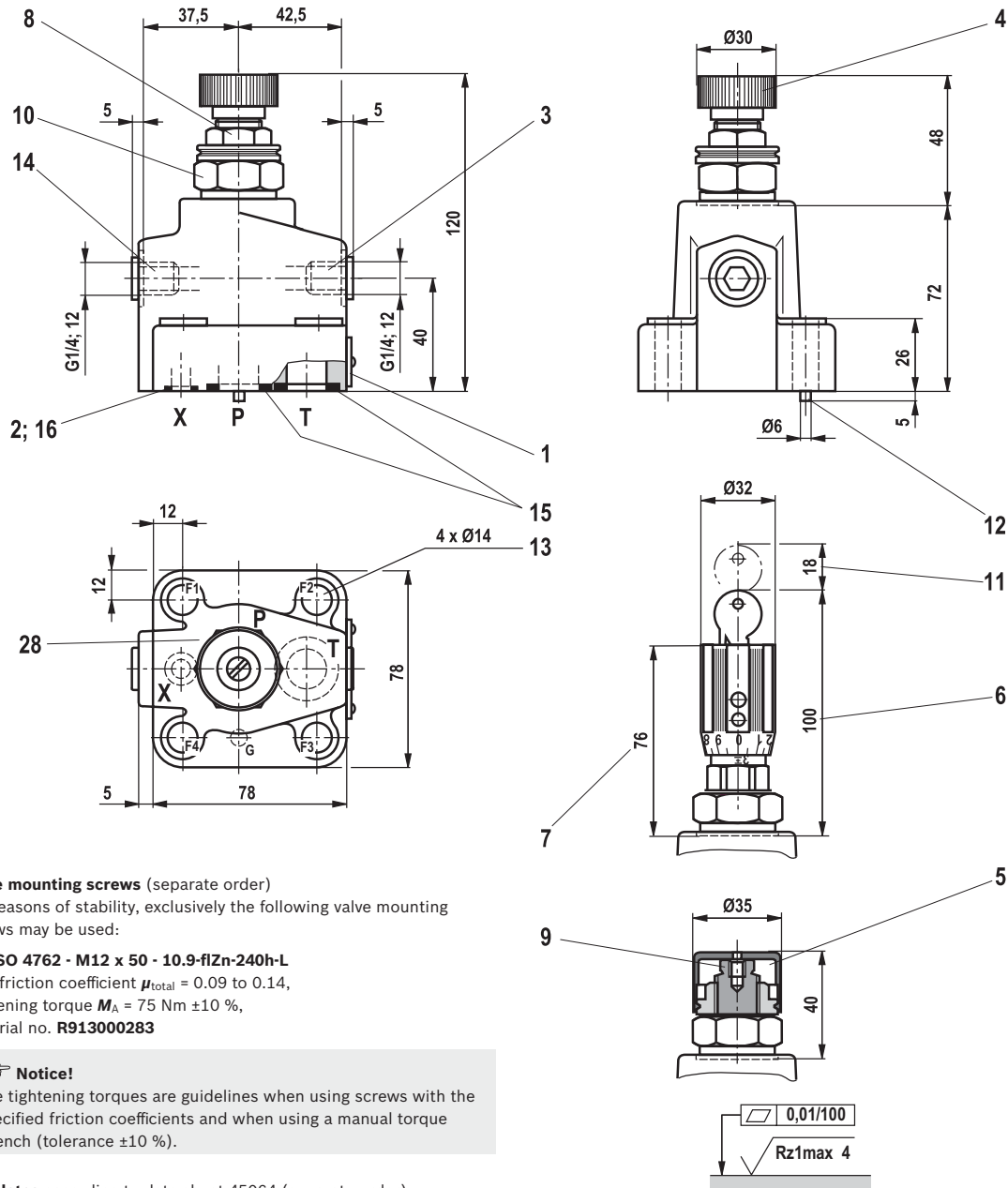

Valve mounting screws (separate order)

For reasons of stability, exclusively the following valve mounting screws may be used:

4 x ISO 4762 - M12 x 50 - 10.9-fIZn-240h-L
with friction coefficient $\mu_{total} = 0.09$ to 0.14 ,
tightening torque $M_A = 75$ Nm ± 10 %,
material no. **R913000283**

Notice!

The tightening torques are guidelines when using screws with the specified friction coefficients and when using a manual torque wrench (tolerance ± 10 %).

Subplates according to data sheet 45064 (separate order)

G 545/01 (G3/8)
G 546/01 (G1/2)
G 565/01 (G3/4)

Required surface quality of the valve mounting face

Item explanations see page 16.

Bosch Rexroth AG, RE 25818, edition: 2012-07

Unit dimensions: Subplate mounting – size 25
(dimensions in mm)

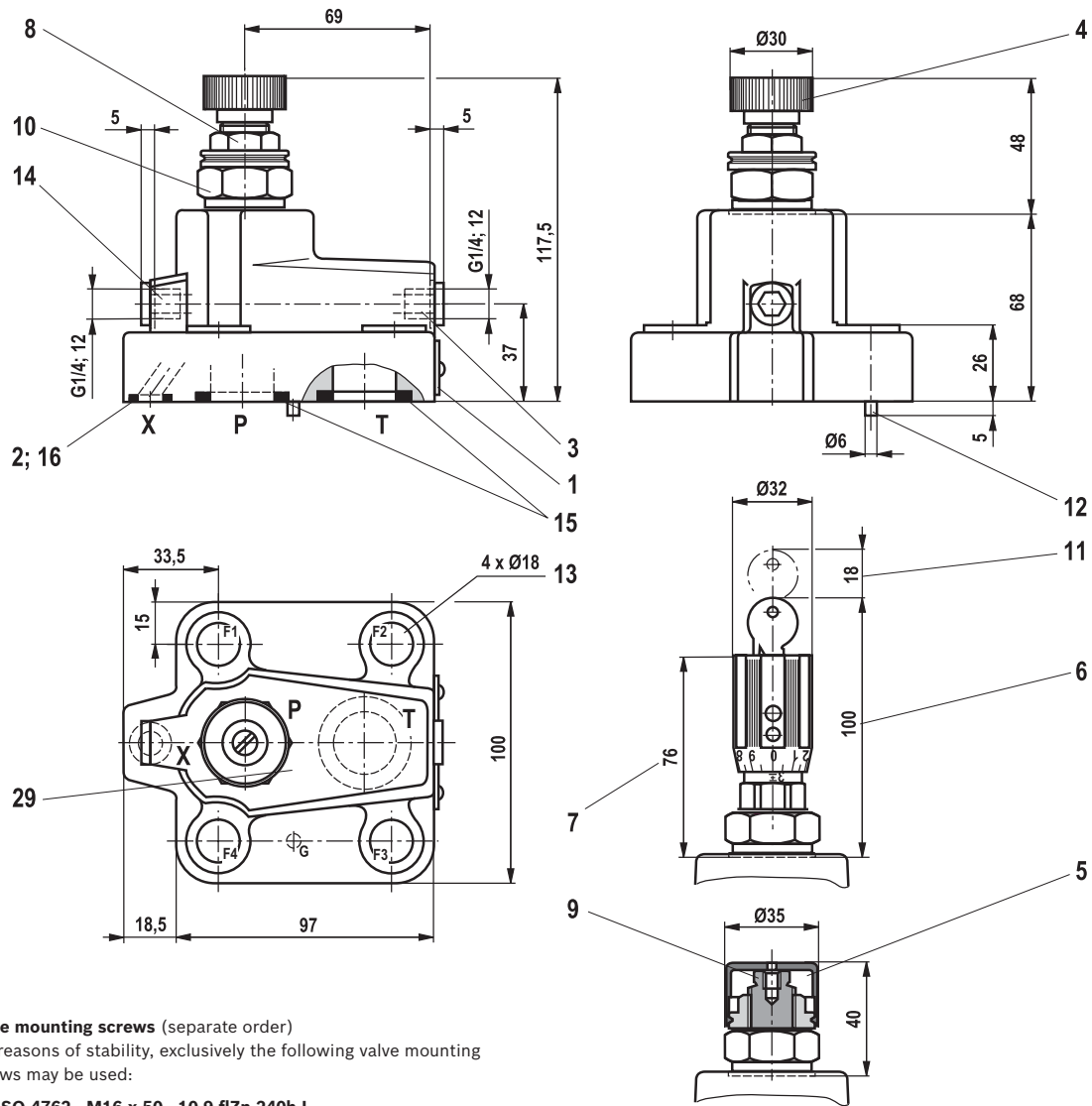

Valve mounting screws (separate order)

For reasons of stability, exclusively the following valve mounting screws may be used:

4 x ISO 4762 - M16 x 50 - 10.9-flZn-240h-L
with friction coefficient $\mu_{\text{total}} = 0.09$ to 0.14 ,
tightening torque $M_A = 185 \text{ Nm} \pm 10 \%$,
material no. **R913000378**

Notice!

The tightening torques are guidelines when using screws with the specified friction coefficients and when using a manual torque wrench (tolerance $\pm 10 \%$).

Subplates according to data sheet 45064 (separate order)

G 408/01 (G3/4)

G 409/01 (G1)

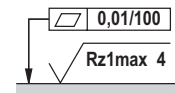

Required surface quality of the valve mounting face

Item explanations see page 16.

12/20 DB...W65; DBW...W65; DB 20 K | Pressure relief valve

Unit dimensions: Threaded connection
(dimensions in mm)

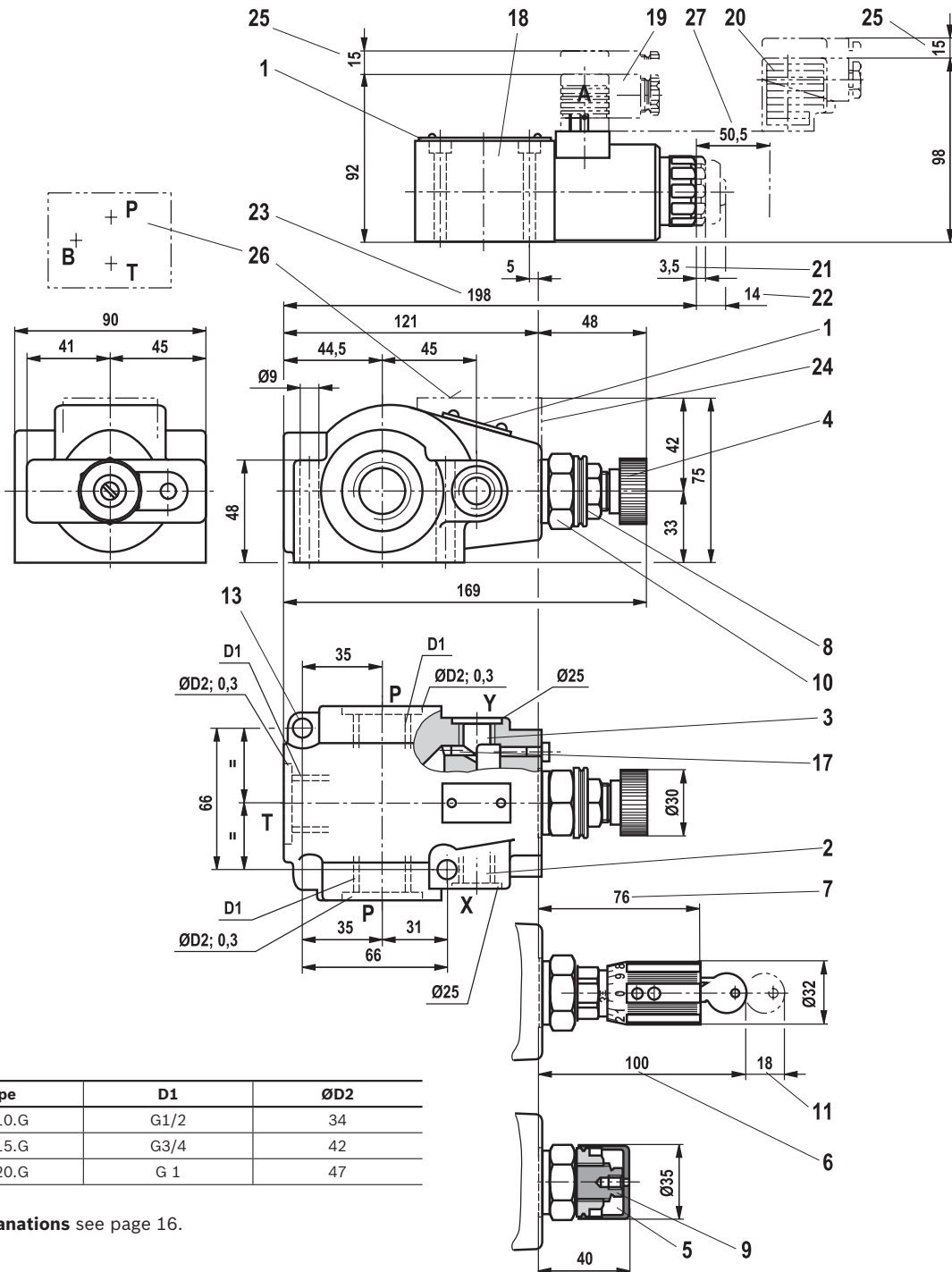

Type	D1	ØD2
DB.10.G	G1/2	34
DB.15.G	G3/4	42
DB.20.G	G 1	47

Item explanations see page 16.

Bosch Rexroth AG, RE 25818, edition: 2012-07

Unit dimensions: Screw-in cartridge valve
(dimensions in mm)

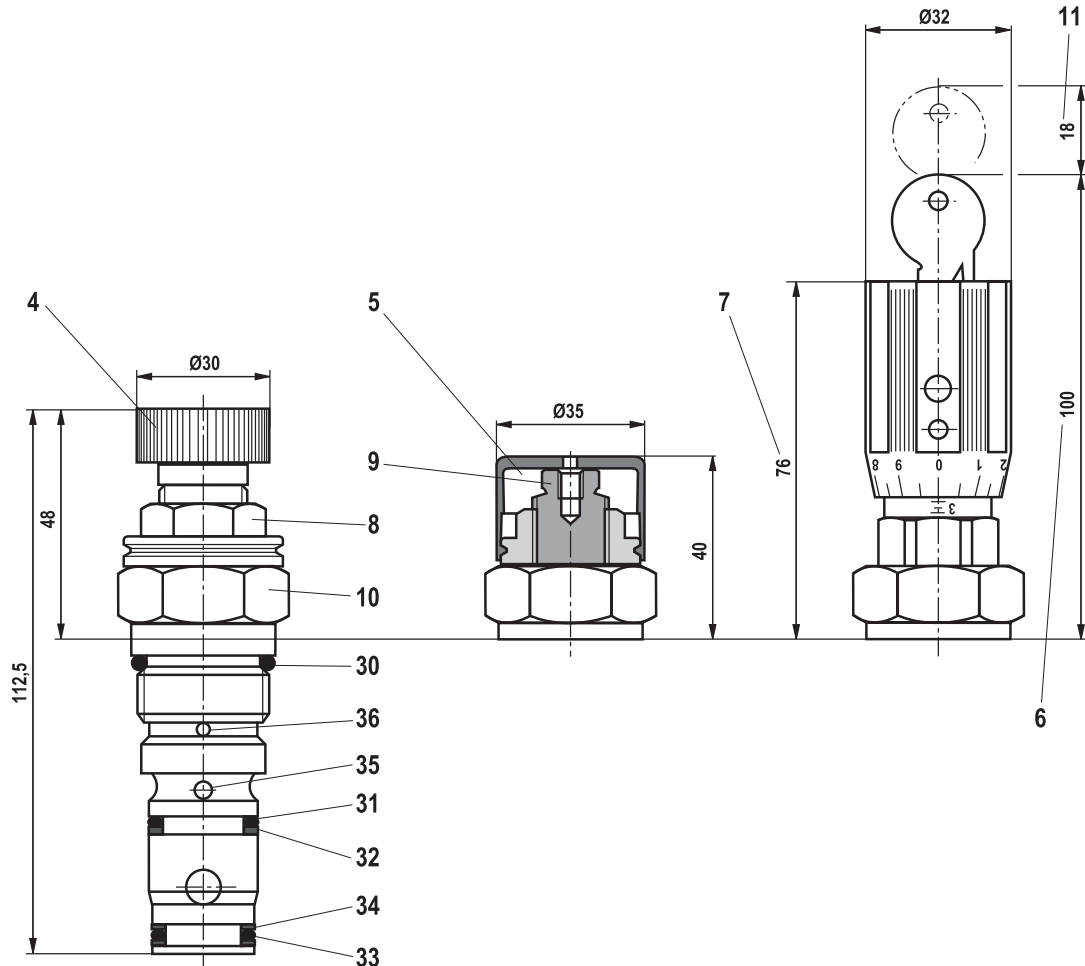

Item explanations see page 16.

14/20 DB...W65; DBW...W65; DB 20 K | Pressure relief valve

Mounting cavity: Version "XY" and type-examination tested safety valves version "Y...E"
(dimensions in mm)

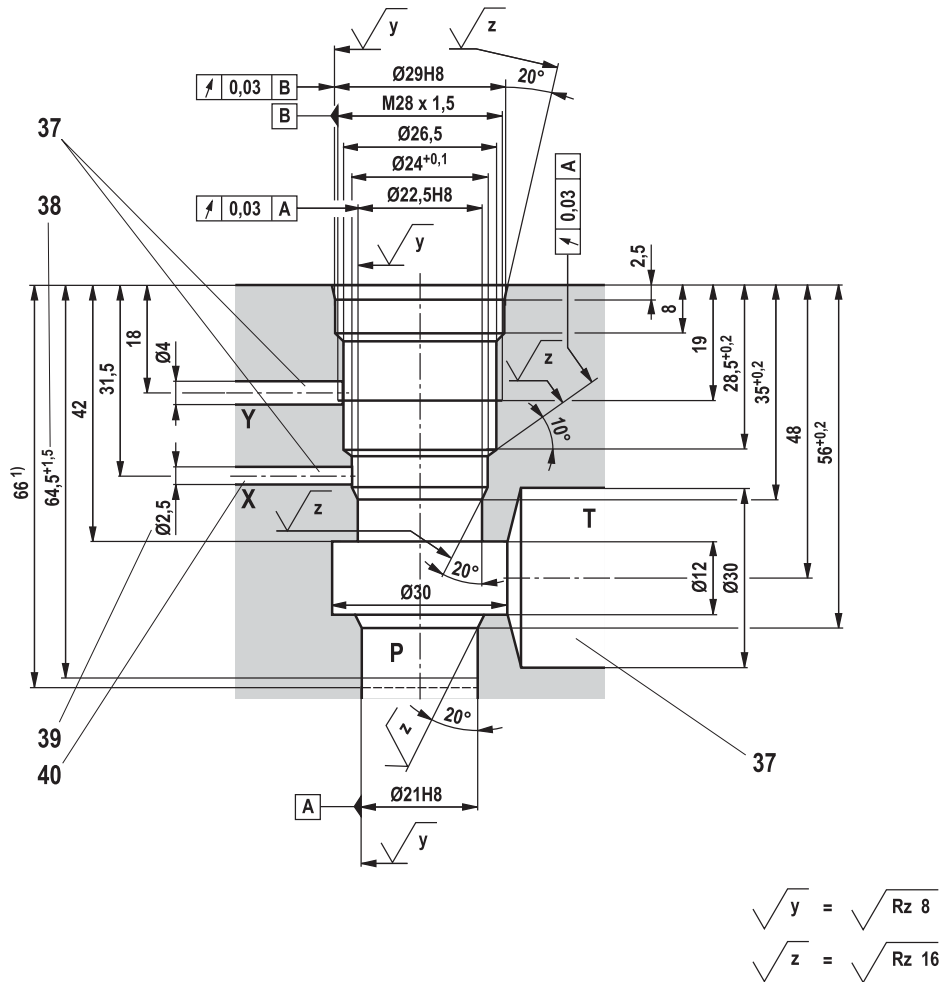

¹⁾ Installation depth

Item explanations see page 16.

Mounting cavity: Version "Y"
 (dimensions in mm)

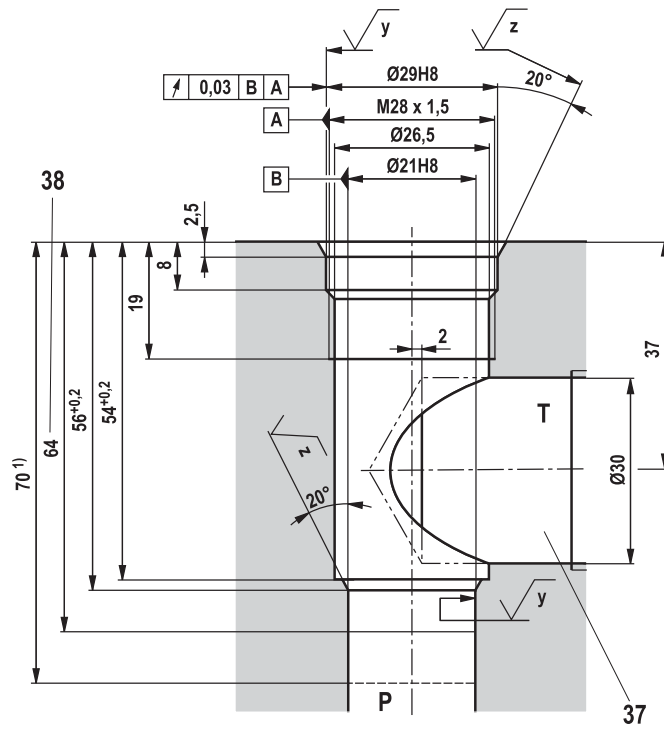

¹⁾ Installation depth

Item explanations see page 16.

16/20 DB...W65; DBW...W65; DB 20 K | Pressure relief valve

Unit dimensions

- 1 Name plate
- 2 Port X for remote control, optional
- 3 Y port for pilot oil return, external
- 4 Adjustment type "1"
- 5 Adjustment type "2"
- 6 Adjustment type "3"
- 7 Adjustment type "7"
- 8 Lock nut SW22, tightening torque $M_A = 10^{+5}$ Nm
- 9 Hexagon SW10
- 10 Hexagon SW30, tightening torque $M_A = 50$ Nm
- 11 Space required to remove the key
- 12 Locating pin
- 13 Valve mounting bores
- 14 Pressure gauge connection
- 15 Identical seal rings for ports P and T
- 16 Seal ring for port X
- 17 Setscrew is omitted with internal pilot oil return
- 18 Directional spool valve size 6, see data sheet 23178
- 19 Mating connector **without** circuitry
(separate order, see page 19)
- 20 Mating connector **with** circuitry
(separate order, see page 19)
- 21 Dimension for valve without manual override
- 22 Dimension for valve with manual override "N"
- 23 Dimension for valve with concealed manual override "N9"
- 24 Housing for version "W"
- 25 Space required to remove the mating connector
- 26 Valve contact surface; port A is not bored
- 27 Space required to remove the solenoid coil
- 28 Porting pattern according to ISO 6264-06-09-*-*97
- 29 Porting pattern according to ISO 6264-08-13-*-*97
- 30 Seal ring
- 31 Seal ring (omitted with version "Y")
- 32 Support ring (omitted with version "Y")
- 33 Seal ring
- 34 2 support rings
- 35 Bore for port X not available with version "Y"
- 36 Bore for port Y available with version "XY" and "Y"
- 37 ► Bore X, Y and T optionally at the circumference for version "XY"
► Bore B optionally at the circumference for version "Y"
- 38 Depth of fit
- 39 Bore $\varnothing 2.5$ is only to be bored if necessary
- 40 Port X does not have to be bored for type-examination tested safety valves version "Y...E" as it does not have any function!

Bosch Rexroth AG, RE 25818, edition: 2012-07

Pressure relief valve | **DB...W65; DBW...W65; DB 20 K** 17/20

Ordering code: Type-examination tested safety valves type DB 20 K...E, component series 1X according to Pressure Equipment Directive 97/23/EC

Size	Type designation	Part marking	Maximum flow q_{Vmax} in l/min	Set response overpressure p in bar
25	DB 20 K <input type="checkbox"/> ¹ -1X/ <input type="checkbox"/> ² Y <input type="checkbox"/> ³ E	TÜV.SV. <input type="checkbox"/> -1001.14,4.F.G.p	70	30 ... 60
			100	61 ... 110
			150	111 ... 210
			200	211 ... 315
			300	316 ... 350

Adjustment type

1	Hand wheel (Pressure setting sealed, unloading or setting of a lower response pressure possible!)	1
	With sealed protective cap (no adjustment/unloading possible)	2
2	Pressure in the designation is to be entered by the customer, pressure setting ≥ 30 bar and possible in 5-bar steps.	e. g. 150
3	NBR seals	no code
	FKM seals	V
	Value entered ex factory	1X

Deviating technical data: Type-examination tested safety valves type DB 20 K...E, component series 1X according to Pressure Equipment Directive 97/23/EC ¹⁾

hydraulic			
Maximum back pressure	- Port Y	bar	0
	- Port T	"No code" version "Y" version	bar 10
Maximum flow			See preceding table
Hydraulic fluid			Mineral oil (HL, HLP) according to DIN 51524
Hydraulic fluid temperature range		°C	-20 ... +60 (NBR seals) -15 ... +60 (FKM seals)
Viscosity range		mm ² /s	12 ... 230

¹⁾ For applications outside these parameters, please consult us!

18/20 DB...W65; DBW...W65; DB 20 K | Pressure relief valve

Safety instructions: Type-examination tested safety valves type DB 20 K...E, component series 1X according to Pressure Equipment Directive 97/23/EC

- ▶ Before ordering a type-examination tested safety valve, please observe that at the desired **response pressure p** , the maximum admissible **flow $q_{V \max}$** (= numerical value at the position of letter "G" in the part identification) of the safety valve is higher than the maximum possible flow of the system/accumulator to be secured. In this, the corresponding regulations have to be observed!
- ▶ According to the **Pressure Equipment Directive 97/23/EC**, the increase in system pressure caused by the flow must not exceed 10 % of the set response pressure (see part identification).
- ▶ The maximum admissible flow $q_{V \max}$ specified in the part identification must not be exceeded.
- ▶ Discharge lines of safety valves must end in a non-dangerous manner. The accumulation of fluids in the discharge lines must **not** be possible (see AD2000 - data sheet A2).



It is imperative to observe the application notes!

- ▶ In the plant, the response pressure specified in the part identification is set with a flow of 2 l/min.
- ▶ The maximum admissible flow specified in the part identification applies to:
 - External pilot oil return **"Y"** without back pressure in the pilot oil return line:
Admissible back pressure in the discharge line (port T) < 10 bar.
- ▶ By removing a lead seal at the safety valve, the approval according to the Pressure Equipment Directive becomes void
- ▶ Mounting cavities (see page 14 and 15)
- ▶ Basically, the requirements of the pressure equipment directives and of data sheet AD2000 A2 have to be observed!

Bosch Rexroth AG, RE 25818, edition: 2012-07

Mating connectors according to DIN EN 175301-803

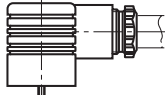
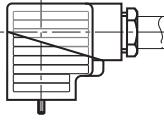
For details and more mating connectors see data sheet 08006				
		Material no.		
Color	Without circuitry	With indicator light 12 ... 240 V	With rectifier 12 ... 240 V	With indicator light and Zener diode suppression circuit 24 V
Gray	R901017010	-	-	-
Black	R901017011	R901017022	R901017025	R901017026

General notes

- ▶ The unloading function (directional valve function with version "W") must not be used for safety functions!
- ▶ With version "B", the lowest adjustable pressure (circulation pressure) is set in case of power failure or cable break. With version "A", the pressure relief function is set in case of power failure or cable break.
- ▶ Hydraulic backpressures in port T with internal pilot oil return and/or port Y with external pilot oil return add 1:1 to the response pressure of the valve set at the pilot control.

Example:

Pressure setting of the valve due to spring pretensioning (item 7 on page 5) in the pilot control valve/adjustment type $p_{\text{spring}} = 200 \text{ bar}$

Hydraulic backpressure in port T with internal pilot oil return $p_{\text{hydraulic}} = 50 \text{ bar}$

=> Response pressure = $p_{\text{spring}} + p_{\text{hydraulic}} = 250 \text{ bar}$

More information

- ▶ Directional spool valve
- ▶ Subplates
- ▶ Hydraulic fluids on mineral oil basis
- ▶ General product information on hydraulic products
- ▶ Assembly, commissioning and maintenance of industrial valves
- ▶ Selection of the filters

Data sheet 23178

Data sheet 45064

Data sheet 90220

Data sheet 07008

Data sheet 07003

www.boschrexroth.com/filter

20/20 DB...W65; DBW...W65; DB 20 K | Pressure relief valve

Notes

© This document, as well as the data, specifications and other information set forth in it, are the exclusive property of Bosch Rexroth AG. It may not be reproduced or given to third parties without its consent.
The data specified above only serve to describe the product. No statements concerning a certain condition or suitability for a certain application can be derived from our information. The information given does not release the user from the obligation of own judgment and verification. It must be remembered that our products are subject to a natural process of wear and aging.

Bosch Rexroth AG, RE 25818, edition: 2012-07