

PS-Series, PocketShear®

ENERPAC
POWERFUL SOLUTIONS. GLOBAL FORCE.

▼ Shown: PSH05-O and PSB05-TH



- Available in battery or hydraulic versions and sizes to cut .5 inch or .6 inch strand sizes
- Reversible, hardened blades extend life and provide over 2,000 cuts
- Shear tendons inside the pocket, providing controlled tendon length without applying heat to the anchorage
- Battery models include two industrial 28 VDC battery packs and fast charger
- Battery models shipped in durable product case for protection and easy transport
- Eliminates the need for Hot Work Permits on the job when cutting tendon tails
- Provides quick and effortless tendon cutting with no risk of abrasive saw kick-back



◀ The hydraulic PocketShear® makes quick and easy work of shearing tails on this elevated slab.

Cut PT Tendons in the Pocket with Hydraulic or Battery Power



Shear Pump

To power the hydraulic version, the Enerpac ZUPS-0208SB Shear Pump is the perfect choice.



Replacement Blades

Order the correct blades to match your Shear from the table shown below.

For PocketShear® Blade

Power Type	Blade Type	Strand Diameter (in)	Order Model No.
Hydraulic	Fixed	.5	PSBF-05H
	Fixed	.6	PSBF-06H
	Rotating	.5	PSBR-05H
	Rotating	.6	PSBR-06H
Battery	Fixed	.6	PSBF-05B
	Fixed	.5	PSBF-06B
	Rotating	.6	PSBR-05B
	Rotating	.5	PSBR-06B



Additional Protection

After shearing the tendon, the PocketCap® is the perfect way to seal the pocket and reduce the chance for corrosion in the anchorage zone.

Hydraulic and Battery Powered Shears



Only the PocketShear® can guarantee adequate concrete cover, no heating of the tendon or wedge set, and a clean cut end.



Cut-off saws cannot cut the tendon inside the pocket, leaving the tendon end exposed to moisture, creating the chance for corrosion.



Oxyacetylene torches heat the tendon and the wedge when cut deep inside the pocket.



Even if the tendon is cut at the correct depth, the tendon is still heated and the end is left jagged, preventing re-gripping for possible future lift-off.



Without controls, there is little chance for correct coverage of the tendon, leading to future corrosion.

PS Series



Strand Capacity:
0.5-0.6 inch

Powered:
Hydraulic and Battery

Maximum Operating Pressure:
3,000 psi



Open Throat Design

The Hydraulic PocketShear® features an Open-Throat design that allows easy insertion of the strand into the tool. This makes the Shear easier to position and operate on elevated applications.

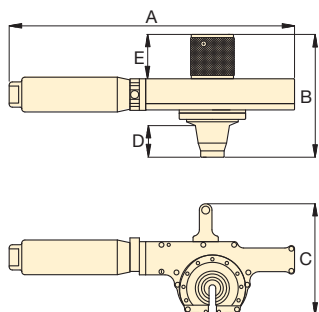

Hydraulic Version

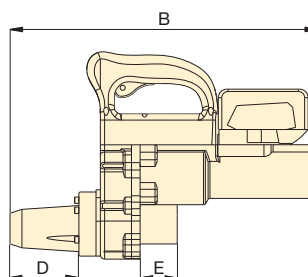
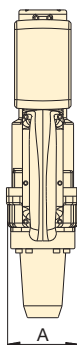

Battery Version

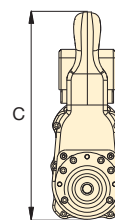

▼ SELECTION CHART*

Strand Diameter	Power Type	Model Number	Throat Style ¹⁾	Operating Pressure	Length	Depth	Height	Nose Depth	Clamp Depth	Weight
(in)				(psi)	A (in)	B (in)	C (in)	D (in)	E (in)	(lbs)
0.5	Battery	PSB05-TH	Through	n/a	4.25	17.99	12.12	4.03	2.17	29.1
0.6	Battery	PSB06-TH	Through	n/a	5.75	18.10	13.50	4.13	2.13	37.7
0.5	Hydraulic	PSH05-O	Open	3000	22.60	9.80	8.80	2.51	3.50	27
0.6	Hydraulic	PSH06-O	Open	3000	28.60	10.70	10.20	3.02	3.50	35

¹⁾ May be special ordered with other throat styles, consult with Enerpac.
* Values subject to change.