

Electric Drives
and Controls

Hydraulics

Linear Motion and
Assembly Technologies

Pneumatics

Service

Rexroth
Bosch Group

3/2, 4/2 and 4/3 directional valves pilot operated

Type WPH, WHH, WMMH, WMDH, WMDAH, WMRH, and WMUH

Operating instructions

RE 24851-B/06.09

English

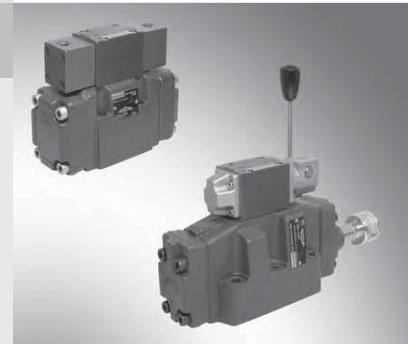

tb0253+0254

Applies to the following types:

3WPH10	4WPH10	H-3WPH10	H-4WPH10	.WPH10...QM
3WPH16	4WPH16	H-3WPH16	H-4WPH16	.WPH16...QM
3WPH22	4WPH22	H-3WPH22	H-4WPH22	.WPH22...QM
3WPH25	4WPH25	H-3WPH25	H-4WPH25	.WPH25...QM
3WPH32	4WPH32	H-3WPH32	H-4WPH32	.WPH32...QM
3WHH10	4WHH10	H-3WHH10	H-4WHH10	.WHH10...QM
3WHH16	4WHH16	H-3WHH16	H-4WHH16	.WHH16...QM
3WHH22	4WHH22	H-3WHH22	H-4WHH22	.WHH22...QM
3WHH25	4WHH25	H-3WHH25	H-4WHH25	.WHH25...QM
3WHH32	4WHH32	H-3WHH32	H-4WHH32	.WHH32...QM
3WM.H10	4WM.H10	H-3WM.H10	H-4WM.H10	.WM.H10...QM
3WM.H16	4WM.H16	H-3WM.H16	H-4WM.H16	.WM.H16...QM
3WM.H22	4WM.H22	H-3WM.H22	H-4WM.H22	.WM.H22...QM
3WM.H25	4WM.H25	H-3WM.H25	H-4WM.H25	.WM.H25...QM
3WM.H32	4WM.H32	H-3WM.H32	H-4WM.H32	.WM.H32...QM

The data specified above only serve to describe the product. No statements concerning a certain condition or suitability for a certain application can be derived from our information. The information given does not release the user from the obligation of own judgment and verification. It must be remembered that our products are subject to a natural process of wear and aging.

© This document, as well as the data, specifications and other information set forth in it, are the exclusive property of Bosch Rexroth AG. It may not be reproduced or given to third parties without its consent.

The cover page shows an example configuration. The product supplied may therefore differ from the photo shown.

The original operating instructions were prepared in German.

Contents

1	About this document	5
1.1	Related documents.....	6
2	General safety instructions	6
2.1	Intended use.....	7
2.2	Improper use.....	7
2.3	Qualification of personnel.....	7
2.4	Safety instructions in this document.....	8
2.5	Adhere to the following instructions.....	8
2.6	Obligations of the operator.....	10
2.7	Safety labels.....	11
2.8	Safety equipment.....	11
3	Scope of delivery	11
4	Product description	12
4.1	Performance description.....	12
4.2	Device description.....	12
4.3	Product identification.....	12
5	Transport and storage	14
5.1	Transport by hand.....	15
5.2	Transport using lifting gear.....	15
5.3	Storage.....	16
6	Assembly	17
6.1	Unpacking.....	17
6.2	Coating the valve before installation.....	17
6.3	Installation conditions.....	18
6.4	Required tools.....	19
6.5	Required accessories.....	19
6.6	Assembling the valve.....	20
6.7	Connecting the spool position monitoring.....	23
6.8	Connecting the pneumatic control.....	24
6.9	Connecting the hydraulic control.....	25
6.10	Changing the pilot oil supply and return.....	25
6.11	Installing the touch guard.....	25
7	Commissioning	26
7.1	First commissioning; re-commissioning after extended standstill.....	26
8	Operation	27
8.1	Operating the manual override (only with valve types ...WPH...).....	27
8.2	Modifying the stroke.....	28
9	Maintenance	29
9.1	Term definition.....	29
9.2	Cleaning and care.....	30
9.3	Inspection and maintenance.....	30
9.4	Repair.....	31
9.5	Spare parts.....	32
10	Decommissioning	34
10.1	Preparing the components for storage/further use.....	34
11	Disassembly and replacement	34
12	Disposal	35
12.1	Environmental protection.....	35
12.2	Return to Bosch Rexroth AG.....	35
12.3	Packagings.....	35
12.4	Materials used.....	35
12.5	Recycling.....	36

Contents

13 Extension and conversion	36
13.1 Optional accessories.....	36
14 Troubleshooting	37
14.1 How to proceed for troubleshooting.....	37
15 Technical data	38
16 Appendix	39
16.1 Project/installation drawings	39
16.2 Address directory.....	39

1 About this document

These operating instructions are valid for Rexroth 3/2-, 4/2-, and 4/3 directional valves, pilot operated.

These instructions contain important information on the safe and appropriate assembly, transport, commissioning, operation, maintenance, disassembly and simple troubleshooting of the valve.

Read these instructions completely, especially chapter "2 General safety instructions" on page 6 before working with the valve.

Target group of these operating instructions

The target group of these operating instructions comprises all groups of persons installing, operating, servicing, and maintaining the products or systems of Bosch Rexroth.

Product scope

Table 1: Main product features

Valve type	Size	Component series	Max. operating pressure A, B, P	Max. operating pressure T	Max. flow
.W.10	10	4X	280 bar	280 bar	160 l/min
.W.16	16	7X	280 bar	250 bar	300 l/min
.W.22	25	7X	280 bar	250 bar	450 l/min
.W.25	25	6X	280 bar	250 bar	700 l/min
.W.32	32	6X	280 bar	250 bar	1100 l/min
H.W.10	10	4X	350 bar	315 bar	160 l/min
H.W.16	16	7X	350 bar	250 bar	300 l/min
H.W.22	25	7X	350 bar	250 bar	450 l/min
H.W.25	25	6X	350 bar	250 bar	700 l/min
H.W.32	32	6X	350 bar	250 bar	1100 l/min

1.1 Related documents

The valve is a system component. Also observe the instructions for the other system components. Also observe the instructions in the following manuals:

- System documentation from the system manufacturer
- Technical data sheets, see table 2
- Technical data sheets and operating instructions of the pilot control valves, see table 2

Table 2: Technical data sheets and operating instructions of the additional functions

Valve type	Technical data sheet	Operating instructions of additional functions
.WPH, H-.WPH, .WHH, H-.WHH	RE 24851, RE 22282	RE 23001-B
.WPH...QM, H-.WPH...QM, .WHH...QM, H-.WHH...QM	RE 24851, RE 22282, RE 24830	RE 23001-B
.WM.H, H-.WM.H	RE 24851, RE 22280	RE 23001-B
.WM.H...QM, H-.WM.H...QM	RE 24851, RE 22280, RE 24830	RE 23001-B



You will find technical data sheets and operating instructions on the Internet at <http://www.boschrexroth.com/Rexroth-IHD/>.

Also observe the generally applicable, legal or otherwise binding regulations of the European or national legislation and the rules for the prevention of accidents and for environmental protection applicable in your country.

2 General safety instructions

The valve has been manufactured according to the accepted rules of current technology. There is, however, still a risk of personal injury or damage to property if the following safety instructions and warnings before instructions contained in these operating instructions are not observed.

- ▶ Read these instructions completely and thoroughly before working with the valve.
- ▶ Keep these instructions in a location where they are accessible to all users at all times.
- ▶ Always include the operating instructions when you pass the valve on to third parties.

2.1 Intended use

The valve is exclusively intended for being integrated in a machine or system or for being assembled with other components to form a machine or system. The product may only be commissioned if it is integrated in the machine/system for which it is designed.

You should observe the operating conditions and performance limits specified in the technical data.

The valve is technical equipment and not designed for private use.

Intended use includes having read and understood these instructions, especially the chapter "2 General safety instructions" on page 6.

Valves with spool position monitoring ...Q...

The valves with spool position monitoring in safety-relevant controls may only be assembled and commissioned by hydraulically and electrically trained experts.

Servicing works may only be carried out by authorized experts or by Bosch Rexroth.

After disassembly of the spool position monitoring, the complete valve may only be assembled and re-adjusted by authorized experts or by Bosch Rexroth.

2.2 Improper use

Any use of the valve other than described in section "2.1 Intended use" is considered as improper.

Conversions exceeding the extent described in these operating instructions are not permitted.

The valve is not suitable for being operated in explosive environments.

2.3 Qualification of personnel

Assembly, commissioning and operation, disassembly, maintenance (including servicing and care) require basic mechanical, electrical, hydraulic and pneumatic knowledge as well as knowledge of the appropriate technical terms. In order to ensure operational safety, these activities may only be carried out by corresponding experts or an instructed person under the direction and supervision of an expert.

Experts are those who can recognize potential hazards and apply the appropriate safety measures due to their professional training, knowledge and experience, as well as their understanding of the relevant conditions pertaining to the work to be undertaken. An expert must observe the relevant specific professional rules.

General safety instructions

2.4 Safety instructions in this document

In these instructions, there are warnings before an instruction whenever there is a risk of personal injury or damage to property. The measures described for preventing these hazards must be observed.





Safety instructions are set out as follows:

SIGNAL WORD	Type of risk!
	Consequences ▶ Precautions

- Warning sign (warning triangle): Draws attention to the hazard
- Signal word: Identifies the degree of hazard
- Type of risk: Specifies the type or source of the hazard
- Consequences: Describes the consequences of non-compliance
- Precautions: Specifies how the hazard can be prevented

The signal words have the following meaning:

Table 3: Signal words/warning signs

Signal word	Application
DANGER! 	Indicates an imminently hazardous situation which, if not avoided, will certainly result in death or serious injury.
WARNING! 	Indicates a potentially hazardous situation which, if not avoided, could result in death or serious injury.
CAUTION! 	Indicates a potentially hazardous situation which, if not avoided, could result in minor or moderate injury or damage to equipment.
	If this information is disregarded, the operating procedure may be impaired.

2.5 Adhere to the following instructions

General notes

- Observe the regulations on accident prevention and environmental protection for the country where the product is used and at the workplace.
- Exclusively use Rexroth valves in good technical order and condition.
- Check the valve for visible defects, for example cracks in the housing or missing lead seals, screws, cover caps or seals.
- Do not modify or retrofit the valve.
- Only use the valve within the performance range provided in the technical data.
- Persons who assemble, operate, disassemble or maintain Rexroth valves must not consume any alcohol, drugs or pharmaceuticals that may affect their ability to react.
- Make sure that all safety devices belonging to the valve are present, have been installed properly and are fully functional. Do not displace, bypass or disable the safety devices.

General safety instructions

- The valve is no safety device. The valve alone must not be assigned the holding of a position; there must be another monitoring feature.
- The valve could block in an undefined position due to internal pollution – e.g. through polluted hydraulic fluid, wear debris or residual dirt from system components. As a result, the driven actuator may no longer be under the operator's control.
- Provide for an appropriate emergency stop function to make sure that the driven actuator can be set to a safe position (e.g. immediate stop).
- Please comply with the specified cleanliness class 20/18/15 in accordance with ISO 4406 (c).
- If it is necessary to disable safety devices, for example for commissioning or maintenance works, always take the appropriate measures to ensure that no hazard to a person's life or health or to property may occur. Also observe the superordinate operating instructions for the machine or system.
- Works or modifications at the spool position monitoring may only be carried out by Bosch Rexroth.

CAUTION!



Risk of burning!

During operation, the valve may even get so hot that you may burn yourself.

- ▶ Allow the valve to cool down sufficiently before touching it.
- ▶ Wear heat-resistant protective clothing, e.g. gloves.
- ▶ Provide for a suitable touch guard.
- ▶ Please also observe ISO 13732-1 and EN 982.

CAUTION!



Risk of burning!

During operation without hydraulic fluid and with simultaneous switching, the valve surface reaches temperatures high enough for you to burn yourself. The max. hydraulic fluid temperature is 80 °C.

- ▶ Prevent the unwanted leaking of hydraulic fluid from the valve.

- The warranty only applies to the delivered configuration.
- The warranty will not apply if the product is incorrectly assembled.
- Do not expose the valve to any mechanical loads under any circumstances. Never use the valve as a handle or step. Do not place any objects on top of it.

During assembly

- Make sure the relevant system component is not under pressure or voltage before assembling the valve or when connecting and disconnecting connectors. Protect the system component against being switched on.
- Lay cables and lines so that they cannot be damaged.
- Before commissioning, make sure that all seals and plugs of the plug-in connection are installed correctly to ensure that they are leakproof and fluids and foreign bodies are prevented from penetrating the valve.
- When assembling, provide for absolute cleanliness in order to prevent welding beads or metal cuttings from getting into the hydraulic lines and causing valve wear or malfunctions.

General safety instructions

During commissioning

- Let the valve acclimate itself for several hours before commissioning, otherwise water may condense in the housing.
- Make sure that all electrical, hydraulic and pneumatic connections are either used or covered. Commission the valve only if it is installed completely.

During cleaning

- Cover all openings with the appropriate protective devices in order to prevent cleaning agents from penetrating the system.
- Never use solvents or aggressive detergents. Only clean the valve using a slightly damp, lint-free cloth. Only use water and a mild cleaning agent, if necessary, to do so.
- Do not use pressure washers for cleaning.

During maintenance

- Perform the prescribed maintenance works at the intervals specified in the operating instructions.
- Make sure that no lines, connections or components are disconnected as long as the system is under pressure and voltage. Protect the system against being switched on.

During disposal

- Dispose of the valve in accordance with the currently applicable national regulations in your country.
- Dispose of the hydraulic fluid in accordance with the currently applicable national regulations in your country.
- Dispose of hydraulic fluid residues according to the applicable safety data sheets for hydraulic fluids.

2.6 Obligations of the operator

The operator of the valve from Bosch Rexroth is bound to provide for personnel training on a regular basis regarding the following subjects:

- Observation and use of the operating instructions as well as the legal stipulations
- Intended use and operation of the Bosch Rexroth valve
- Observation of the instructions from the factory security offices and of the work instructions from the operator
- What to do in an emergency



Bosch Rexroth offers training support in specific fields. You can find an overview of the training contents in the Internet under <http://www.boschrexroth.com/didactic>.

2.7 Safety labels

Table 4: Warning sign

Warning sign	Meaning
	Hot surface warning



Due to the valve's surface temperature, the warning sign "Hot surface warning" must be applied to the end product by the machine/system manufacturer.

2.8 Safety equipment

Personal protective equipment

The operator must provide personal protective equipment (e.g. gloves, safety shoes, safety goggles, overall, etc.).

Touch guard

As protection against the hot valve surfaces, Bosch Rexroth recommends the installation of a touch guard so that unwanted contact with the hot surface can be avoided.

3 Scope of delivery

The scope of delivery includes:

- Valve in accordance with "Technical data sheet" and "Order specification"



Check the scope of delivery for completeness, particularly the seal rings at the valve connection surfaces.

Check the scope of delivery for possible transport damage, also see chapter "5 Transport and storage" on page 14.

Check whether the operating instructions are suitable for the valve.

4 Product description

4.1 Performance description

See "Technical data sheet"



The assignment of the valves to the technical data sheets is contained in table 2 on page 6.

4.2 Device description

See "Technical data sheet"



The assignment of the valves to the technical data sheets is contained in table 2 on page 6.

4.3 Product identification

Information on the name plate

The meaning of the details on the name plate can be found on the basis of the enumerated fields from the following figure and the table.



The position of the name plate at the valve is shown in the technical data sheet.



For the meaning of the information of the other name plates (e.g. pilot control valve, switching time setting, pressure reducing valve, etc.) please refer to the corresponding operating instructions.

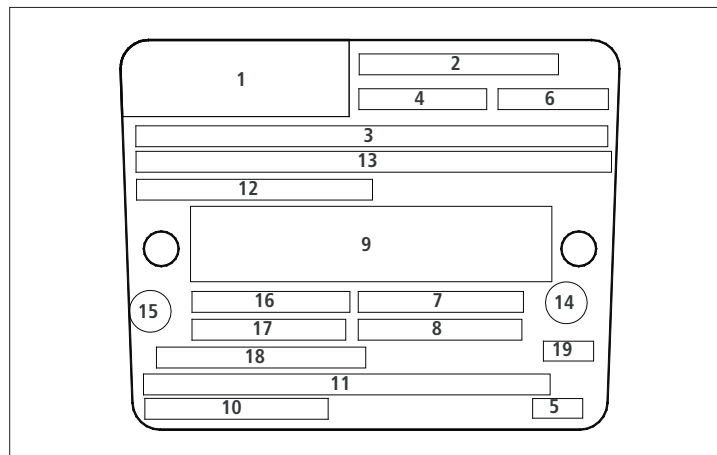

Fig. 1: Name plate size 10

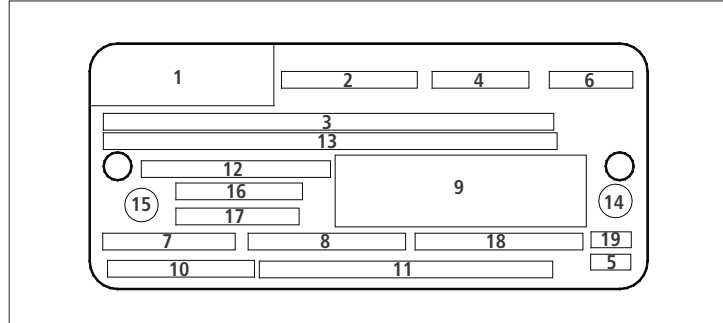

Fig. 2: Name plate size 16, 25, 32

Table 5: About the name plate

No.	Type of information	Information or example
1	Manufacturer's logo	Rexroth
2	Material no. of the valve (= order no.)	e.g.: R9012345678
3	Type designation complete valve	e.g.: .WM.H...¹⁾
4	---	---
5	Manufacturer's factory number	e.g.: 7081
6	Date of manufacture (year and week)	e.g.: FD: 08W01
7	Maximum operating pressure	e.g.: Pmax = 350 bar
8	Ambient temperature range	e.g.: -30 °C ≤ Ta ≤ +50 °C
9	Hydraulic symbol according to ISO 1219	Graphic
10	Designation of origin	Made in Germany
11	Name and address of the manufacturer	BOSCH REXROTH AG D-97816 LOHR
12	Customer or fabrication order number	e.g.: 123456789012345678
13	Customer material number or additional information	e.g.: CNR: 1234567890
14	---	---
15	---	---
16	---	---
17	---	---
18	---	---
19	---	---

¹⁾ For the meaning of the individual details of the type designation please refer to the "Technical data sheet" of the corresponding valve.



For information on the name plate of the pilot control valve please refer to the operating instructions of the pilot control valve.

5 Transport and storage

DANGER!



Risk of personal injury and damage to property!

In case of improper transport, the valve may fall down and cause damage to the valve and/or injuries as the components may be sharp-edged, oily, unstable, loose and bulky.

- ▶ Provide for a stable position during transport to the place of installation.
- ▶ Use personal protective equipment (like e.g. gloves, working shoes, safety goggles, working clothes, etc.).
- ▶ Comply with the national laws and regulations regarding occupational health and safety and transport.

CAUTION!



Risk of health hazards!

When lifting the valves with high weight, there is the risk of health hazards.

- ▶ In manual transport, use a suitable lifting, putting down and moving technique or use suitable lifting gear.

There are the following possibilities for the transport, depending on the weight:

- Transport by hand (valves with low weight; in case of short-term lifting, the latter should not exceed 15 kg for women and 25 kg for men).
- Transport by means of lifting gear and corresponding accessories (valves with high weight and in case of longer transport).



The information on the weight of your valve is contained in the Technical data sheet.



Transport damage must be reported within one week to Bosch Rexroth to the following address:

Bosch Rexroth AG
Service Industriehydraulik [Industrial hydraulics]
Bürgermeister-Dr.-Nebel-Straße 8
97816 Lohr am Main
Germany

Phone +49 (93 52) 18-46 66

Fax +49 (93 52) 18-33 63

For transporting and storing the product always observe the environmental conditions specified in the technical data (see "Technical data sheet").

5.1 Transport by hand

DANGER!



Risk of personal injury and damage to property!

In case of improper transport, the valve may fall down and cause damage to the valve and/or injuries.

- ▶ Use personal protective equipment (like e.g. gloves, working shoes, safety goggles, working clothes, etc.).
- ▶ Don't transport the valve using components with little stability, e.g. pilot control valve and spool position monitoring.

In case of transport by hand, the following points are to be observed:

- ▶ Use a suitable lifting, putting down and moving technique.
- ▶ Use personal protective equipment (like e.g. gloves, working shoes, safety goggles, working clothes, etc.).
- ▶ Don't transport the valve using components with little stability, e.g. pilot control valve and spool position monitoring.
- ▶ Don't jam the valve.
- ▶ Put the valve carefully onto the contact surface in order not to damage it.

5.2 Transport using lifting gear

WARNING!



Crush injuries and fractures!

Valves that are falling down may cause serious injuries, e.g. crush injuries, fractures.

- ▶ Use suitable lifting gear for the transport.
- ▶ Observe the prescribed position of lifting straps.

DANGER!



Risk of personal injury and damage to property!

In case of improper transport, the valve may fall down and cause damage to the valve and/or injuries. Parts of the valve may be torn off or deformed.

- ▶ In order to transport the valve, don't fasten it using components with little stability, e.g. pilot control valve and spool position monitoring.
- ▶ Make sure that the attachment devices don't contact components with little stability, e.g. pilot control valve and spool position monitoring.

In transport, consider the following aspects:

- Properties of the load (e.g. weight, center of gravity, mounting and attachment points).
- Type of attachment or pick-up of the load.

Ensure that the lifting gear's lifting capacity is sufficient in order to transport the valve without risk.

Use textile attachment devices - according to DIN EN 1492-2.

More information regarding the transport is available from Bosch Rexroth.



Transport and storage

- ▶ Put a transport belt around the valve so that it does not lie over the attachment parts (e.g. pilot control valve and spool position monitoring), see figure 3.

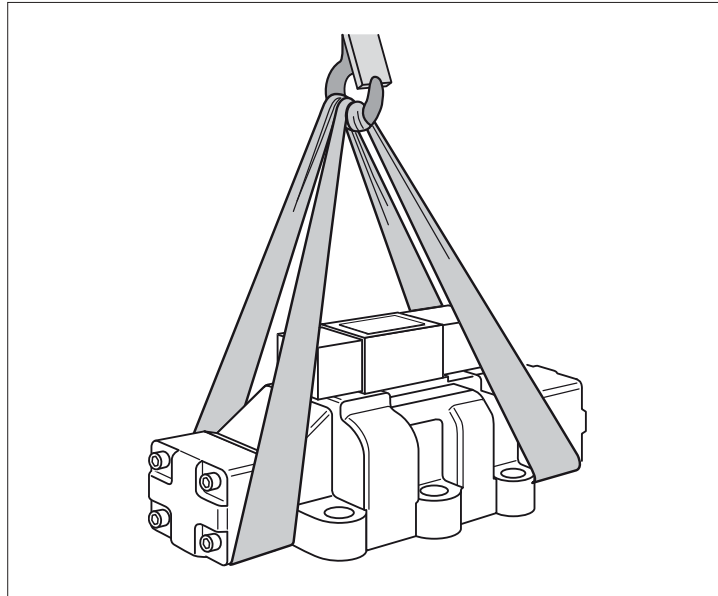

Fig. 3: Position of the lifting strap

5.3 Storage

Coming from the works, the valve is suitable for being stored up to six months according to the following criteria:

- Do not store outside, but only under a roof or in a well-ventilated room.
- Protect against soil humidity: Store in shelves or on a wood pallet.
- Cover with foil as protection against dust and dirt.
- All connections at the valve must be covered with plugs.
- At all connection surfaces and blank parts, there must be preservative protection. If there is no or insufficient preservative protection, they are to be preserved using Bran-O-Rost protective oil.
- After opening the transport packaging, it must be closed properly again for the storage.



In case of storage of more than six months or in case of sea transport, coordination with Bosch Rexroth is required.

6 Assembly

6.1 Unpacking

Dispose of the packaging in accordance with the national regulations of your country.

Risk of personal injuries and damage to property!

In case of improper opening of the packaging, components of the valve may fall out and cause damage to the components or even injuries as the components may be sharp-edged, heavy, oily, unstable, loose and bulky.

- ▶ Put the packaging on a level ground with sufficient load carrying capacity.
- ▶ Take the device out and provide for a stable position during transport to the place of installation.
- ▶ Use personal protective equipment (like e.g. gloves, working shoes, safety goggles, working clothes, etc.).

6.2 Coating the valve before installation

If the valve is to be painted before the assembly, please observe the following:

- ▶ Protect the hydraulic ports against paint application by screwing-in plastic threaded plugs completely beforehand.
- ▶ Protect the mounting bores against paint application.
- ▶ Mask the valve connection surfaces as well as the connection and end plates carefully before coating so that no dirt or paint may enter.
- ▶ Protect the name plate against paint application.
- ▶ Protect existing information signs against paint application.
- ▶ Mask the connector of the electrical connections and make sure not to cause any damage to the connector.



For the valve types ...QM..., the spool position monitoring must not be painted.



When removing the coating protection and the plastic threaded plugs make sure that no paint chips or other foreign bodies enter the valve. The name plate must be readable after coating.



If you want to coat the valve after the assembly, the same points as when coating the valve before the assembly have to be observed.

6.3 Installation conditions

For installing the product always observe the environmental conditions specified in the technical data (see "Technical data sheet").

Installation position

See "Technical data sheet"



The assignment of the valves to the technical data sheets is contained in table 2 on page 6.

Requirements on the valve connection plate

WARNING!



Loss of valve function due to overheating

Falling below the minimum values causes the risk of excess heating of the solenoid coil and thus of possible malfunctions.

- ▶ Observe the specified minimum distance when installing several valves to a valve battery.
- ▶ Observe the specified minimum size and heat conductivity of the valve connection plate.

For recommended subplates, see section "13.1 Optional accessories" on page 36.

Note on the valve use

- ▶ Observe the following information during the project planning:

WARNING!



Damage to the valve, the supply line, and other hydraulic components

Be aware of possible pressure intensification if the valve is connected to the chamber on the piston rod side of a single-rod cylinder. If the outflow of the hydraulic medium from this chamber is obstructed, pressure on the cylinder may result in a pressure intensification that may damage cylinder chamber, supply line, and valve.

- ▶ Make sure that there is adequate mechanical screening against any high-pressure water jet that may be used during cleaning.

If due to the operating conditions to be expected during the switching actions flows must be anticipated lying outside the valve's performance limits evident from the characteristic curve, a throttle insert of type B must be used in channel P of the pilot control valve for flow limitation.



For more information on throttle inserts refer to the related Technical data sheets and/or operating instructions of the pilot control valve.

In order to safely switch the valve or keep it in its spool position, the performance limits must be complied with, see Technical data sheet.



The counterpressure at port T must not exceed the value specified in the Technical data sheet.

- Pressure peaks in the joint return line of more than one valve can result in unwanted spool movements and thus cause undesired switching processes. It is recommended to use separate return lines.
- Ports P, A, B and T are clearly fixed according to their function and must not be swapped arbitrarily or closed. The flow is only permitted in the direction of the arrow specified in the Technical data sheet.

6.4 Required tools

In order to install the valve, you need standard tools only.

6.5 Required accessories

In order to assemble the valve, you need the following accessories, which are not included in the delivery and can be ordered from Bosch Rexroth.

- Valve mounting screws
Due to reasons of stability, only the following valve mounting screws have to be used.

Table 6: Valve mounting screws

Valve type	Hexagon socket head cap screws	Quantity	Tightening torque ¹⁾	Material no.
..W.10	ISO 4762 - M6 x 45 – 10.9 - flZn-240h-L	4	12.5 Nm ± 10 % ²⁾	R913000258
	1/4-20 UNC x 1 3/4" ASTM-A574	4	- ³⁾	Self procurement
..W.16	ISO 4762 - M10 x 60 – 10.9 - flZn-240h-L	4	75 Nm ± 10 % ²⁾	R913000116
	ISO 4762 - M6 x 60 – 10.9 - flZn-240h-L	2	12.5 Nm ± 10 % ²⁾	R978800115
	3/8-16 UNC x 1 3/4" ASTM-A574	4	- ³⁾	Self procurement
	1/4-20 UNC x 2 1/4" ASTM-A574	2	- ³⁾	Self procurement
..W.22 ..W.25	ISO 4762 - M12 x 60 – 10.9 - flZn-240h-L	6	130 Nm ± 10 % ²⁾	R913000121
	1/2-13 UNC x 2 1/2" ASTM-A574	6	- ³⁾	Self procurement
..W.32	ISO 4762 - M20 x 80 – 10.9 - flZn-240h-L	6	430 Nm ± 10 % ²⁾	R913035246
	3/4-10 UNC x 3 1/4" ASTM-A574	6	- ³⁾	Self procurement

¹⁾ Please use a torque power screwdriver with a tolerance of ≤ 10 % for tightening purposes.

²⁾ Friction coefficient μ_{total} 0.09 - 0.14 according to VDA 235-101

³⁾ The operator must ensure for self-procured valve mounting screws that the tightening torque for the valve mounting screws is complied with and sealing function is guaranteed.

Address for ordering accessories and valves

The addresses of our responsible sales companies can be found on the Internet at <http://www.boschrexroth.de> and in section "16.2 Address directory" on page 39.

6.6 Assembling the valve



Have sufficiently dimensioned collection containers, enough cleaning cloths and medium-binding materials ready in order to collect or bind leaking medium.

DANGER!



Risk of personal injury and damage to property!

Incorrectly assembled valves can cause substantial material damage and personal injuries. An improperly attached valve may move in an uncontrolled manner and damage other system components and also cause errors in the hydraulic circuit or may lose oil and pollute the environment.

- ▶ Before any work such as assembly or disassembly is carried out at the valve, the hydraulic system must be depressurized and the electrical control system de-energized.
- ▶ Assembly of the valve requires basic mechanical, hydraulic, pneumatic and electrical knowledge. Only qualified personnel (see section "2.3 Qualification of personnel" on page 7) are authorized to assemble the valve.
- ▶ Ensure that the valve is attached securely.

CAUTION!



Wear, tear and malfunctions!

The cleanliness of the hydraulic fluid has a considerable impact on the cleanliness and service life of the hydraulic system as a whole. Any pollution/contamination of the hydraulic fluid will result in wear and malfunctions. Particularly foreign bodies like e.g. welding beads or metal cuttings in the hydraulic lines may damage the valve.

- ▶ Always ensure absolute cleanliness.
- ▶ Assemble the valve free from any pollution.
- ▶ Make sure that all connections, hydraulic lines and attachment parts (e.g. measuring devices) are clean.
- ▶ Ensure that also when sealing the connections, no contaminations are able to penetrate.
- ▶ Ensure that no cleaning agents are able to penetrate the hydraulic system.
- ▶ Do not use cotton waste or linting cloths for cleaning.
- ▶ Do not under any circumstances use hemp as a sealant.

Installing the valve in the system

CAUTION!



Risk due to the use of an improper valve

Installing an improper valve may result in uncontrolled activities and in personal injuries or damage to other system components.

- ▶ Check based on the type designation on the name plate of the valve whether there is the correct valve type.
- ▶ Check the scope of delivery for completeness, particularly the seal rings at the valve connection surfaces.
- ▶ Check the scope of delivery for possible transport damage.
- ▶ Check whether the operating instructions are suitable for the valve.
- ▶ Please observe all safety instructions.

1. Before any assembly and disassembly work starts, the surroundings must be cleaned so that no dirt can get into the oil circuit. Only non-linting fabric or special paper may be used for cleaning.
2. Remove existing preservative agent.
3. Check valve mounting face for required surface quality (see "Technical data sheet", unit dimensions). Remove the protective plate from the valve and keep it safe for returns in case any repairs become necessary later.
4. Dry the valve connection surface using suitable cleaning materials.
5. Check the seal rings at the valve connection surface for completeness. Other sealants are inadmissible.
6. Check whether at the subplate, the pressure connection line is connected with P and the return line with T.



Confusing P and T can lead to damage at the valve when the system is pressurized.

7. Put the valve on the valve mounting face.
8. When using the subplates mentioned in section "13.1 Optional accessories" on page 36 or when installing on comparable cast iron installation surfaces, tighten all mounting screws with a torque power screwdriver and to the specified torque, see table 6 on page 19.

This tightening torque refers to the maximum admissible operating pressure.

If the valve is to be used with reduced maximum pressure and installed on valve mounting faces made of another material (observe minimum heat conductivity!), a lower tightening torque has to be used to rule out damage, if necessary.

WARNING!



Risk of material damage and personal injuries due to improper installation!

The use of mounting material not approved of by Bosch Rexroth and erroneous installation may result in damage to the valve, adjacent components, as well as personal injuries due to escaping pressurized hydraulic oil.

- ▶ Always fasten the valve with all mounting screws as otherwise, leak-proofness is not guaranteed. See "Technical data sheet".
- ▶ For reasons of stability, only use the valve mounting screws mentioned in table 6 on page 19!
- ▶ Check the structure of the hydraulic product using the circuit diagrams, device lists and assembly plans.
- ▶ Clarify possible discrepancies with the responsible persons.

Assembly

Hydraulic connection of the valve

1. Depressurize the relevant part of the system.

CAUTION!



Risk of injury when assembling under pressure!

If you fail to depressurize the product before starting the assembly, you may suffer injury and also damage the unit or system components.

- ▶ Depressurize the corresponding part of the system before installing the valve.

CAUTION!



Missing seals and caps will lead to loss of protection class IP 67!

Liquids and foreign bodies may penetrate and destroy the valve.

- ▶ Ensure before the assembly that all seals and caps of the plug-in connections are tight.

CAUTION!



Damage to the valve!

When assembling hydraulic lines and hoses under mechanical stress, they are exposed to additional mechanical forces during operation which reduce the service life of the valve and the entire machine or system.

- ▶ Assemble lines and hoses without mechanical stress.

2. Establish all connections; in this connection, observe the operating instructions of the system.
3. Make sure that pipes and/or hoses are connected to all ports and/or that the ports are sealed with screw plugs.
4. Carry out a special check to make sure that the cap nuts and flanges are correctly tightened at the pipe fittings and flanges.

Mark all checked fittings, e.g. with permanent markers.



5. Make sure that all pipes and hose assemblies and every combination of connection pieces, couplings or connection points with hoses or pipes are checked for their operational safety by someone who has the appropriate knowledge and experience.

6.7 Connecting the spool position monitoring



The following description applies to the following valve types:
...QM....

Also observe the information in the Technical data sheets.

The assignment of the valves to the Technical data sheets is contained in table 2 on page 6.

- ▶ De-energize the relevant part of the system.

CAUTION!



Risk of injury when assembling under voltage!

If you do not switch off voltage supply before assembling the product, you may get injured or the valve or system components may be damaged.

- ▶ Always switch off power supply to the relevant part of the system before assembling the valve.

CAUTION!



Risk of personal injury and damage to property!

Incorrect energy supply may lead to uncontrolled valve positions. These could result in possible malfunctions or failure of the valve and cause injuries.

- ▶ Always connect the earthing connection of the valve with the appropriate earthing system in your installation.
- ▶ Only use a mains adapter with safe disconnection.
- ▶ Always comply with the country-specific regulations.

CAUTION!



Risk of short-circuit due to missing seals and caps!

Fluids may enter the valve and cause a short-circuit.

- ▶ Before commissioning, ensure that all seals and plugs of the plug-in connection are leak-proof.

WARNING!



Risk due to improper connection wiring

The valve may only be connected by or under the supervision of a specialized electrician.

The lines used have to be suitable for operating temperatures of $-30\text{ }^{\circ}\text{C} \dots < +100\text{ }^{\circ}\text{C}$.

For details on suitable connection cables, see "Technical notes for the cable" in the "Technical data sheet" (RE 24830 and RE 08006).

- ▶ De-energize the connection line before the assembly.
- ▶ Connect the protective earthing conductor and the earthing properly.
- ▶ Avoid sharp bends in the connection line and the litz wires in order to avoid short-circuits and interruptions.
- ▶ Only mount the cable and line entry according to the assembly instructions. Check before the assembly whether the individual components of the cable and line entry are complete and whether the sealing elements are undamaged.
- ▶ During the assembly, ensure leak-tightness between cable, cable and line entry.
- ▶ Route the connection line(s) in a pull-relieved form. The first mounting point must be within 15 cm of the cable entry.
- ▶ Use finely stranded conductors only if they have pressed-on conductor sleeves.
- ▶ Only use lines meeting the requirements for the terminal areas of the connection terminals, see "Technical data sheet".

Assembly



Only the mating connectors specified in the "Technical data sheet" (RE 24830 and RE 08006) or mating connectors of the same type may be used. Observe the installation instructions printed on the packaging of the mating connector and the tightening torques specified there.

1. Cut heat shrinkable tubings to length and push the same over the litz wires of the control line to insulate the solder joints and the uncovered parts at a later point in time.
2. Solder the litz wires of the control line to the solder buckets of the contact sockets of the mating connector according to the specified connection wiring.
Or
Crimp the litz wires of the control line to the contact sockets of the mating connector according to the specified connection wiring.
3. Check for proper assignment of the litz wires to the contact sockets with the help of a continuity tester.
4. Position heat shrinkable tubings over solder joints and uncovered parts and shrink the same on.
5. Check the mutual isolation of the contact sockets by means of a continuity tester.
6. Assemble the mating connector according to the installation instructions.
7. Plug and subsequently screw the mating connector (on) to the connector of the spool position monitoring.



Observe the installation instructions printed on the packaging of the mating connector.

6.8 Connecting the pneumatic control



The following description applies to the following valve types:
..WPH....

1. Before assembly and disassembly, it is imperative that you provide for a clean environment, so that no dirt can enter the pneumatic system. Only non-linting fabric or special paper may be used for cleaning.
2. Screw in the fitting at the pneumatic connections and tighten it with the prescribed tightening torque, see table 7.

Table 7: Fitting

Thread	Tightening torque Fitting
G1/4	40 Nm
G1/8	20 Nm

This tightening torque refers to the maximum admissible operating pressure.

3. Lay the connection lines according to the applicable technical rules.
4. Make sure that all pipes and hose assemblies and every combination of connection pieces, couplings or connection points with hoses or pipes are checked for their operational safety by someone who has the appropriate knowledge and experience.

6.9 Connecting the hydraulic control



The following description applies to the following valve types:
..WHH....

1. Before any assembly and disassembly work starts, the surroundings must be cleaned so that no dirt can get into the oil circuit. Only non-linting fabric or special paper may be used for cleaning.
2. Screw in the fitting at the hydraulic connections and tighten it with the prescribed tightening torque, see table 8.

Table 8: Fitting

Thread	Tightening torque Fitting
G1/4	40 Nm
G1/8	20 Nm

This tightening torque refers to the maximum admissible operating pressure.

3. Lay the connection lines according to the applicable technical rules.
4. Make sure that all pipes and hose assemblies and every combination of connection pieces, couplings or connection points with hoses or pipes are checked for their operational safety by someone who has the appropriate knowledge and experience.

6.10 Changing the pilot oil supply and return

The valve can optionally be operated with internal or external pilot oil supply and return. The delivery condition of the valve results from the type designation, see ordering code in the "Technical data sheet".

The valve can be converted to other operating modes; this may, however, only be done by the Bosch Rexroth Service or any other authorized Bosch Rexroth department.



After a conversion of the pilot oil supply and/or return, the coded type designation printed on the name plate of the valve does not specify the current status any more and must thus be corrected.

Thus, we recommend a conversion and the update of the name plate by the Bosch Rexroth Service.

6.11 Installing the touch guard

CAUTION!



Risk of burning!

The valve considerably heats up during operation. The valve gets so hot during operation that you may burn yourself.

- ▶ Install a touch guard.

As protection against the hot valve surfaces, Bosch Rexroth recommends the installation of a touch guard so that unwanted contact with the hot surface can be avoided.

7 Commissioning

CAUTION!



Risk of personal injury and damage to property!

Commissioning of the valve requires basic hydraulic, pneumatic and electrical knowledge.

- ▶ Only qualified personnel (see section "2.3 Qualification of personnel" on page 7) are authorized to commission the valve.

7.1 First commissioning; re-commissioning after extended standstill

Proceed as described in the following sections to commission the valve.

Check the electrical connections (only type ...QM...)

- ▶ Electrical connections must be checked for proper condition by or under the guidance and supervision of a specialized electrician before the initial or any recommissioning.

Bleeding the hydraulic system



Observe the operating instructions of the unit or system in which the valve is used.

- ▶ Before the actual operation, switch the valve several times with reduced pressure (50 % operating pressure). This will expel any remaining air from the valve. Mechanical damage due to inadmissibly high acceleration of the fluid and the valve spool is thus avoided and the valve's service life is extended.



Do not switch the valve under operating pressure, as this may cause damage.



With valve types ..WPH... you can also achieve the switching movement of the valve spool necessary for the bleeding process by manual actuation of the manual override, see section "8.1 Operating the manual override" (only with valve types ...WPH...)" on page 27.

Performing a leakage test

- ▶ Check whether during operation, hydraulic medium leaks at the valve and at the connections.
- ▶ Check whether there is an internal leakage. This has to be done according to the possibilities offered by the hydraulic system.



There may be an internal leakage due to the specific valve. This has, however, no influence on the valve's functionality. For information regarding this topic, please contact Bosch Rexroth.

Performing a functional test

- ▶ If possible, firstly check hydraulic functions in a controlled form and with low pressure; observe the operating instructions of the hydraulic system into which the valve has been installed.

8 Operation



See operating instructions of the hydraulic system into which the valve has been installed.

8.1 Operating the manual override (only with valve types ...WPH...)



Operation of the manual override is only applicable for the subsequently listed type, see table 9:
The type can be determined via the component in the type designation, see table 5 on page 13 or the "Technical data sheet"

Table 9: Explanation on the manual overrides

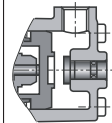
Type	Description	Figure
N	Manual override	

Per actuation side, the valves are provided with a manual override. Using this manual override, the switching function of the valve can be triggered.

The manual override is only intended for manual operation.

The manual override is located at the actuation side showing away from the valve.



A manual override is only reasonable with valves if the pressure in the tank channel of the valve does not exceed 50 bar. Above this pressure value, the actuating force that is to be applied is too large and there is a risk of injury if the tool slips.

DANGER!



Risk of personal injury and damage to property!

If the manual override is operated in an uncontrolled manner, there is the risk of damaging the system.

- ▶ Only operate the manual override if it has been ensured that this will not trigger any dangerous working movement of the connected actuator!

Operation

CAUTION!



Risk of personal injury and damage to property!

There is the risk of damaging the manual override.

The manual override is only intended for short-term manual actuation and must not be brought into a certain spool position for a longer period or permanently using mechanical equipment.

- ▶ Actuate the manual override using the tool!

- ▶ Using the tool, push the manual override in the direction of the valve housing.

8.2 Modifying the stroke

WARNING!



Risk of personal injuries and damage to property due to pressurized and energized system components.

Works on pressurized and energized system components entail the risk of injuries caused by escaping hydraulic oil or electric shocks.

- ▶ Before modifying the stroke setting, check if the hydraulic system is depressurized and if the electrical control is de-energized.

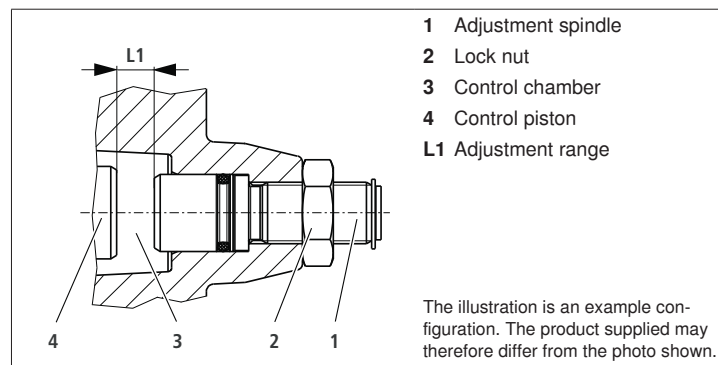

Fig. 4: Stroke adjustment

Table 10: Maximum adjustment range

Size	Adjustment range L1
10	6.5 mm
16	10 mm
25 (type 4W.H22)	9.5 mm
25 (type 4W.H25)	12.5 mm
32	15 mm

1. Loosen lock nut (2).

2. Modify stroke by rotating the adjustment spindle (1).
 - In order to reduce the stroke, turn the adjustment spindle (1) to the right (clockwise).
 - In order to increase the stroke, turn the adjustment spindle (1) to the left (counter-clockwise).
 - Size 10: 1 rotation = 1.0 mm adjustment travel
 - Sizes 16 to 32: 1 rotation = 1.5 mm adjustment travel



3. Tighten lock nut (2) with a torque power screwdriver with $\pm 10\%$ tolerance clockwise, see table 11.

Table 11: Details with regard to the adjustment spindle

Size	Width across flats Adjustment spindle	Lock nut (hexagon nut)	Tightening torque lock nut	Material no.
10	5	DIN936-M10x1-17H-A3C	15.5 Nm $\pm 15\%$	R900003781
16	8	DIN936-M16x1.5-17H	35.5 Nm $\pm 15\%$	R900003773
25 (type ..W.22...)	8	DIN936-M16x1.5-17H	35.5 Nm $\pm 15\%$	R900003773
25 (type ..W.25...)	8	DIN936-M16x1.5-17H	35.5 Nm $\pm 15\%$	R900003773
32	12	DIN936-M24x1.5-17HA3C	80.0 Nm $\pm 15\%$	R900005580



Further details for mounting options are available in the "Technical data sheet".

9 Maintenance

9.1 Term definition

In accordance with DIN 31051:2003-6, the term maintenance means the combination of all technical and administrative measures and measures taken by the management during the life cycle of an item in order to maintain the functional condition or to return to the same, so that the item is able to meet the required function.

These measures can be classified into:

- **Maintenance** (measures to delay the decrease of the existing wear reserve)
- **Inspection** (measures to determine and assess the actual condition of an item, including the determination of the cause of wear and the derivation of the required consequences for a future use)
- **Repair** (measures to return an item to the functional state, except for improvements)
- **Improvement** (combination of all technical and administrative measures and measures taken by the management to increase the functional safety of an item, without modifying the function required)

9.2 Cleaning and care

CAUTION!



Penetrating dirt and liquids will cause faults!

Safe function of the valve is no longer ensured.

- ▶ Always provide for absolute cleanness when working on the valve.
- ▶ Do not use a pressure washer.

CAUTION!



Damage to the surface from solvents and aggressive cleaning agents!

Aggressive detergents may damage the seals and the surface of the valve and let them age faster.

- ▶ Never use solvents or aggressive detergents.
- ▶ Do not use pressure washers for cleaning.

CAUTION!



Damage to the hydraulic system and seals!

A pressure washer's water pressure could damage the hydraulic system and the seals of the valve. The water displaces the oil from the hydraulic system and seals.

- ▶ Do not use pressure washers for cleaning.

- ▶ Cover all openings with appropriate protective caps.
- ▶ Check that all seals and plugs for the plug-in connections are firmly fitted so that no humidity can penetrate the valve during cleaning.
- ▶ Only clean the valve using a damp, lint-free cloth. Only use water and a mild cleaning agent, if necessary, to do so.
- ▶ Flush the hydraulic system if necessary. Replace the fluid filter or the hydraulic medium.

9.3 Inspection and maintenance



Dust accumulations on the valve have to be removed at regular intervals.

The following inspection, testing and maintenance works are to be carried out regularly. Also considering the operating conditions, the corresponding intervals are to be chosen so that defects that can reasonably be expected are dealt with in good time. However, the inspection has to be implemented at least every three years counting from the manufacturing date of the valve. The manufacturing date of the valve can be found on the name plate, see section "4.3 Product identification" on page 12.



The inspection must also be carried out if the valve is only stored but not used! Ordering details for seal kits can be found in section "9.5 Spare parts" on page 32.



Have sufficiently dimensioned collection containers, enough cleaning cloths and medium-binding materials ready in order to collect or bind leaking medium.

1. Switch off power supply to the electrical connection line (only with valve type ...QM...).
2. Remove external coarse dirt.
3. Check all external fittings for completeness.
4. Check the valve for external leakage, replace seals if applicable, see section "Remedying leakage".



Information regarding the determination of the internal leakage is available from Bosch Rexroth.

Additional works with valves with spool position monitoring

The following description applies to the following valve types:
...QM....



1. Check the connection line for damage. If damage is visible, replace the connection line.
2. Loosen the mating connector and remove the mating connector.
3. Check the seal of the mating connector for damage. If damage is visible, the mating connector must be completely replaced. You will find ordering details for the mating connector in section "9.5 Spare parts" on page 32, see also section "6.7 Connecting the spool position monitoring" on page 23.
4. Plug and subsequently screw the mating connector (on) to the connector of the spool position monitoring.

9.4 Repair

Bosch Rexroth offers a wide range of repair services for the valve.

- ▶ Only use genuine spare parts from Bosch Rexroth for repairing the Rexroth product.
- ▶ Tested and pre-assembled original Rexroth assemblies allow for successful repair requiring only little time.

Safety instructions regarding repairs

For repair works, the valve may only be disassembled to the extent described in the operating instructions.

Defective parts may only be replaced by new, interchangeable, tested components in original equipment quality.

- ▶ Clean the external environment of fittings and devices before the disassembly. Do not use cotton waste for the cleaning.
- ▶ Close all openings using protective caps.

Remedying leakage

External leakage at the valve connection surface can be remedied on site, see section "Remedying leakage at the valve connection surface" on page 32.

In case of internal leakage, the valve must be replaced completely.

Maintenance

Rectifying leakage at the valve connection surface

- ▶ Remove the valve, see chapter "11 Removal and replacement" on page 34.
- ▶ Check the seal recesses on the valve connection surface for cleanliness and damage.
- ▶ Dry the valve connection surface and the valve mounting face using suitable cleaning materials.
- ▶ Fit the new seals.
- ▶ Re-install the valve at the valve contact surface, see chapter "6. Assembly" on page 17.

9.5 Spare parts

CAUTION!



Damage to property and personal injuries due to faulty spare parts!

Spare parts that do not meet the technical requirements specified by Bosch Rexroth may cause personal injuries and damage to property.

- ▶ Only use genuine spare parts from Bosch Rexroth.

- ▶ Order spare parts in writing. In urgent cases you can also order by phone, but you are kindly requested to confirm your order in writing e.g. by fax.
- ▶ Please send your spare parts order to the Bosch Rexroth service next to you or directly to the headquarters (see section 16.2 "Address directory" on page 39).
- ▶ When ordering spare parts, please indicate the following information from the product's name plate:
 - The serial number
- ▶ Please indicate the following details from the parts list:
 - The material number
- ▶ Additionally indicate:
 - The desired number of spare parts
 - The required type of dispatch (e.g. as parcel, freight, air freight, by courier etc.).

The following spare parts are available for the valve:

- Seals



When selecting the seals, observe the information on the name plate.

Table 12: NBR seal kits up to 280 bar

Size	Material no.
Size 10	R900306343
Size 16	R900306345
Size 25 (7X)	R900306349
Size 25 (6X)	R900309827
Size 32	R900309829

Table 13: NBR seal kits up to 350 bar

Size	Material no.
Size 10	R961004011
Size 16	R961004014
Size 25 (7X)	R961004016
Size 25 (6X)	R961004018
Size 32	R961004020

Table 14: FKM seal kits up to 280 bar

Size	Material no.
Size 10	R900306344
Size 16	R900306346
Size 25 (7X)	R900309825
Size 25 (6X)	R900309826
Size 32	R900309830

Table 15: FKM seal kits up to 350 bar

Size	Material no.
Size 10	R961004013
Size 16	R961004015
Size 25 (7X)	R961004017
Size 25 (6X)	R961004019
Size 32	R961004021



For information on the seal kits of the pilot control valves please refer to the operating instructions.



Please observe the suitability of the sealing materials for the hydraulic medium used! See "Technical data sheet"

- Mating connectors for valve type ...QM...



For more information on the mating connectors refer to the Technical data sheets "RE 24830" and "RE 08006".

- Pilot control valve



For more information on pilot control valves refer to the related Technical data sheets and/or operating instructions. Observe the name plate of the pilot control valve.

Please refer to the address directory on the Internet at <http://www.boschrexroth.com/service> and in section "16.2 Address directory" on page 39.

10 Decommissioning

The valve is a component that does not require decommissioning. As a result, this chapter of the instructions does not contain any information.

For details about how to disassemble or replace the valve, please refer to chapter "11 Disassembly and replacement".

10.1 Preparing the components for storage/further use

- ▶ Clean the valve as specified in section "9.2 Cleaning and care" on page 30.
- ▶ Please observe the notes in the "Technical data sheet".

11 Disassembly and replacement

WARNING!



Risk of personal injuries and damage to property due to pressurized and energized system components.

Works on pressurized and energized system components entail the risk of injuries caused by escaping hydraulic oil or electric shocks.

- ▶ Ensure before the disassembly that the hydraulic system is depressurized and the electrical control is de-energized.



With valve types ...QM..., the spool position monitoring must not be removed from the valve, see section "2.1 Intended use" on page 7.



Have sufficiently dimensioned collection containers, enough cleaning cloths and medium-binding materials ready in order to collect or bind leaking medium.

1. De-energize and depressurize the relevant part of the system.
2. Disconnect the electrical connections in a professional way.
3. Have a container ready for collecting the escaping hydraulic fluid.
4. Only loosen the valve mounting screws using a suitable tool.
5. Remove the mounting screws and take off the valve from the valve mounting face.



Do not loosen the fitting between pilot control valve and main valve.

6. Collect the escaping hydraulic fluid in the provided container and dispose of it properly.
7. If the valve is to be returned to the manufacturer for repair, close the valve connection surface using the supplied protective plate or protect it using equivalent packaging in order to avoid pollution and damage.
8. Seal the subplate in order to avoid pollution.

When exchanging the valve, the following steps are analog to the assembly, see chapter "6 Assembly" on page 17.

12 Disposal

12.1 Environmental protection

Careless disposal of the valve and the hydraulic fluid could lead to pollution of the environment.

- ▶ Thus, dispose of the valve and the hydraulic fluid in accordance with the currently applicable national regulations in your country.
- ▶ Dispose of hydraulic fluid residues according to the respective safety data sheets valid for these hydraulic fluids.
- ▶ Please observe the following supplied notes for the environmentally-friendly disposal of the valve.

12.2 Return to Bosch Rexroth AG

The products manufactured by us can be returned to us for disposal purposes at no costs. However, the precondition is that there are no spurious adherences or any other contamination. The hydraulic products have to be discharged before they are returned. Furthermore, there must be no inappropriate foreign matter or third party components when products are returned.

The products have to be sent free to the door to the following address:

Bosch Rexroth AG
Service Industriehydraulik [Industrial hydraulics]
Bürgermeister-Dr.-Nebel-Straße 8
97816 Lohr am Main
Germany

12.3 Packagings

Upon request, reusable systems can be used for regular deliveries.

The materials for one-way packagings are mostly cardboard, wood, and styro-foam. They can be of without any problems. Due to ecological reasons, one-way packagings should not be used for returning products to us.

12.4 Materials used

Our products do not contain any hazardous materials that could be released during intended use. Normally, no adverse effects on human beings and on the environment have to be expected.

The products essentially consist of:

- Cast iron
- Steel
- Aluminum
- Copper
- Plastic materials
- Elastomers

12.5 Recycling

Due to the high share of metal, the products can mostly be recycled. In order to achieve an ideal metal recovery, disassembly into individual assemblies is required. The metals contained in electric and electronic assemblies can be recovered by means of special separation procedures as well. If the products contain batteries or accumulators, they have to be removed before recycling and furnished to the battery recycling, if possible.

13 Extension and conversion



Modifications exceeding the extent described in these operating instructions are not permitted.

The pilot control valve must particularly not be exchanged or replaced by another one.

Additional components like e.g. throttles, preload or pressure reducing valves must not be integrated into the valve.

Such modifications may only be performed by persons authorized by the manufacturer.

13.1 Optional accessories

Subplates



Information on the subplates is contained in the "Technical data sheet" of the subplates. The assignment of the valves to the "Technical data sheet" of the subplates is contained in table 16.

Table 16: Subplates

Valve type	Technical data sheet
Size 10	RE 45054
Size 16	RE 45056
Size 25	RE 45058
Size 32	RE 45060

Throttle inserts



Details on throttle inserts are available in the operating instructions of the pilot control valve because they can be mounted in channel P of the pilot control valve.

After a conversion of the throttle insert, the coded type designation printed on the name plate of the valve does not specify the current status any more and must thus be corrected.

Thus, we recommend a conversion and the update of the name plate by the Bosch Rexroth Service.

Special tool for the manual override with valve type ..WPH...

Table 17: Special tool

Valve type	Material no.
For all types with manual override	R900024943

Address for ordering accessories and valves

The addresses of our responsible sales companies can be found on the Internet at <http://www.boschrexroth.com> and in section "16.2 Address directory" on page 39.

14 Troubleshooting

14.1 How to proceed for troubleshooting

- ▶ Always work systematically and focused, even when under time pressure. Random and imprudent disassembly and readjustment of settings can, in the worst-case scenario, result in the inability to determine the original cause of the fault.
- ▶ First get a general idea of how your valve works in conjunction with the entire system.
- ▶ Try to find out whether the valve has worked properly in conjunction with the entire system before the troubles occurred first.
- ▶ Try to determine any changes of the entire system in which the valve is integrated:
 - Were there any changes to the valve's operating conditions or operating range?
 - Were there any changes (e.g. refittings) or repair works on the entire system (machine/system, electrics, control) or on the valve? If so: What were they?
 - Was the valve or machine used as intended?
 - How did the malfunction become apparent?
- ▶ Try to get a clear idea of the cause of the fault. Ask the direct (machine) operator, if necessary.

Fault table

The valve is not susceptible to faults as long as the specified operating conditions are complied with, in particular the oil quality.

Troubleshooting | Technical data

Table 18: Fault table

Fault	Possible causes	Remedy
Valve does not switch	No pressure at P	Check and/or restore pressure at port P.
	Spool is jammed due to contamination.	Only with valve type ..WPH..., try to release the spool by actuating the manual override, see section "8.1 Operating the manual override (only with valve types ...WPH...)" on page 27. If the spool cannot be released, remove the valve and replace it by a new valve.
External leakage	Seal damaged	
	- Seal at valve connection surface damaged.	Remove the valve and replace seals.
	- Other leakage	Remove valve and replace it with a new one.

Additional malfunction table for spool position monitoring



The following description applies to the following valve types:
...QM...

Table 19: Fault table for spool position monitoring

Fault	Possible causes	Remedy
No signals from the spool position monitoring	Electrical connection interrupted, no current continuity, cable break	
	- Cable break	Replace connection cable.
	- Connector defective or damaged.	Replace the connector.
	Faulty application	Contact Bosch Rexroth.
	Contaminated spool position monitoring	Clean the spool position monitoring.

Following faults due to pollution, it is - in addition to the repair - essential to check the oil quality and improve it, if necessary, by suitable means such as flushing or the additional installation of filters.

If you could not remedy the occurred fault, please contact one of the addresses you find on the Internet at <http://www.boschrexroth.com> or in section "16.2. Address directory" on page 39.

15 Technical data

For details about the technical data of your valve please refer to the "Technical data sheet".



The assignment of the valves to the Technical data sheets is contained in table 2 on page 6.

16 Appendix

16.1 Project/installation drawings

See "Technical data sheet".



The assignment of the valves to the Technical data sheets is contained in table 2 on page 6.

16.2 Address directory

Please refer to <http://www.boschrexroth.com>. for addresses of foreign subsidiaries.

Contacts for repairs and spare parts

Bosch Rexroth AG
Service Industriehydraulik [Industrial hydraulics]
Bürgermeister-Dr.-Nebel-Straße 8
97816 Lohr am Main
Germany

Phone +49 (93 52) 18-46 66
Fax +49 (93 52) 18-33 63
<http://www.boschrexroth.com/service>

Address for ordering accessories and valves

Headquarters:
Bosch Rexroth AG
Hydraulics
Zum Eisengießer 1
97816 Lohr am Main
Germany

Phone +49 (93 52) 18-0
Fax +49 (93 52) 18-40
or the respectively competent sales organizations.
You will find the addresses on the Internet at:
<http://www.boschrexroth.com>

Rexroth
Bosch Group

Printed in Germany
RE 24851-B/2009-06