

Rexroth
Bosch Group

Axial Piston Variable Motor A6VM

RE 91604/06.12
Replaces: 07.09

1/80

Data sheet

Series 63
Size Nominal pressure
28 to 200 400 bar/450 bar
250 to 1000 350 bar/400 bar
Open and closed circuits

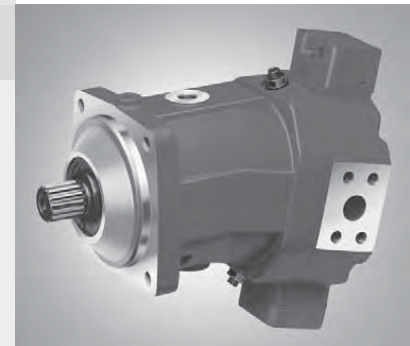

Contents

Ordering code for standard program	2
Technical data	5
HD – Proportional control hydraulic	10
EP – Proportional control electric	14
HZ – Two-point control hydraulic	18
EZ – Two-point control electric	19
HA – Automatic control high-pressure related	21
DA – Automatic control speed-related	27
Electric travel direction valve (for DA, HA.R)	29
Dimensions 28 to 1000	30
Connector for solenoids	70
Flushing and boost pressure valve	71
Counterbalance valve BVD and BVE	73
Swivel angle indicator	77
Speed sensors	78
Installation instructions	79
General instructions	80

Features

- Variable motor with axial tapered piston rotary group of bent-axis design, for hydrostatic drives in open and closed circuits
- For use in mobile and stationary applications
- The wide control range enables the variable motor to satisfy the requirement for high speed and high torque.
- The displacement can be infinitely changed from $V_{g \max}$ to $V_{g \min} = 0$.
- The output speed is dependent on the flow of the pump and the displacement of the motor.
- The output torque increases with the pressure differential between the high-pressure and low-pressure side and with increasing displacement.
- Wide control range with hydrostatic transmissions
- Wide selection of control devices
- Cost savings through elimination of gear shifts and possibility of using smaller pumps
- Compact, robust motor with long service life
- High power density
- Good starting characteristics
- Small swing torque

Technical data

Hydraulic fluid

Before starting project planning, please refer to our data sheets RE 90220 (mineral oil), RE 90221 (environmentally acceptable hydraulic fluids), RE 90222 (HFD hydraulic fluids) and RE 90223 (HFA, HFB, HFC hydraulic fluids) for detailed information regarding the choice of hydraulic fluid and application conditions.

The variable motor A6VM is not suitable for operation with HFA hydraulic fluid. If HFB, HFC, or HFD or environmentally acceptable hydraulic fluids are used, the limitations regarding technical data or other seals must be observed.

Selection diagram

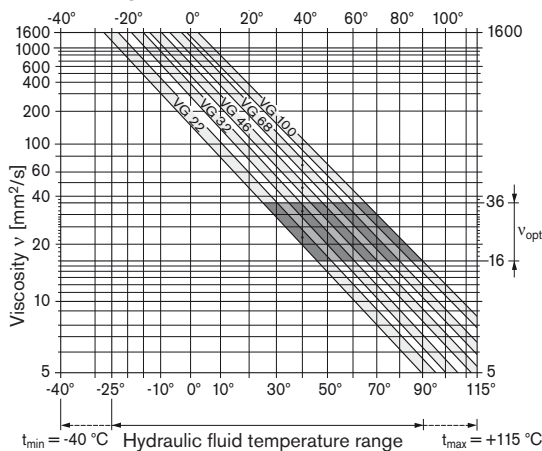

Details regarding the choice of hydraulic fluid

The correct choice of hydraulic fluid requires knowledge of the operating temperature in relation to the ambient temperature: in a closed circuit, the circuit temperature, in an open circuit, the reservoir temperature.

The hydraulic fluid should be chosen so that the operating viscosity in the operating temperature range is within the optimum range (v_{opt} see shaded area of the selection diagram). We recommended that the higher viscosity class be selected in each case.

Example: At an ambient temperature of X °C, an operating temperature of 60 °C is set in the circuit. In the optimum viscosity range ($v_{opt,1}$ shaded area), this corresponds to the viscosity classes VG 46 or VG 68; to be selected: VG 68.

Note

The case drain temperature, which is affected by pressure and speed, can be higher than the circuit temperature or reservoir temperature. At no point of the component may the temperature be higher than 115 °C. The temperature difference specified below is to be taken into account when determining the viscosity in the bearing.

If the above conditions cannot be maintained due to extreme operating parameters, we recommend flushing the case at port U or using a flushing and boost pressure valve (see pages 71 and 72).

Viscosity and temperature of hydraulic fluid

	Viscosity [mm ² /s]	Temperature	Comment
Transport and storage at ambient temperature		$T_{min} \geq -50$ °C $T_{opt} = +5$ °C to +20 °C	factory preservation: up to 12 months with standard, up to 24 months with long-term
(Cold) start-up ¹⁾	$v_{max} = 1600$	$T_{St} \geq -40$ °C	$t \leq 3$ min, without load ($p \leq 50$ bar), $n \leq 1000$ rpm (sizes 28 to 200), $n \leq 0.25 \cdot n_{nom}$ (sizes 250 to 1000)
Permissible temperature difference		$\Delta T \leq 25$ K	between axial piston unit and hydraulic fluid
Warm-up phase	$v < 1600$ to 400	$T = -40$ °C to -25 °C	At $p \leq 0.7 \cdot p_{nom}$, $n \leq 0.5 \cdot n_{nom}$ and $t \leq 15$ min
Operating phase			
Temperature difference		$\Delta T =$ approx. 12 K	between hydraulic fluid in the bearing and at port T. The bearing temperature can be reduced by flushing via port U.
Maximum temperature		115 °C 103 °C	in the bearing measured at port T
Continuous operation	$v = 400$ to 10 $v_{opt} = 36$ to 16	$T = -25$ °C to +90 °C	measured at port T, no restriction within the permissible data
Short-term operation ²⁾	$v_{min} \geq 7$	$T_{max} = +103$ °C	measured at port T, $t < 3$ min, $p < 0.3 \cdot p_{nom}$
FKM shaft seal ¹⁾		$T \leq +115$ °C	see page 6

1) At temperatures below -25 °C, an NBR shaft seal is required (permissible temperature range: -40 °C to +90 °C).

2) Sizes 250 to 1000, please contact us.

Technical data

Filtration of the hydraulic fluid

Finer filtration improves the cleanliness level of the hydraulic fluid, which increases the service life of the axial piston unit.

To ensure the functional reliability of the axial piston unit, a gravimetric analysis of the hydraulic fluid is necessary to determine the amount of solid contaminant and to determine the cleanliness level according to ISO 4406. A cleanliness level of at least 20/18/15 is to be maintained.

At very high hydraulic fluid temperatures (90 °C to maximum 115 °C), a cleanliness level of at least 19/17/14 according to ISO 4406 is necessary.

If the above classes cannot be achieved, please contact us.

Shaft seal

Permissible pressure loading

The service life of the shaft seal is influenced by the speed of the axial piston unit and the case drain pressure (case pressure). The mean differential pressure of 2 bar between the case and the ambient pressure may not be enduringly exceeded at normal operating temperature. For a higher differential pressure at reduced speed, see diagram. Momentary pressure spikes ($t < 0.1$ s) of up to 10 bar are permitted. The service life of the shaft seal decreases with an increase in the frequency of pressure spikes.

The case pressure must be equal to or higher than the ambient pressure.

Sizes 28 to 200

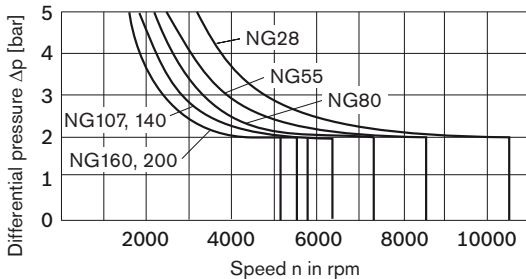

Sizes 250 to 1000

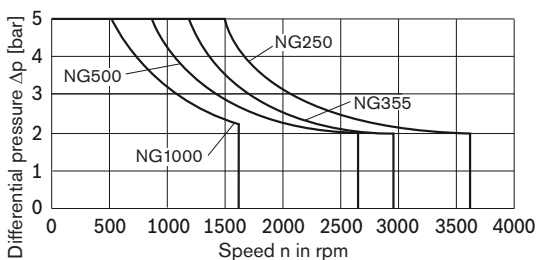

The values are valid for an ambient pressure $p_{abs} = 1$ bar.

Temperature range

The FKM shaft seal may be used for case drain temperatures from -25 °C to +115 °C.

Note

For application cases below -25 °C, an NBR shaft seal is required (permissible temperature range: -40 °C to +90 °C). State NBR shaft seal in plain text when ordering. Please contact us.

Influence of case pressure on beginning of control

An increase in case pressure affects the beginning of control of the variable motor when using the following control options:

HD, HA.T (sizes 28 to 200) _____ increase
HD, EP, HA, HA.T (sizes 250 to 1000) _____ increase
DA _____ decrease

With the following controls, an increase in the case pressure has no influence on the beginning of control:

EP, HA, HA.R, HA.U (sizes 28 to 200)

The factory settings for the beginning of control are made at $p_{abs} = 2$ bar (sizes 28 to 200) and $p_{abs} = 1$ bar (sizes 250 to 1000) case pressure.

Direction of flow

Direction of rotation, viewed on drive shaft

clockwise	counter-clockwise
A to B	B to A

Long-life bearings

Sizes 250 to 1000

For long service life and use with HF hydraulic fluids. Identical external dimensions as motor with standard bearings. Subsequent conversion to long-life bearings is possible. Bearings and case flushing via port U is recommended.

Flushing flow (recommended)

NG	250	355	500	1000
$q_{v \text{ flush}}$ (L/min)	10	16	16	16

Technical data

Operating pressure range

(operating with mineral oil)

Pressure at service line port A or B

Sizes 28 to 200

Nominal pressure p_{nom} _____ 400 bar absolute

Maximum pressure p_{max} _____ 450 bar absolute

Single operating period _____ 10 s

Total operating period at _____ 300 h

Sizes 250 to 1000

Nominal pressure p_{nom} _____ 350 bar absolute

Maximum pressure p_{max} _____ 400 bar absolute

Single operating period _____ 10 s

Total operating period _____ 300 h

Minimum pressure (high-pressure side) _____ 25 bar absolute

Summation pressure (pressure A + pressure B) p_{Su} _____ 700 bar

Rate of pressure change $R_{A max}$

with integrated pressure-relief valve _____ 9000 bar/s

without pressure-relief valve _____ 16000 bar/s

Minimum pressure – pump mode (inlet)

To prevent damage to the axial piston motor in pump operating mode (change of high-pressure side with unchanged direction of rotation, e. g. when braking), a minimum pressure must be guaranteed at the service line port (inlet). This minimum pressure is dependent on the speed and displacement of the axial piston unit (see characteristic curve below).

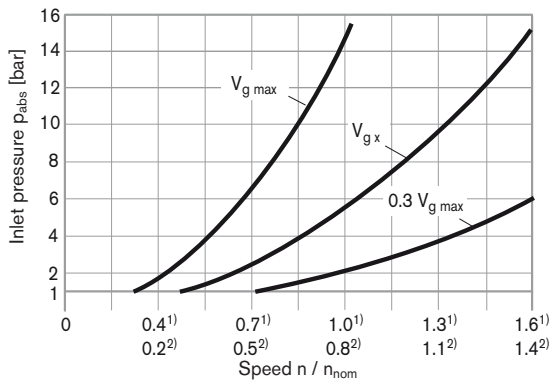

¹⁾ For sizes 28 to 200

²⁾ For sizes 250 to 1000

This diagram is valid only for the optimum viscosity range from $\nu_{opt} = 36$ to $16 \text{ mm}^2/\text{s}$.

Please contact us if the above conditions cannot be satisfied.

Note

Values for other hydraulic fluids, please contact us.

Definition

Nominal pressure p_{nom}

The nominal pressure corresponds to the maximum design pressure.

Maximum pressure p_{max}

The maximum pressure corresponds to the maximum operating pressure within the single operating period. The sum of the single operating periods must not exceed the total operating period.

Minimum pressure (high-pressure side)

Minimum pressure at the high-pressure side (A or B) which is required in order to prevent damage to the axial piston unit.

Summation pressure p_{Su}

The summation pressure is the sum of the pressures at both service line ports (A and B).

Rate of pressure change R_A

Maximum permissible rate of pressure rise and reduction during a pressure change over the entire pressure range.

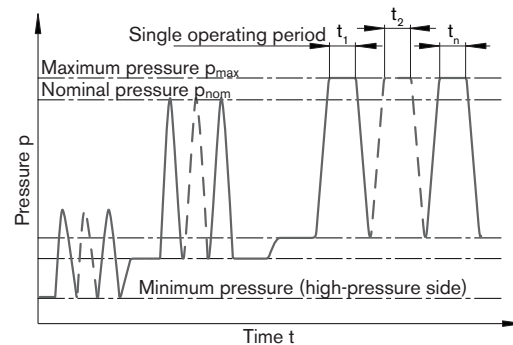
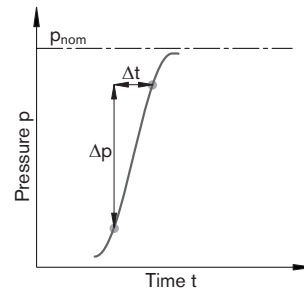

Total operating period = $t_1 + t_2 + \dots + t_n$

Technical data

Table of values (theoretical values, without efficiency and tolerances; values rounded)

Size	NG	28	55	80	107	140	160	200	250	355	500	1000
Displacement geometric ¹⁾ , per revolution	$V_{g \max}$ cm ³	28.1	54.8	80	107	140	160	200	250	355	500	1000
	$V_{g \min}$ cm ³	0	0	0	0	0	0	0	0	0	0	0
	$V_{g x}$ cm ³	18	35	51	68	88	61	76	188	270	377	762
Speed maximum ²⁾ (while adhering to the maximum permissible input flow)												
at $V_{g \max}$	n_{nom} rpm	5550	4450	3900	3550	3250	3100	2900	2700	2240	2000	1600
at $V_g < V_{g x}$ (see diagram below)	n_{max} rpm	8750	7000	6150	5600	5150	4900	4600	3600	2950	2650	1600
at $V_{g 0}$	n_{max} rpm	10450	8350	7350	6300	5750	5500	5100	3600	2950	2650	1600
Input flow ³⁾												
at n_{nom} and $V_{g \max}$	$q_{v \max}$ L/min	156	244	312	380	455	496	580	675	795	1000	1600
Torque ⁴⁾												
at $V_{g \max}$ and $\Delta p = 400$ bar	T Nm	179	349	509	681	891	1019	1273	-	-	-	-
at $V_{g \max}$ and $\Delta p = 350$ bar	T Nm	157	305	446	596	778	891	1114	1391	1978	2785	5571
Rotary stiffness												
$V_{g \max}$ to $V_g/2$	c_{min} KNm/rad	6	10	16	21	34	35	44	60	75	115	281
$V_g/2$ to 0 (interpolated)	c_{max} KNm/rad	18	32	48	65	93	105	130	181	262	391	820
Moment of inertia for rotary group	J_{GR} kgm ²	0.0014	0.0042	0.008	0.0127	0.0207	0.0253	0.0353	0.061	0.102	0.178	0.55
Maximum angular acceleration	α rad/s ²	47000	31500	24000	19000	11000	11000	11000	10000	8300	5500	4000
Case volume	V L	0.5	0.75	1.2	1.5	1.8	2.4	2.7	3.0	5.0	7.0	16.0
Mass (approx.)	m kg	16	26	34	47	60	64	80	100	170	210	430

- The minimum and maximum displacement are infinitely adjustable, see ordering code, page 3.
(standard setting for sizes 250 to 1000 if not specified in the order: $V_{g \min} = 0.2 \cdot V_{g \max}$, $V_{g \max} = V_{g \max}$).
- The values are valid:
 - for the optimum viscosity range from $v_{\text{opt}} = 36$ to 16 mm²/s
 - with hydraulic fluid based on mineral oils
- Restriction of input flow with counterbalance valve, see page 74
- Torque without radial force, with radial force see page 9

Note

Operation above the maximum values or below the minimum values may result in a loss of function, a reduced service life or in the destruction of the axial piston unit. Other permissible limit values, with respect to speed variation, reduced angular acceleration as a function of the frequency and the permissible startup angular acceleration (lower than the maximum angular acceleration) can be found in data sheet 90261.

Permissible displacement in relation to speed

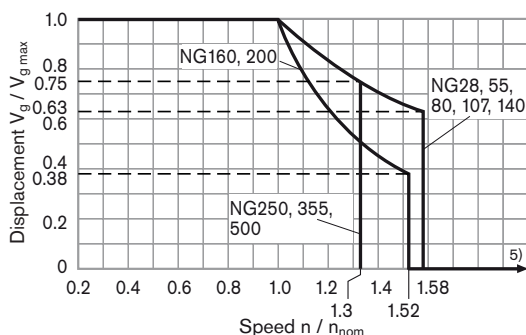

- Values in this range on request

Determining the operating characteristics

$$\text{Input flow } q_v = \frac{V_g \cdot n}{1000 \cdot \eta_v} \quad [\text{L/min}]$$

$$\text{Speed } n = \frac{q_v \cdot 1000 \cdot \eta_v}{V_g} \quad [\text{min}^{-1}]$$

$$\text{Torque } T = \frac{V_g \cdot \Delta p \cdot \eta_{mh}}{20 \cdot \pi} \quad [\text{Nm}]$$

$$\text{Power } P = \frac{2 \pi \cdot T \cdot n}{60000} = \frac{q_v \cdot \Delta p \cdot \eta_t}{600} \quad [\text{kW}]$$

V_g = Displacement per revolution in cm³

Δp = Differential pressure in bar

n = Speed in rpm



η_v = Volumetric efficiency



η_{mh} = Mechanical-hydraulic efficiency

η_t = Total efficiency ($\eta_t = \eta_v \cdot \eta_{mh}$)

Technical data

Permissible radial and axial forces of the drive shafts

Size	NG		28	28	55	55	80	80	107	107	140	
Drive shaft	ø	mm	30	25	35	30	40	35	45	40	45	
Maximum radial force ¹⁾ at distance a (from shaft collar)		$F_{q \max}$	N	4838	6436	8069	7581	10283	10266	12215	13758	15982
		a	mm	17.5	14	20	17.5	22.5	20	25	22.5	25
with permissible torque		T_{\max}	Nm	179	179	349	281	509	444	681	681	891
△ Permissible pressure Δp at $V_{g \max}$		$p_{\text{nom perm.}}$	bar	400	400	400	322	400	349	400	400	400
Maximum axial force ²⁾		$+F_{ax \max}$	N	315	315	500	500	710	710	900	900	1030
		$-F_{ax \max}$	N	0	0	0	0	0	0	0	0	0
Permissible axial force per bar operating pressure		$F_{ax \text{ perm./bar}}$	N/bar	4.6	4.6	7.5	7.5	9.6	9.6	11.3	11.3	13.3

Size	NG		160	160	200	250	355	500	1000	
Drive shaft	ø	mm	50	45	50	50	60	70	90	
Maximum radial force ¹⁾ at distance a (from shaft collar)		$F_{q \max}$	N	16435	18278	20532	1200 ³⁾	1500 ³⁾	1900 ³⁾	2600 ³⁾
		a	mm	27.5	25	27.5	41	52.5	52.5	67.5
with permissible torque		T_{\max}	Nm	1019	1019	1273	4)	4)	4)	4)
△ Permissible pressure Δp at $V_{g \max}$		$p_{\text{nom perm.}}$	bar	400	400	400	4)	4)	4)	4)
Maximum axial force ²⁾		$+F_{ax \max}$	N	1120	1120	1250	1200	1500	1900	2600
		$-F_{ax \max}$	N	0	0	0	0	0	0	0
Permissible axial force per bar operating pressure		$F_{ax \text{ perm./bar}}$	N/bar	15.1	15.1	17.0	4)	4)	4)	4)

1) With intermittent operation.

2) Maximum permissible axial force during standstill or when the axial piston unit is operating in non-pressurized condition.

3) When at a standstill or when axial piston unit operating in non-pressurized conditions. Higher forces are permissible when under pressure, please contact us.

4) Please contact us.

Note

Influence of the direction of the permissible axial force:

+ $F_{ax \max}$ = Increase in service life of bearings

- $F_{ax \max}$ = Reduction in service life of bearings (avoid)

Effect of radial force F_q on the service life of bearings

By selecting a suitable direction of radial force F_q , the load on the bearings, caused by the internal rotary group forces can be reduced, thus optimizing the service life of the bearings. Recommended position of mating gear is dependent on direction of rotation. Examples:

Toothed gear drive

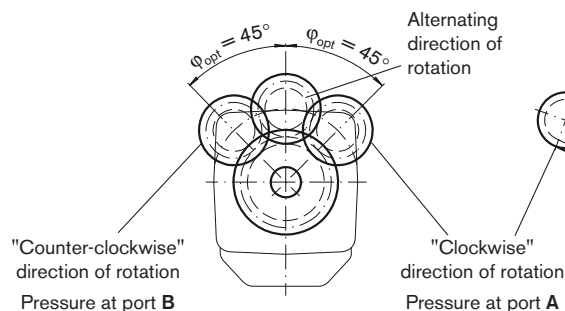

V-belt drive

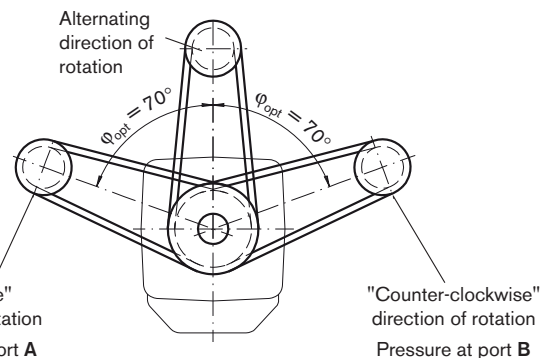

HD – Proportional control hydraulic

The proportional hydraulic control provides infinite setting of the displacement, proportional to the pilot pressure applied to port X.

- Beginning of control at $V_{g \max}$ (maximum torque, minimum speed at minimum pilot pressure)
- End of control at $V_{g \min}$ (minimum torque, maximum permissible speed at maximum pilot pressure)

Note

- Maximum permissible pilot pressure: $p_{St} = 100$ bar
- The control oil is internally taken out of the high-pressure side of the motor (A or B). For reliable control, an operating pressure of at least 30 bar is required in A (B). If a control operation is performed at an operating pressure < 30 bar, an auxiliary pressure of at least 30 bar must be applied at port G via an external check valve. For lower pressures, please contact us.
Please note that pressures up to 450 bar can occur at port G.
- Please state the desired beginning of control in plain text when ordering, e. g.: beginning of control at 10 bar.
- The beginning of control and the HD characteristic are influenced by the case pressure. An increase in case pressure causes an increase in the beginning of control (see page 6) and thus a parallel shift of the characteristic.
- A leakage flow of maximum 0.3 L/min can escape at port X due to internal leakage (operating pressure $>$ pilot pressure). The control is to be suitably configured to avoid an independent build-up of pilot pressure.

HD1

Pilot pressure increase $\Delta p_{St} = 10$ bar

A pilot pressure increase of 10 bar at port X results in a decrease in displacement from $V_{g \max}$ to 0 cm^3 (sizes 28 to 200) or from $V_{g \max}$ to $0.2 V_{g \max}$ (sizes 250 to 1000).

Beginning of control, setting range _____ 2 to 20 bar

Standard setting:

Beginning of control at 3 bar (end of control at 13 bar)

HD1 characteristic

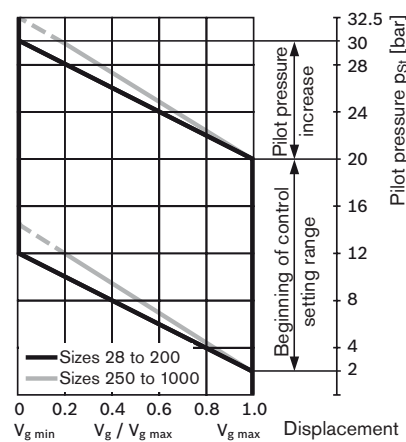

HD2

Pilot pressure increase $\Delta p_{St} = 25$ bar

A pilot pressure increase of 25 bar at port X results in a decrease in displacement from $V_{g \max}$ to 0 cm^3 (sizes 28 to 200) or from $V_{g \max}$ to $0.2 V_{g \max}$ (sizes 250 to 1000).

Beginning of control, setting range _____ 5 to 35 bar

Standard setting:

Beginning of control at 10 bar (end of control at 35 bar)

HD2 characteristic

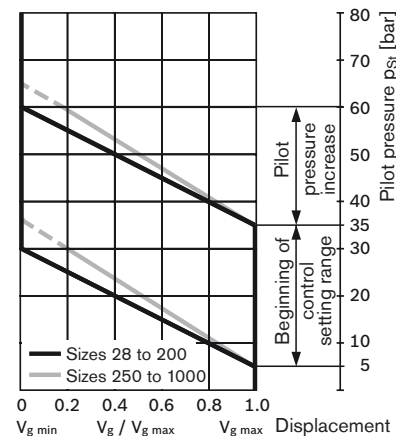

HD3

Pilot pressure increase $\Delta p_{St} = 35$ bar

(sizes 250 to 1000)

A pilot pressure increase of 35 bar at port X results in a decrease in displacement from $V_{g \max}$ to $0.2 V_{g \max}$.

Beginning of control, setting range _____ 7 to 50 bar

Standard setting:

Beginning of control at 10 bar (end of control at 45 bar)

HDR3 characteristic

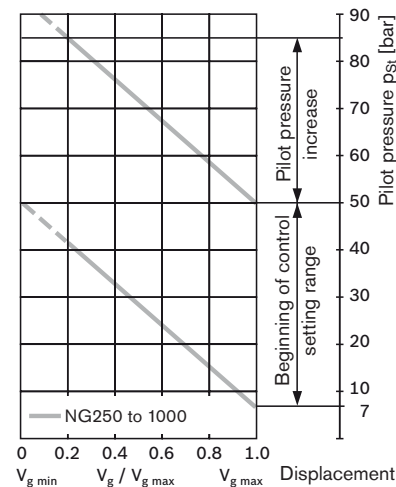

HD – Proportional control hydraulic

Schematic HD1, HD2, HD3
Sizes 28 to 200

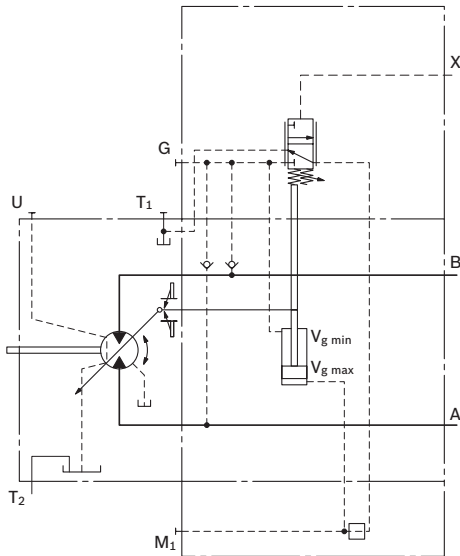

Schematic HD1, HD2, HD3
Sizes 250 to 1000

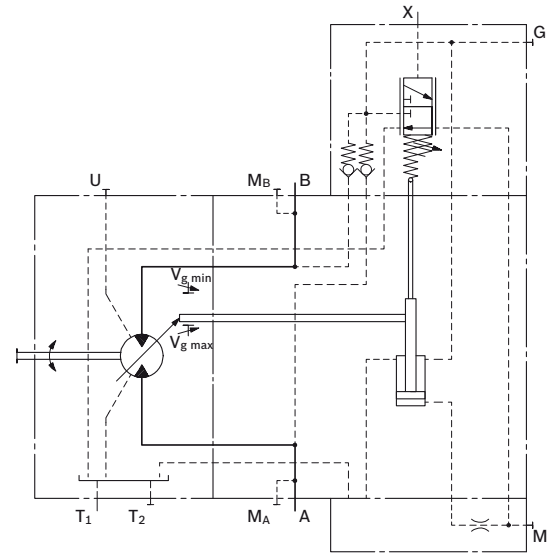

Note

The spring return feature in the control part is not a safety device

The control part can stick in an undefined position by internal contamination (contaminated hydraulic fluid, abrasion or residual contamination from system components). As a result, the control will no longer respond correctly to the operator's commands.

Check whether the application on your machine requires additional safety measures, in order to bring the driven actuator into a controlled and safe position (immediate stop). If necessary, make sure these are properly implemented.

HD – Proportional control hydraulic

HD.D Pressure control, fixed setting

The pressure control overrides the HD control function. If the load torque or a reduction in motor swivel angle causes the system pressure to reach the setpoint of the pressure control, the motor will swivel towards a larger displacement.

The increase in the displacement and the resulting reduction in pressure cause the control deviation to decrease. With the increase in displacement the motor develops more torque, while the pressure remains constant.

Setting range of the pressure control valve
 Sizes 28 to 200 _____ 80 to 400 bar
 Sizes 250 to 1000 _____ 80 to 350 bar

Schematic HD.D Sizes 28 to 200

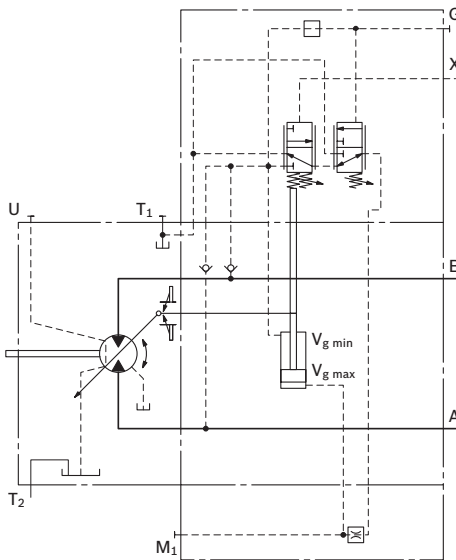

Schematic HD.D Sizes 250 to 1000

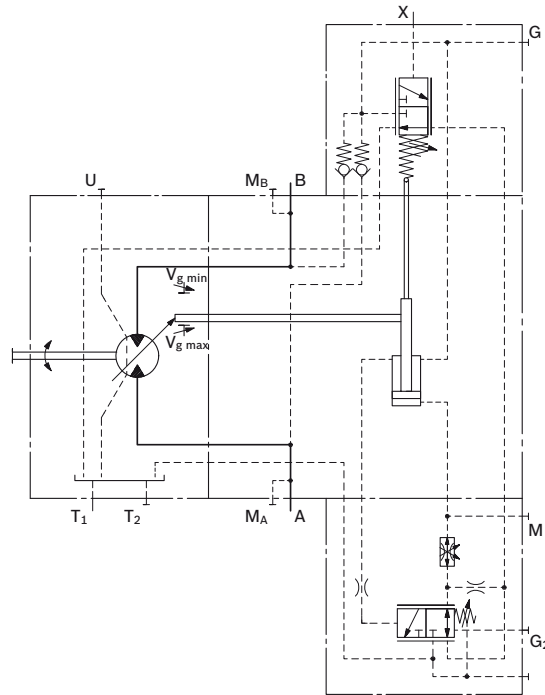

HD – Proportional control hydraulic

HD.E Pressure control, hydraulic override, two-point

Sizes 28 to 200

The pressure control setting can be overridden by applying an external pilot pressure at port G_2 , realizing a 2nd pressure setting.

Required pilot pressure at port G_2 :
 $p_{St} = 20$ to 50 bar

Please state the 2nd pressure setting in plain text when ordering.

Schematic HD.E

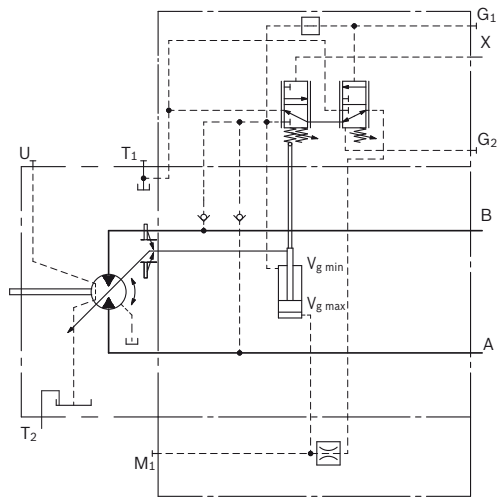

Sizes 250 to 1000 (HD.D)

Pressure control with 2nd pressure setting for HD.D provided as standard (see page 12).

The pressure control setting can be overridden by applying an external pilot pressure at port G_2 , realizing a 2nd pressure setting.

Required pilot pressure at port G_2 :
 $p_{St} \geq 100$ bar

Please state the 2nd pressure setting in plain text when ordering.

HD.G Pressure control, remote control

Sizes 250 to 1000

When the set pressure value is reached, the remote control pressure control continually regulates the motor to maximum displacement $V_{g \max}$. A pressure-relief valve (not included in the delivery contents), which is located separately from the motor and which is connected to port X_3 , assumes the task of controlling the internal pressure cut-off valve.

So long as the target pressure value has not been reached, pressure is evenly applied to the valve from both sides in addition to the force of the spring, and the valve remains closed. The target pressure value is between 80 bar and 350 bar. When the target pressure value is reached at the separate pressure-relief valve, this will open, relieving the pressure on the spring side to the reservoir. The internal control valve switches and the motor swivels to maximum displacement $V_{g \max}$. The differential pressure at the control valve is set as standard to 25 bar. As a separate pressure-relief valve, we recommend:

DBD 6 (hydraulic) as per RE 25402

The maximum line length should not exceed 2 m.

Schematic HD.G

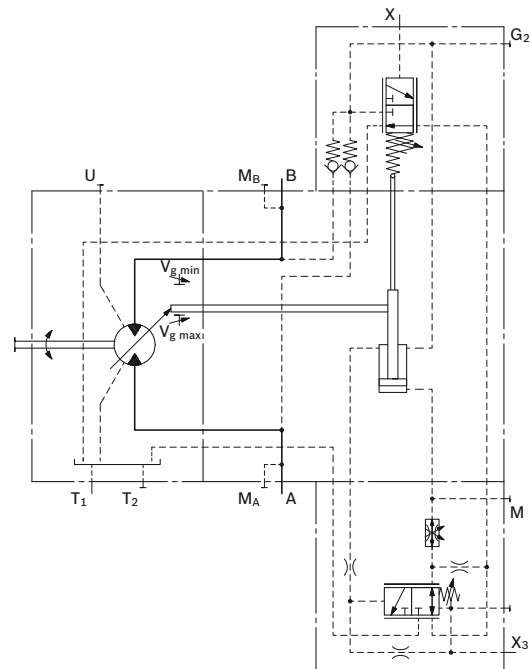

EP – Proportional control electric

The proportional electric control provides infinite setting of the displacement, proportional to the control current applied to the solenoid (sizes 28 to 200) or proportional valve (sizes 250 to 1000).

For sizes 250 to 1000, the pilot oil supply at port P requires an external pressure of $p_{\min} = 30$ bar ($p_{\max} = 100$ bar).

- Beginning of control at $V_{g \max}$ (maximum torque, minimum speed at minimum control current)
- End of control at $V_{g \min}$ (minimum torque, maximum permissible speed at maximum control current)

Characteristic

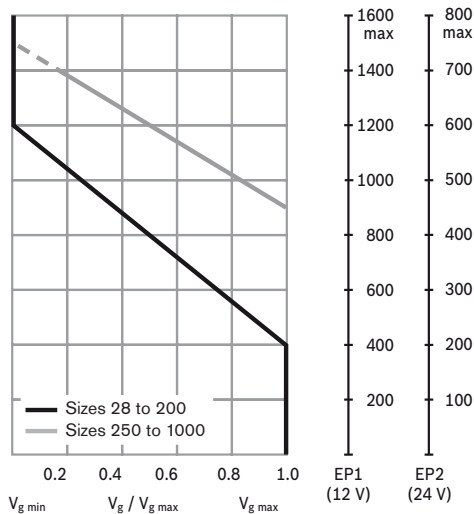

Note

The control oil is internally taken out of the high-pressure side of the motor (A or B). For reliable control, an operating pressure of at least 30 bar is required in A (B). If a control operation is performed at an operating pressure < 30 bar, an auxiliary pressure of at least 30 bar must be applied at port G via an external check valve. For lower pressures, please contact us.

Please note that pressures up to 450 bar can occur at port G.

The following only needs to be noted for sizes 250 to 1000:

- The beginning of control and the EP characteristic are influenced by the case pressure. An increase in case pressure causes an increase in the beginning of control (see page 6) and thus a parallel shift of the characteristic.

Technical data, solenoid

Sizes 28 to 200

	EP1	EP2
Voltage	12 V (± 20 %)	24 V (± 20 %)
Control current		
Beginning of control	400 mA	200 mA
End of control	1200 mA	600 mA
Limiting current	1.54 A	0.77 A
Nominal resistance (at 20 °C)	5.5 Ω	22.7 Ω
Dither frequency	100 Hz	100 Hz
Duty cycle	100 %	100 %

Type of protection see connector design page 70

The following electronic controllers and amplifiers are available for controlling the proportional solenoids:

- BODAS controller RC
 - Series 20 _____ RE 95200
 - Series 21 _____ RE 95201
 - Series 22 _____ RE 95202
 - Series 30 _____ RE 95203, RE 95204
 and application software
- Analog amplifier RA _____ RE 95230
- Electric amplifier VT 2000, series 5X (see RE 29904) (for stationary application)

Further information can also be found on the Internet at www.boschrexroth.com/mobile-electronics

Technical data, proportional valve

Sizes 250 to 1000

	EP1	EP2
Voltage	12 V (± 20 %)	24 V (± 20 %)
Beginning of control at $V_{g \max}$	900 mA	450 mA
End of control at $V_{g \min}$	1400 mA	700 mA
Limiting current	2.2 A	1.0 A
Nominal resistance (at 20 °C)	2.4 Ω	12 Ω
Duty cycle	100 %	100 %

Type of protection see connector design page 70

See also proportional pressure-reducing valve DRE 4K (RE 29181).

Note

The spring return feature in the control part is not a safety device

The control part can stick in an undefined position by internal contamination (contaminated hydraulic fluid, abrasion or residual contamination from system components). As a result, the control will no longer respond correctly to the operator's commands.

Check whether the application on your machine requires additional safety measures, in order to bring the driven actuator into a controlled and safe position (immediate stop). If necessary, make sure these are properly implemented.

EP – Proportional control electric

Schematic EP1, EP2
 Sizes 28 to 200

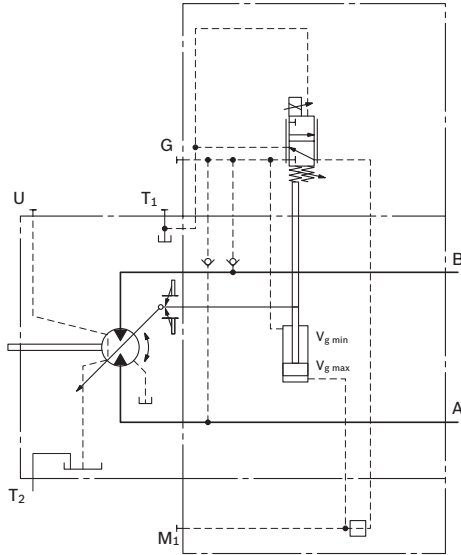

Schematic EP1, EP2
 Sizes 250 to 1000

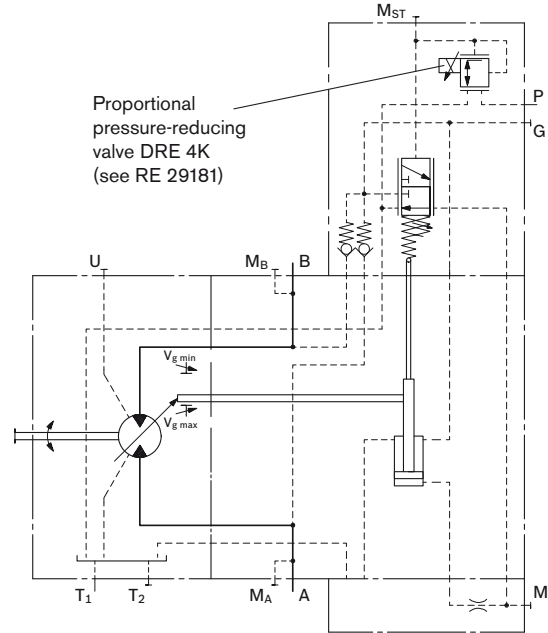

EP – Proportional control electric

EP.D Pressure control, fixed setting

The pressure control overrides the EP control function. If the load torque or a reduction in motor swivel angle causes the system pressure to reach the setpoint of the pressure control, the motor will swivel towards a larger displacement.

The increase in the displacement and the resulting reduction in pressure cause the control deviation to decrease. With the increase in displacement the motor develops more torque, while the pressure remains constant.

Setting range of the pressure control valve:

Sizes 28 to 200 _____ 80 to 400 bar
Sizes 250 to 1000 _____ 80 to 350 bar

Schematic EP.D Sizes 28 to 200

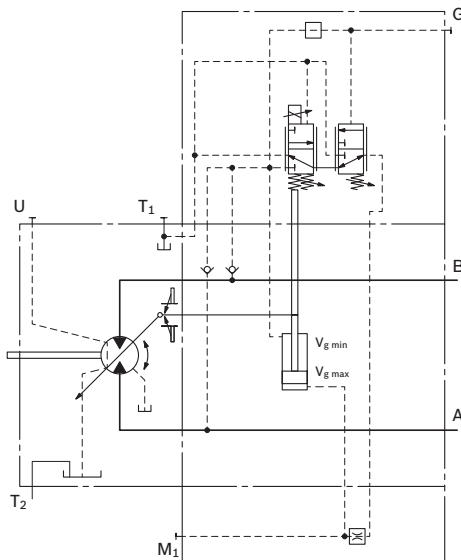

Schematic EP.D Sizes 250 to 1000

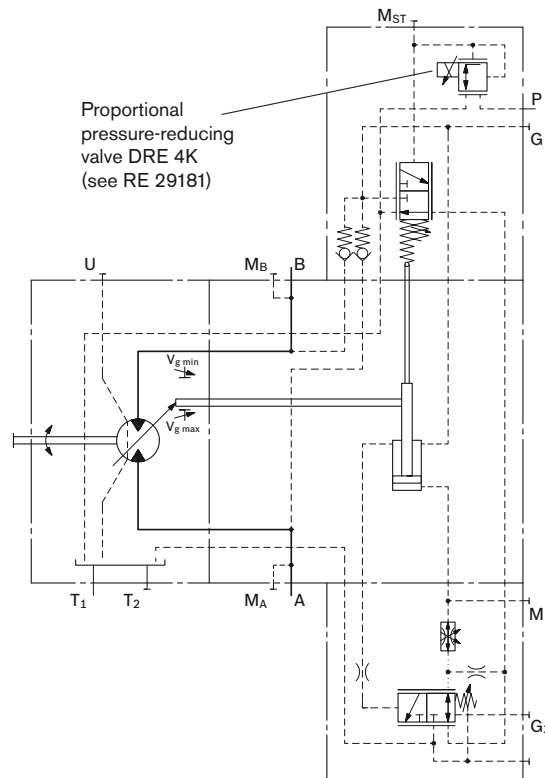

EP – Proportional control electric

EP.E Pressure control, hydraulic override, two-point

Sizes 28 to 200

The pressure control setting can be overridden by applying an external pilot pressure at port G_2 , realizing a 2nd pressure setting.

Required pilot pressure at port G_2 :
 $p_{St} = 20$ to 50 bar

Please state the 2nd pressure setting in plain text when ordering.

Schematic EP.E

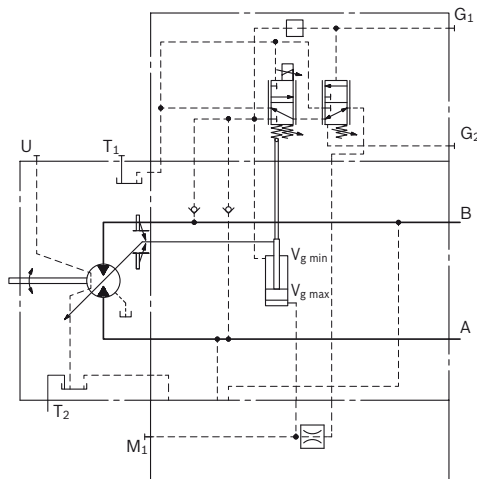

Sizes 250 to 1000 (EP.D)

Pressure control with 2nd pressure setting for EP.D provided as standard (see on page 16).

The pressure control setting can be overridden by applying an external pilot pressure at port G_2 , realizing a 2nd pressure setting.

Required pilot pressure at port G_2 :
 $p_{St} \geq 100$ bar

Please state the 2nd pressure setting in plain text when ordering.

EP.G Pressure control, remote control

Sizes 250 to 1000

When the set pressure value is reached, the remote control pressure control continually regulates the motor to maximum displacement $V_{g \max}$. A pressure-relief valve (not included in the delivery contents), which is located separately from the motor and which is connected to port X_3 , assumes the task of controlling the internal pressure cut-off valve.

So long as the target pressure value has not been reached, pressure is evenly applied to the valve from both sides in addition to the force of the spring, and the valve remains closed. The target pressure value is between 80 bar and 350 bar. When the target pressure value is reached at the separate pressure-relief valve, this will open, relieving the pressure on the spring side to the reservoir. The internal control valve switches and the motor swivels to maximum displacement $V_{g \max}$. The differential pressure at the control valve is set as standard to 25 bar. As a separate pressure-relief valve, we recommend:

DBD 6 (hydraulic) as per RE 25402

The maximum line length should not exceed 2 m.

Schematic EP.G

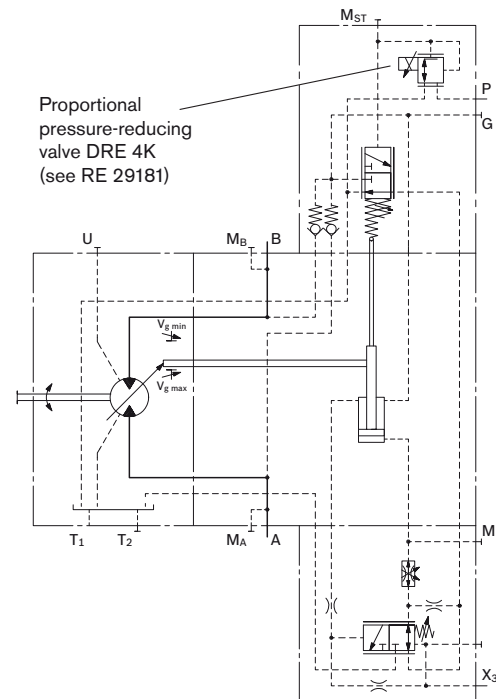

HZ – Two-point control hydraulic

The two-point hydraulic control allows the displacement to be set to either $V_{g \min}$ or $V_{g \max}$ by switching the pilot pressure at port X on or off.

- Position at $V_{g \max}$ (without pilot pressure, maximum torque, minimum speed)
- Position at $V_{g \min}$ (with pilot pressure > 10 bar activated, minimum torque, maximum permissible speed)

Characteristic HZ

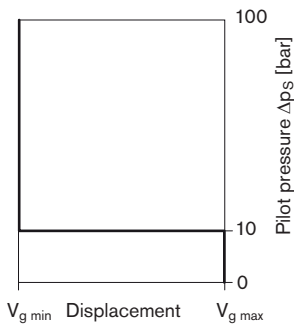

Note

- Maximum permissible pilot pressure: 100 bar
- The control oil is internally taken out of the high-pressure side of the motor (A or B). For reliable control, an operating pressure of at least 30 bar is required in A (B). If a control operation is performed at an operating pressure < 30 bar, an auxiliary pressure of at least 30 bar must be applied at port G via an external check valve. For lower pressures, please contact us. Please note that pressures up to 450 bar can occur at port G.
- A leakage flow of maximum 0.3 L/min is present at port X (operating pressure > pilot pressure). To avoid a build-up of pilot pressure, pressure is to be relieved from port X to the reservoir.

Schematic HZ3

Sizes 55 to 107

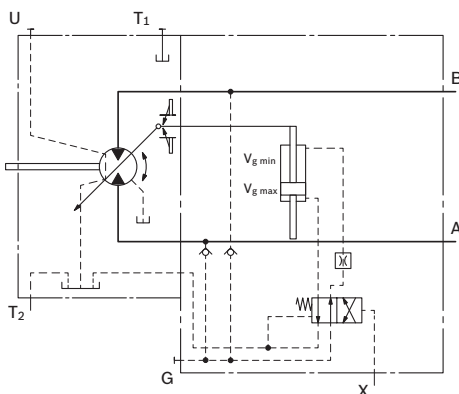

Schematic HZ1

Sizes 28, 140, 160, 200

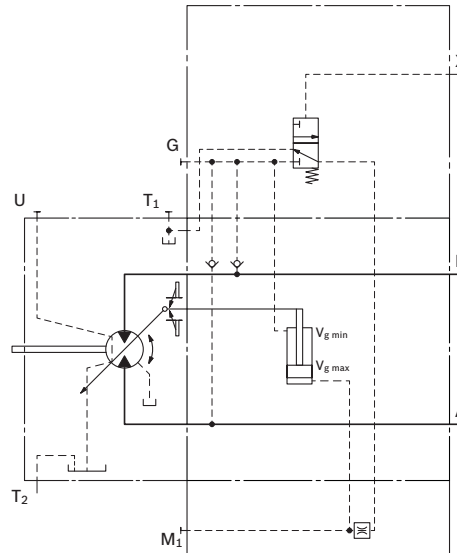

Schematic HZ

Sizes 250 to 1000

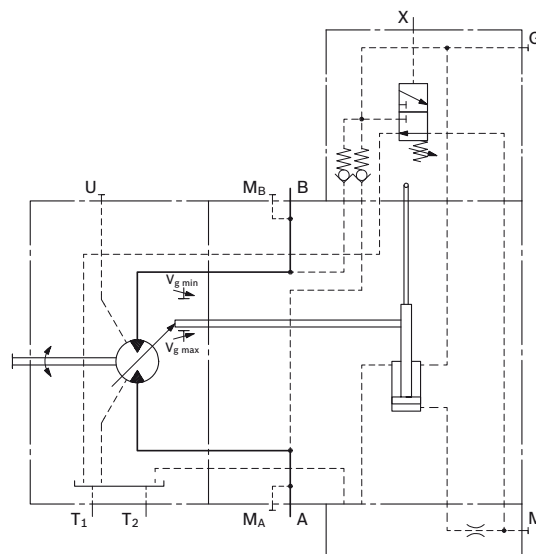

EZ – Two-point control electric

The two-point electric control with switching solenoid (sizes 28 to 200) or control valve (sizes 250 to 1000) allows the displacement to be set to either $V_{g \min}$ or $V_{g \max}$ by switching the electric current at the switching solenoid or control valve on or off.

Note

The control oil is internally taken out of the high-pressure side of the motor (A or B). For reliable control, an operating pressure of at least 30 bar is required in A (B). If a control operation is performed at an operating pressure < 30 bar, an auxiliary pressure of at least 30 bar must be applied at port G via an external check valve. For lower pressures, please contact us.

Please note that pressures up to 450 bar can occur at port G.

Technical data, solenoid with Ø37

Sizes 28, 140, 160, 200

	EZ1	EZ2
Voltage	12 V ($\pm 20\%$)	24 V ($\pm 20\%$)
Displacement $V_{g \max}$	de-energized	de-energized
Displacement $V_{g \min}$	energized	energized
Nominal resistance (at 20 °C)	5.5 Ω	21.7 Ω
Nominal power	26.2 W	26.5 W
Minimum required current	1.32 A	0.67 A
Duty cycle	100 %	100 %
Type of protection	see connector design page 70	

Technical data, solenoid with Ø45

Sizes 55 to 107

	EZ3	EZ4
Voltage	12 V ($\pm 20\%$)	24 V ($\pm 20\%$)
Displacement $V_{g \max}$	de-energized	de-energized
Displacement $V_{g \min}$	energized	energized
Nominal resistance (at 20 °C)	4.8 Ω	19.2 Ω
Nominal power	30 W	30W
Minimum required current	1.5 A	0.75 A
Duty cycle	100 %	100 %
Type of protection	see connector design page 70	

Technical data, control valve

Sizes 250 to 1000

	EZ1	EZ2
Voltage	12 V ($\pm 20\%$)	24 V ($\pm 20\%$)
Displacement $V_{g \max}$	de-energized	de-energized
Displacement $V_{g \min}$	energized	energized
Nominal resistance (at 20 °C)	6 Ω	23 Ω
Nominal power	26 W	26W
Minimum required current	2 A	1.04 A
Duty cycle	100 %	100 %
Type of protection	see connector design page 70	

Schematic EZ1, EZ2

Sizes 28, 140, 160, 200

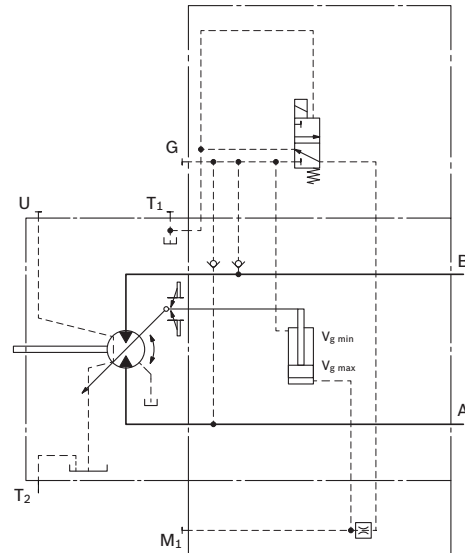

Schematic EZ3, EZ4

Sizes 55 to 107

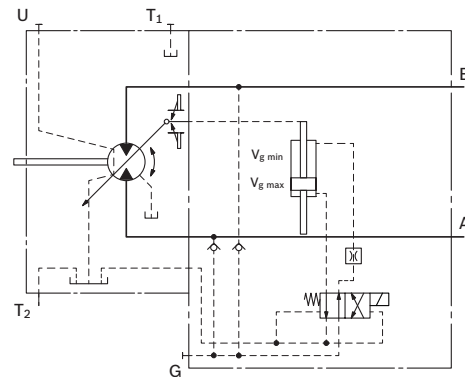

EZ – Two-point control electric

Schematic EZ1, EZ2
Sizes 250 to 1000

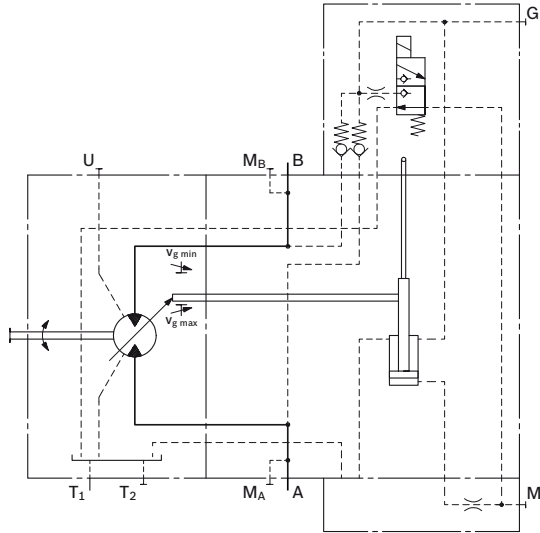

HA – Automatic control high-pressure related

The automatic high-pressure related control adjusts the displacement automatically depending on the operating pressure.

The displacement of the A6VM motor with HA control is $V_{g \min}$ (maximum speed and minimum torque). The control unit measures internally the operating pressure at A or B (no control line required) and upon reaching the beginning of control, the controller swivels the motor from $V_{g \min}$ to $V_{g \max}$ with increase of pressure. The displacement is modulated between $V_{g \min}$ and $V_{g \max}$, thereby depending on load conditions.

- Beginning of control at $V_{g \min}$ (minimum torque, maximum speed)
- End of control at $V_{g \max}$ (maximum torque, minimum speed)

Note

- For safety reasons, winch drives are not permissible with beginning of control at $V_{g \min}$ (standard for HA).
- The control oil is internally taken out of the high-pressure side of the motor (A or B). For reliable control, an operating pressure of at least 30 bar is required in A (B). If a control operation is performed at an operating pressure < 30 bar, an auxiliary pressure of at least 30 bar must be applied at port G via an external check valve. For lower pressures, please contact us.
Please note that pressures up to 450 bar can occur at port G.
- The beginning of control and the HA characteristic are influenced by the case pressure. An increase in case pressure causes an increase in the beginning of control (see page 7) and thus a parallel shift of the characteristic. Only for HA1T (sizes 28 to 200) and HA1, HA2, HA.T, (sizes 250 to 1000).
- A leakage flow of maximum 0.3 L/min is present at port X (operating pressure > pilot pressure). To avoid a build-up of pilot pressure, pressure is to be relieved from port X to the reservoir.
Only for control HA.T.

HA – Automatic control high-pressure related

HA1 With minimum pressure increase

An operating pressure increase of $\Delta p \leq$ approx. 10 bar results in an increase in displacement from 0 cm³ to $V_{g \max}$ (sizes 28 to 200) or from 0.2 $V_{g \max}$ to $V_{g \max}$ (sizes 250 to 1000).

Beginning of control, setting range

Sizes 28 to 200 _____ 80 to 350 bar
 Sizes 250 to 1000 _____ 80 to 340 bar

Please state the desired beginning of control in plain text when ordering, e. g.: beginning of control at 300 bar.

Characteristic HA1

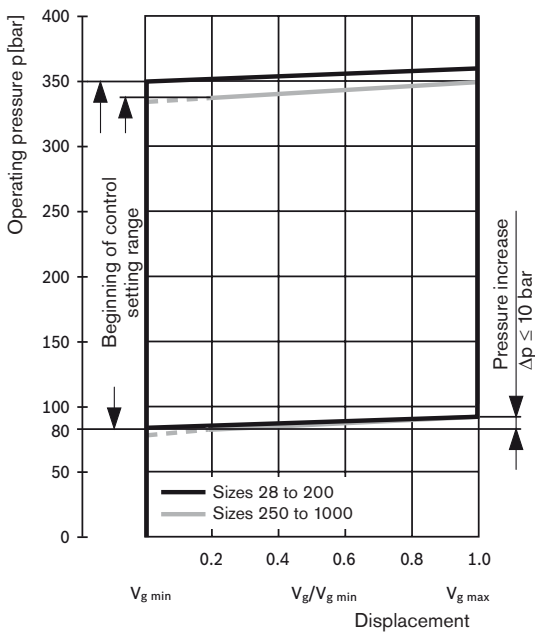

Schematic HA1 Sizes 28 to 200

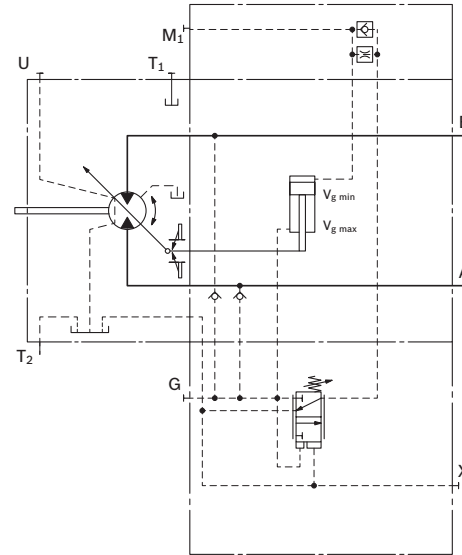

Sizes 250 to 1000

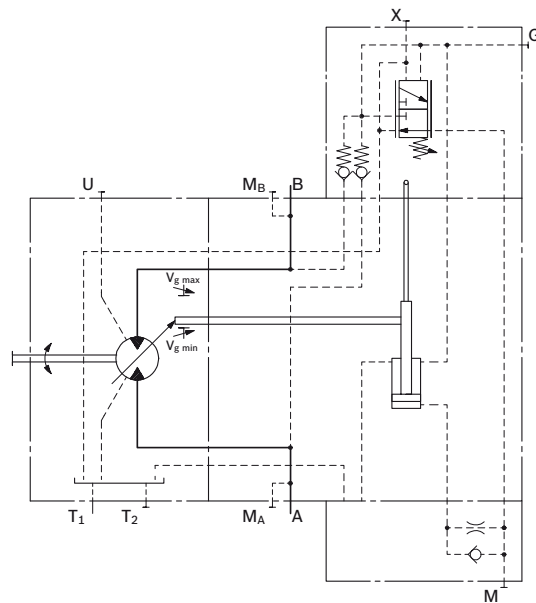

HA – Automatic high-pressure related control

HA2 With pressure increase

An operating pressure increase of $\Delta p = \text{approx. } 100 \text{ bar}$ results in an increase in displacement from 0 cm^3 to $V_{g \text{ max}}$ (sizes 28 to 200) or from $0.2 V_{g \text{ max}}$ to $V_{g \text{ max}}$ (sizes 250 to 1000).

Beginning of control, setting range

Sizes 28 to 200 _____ 80 to 350 bar

Sizes 250 to 1000 _____ 80 to 250 bar

Please state the desired beginning of control in plain text when ordering, e. g.: beginning of control at 200 bar.

Characteristic HA2

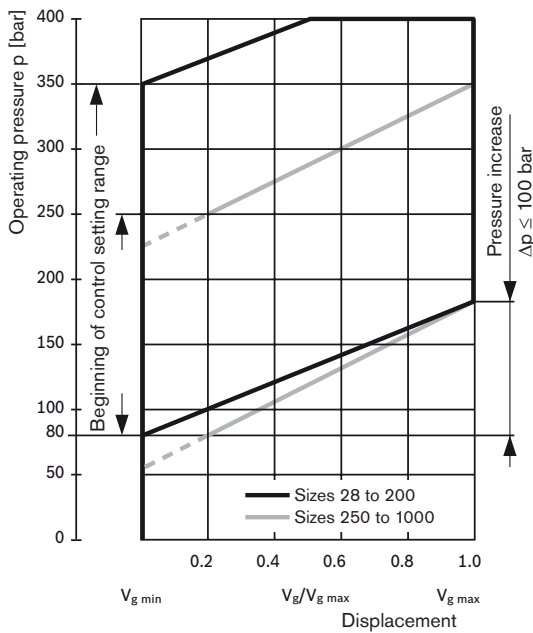

Schematic HA2 Sizes 28 to 200

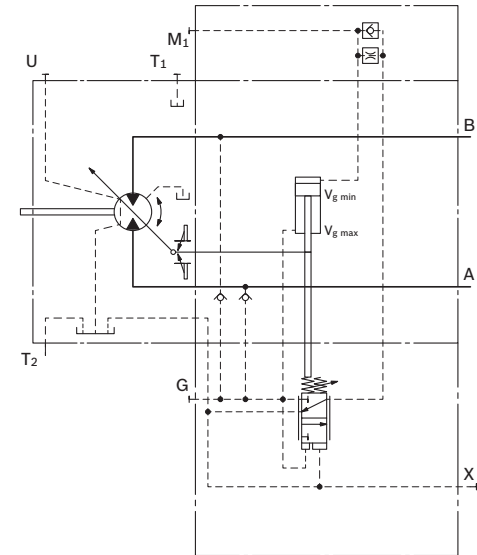

Sizes 250 to 1000

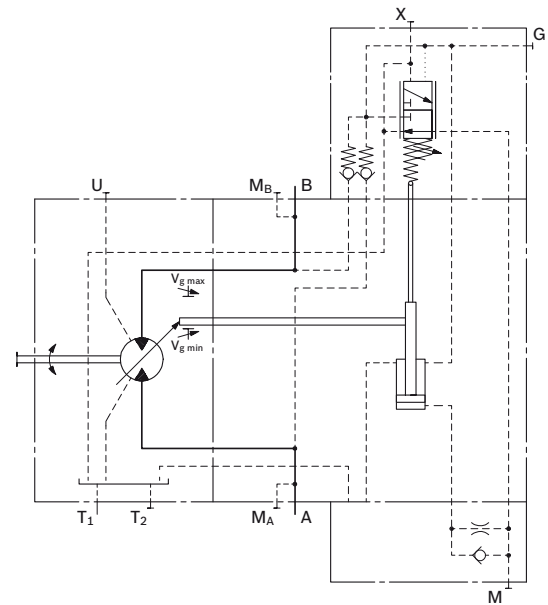

HA – Automatic control high-pressure related

HA.T Override hydraulic remote control, proportional

With the HA.T3 control, the beginning of control can be influenced by applying a pilot pressure to port X.

For each 1 bar of pilot pressure increase, the beginning of control is reduced by 17 bar (sizes 28 to 200) or 8 bar (sizes 250 to 1000).

Example (sizes 28 to 200):

Beginning of control setting	300 bar	300 bar
Pilot pressure at port X	0 bar	10 bar
Beginning of control at	300 bar	130 bar

Note

Maximum permissible pilot pressure 100 bar.

Schematic HA1.T

Sizes 28 to 200

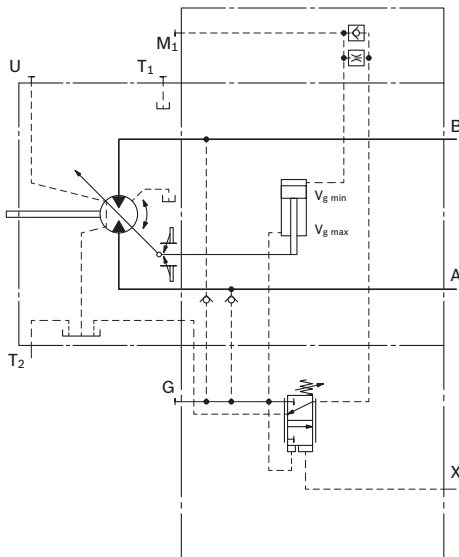

Schematic HA1.T

Sizes 250 to 1000

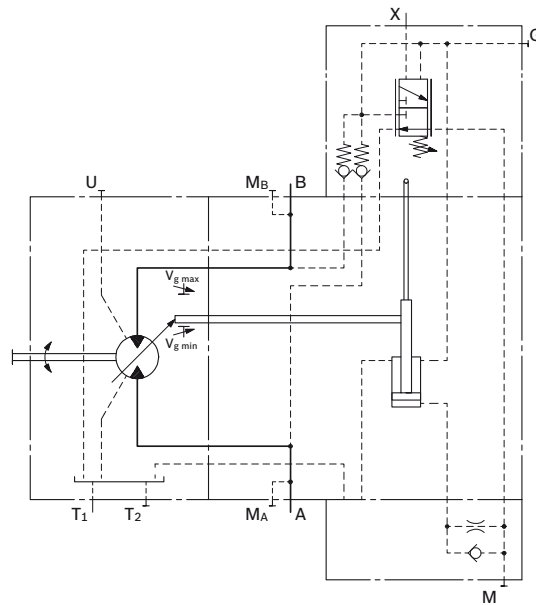

Schematic HA2.T

Sizes 28 to 200

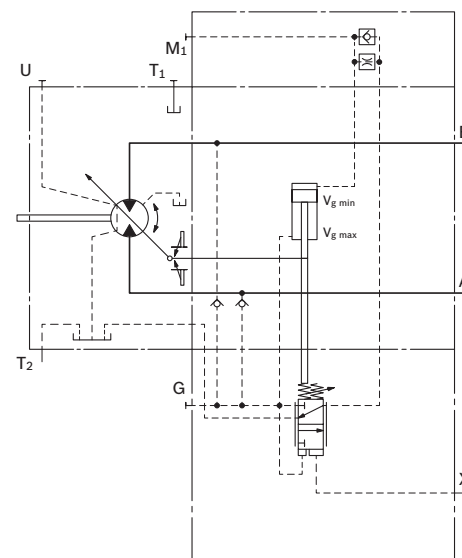

HA – Automatic control high-pressure related

HA.U1, HA.U2 Override electric two-point

Sizes 28 to 200

With the HA.U1 or HA.U2 control, the beginning of control can be overridden by an electric signal to a switching solenoid. When the override solenoid is energized, the variable motor swivels to maximum swivel angle, without intermediate position. The beginning of control is adjustable between 80 and 300 bar (specify required setting in plain text when ordering).

Technical data, solenoid with Ø45

	U1	U2
Voltage	12 V (±20 %)	24 V (±20 %)
No override	de-energized	de-energized
Displacement $V_{g \max}$	energized	energized
Nominal resistance (at 20 °C)	4.8 Ω	19.2 Ω
Nominal power	30 W	30 W
Minimum required current	1.5 A	0.75 A
Duty cycle	100 %	100 %
Type of protection see connector design page 70		

Schematic HA2U1, HA2U2

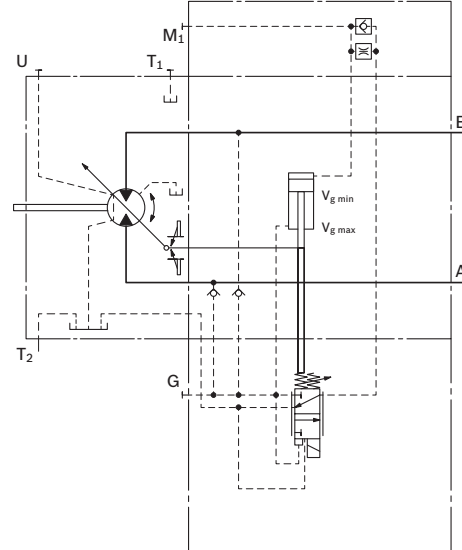

Schematic HA1U1, HA1U2

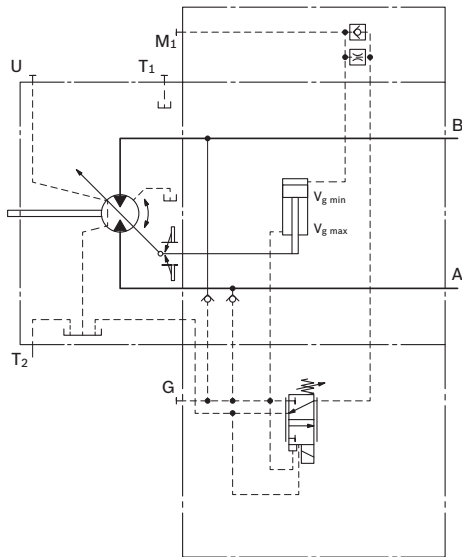

HA – Automatic control high-pressure related

HA.R1, HA.R2
Override electric,
travel direction valve electric (see page 29)

Sizes 28 to 200

With the HA.R1 or HA.R2 control, the beginning of control can be overridden by an electric signal to switching solenoid b. When the override solenoid b is energized, the variable motor swivels to maximum swivel angle, without intermediate position.

The travel direction valve ensures that the preselected pressure side of the hydraulic motor (A or B) is always connected to the HA control, and thus determines the swivel angle, even if the high-pressure side changes (e. g. -travel drive during a downhill operation). This thereby prevents undesired jerky deceleration and/or braking characteristics.

Depending on the direction of rotation (direction of travel), the travel direction valve is actuated through the pressure spring or the switching solenoid a (see page 29 for further details).

Technical data, solenoid a with Ø37
(travel direction valve)

	R1	R2
Voltage	12 V (±20 %)	24 V (±20 %)
No override	de-energized	de-energized
Direction of rotation	Operating pressure in	
ccw	B	energized
energized		energized
cw	A	de-energized
de-energized		de-energized
Nominal resistance (at 20 °C)	5.5 Ω	21.7 Ω
Nominal power	26.2 W	26.5 W
Minimum required current	1.32 A	0.67 A
Duty cycle	100 %	100 %
Type of protection	see connector design page 70	

Technical data, solenoid b with Ø45
(electric override)

	R1	R2
Voltage	12 V (±20 %)	24 V (±20 %)
No override	de-energized	de-energized
Displacement $V_{g,max}$	energized	energized
Nominal resistance (at 20 °C)	4.8 Ω	19.2 Ω
Nominal power	30 W	30 W
Minimum required current	1.5 A	0.75 A
Duty cycle	100 %	100 %
Type of protection	see connector design page 70	

Schematic HA1R1, HA1R2

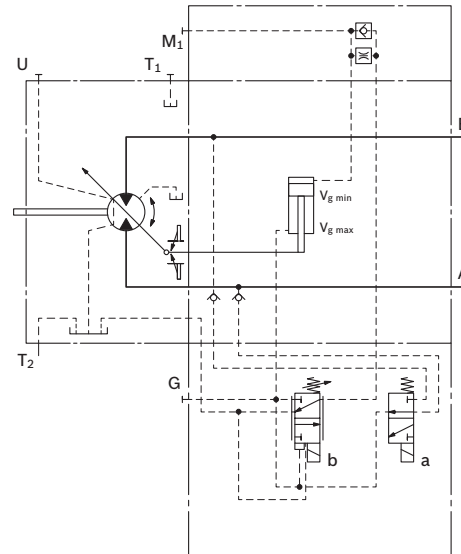

Schematic HA2R1, HA2R2

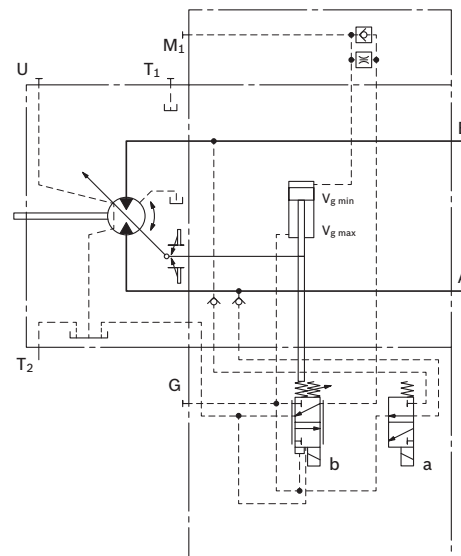

DA – Automatic control speed-related

The variable motor A6VM with automatic speed-related control is intended for use in hydrostatic travel drives in combination with the variable pump A4VG with DA control.

A drive-speed-related pilot pressure signal is generated by the A4VG variable pump, and that signal, together with the operating pressure, regulates the swivel angle of the hydraulic motor.

Increasing pump speed, i.e. increasing pilot pressure, causes the motor to swivel to a smaller displacement (lower torque, higher speed), depending on the operating pressure.

If the operating pressure exceeds the pressure setpoint set on the controller, the variable motor swivels to a larger displacement (higher torque, lower speed).

Pressure ratio p_{S1}/p_{HD} : 3/100, 5/100, 8/100

DA closed loop control is only suitable for certain types of drive systems and requires review of the engine and vehicle parameters to ensure that the motor is used correctly and that machine operation is safe and efficient. We recommend that all DA applications be reviewed by a Bosch Rexroth application engineer.

Detailed information is available from our sales department and on the Internet at www.boschrexroth.com/da-control.

Note

The beginning of control and the DA characteristic are influenced by case pressure. An increase in case pressure causes a decrease in the beginning of control (see page 6) and thus a parallel shift of the characteristic.

DA, DA1, DA4 Hydraulic travel direction valve

Dependent on the direction of rotation (travel direction), the travel direction valve is switched by using pilot pressures connections X₁ or X₂.

Direction of rotation	Operating pressure in	Pilot pressure in
cw	A	X ₁
ccw	B	X ₂

Schematic DA1, DA4

Sizes 28 to 200

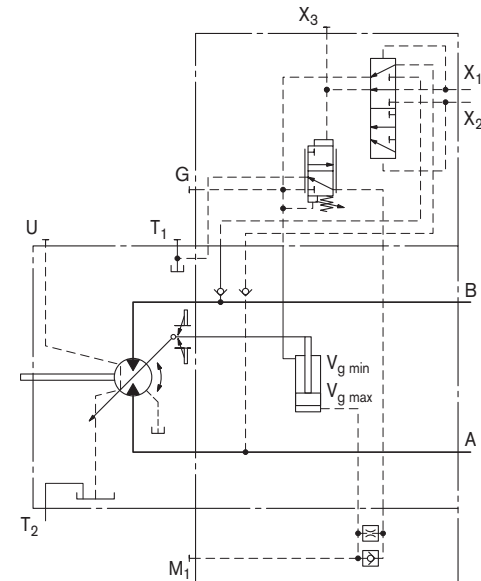

Schematic DA

Sizes 250 to 1000

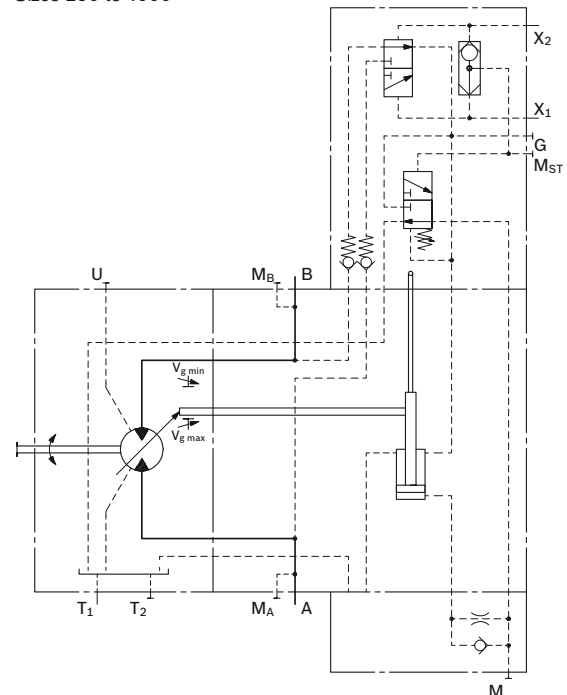

DA – Automatic control speed-related

DA2, DA3, DA5, DA6 Electric travel direction valve + electric $V_{g \max}$ -circuit

The travel direction valve is either spring offset or switched by energizing switching solenoid a, depending on the direction of rotation (travel direction).

When the switching solenoid b is energized, the DA control is overridden and the motor swivels to maximum displacement (high torque, lower speed) (electric $V_{g \max}$ -circuit).

Technical data, solenoid a with Ø37 (travel direction valve)

	DA2, DA5	DA3, DA6
Voltage	12 V ($\pm 20\%$)	24 V ($\pm 20\%$)
Direction of rotation	Operating pressure in	
ccw	B	de-energized
cw	A	energized
Nominal resistance (at 20 °C)	5.5 Ω	21.7 Ω
Nominal power	26.2 W	26.5 W
Minimum required current	1.32 A	0.67 A
Duty cycle	100 %	100 %
Type of protection see connector design page 70		

Technical data, solenoid b with Ø37 (electric override)

	DA2, DA5	DA3, DA6
Voltage	12 V ($\pm 20\%$)	24 V ($\pm 20\%$)
No override	de-energized	de-energized
Displacement $V_{g \max}$	energized	energized
Nominal resistance (at 20 °C)	5.5 Ω	21.7 Ω
Nominal power	26.2 W	26.5 W
Minimum required current	1.32 A	0.67 A
Duty cycle	100 %	100 %
Type of protection see connector design page 70		

Schematic DA2, DA3, DA5, DA6
Sizes 28 to 200

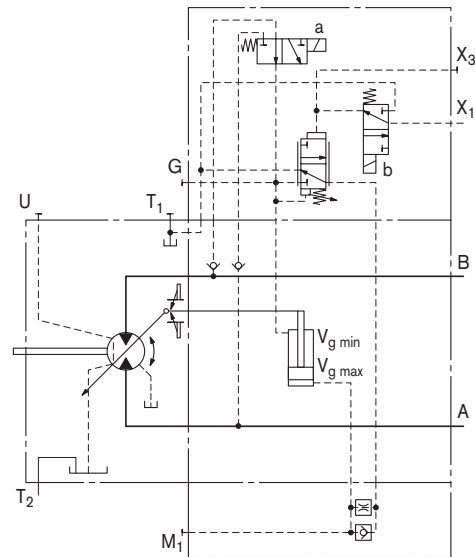

Electric travel direction valve (for DA, HA.R)

Application in travel drives in closed circuits. The travel direction valve of the motor is actuated by an electric signal that also switches the swivel direction of the travel drive pump (e. g. A4VG with DA control valve).

If the pump in the closed circuit is switched to the neutral position or into reverse, the vehicle may experience jerky deceleration or braking, depending on the vehicle's mass and current travel speed.

When the travel direction valve of the pump (e. g. 4/3-directional valve of the DA-control) is switched to

- the neutral position, the electric circuitry causes the previous signal on the travel direction valve on the motor to be retained.
- reversing, the electric circuitry causes the travel direction valve on the motor to switch to the other travel direction following a time delay (approx. 0.8 s) with respect to the pump.

As a result, jerky deceleration or braking is prevented in both cases.

Schematic – electric travel direction valve

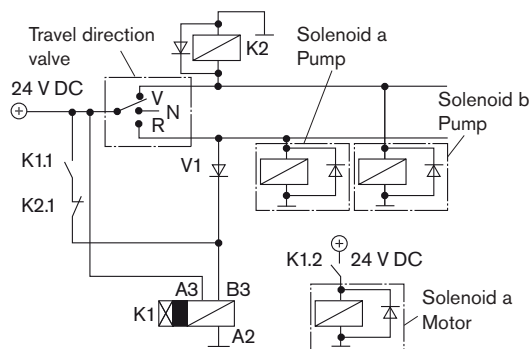

Note

The shown diodes and relays are not included in the delivery of the motor.

DA2, DA3, DA5, DA6 control (see page 28)

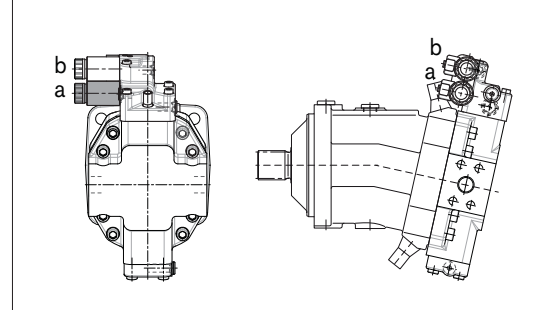

HA1R., HA2R. control (see page 26)

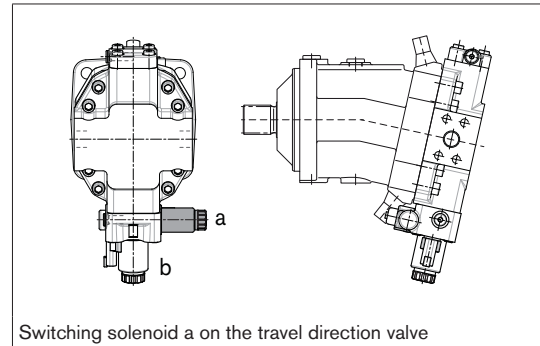

Dimensions size 28

Before finalizing your design, request a binding installation drawing. Dimensions in mm.

EP1, EP2 – Proportional control electric

Port plate 02 – SAE flange ports A and B at side, opposite

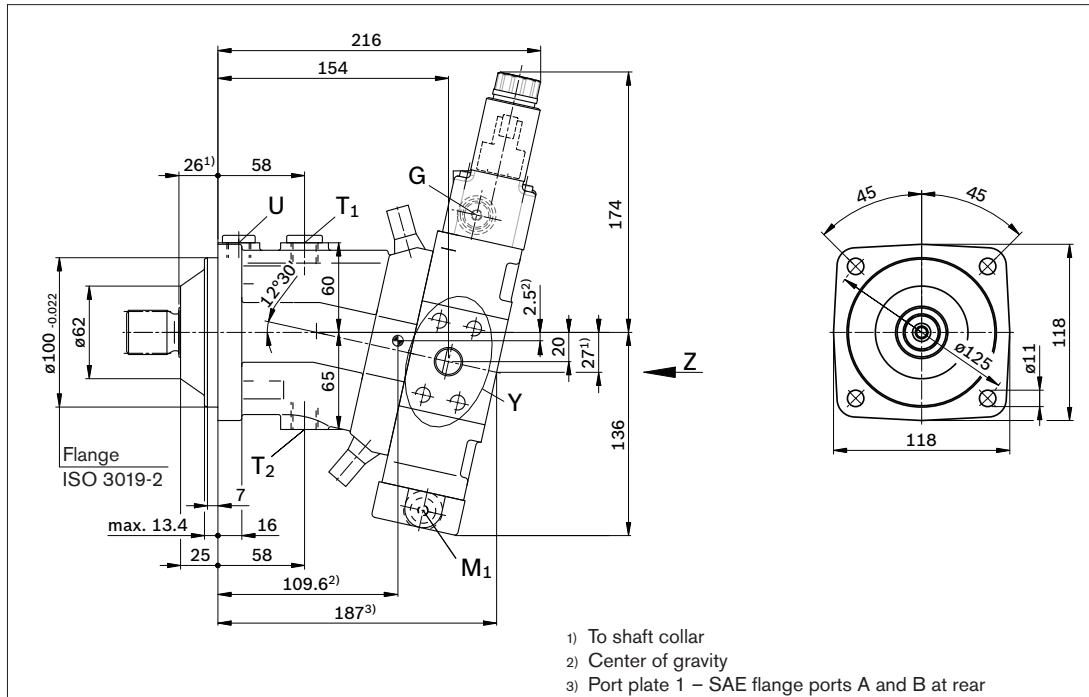

Drive shafts

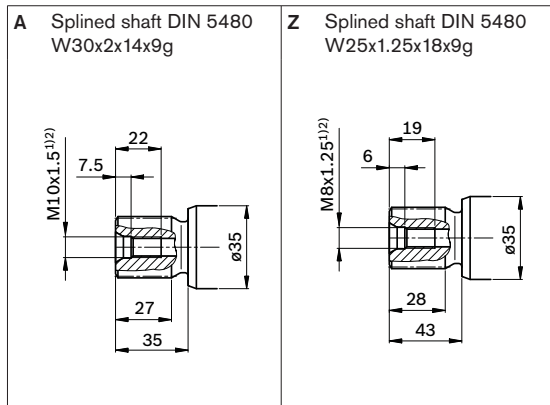

Service line port (detail Y)

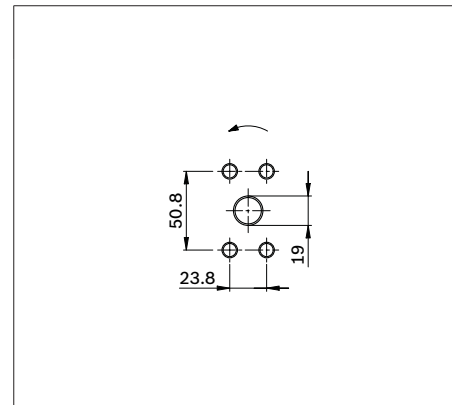

- 1) Observe the general instructions on page 80 for the maximum tightening torques.
- 2) Center bore according to DIN 332 (thread according to DIN 13)

Dimensions size 28

Before finalizing your design, request a binding installation drawing. Dimensions in mm.

Location of the service line ports on the port plates (view Z)

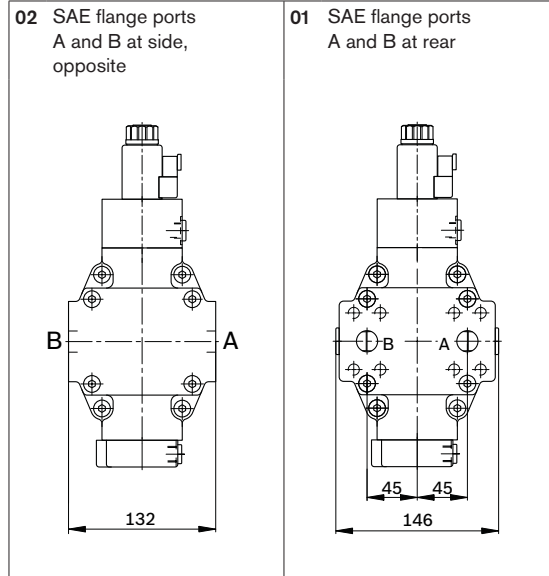

Ports

Designation	Port for	Standard	Size ¹⁾	Maximum pressure [bar] ²⁾	State ⁶⁾
A, B	Service line Fastening thread A/B	SAE J518 ³⁾ DIN 13	3/4 in M10 x 1.5; 17 deep	450	O
T ₁	Drain line	DIN 3852 ⁵⁾	M18 x 1.5; 12 deep	3	X ⁴⁾
T ₂	Drain line	DIN 3852 ⁵⁾	M18 x 1.5; 12 deep	3	O ⁴⁾
G	Synchronous control	DIN 3852 ⁵⁾	M14 x 1.5; 12 deep	450	X
G ₂	2nd pressure setting (HD,E, EPE)	DIN 3852 ⁵⁾	M14 x 1.5; 12 deep	100	X
U	Bearing flushing	DIN 3852 ⁵⁾	M16 x 1.5; 12 deep	3	X
X	Pilot signal (HD, HZ, HA1T/HA2T)	DIN 3852 ⁵⁾	M14 x 1.5; 12 deep	100	O
X	Pilot signal (HA1 and HA2)	DIN 3852 ⁵⁾	M14 x 1.5; 12 deep	3	X
X ₁ , X ₂	Pilot signal (DA1, DA4)	DIN 2353-CL	8B-ST	40	O
X ₁	Pilot signal (DA2, DA3, DA5, DA6)	DIN 3852 ⁵⁾	M14 x 1.5; 12 deep	40	O
X ₃	Pilot signal (DA2, DA3, DA5, DA6)	DIN 3852 ⁵⁾	M14 x 1.5; 12 deep	40	X
M ₁	Measuring stroking chamber	DIN 3852 ⁵⁾	M14 x 1.5; 12 deep	450	X

- 1) Observe the general instructions on page 80 for the maximum tightening torques.
- 2) Momentary pressure spikes may occur depending on the application. Keep this in mind when selecting measuring devices and fittings.
- 3) Only dimensions according to SAE J518, metric fastening thread is a deviation from standard.
- 4) Depending on installation position, T₁ or T₂ must be connected (see also installation instructions on page 79).
- 5) The spot face can be deeper than specified in the appropriate standard.
- 6) O = Must be connected (plugged on delivery)
X = Plugged (in normal operation)

Dimensions size 28

Before finalizing your design, request a binding installation drawing. Dimensions in mm.

EP.D

Proportional control electric,
with pressure control fixed setting

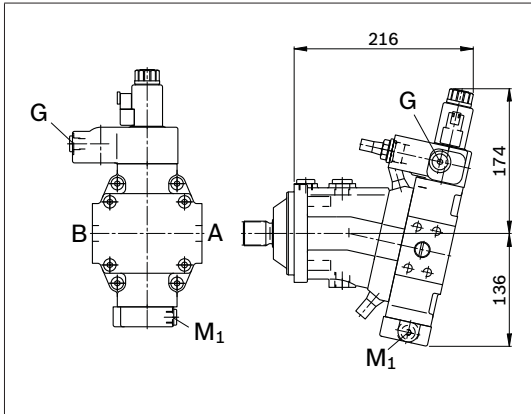

EP.E

Proportional control electric,
with pressure control hydraulic override, two-point

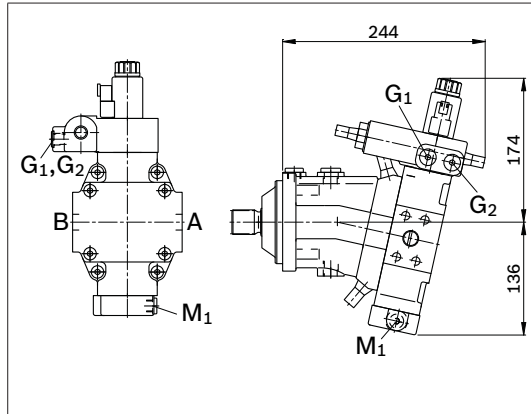

HD1, HD2

Proportional control hydraulic

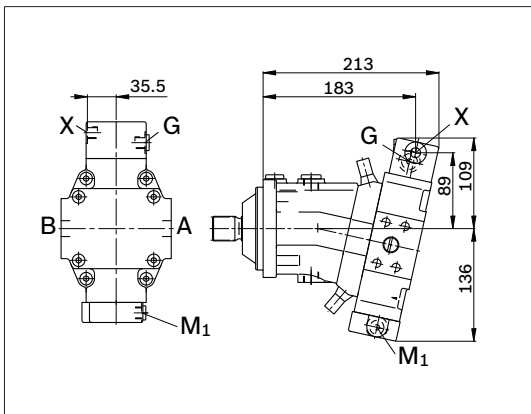

HD.D

Proportional control hydraulic,
with pressure control fixed setting

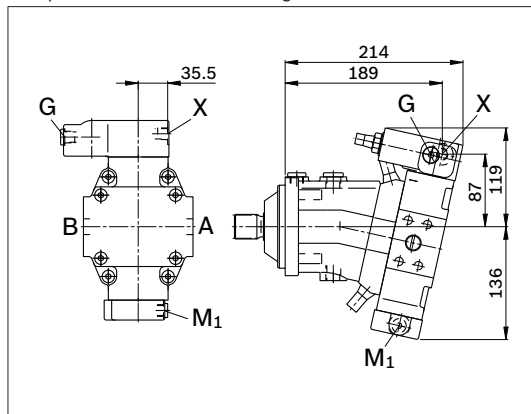

HD.E

Proportional control hydraulic,
with pressure control hydraulic override, two-point

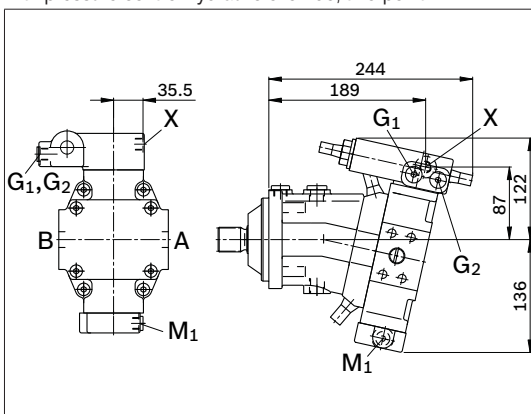

HZ1

Two-point control hydraulic

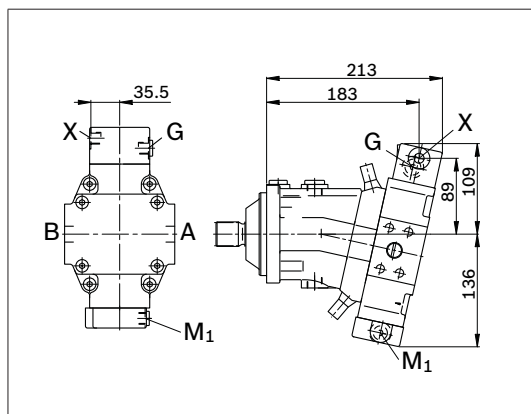

Dimensions size 28

Before finalizing your design, request a binding installation drawing. Dimensions in mm.

EZ1, EZ2

Two-point control electric

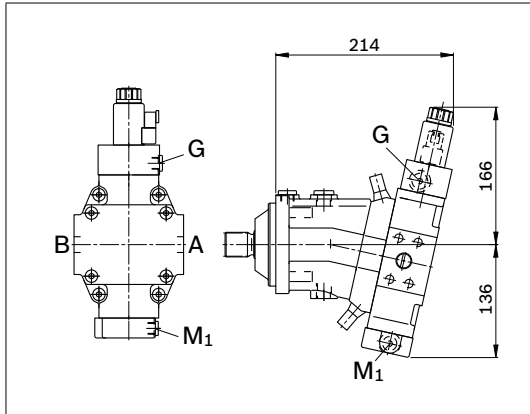

HA1, HA2 / HA1T, HA2T

Automatic control high-pressure related,
with override hydraulic remote control, proportional

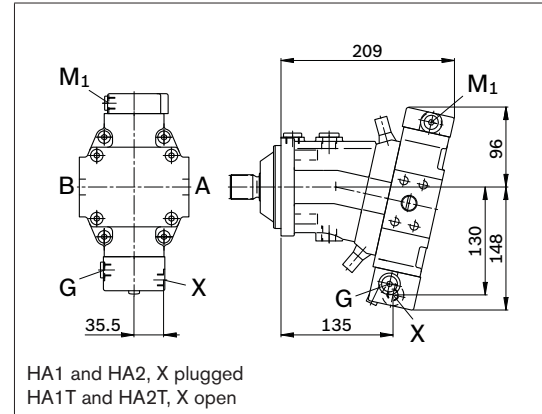

HA1 and HA2, X plugged
HA1T and HA2T, X open

HA1U1, HA2U2

Automatic control high-pressure related,
with override electric, two-point

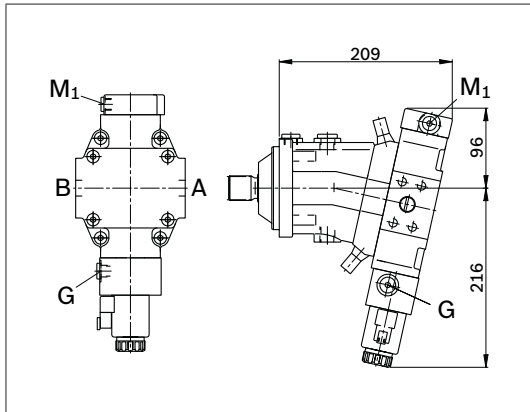

HA1R1, HA2R2

Automatic control high-pressure related,
with override electric and travel direction valve electric

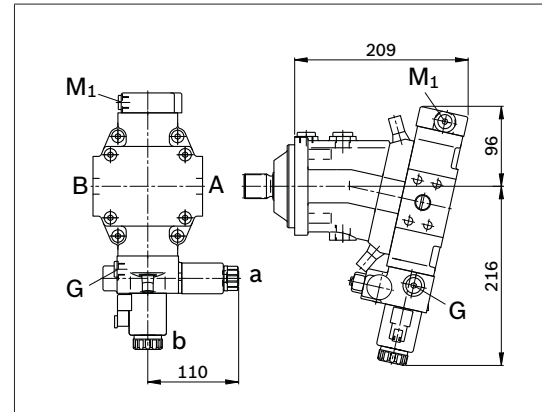

DA1, DA4

Automatic control speed related,
with hydraulic travel direction valve

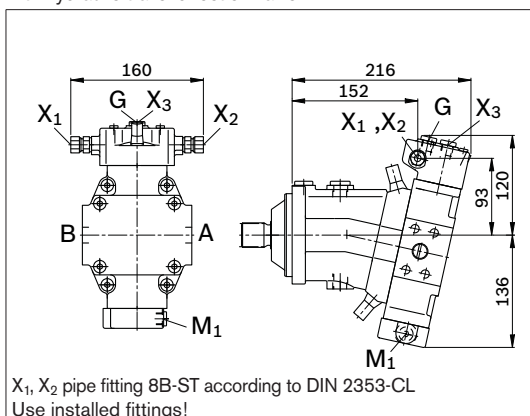

X₁, X₂ pipe fitting 8B-ST according to DIN 2353-CL
Use installed fittings!

DA2, DA3, DA5, DA6

Automatic control speed related,
with electric travel direction valve and electric V_{g max}-circuit

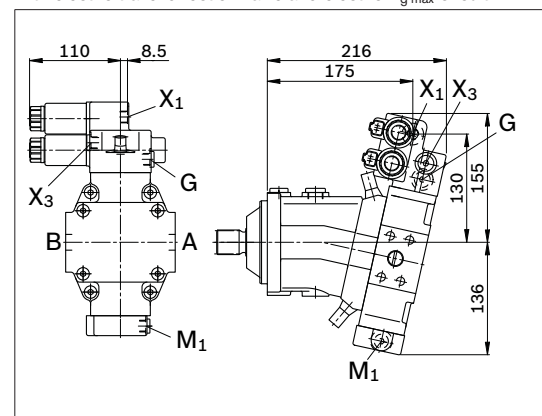

Dimensions size 55

Before finalizing your design, request a binding installation drawing. Dimensions in mm.

EP1, EP2 – Proportional control electric

Port plate 02 – SAE flange ports A and B at side, opposite

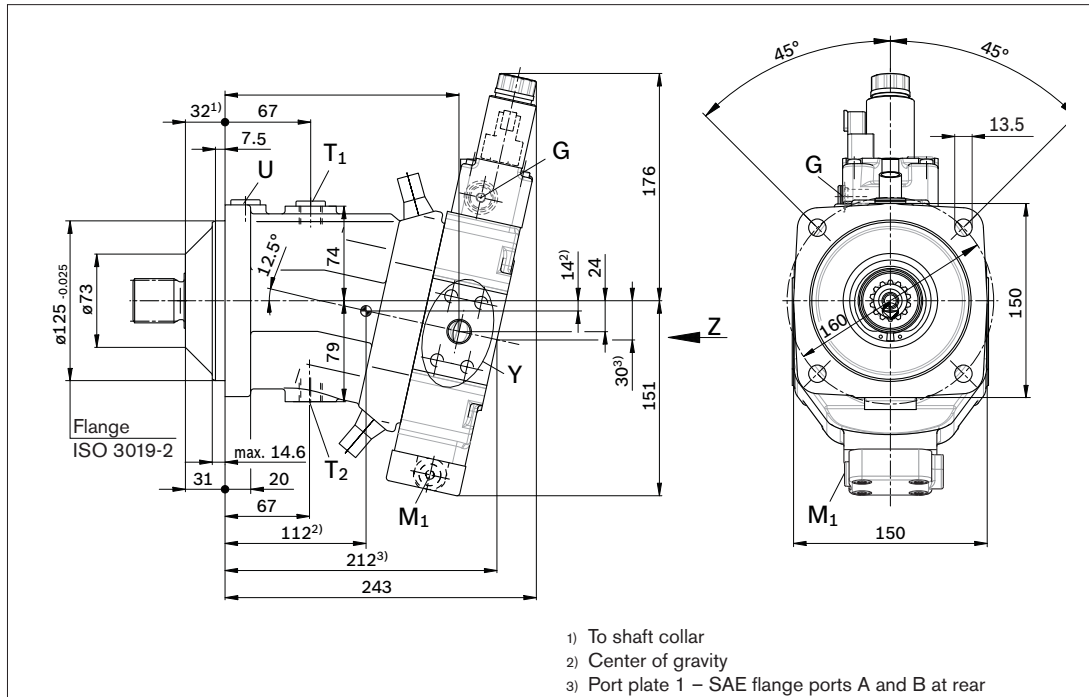

Drive shafts

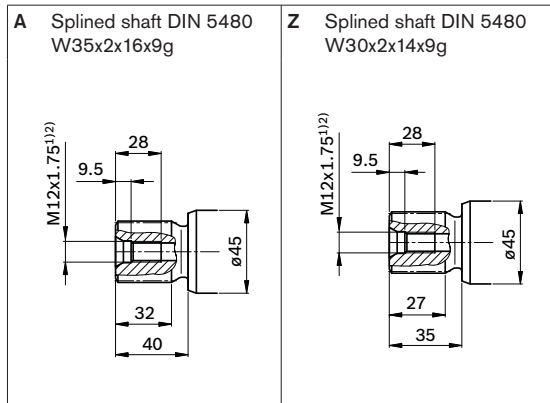

Service line port (detail Y)

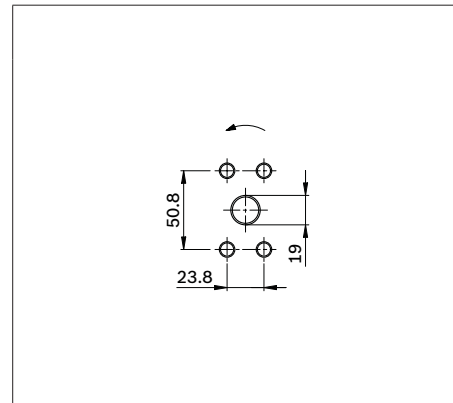

- 1) Observe the general instructions on page 80 for the maximum tightening torques.
- 2) Center bore according to DIN 332 (thread according to DIN 13)

Dimensions size 55

Before finalizing your design, request a binding installation drawing. Dimensions in mm.

Location of the service line ports on the port plates (view Z)

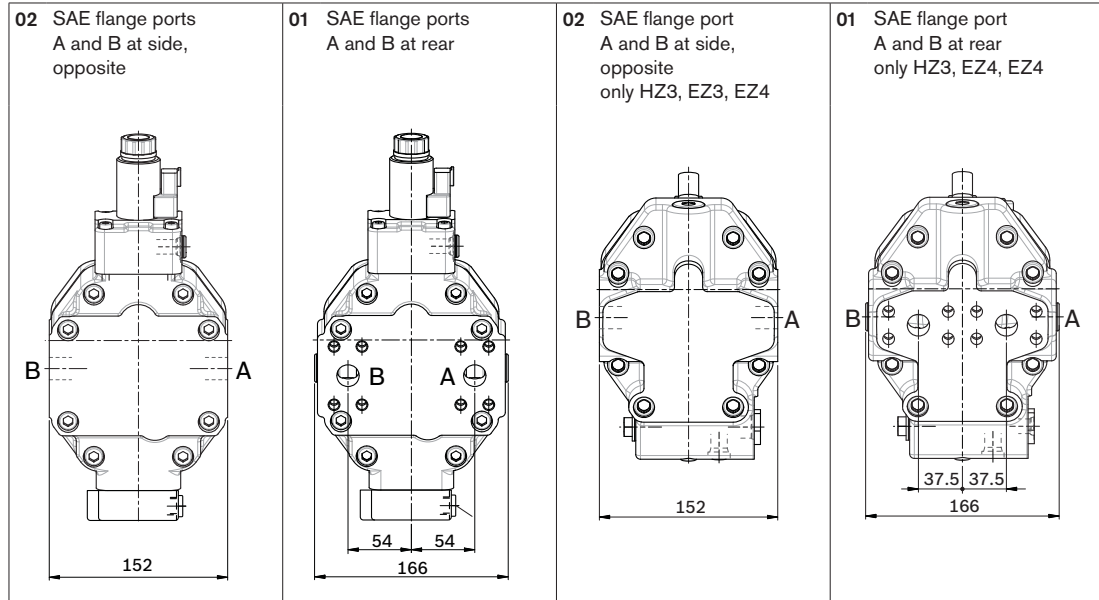

Ports

Designation	Port for	Standard	Size ¹⁾	Maximum pressure [bar] ²⁾	State ⁶⁾
A, B	Service line Fastening thread A/B	SAE J518 ³⁾ DIN 13	3/4 in M10 x 1.5; 17 deep	450	O
T ₁	Drain line	DIN 3852 ⁵⁾	M18 x 1.5; 12 deep	3	X ⁴⁾
T ₂	Drain line	DIN 3852 ⁵⁾	M18 x 1.5; 12 deep	3	O ⁴⁾
G	Synchronous control	DIN 3852 ⁵⁾	M14 x 1.5; 12 deep	450	X
G ₂	2nd pressure setting (HD,E, EPE)	DIN 3852 ⁵⁾	M14 x 1.5; 12 deep	100	X
U	Bearing flushing	DIN 3852 ⁵⁾	M18 x 1.5; 12 deep	3	X
X	Pilot signal (HD, HZ, HA1T/HA2T)	DIN 3852 ⁵⁾	M14 x 1.5; 12 deep	100	O
X	Pilot signal (HA1 and HA2)	DIN 3852 ⁵⁾	M14 x 1.5; 12 deep	3	X
X ₁ , X ₂	Pilot signal (DA1, DA4)	DIN 2353-CL	8B-ST	40	O
X ₁	Pilot signal (DA2, DA3, DA5, DA6)	DIN 3852 ⁵⁾	M14 x 1.5; 12 deep	40	O
X ₃	Pilot signal (DA2, DA3, DA5, DA6)	DIN 3852 ⁵⁾	M14 x 1.5; 12 deep	40	X
M ₁	Measuring stroking chamber	DIN 3852 ⁵⁾	M14 x 1.5; 12 deep	450	X

- 1) Observe the general instructions on page 80 for the maximum tightening torques.
- 2) Momentary pressure spikes may occur depending on the application. Keep this in mind when selecting measuring devices and fittings.
- 3) Only dimensions according to SAE J518, metric fastening thread is a deviation from standard.
- 4) Depending on installation position, T₁ or T₂ must be connected (see also installation instructions on page 79).
- 5) The spot face can be deeper than specified in the appropriate standard.
- 6) O = Must be connected (plugged on delivery)
X = Plugged (in normal operation)

Dimensions size 55

Before finalizing your design, request a binding installation drawing. Dimensions in mm.

EP.D

Proportional control electric,
with pressure control fixed setting

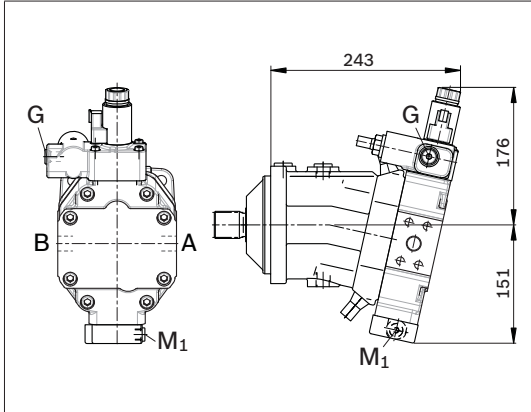

EP.E

Proportional control electric,
with pressure control hydraulic override, two-point

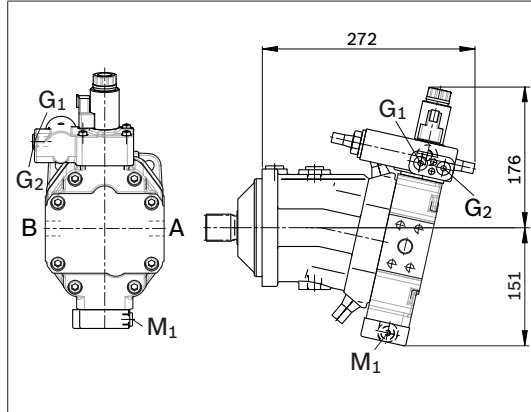

HD1, HD2

Proportional control hydraulic

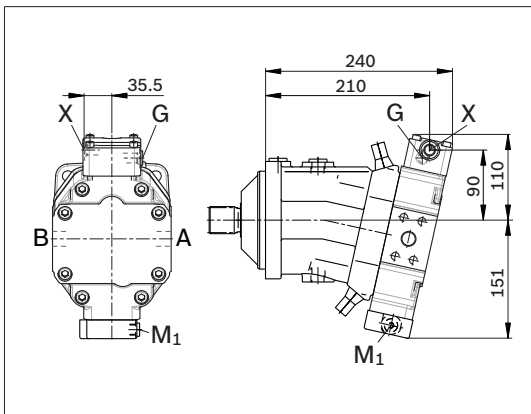

HD.D

Proportional control hydraulic,
with pressure control fixed setting

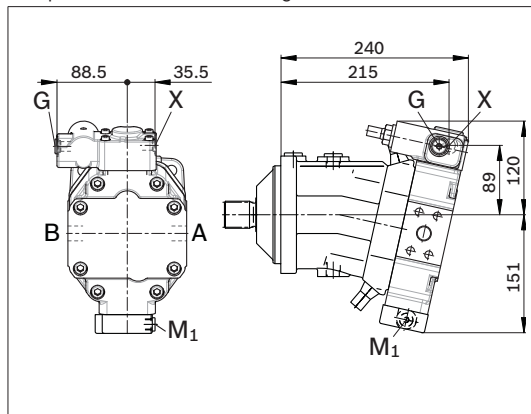

HD.E

Proportional control hydraulic,
with pressure control hydraulic override, two-point

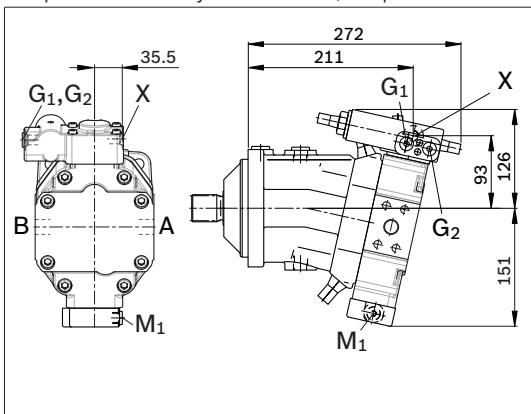

HZ3

Two-point control hydraulic

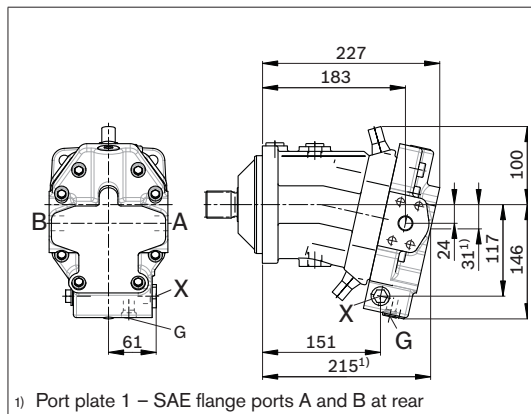

1) Port plate 1 – SAE flange ports A and B at rear

Dimensions size 55

Before finalizing your design, request a binding installation drawing. Dimensions in mm.

EZ3, EZ4

Two-point control electric

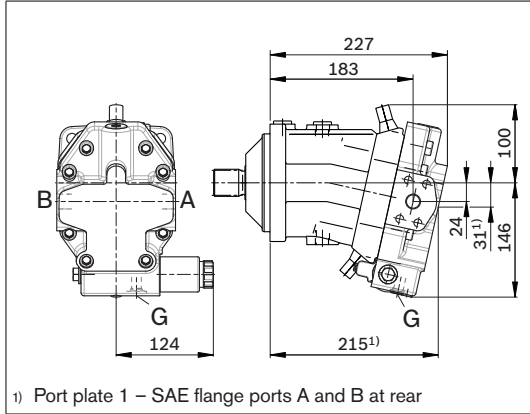

HA1, HA2 / HA1T, HA2T

Automatic control high-pressure related,
with override hydraulic remote control, proportional

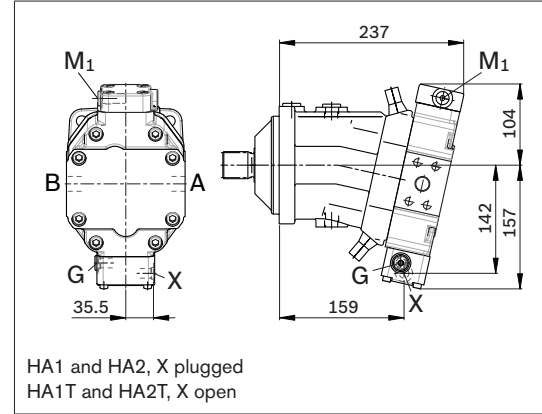

HA1U1, HA2U2

Automatic control high-pressure related,
with override electric, two-point

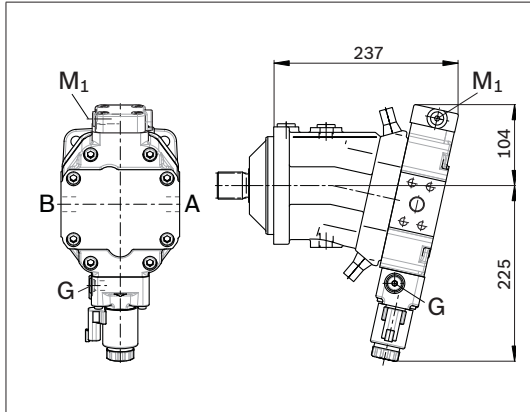

HA1R1, HA2R2

Automatic control high-pressure related,
with override electric and travel direction valve electric

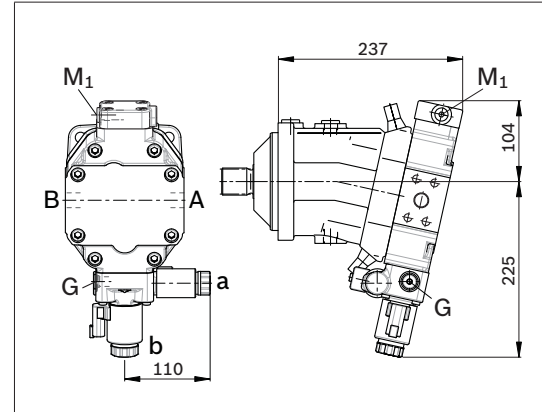

DA1, DA4

Automatic control speed related,
with hydraulic travel direction valve

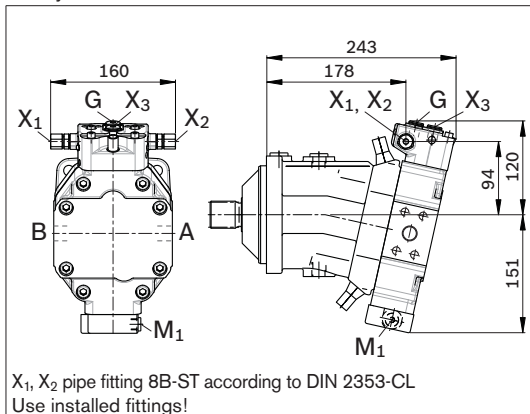

DA2, DA3, DA5, DA6

Automatic control speed related,
with electric travel direction valve and electric V_{g max}-circuit

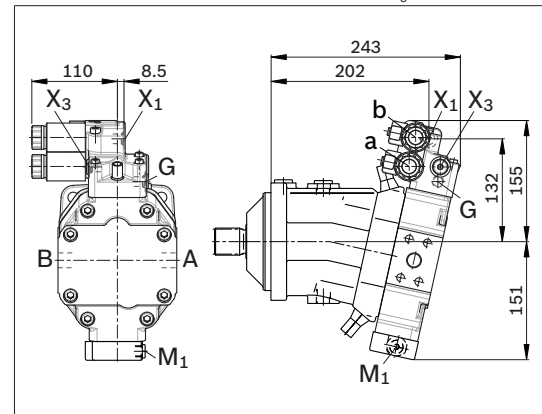

Dimensions size 80

Before finalizing your design, request a binding installation drawing. Dimensions in mm.

EP1, EP2 – Proportional control electric

Port plate 02 – SAE flange ports A and B at side, opposite

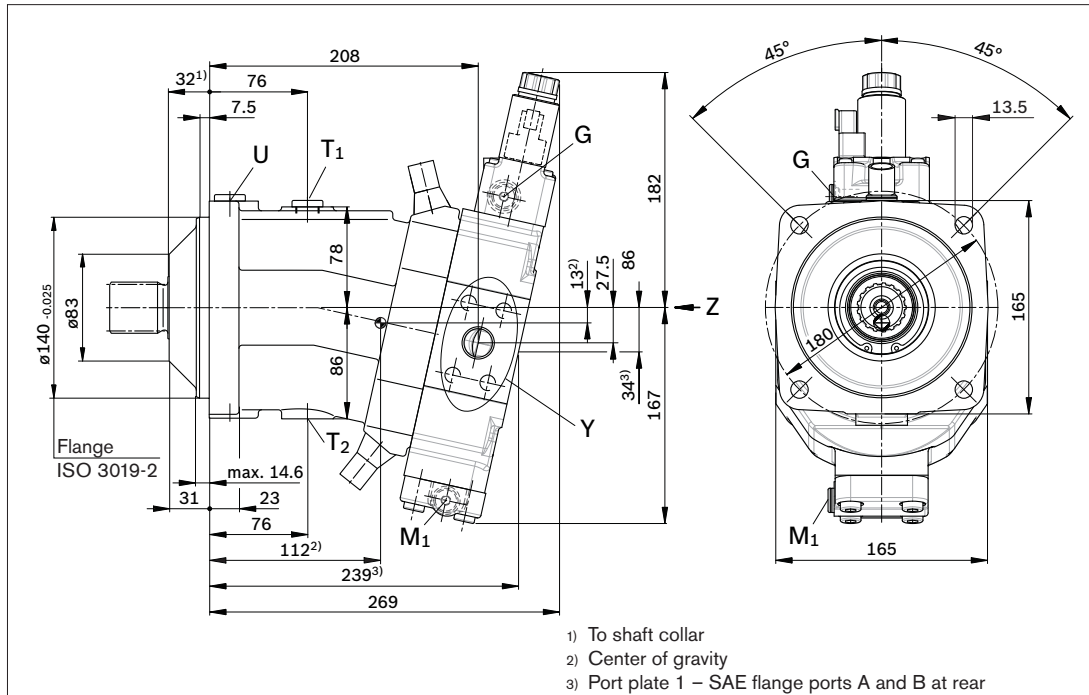

Drive shafts

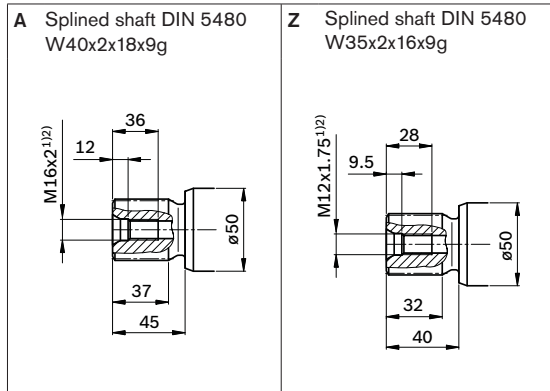

Service line port (detail Y)

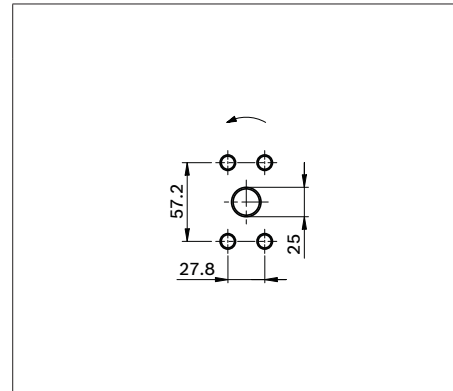

- 1) Observe the general instructions on page 80 for the maximum tightening torques.
- 2) Center bore according to DIN 332 (thread according to DIN 13)

Dimensions size 80

Before finalizing your design, request a binding installation drawing. Dimensions in mm.

Location of the service line ports on the port plates (view Z)

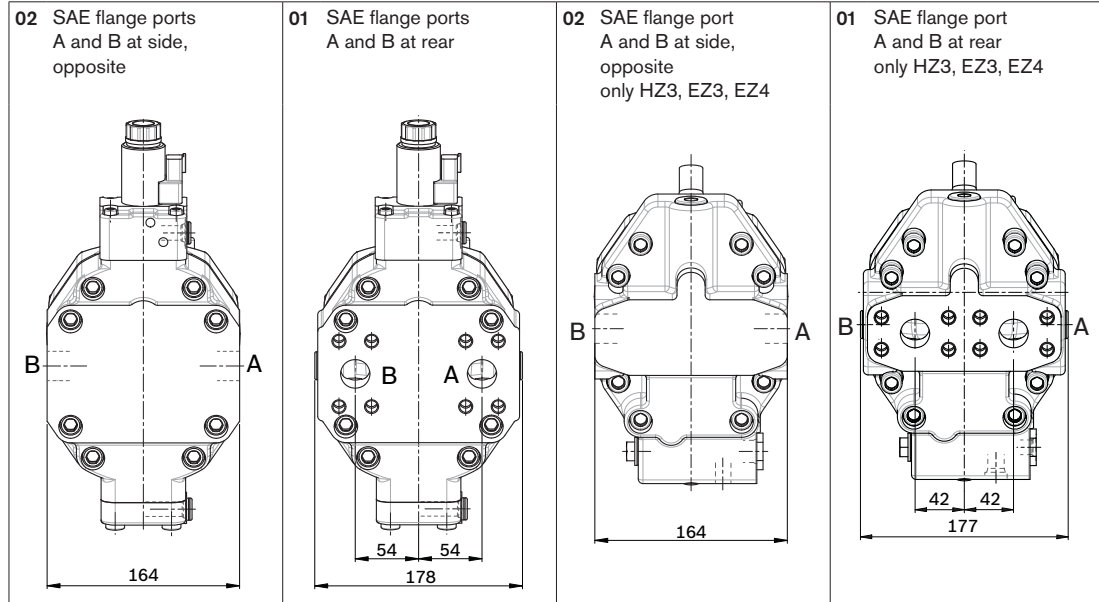

Ports

Designation	Port for	Standard	Size ¹⁾	Maximum pressure [bar] ²⁾	State ⁶⁾
A, B	Service line Fastening thread A/B	SAE J518 ³⁾ DIN 13	1 in M12 x 1.75; 17 deep	450	O
T ₁	Drain line	DIN 3852 ⁵⁾	M18 x 1.5; 12 deep	3	X ⁴⁾
T ₂	Drain line	DIN 3852 ⁵⁾	M18 x 1.5; 12 deep	3	O ⁴⁾
G	Synchronous control	DIN 3852 ⁵⁾	M14 x 1.5; 12 deep	450	X
G ₂	2nd pressure setting (HD,E, E,P,E)	DIN 3852 ⁵⁾	M14 x 1.5; 12 deep	100	X
U	Bearing flushing	DIN 3852 ⁵⁾	M18 x 1.5; 12 deep	3	X
X	Pilot signal (HD, HZ, HA1T/HA2T)	DIN 3852 ⁵⁾	M14 x 1.5; 12 deep	100	O
X	Pilot signal (HA1 and HA2)	DIN 3852 ⁵⁾	M14 x 1.5; 12 deep	3	X
X ₁ , X ₂	Pilot signal (DA1, DA4)	DIN 2353-CL	8B-ST	40	O
X ₁	Pilot signal (DA2, DA3, DA5, DA6)	DIN 3852 ⁵⁾	M14 x 1.5; 12 deep	40	O
X ₃	Pilot signal (DA2, DA3, DA5, DA6)	DIN 3852 ⁵⁾	M14 x 1.5; 12 deep	40	X
M ₁	Measuring stroking chamber	DIN 3852 ⁵⁾	M14 x 1.5; 12 deep	450	X

- 1) Observe the general instructions on page 80 for the maximum tightening torques.
- 2) Momentary pressure spikes may occur depending on the application. Keep this in mind when selecting measuring devices and fittings.
- 3) Only dimensions according to SAE J518, metric fastening thread is a deviation from standard.
- 4) Depending on installation position, T₁ or T₂ must be connected (see also installation instructions on page 79).
- 5) The spot face can be deeper than specified in the appropriate standard.
- 6) O = Must be connected (plugged on delivery)
X = Plugged (in normal operation)

Dimensions size 80

Before finalizing your design, request a binding installation drawing. Dimensions in mm.

EP.D

Proportional control electric,
with pressure control fixed setting

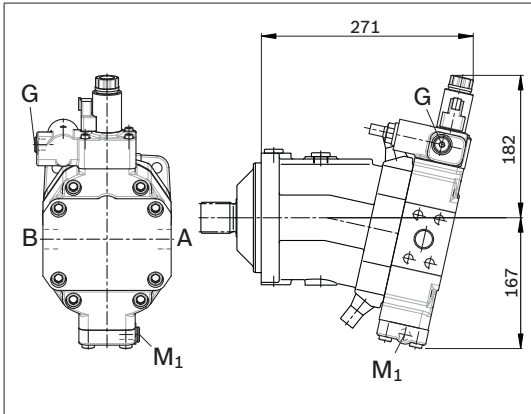

EP.E

Proportional control electric,
with pressure control hydraulic override, two-point

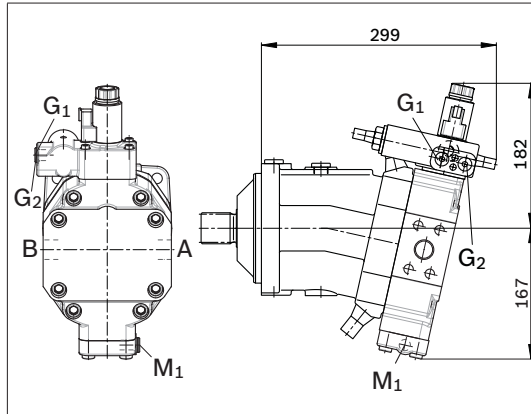

HD1, HD2

Proportional control hydraulic

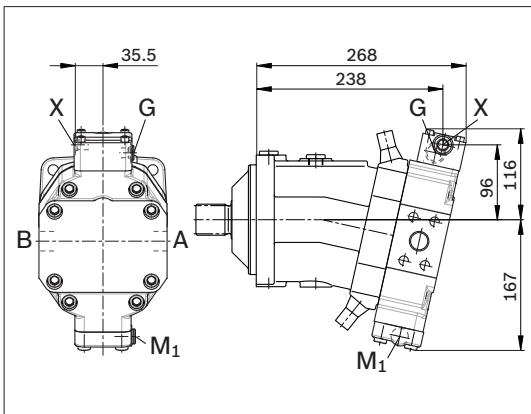

HD.D

Proportional control hydraulic,
with pressure control fixed setting

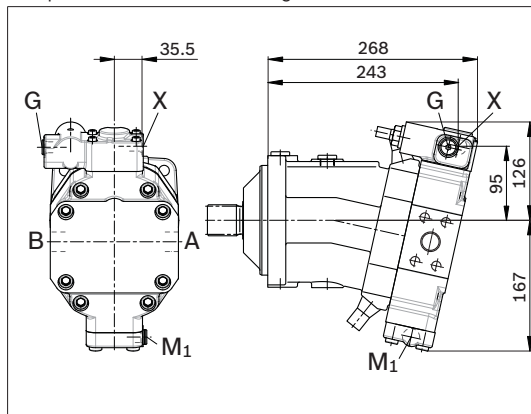

HD.E

Proportional control hydraulic,
with pressure control hydraulic override, two-point

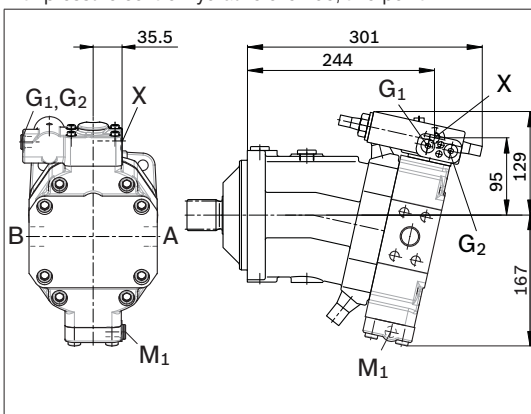

HZ3

Two-point control hydraulic

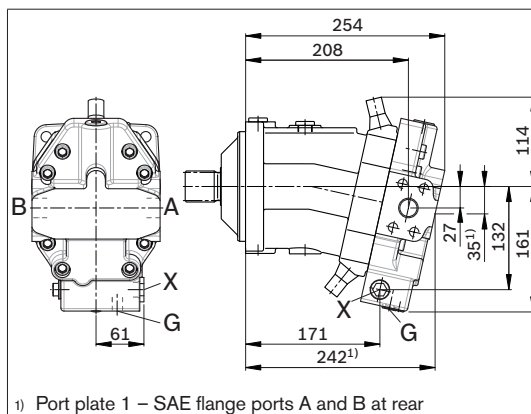

1) Port plate 1 – SAE flange ports A and B at rear

Dimensions size 80

Before finalizing your design, request a binding installation drawing. Dimensions in mm.

EZ3, EZ4

Two-point control electric

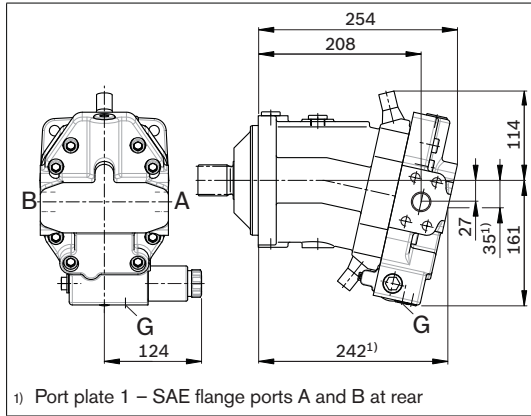

HA1, HA2 / HA1T, HA2T

Automatic control high-pressure related,
with override hydraulic remote control, proportional

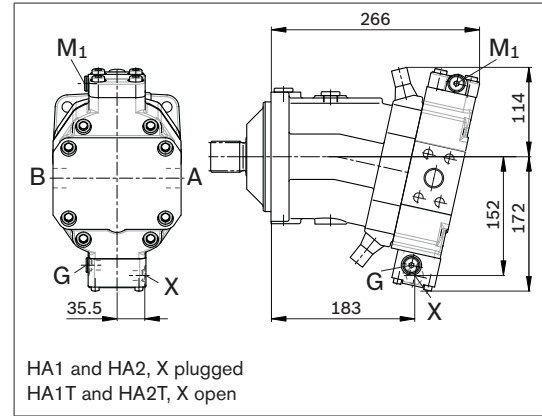

HA1U1, HA2U2

Automatic control high-pressure related,
with override electric, two-point

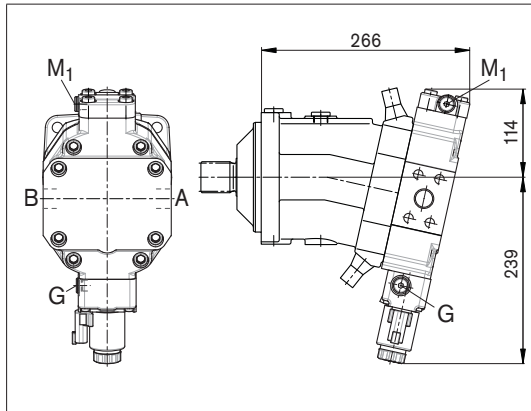

HA1R1, HA2R2

Automatic control high-pressure related,
with override electric and travel direction valve electric

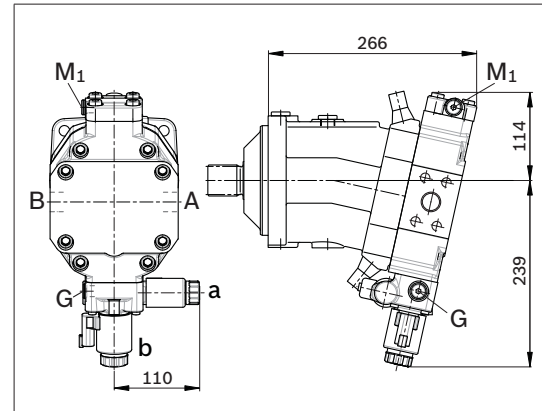

DA1, DA4

Automatic control speed related,
with hydraulic travel direction valve

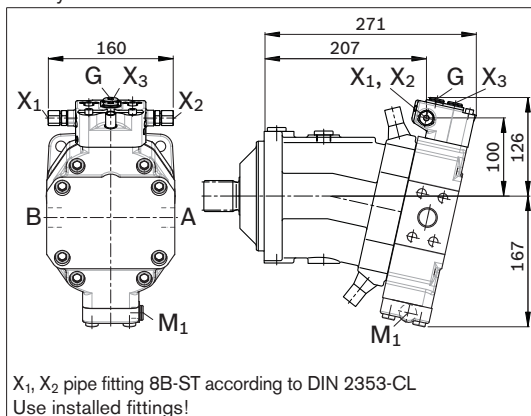

DA2, DA3, DA5, DA6

Automatic control speed related,
with electric travel direction valve and electric V_{g max}-circuit

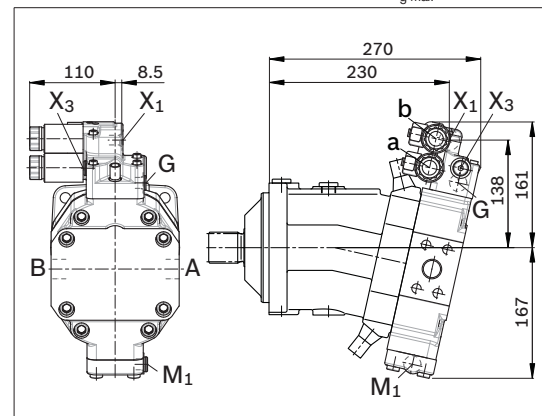

Dimensions size 107

Before finalizing your design, request a binding installation drawing. Dimensions in mm.

EP1, EP2 – Proportional control electric

Port plate 02 – SAE- SAE flange ports A and B at side, opposite

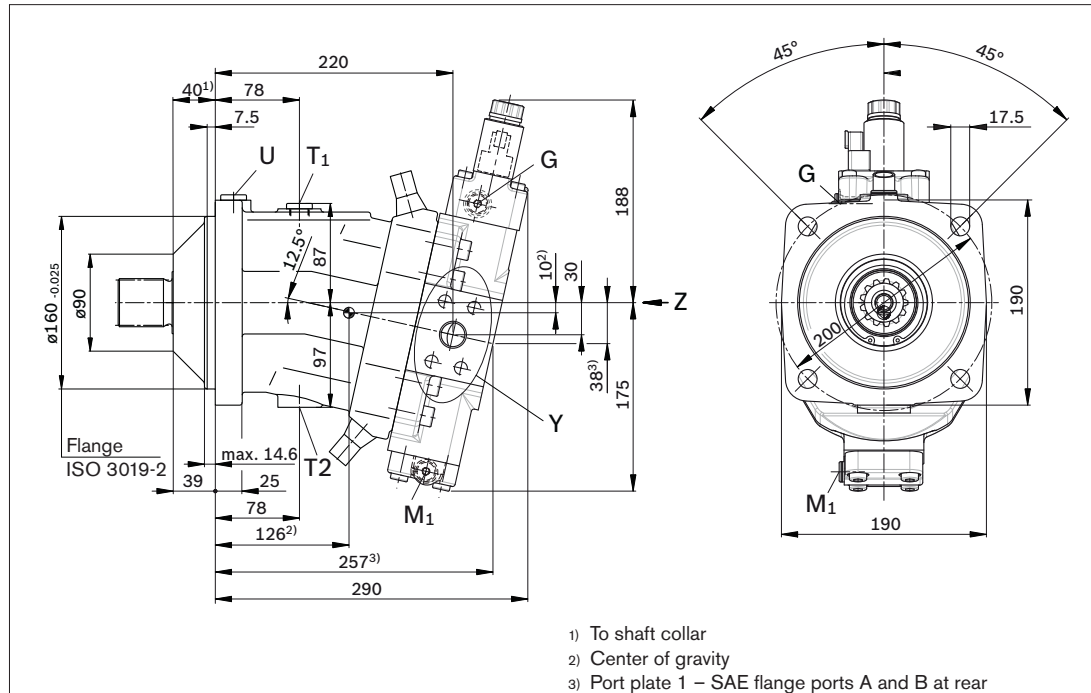

Drive shafts

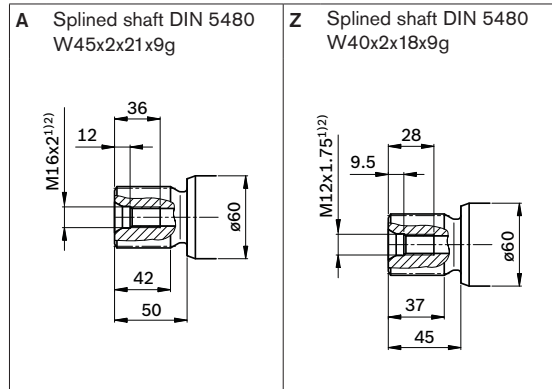

Service line port (detail Y)

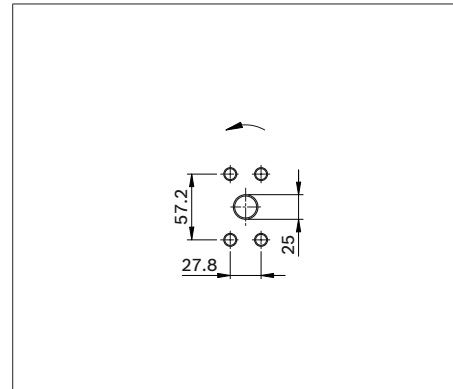

- 1) Observe the general instructions on page 80 for the maximum tightening torques.
- 2) Center bore according to DIN 332 (thread according to DIN 13)

Dimensions size 107

Before finalizing your design, request a binding installation drawing. Dimensions in mm.

Location of the service line ports on the port plates (view Z)

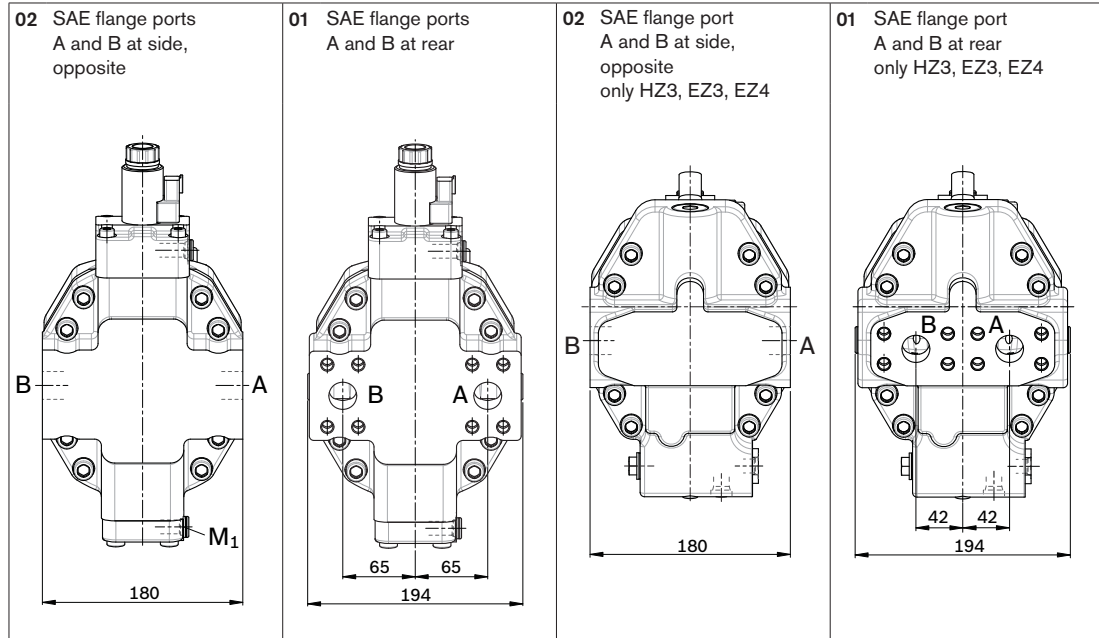

Ports

Designation	Port for	Standard	Size ¹⁾	Maximum pressure [bar] ²⁾	State ⁶⁾
A, B	Service line Fastening thread A/B	SAE J518 ³⁾ DIN 13	1 in M12 x 1.75; 17 deep	450	O
T ₁	Drain line	DIN 3852 ⁵⁾	M18 x 1.5; 12 deep	3	X ⁴⁾
T ₂	Drain line	DIN 3852 ⁵⁾	M18 x 1.5; 12 deep	3	O ⁴⁾
G	Synchronous control	DIN 3852 ⁵⁾	M14 x 1.5; 12 deep	450	X
G ₂	2nd pressure setting (HD,E, EPE)	DIN 3852 ⁵⁾	M14 x 1.5; 12 deep	100	X
U	Bearing flushing	DIN 3852 ⁵⁾	M18 x 1.5; 12 deep	3	X
X	Pilot signal (HD, HZ, HA1T/HA2T)	DIN 3852 ⁵⁾	M14 x 1.5; 12 deep	100	O
X	Pilot signal (HA1 and HA2)	DIN 3852 ⁵⁾	M14 x 1.5; 12 deep	3	X
X ₁ , X ₂	Pilot signal (DA1, DA4)	DIN 2353-CL	8B-ST	40	O
X ₁	Pilot signal (DA2, DA3, DA5, DA6)	DIN 3852 ⁵⁾	M14 x 1.5; 12 deep	40	O
X ₃	Pilot signal (DA2, DA3, DA5, DA6)	DIN 3852 ⁵⁾	M14 x 1.5; 12 deep	40	X
M ₁	Measuring stroking chamber	DIN 3852 ⁵⁾	M14 x 1.5; 12 deep	450	X

1) Observe the general instructions on page 80 for the maximum tightening torques.

2) Momentary pressure spikes may occur depending on the application. Keep this in mind when selecting measuring devices and fittings.

3) Only dimensions according to SAE J518, metric fastening thread is a deviation from standard.

4) Depending on installation position, T₁ or T₂ must be connected (see also installation instructions on page 79).

5) The spot face can be deeper than specified in the appropriate standard.

6) O = Must be connected (plugged on delivery)

X = Plugged (in normal operation)

Dimensions size 107

Before finalizing your design, request a binding installation drawing. Dimensions in mm.

EP.D

Proportional control electric,
with pressure control fixed setting

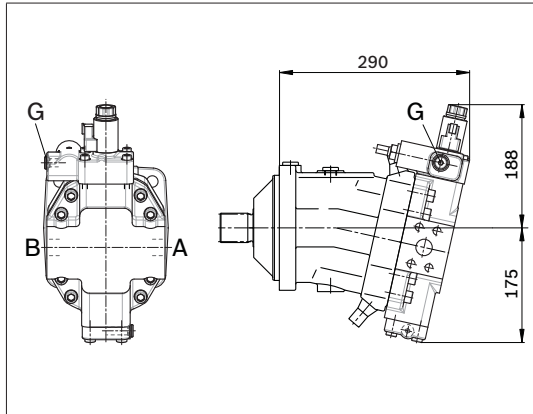

EP.E

Proportional control electric,
with pressure control hydraulic override, two-point

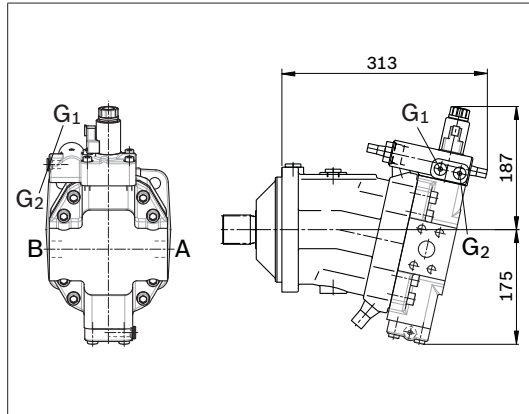

HD1, HD2

Proportional control hydraulic

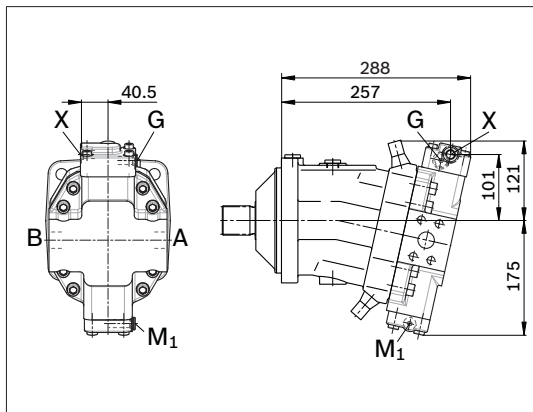

HD.D

Proportional control hydraulic,
with pressure control fixed setting

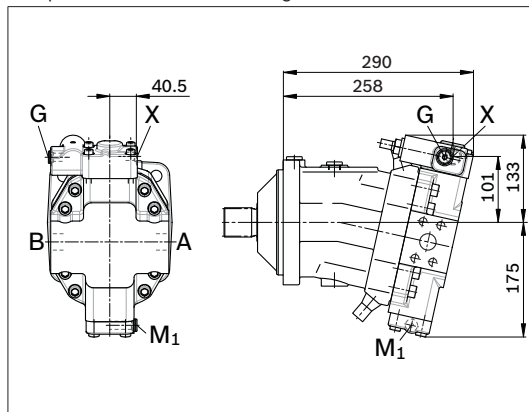

HD.E

Proportional control hydraulic,
with pressure control hydraulic override, two-point

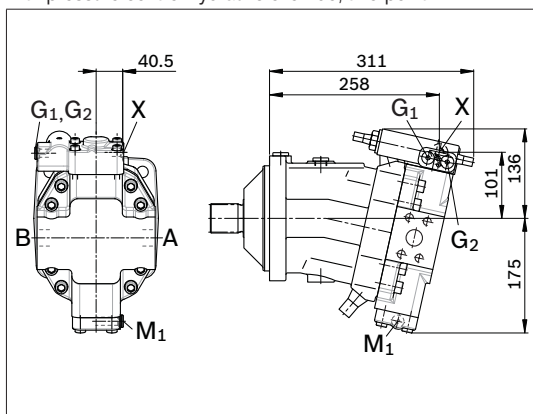

HZ3

Two-point control hydraulic

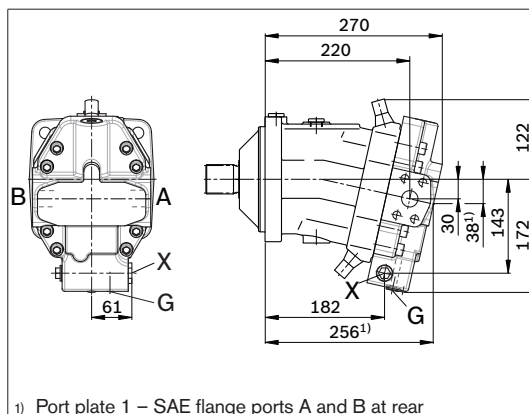

1) Port plate 1 – SAE flange ports A and B at rear

Dimensions size 107

Before finalizing your design, request a binding installation drawing. Dimensions in mm.

EZ3, EZ4

Two-point control electric

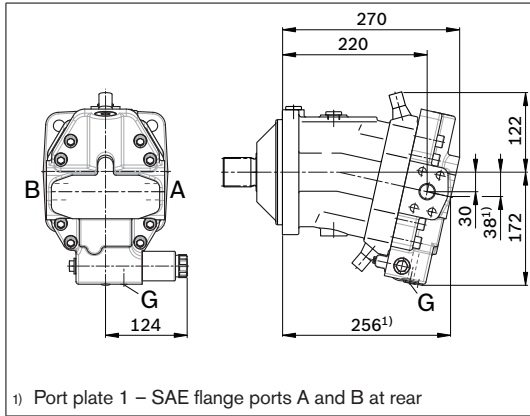

HA1, HA2 / HA1T, HA2T

Automatic control high-pressure related,
with override hydraulic remote control, proportional

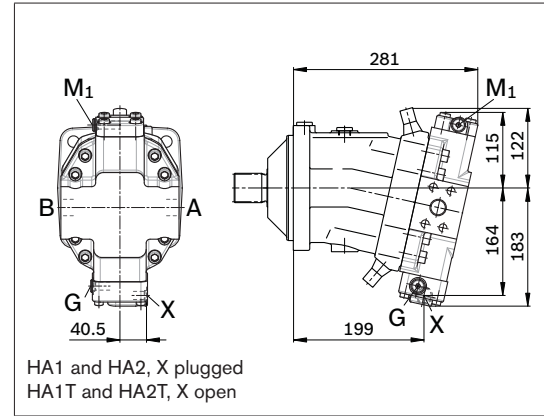

HA1U1, HA2U2

Automatic control high-pressure related,
with override electric, two-point

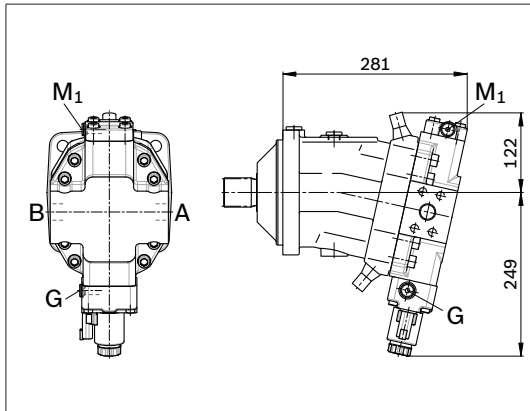

HA1R1, HA2R2

Automatic control high-pressure related,
with override electric and travel direction valve electric

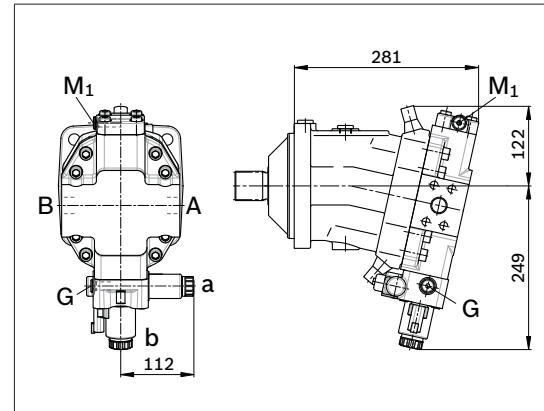

DA1, DA4

Automatic control speed related,
with hydraulic travel direction valve

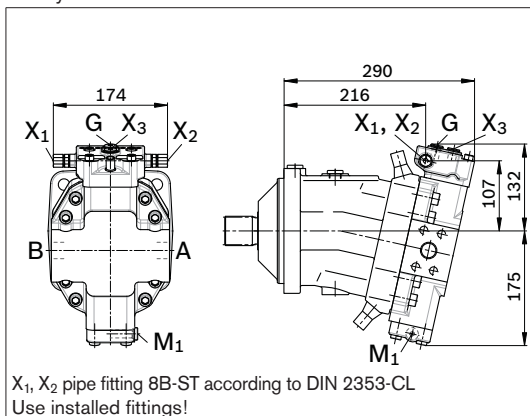

DA2, DA3, DA5, DA6

Automatic control speed related,
with electric travel direction valve and electric V_{g max}-circuit

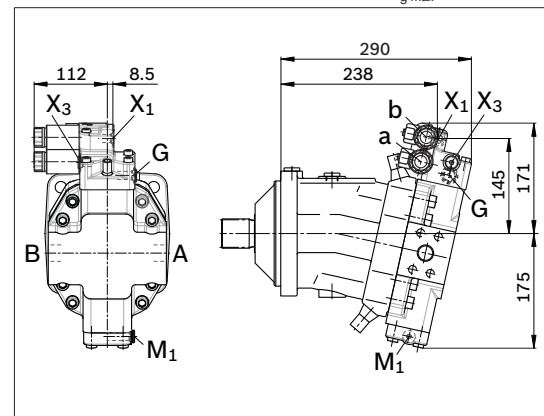

Dimensions size 140

Before finalizing your design, request a binding installation drawing. Dimensions in mm.

EP1, EP2 – Proportional control electric

Port plate 02 – SAE flange ports A and B at side, opposite

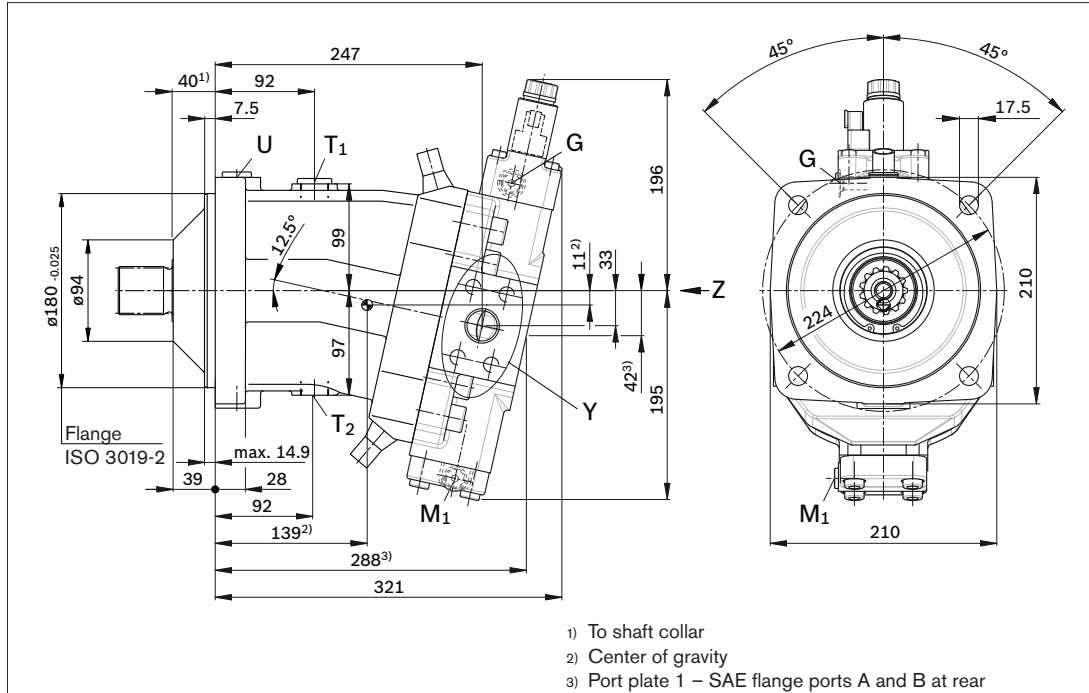

Drive shaft

Z Splined shaft DIN 5480
W45x2x21x9g

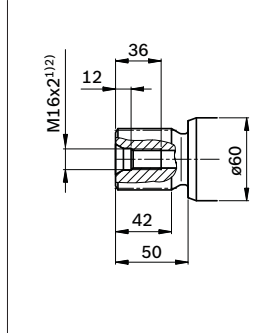

Service line port (detail Y)

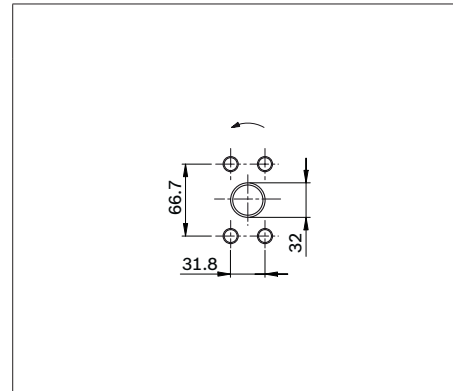

- 1) Observe the general instructions on page 80 for the maximum tightening torques.
- 2) Center bore according to DIN 332 (thread according to DIN 13)

Dimensions size 140

Before finalizing your design, request a binding installation drawing. Dimensions in mm.

Location of the service line ports on the port plates (view Z)

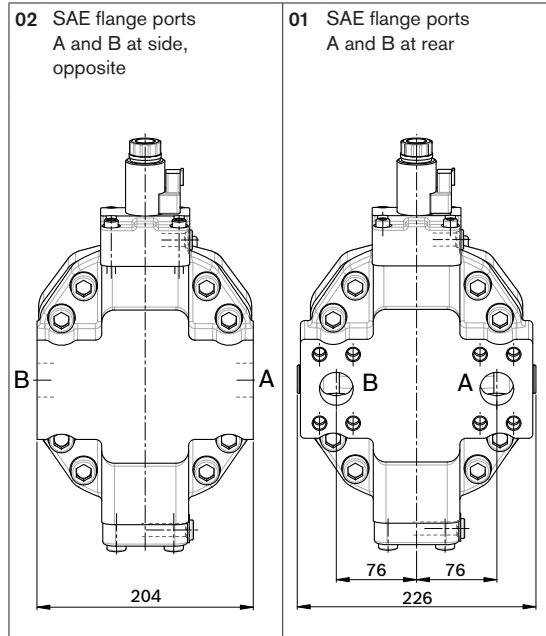

Ports

Designation	Port for	Standard	Size ¹⁾	Maximum pressure [bar] ²⁾	State ⁶⁾
A, B	Service line Fastening thread A/B	SAE J518 ³⁾ DIN 13	1 1/4 in M14 x 2; 19 deep	450	O
T ₁	Drain line	DIN 3852 ⁵⁾	M26 x 1.5; 16 deep	3	X ⁴⁾
T ₂	Drain line	DIN 3852 ⁵⁾	M26 x 1.5; 16 deep	3	O ⁴⁾
G	Synchronous control	DIN 3852 ⁵⁾	M14 x 1.5; 12 deep	450	X
G ₂	2nd pressure setting (HD,E, EPE)	DIN 3852 ⁵⁾	M14 x 1.5; 12 deep	100	X
U	Bearing flushing	DIN 3852 ⁵⁾	M22 x 1.5; 14 deep	3	X
X	Pilot signal (HD, HZ, HA1T/HA2T)	DIN 3852 ⁵⁾	M14 x 1.5; 12 deep	100	O
X	Pilot signal (HA1 and HA2)	DIN 3852 ⁵⁾	M14 x 1.5; 12 deep	3	X
X ₁ , X ₂	Pilot signal (DA1, DA4)	DIN 2353-CL	8B-ST	40	O
X ₁	Pilot signal (DA2, DA3, DA5, DA6)	DIN 3852 ⁵⁾	M14 x 1.5; 12 deep	40	O
X ₃	Pilot signal (DA2, DA3, DA5, DA6)	DIN 3852 ⁵⁾	M14 x 1.5; 12 deep	40	X
M ₁	Measuring stroking chamber	DIN 3852 ⁵⁾	M14 x 1.5; 12 deep	450	X

1) Observe the general instructions on page 80 for the maximum tightening torques.

2) Momentary pressure spikes may occur depending on the application. Keep this in mind when selecting measuring devices and fittings.

3) Only dimensions according to SAE J518, metric fastening thread is a deviation from standard.

4) Depending on installation position, T₁ or T₂ must be connected (see also installation instructions on page 79).

5) The spot face can be deeper than specified in the appropriate standard.

6) O = Must be connected (plugged on delivery)

X = Plugged (in normal operation)

Dimensions size 140

Before finalizing your design, request a binding installation drawing. Dimensions in mm.

EP.D

Proportional control electric,
with pressure control fixed setting

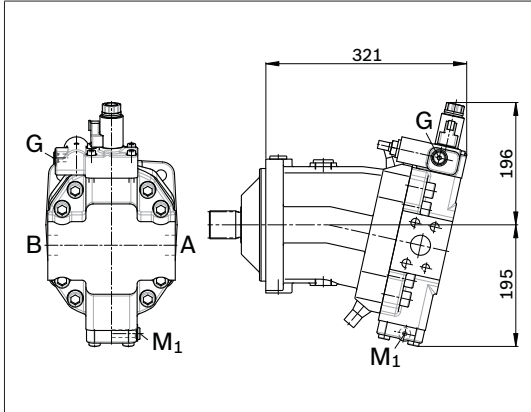

EP.E

Proportional control electric,
with pressure control hydraulic override, two-point

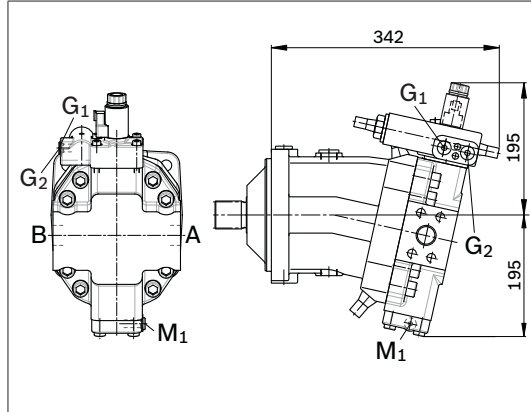

HD1, HD2

Proportional control hydraulic

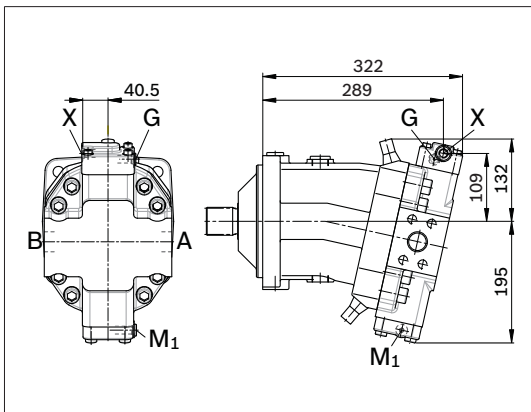

HD.D

Proportional control hydraulic,
with pressure control fixed setting

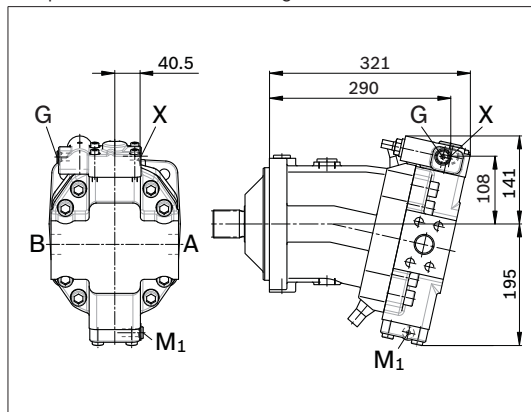

HD.E

Proportional control hydraulic,
with pressure control hydraulic override, two-point

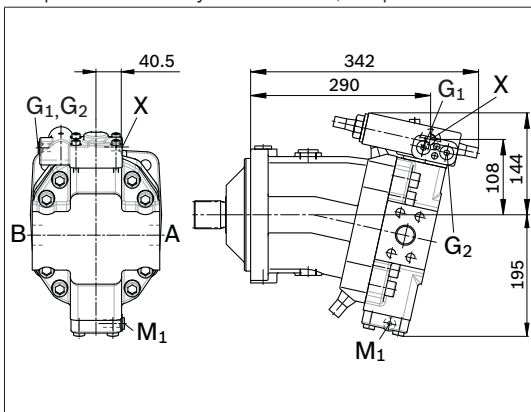

HZ1

Two-point control hydraulic

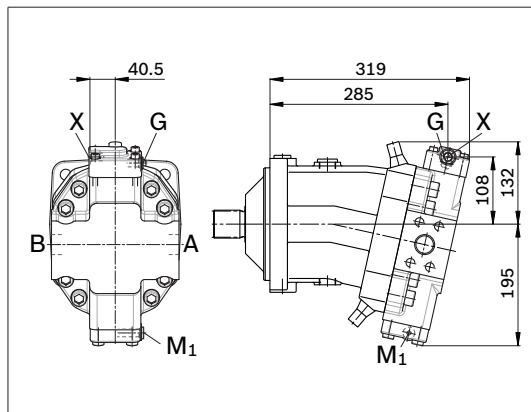

Dimensions size 140

Before finalizing your design, request a binding installation drawing. Dimensions in mm.

EZ1, EZ2

Two-point control electric

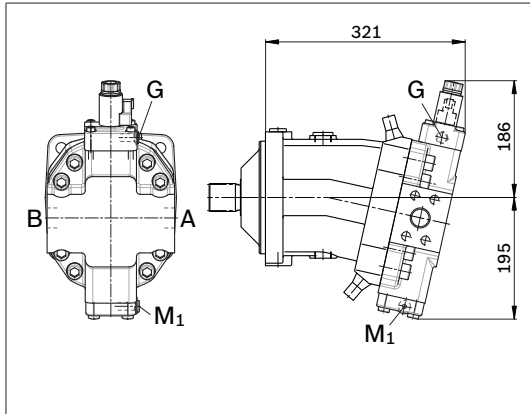

HA1, HA2 / HA1T, HA2T

Automatic control high-pressure related,
with override hydraulic remote control, proportional

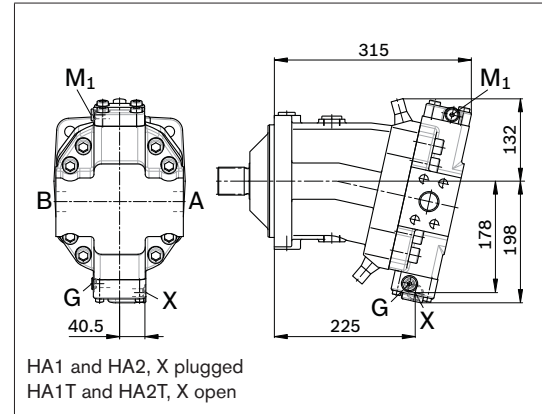

HA1 and HA2, X plugged
HA1T and HA2T, X open

HA1U1, HA2U2

Automatic control high-pressure related,
with override electric, two-point

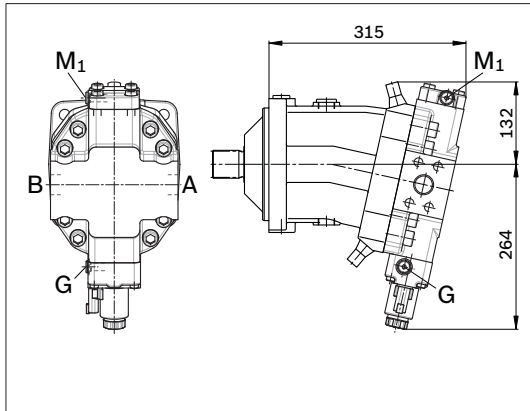

HA1R1, HA2R2

Automatic control high-pressure related,
with override electric and travel direction valve electric

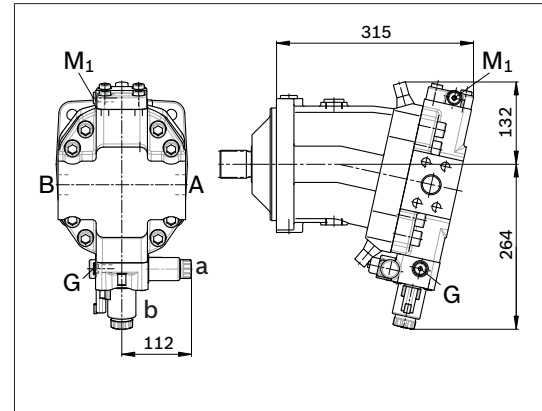

DA1, DA4

Automatic control speed related,
with hydraulic travel direction valve

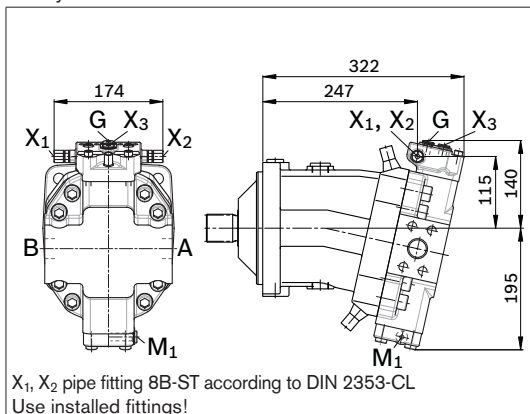

X₁, X₂ pipe fitting 8B-ST according to DIN 2353-CL
Use installed fittings!

DA2, DA3, DA5, DA6

Automatic control speed related,
with electric travel direction valve and electric V_{g max}-circuit

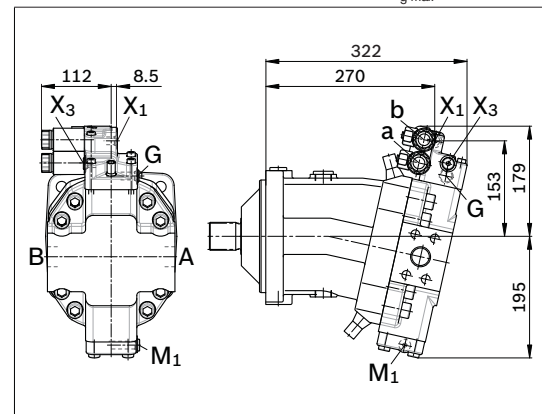

Dimensions size 160

Before finalizing your design, request a binding installation drawing. Dimensions in mm.

EP1, EP2 – Proportional control electric

Port plate 02 – SAE-SAE flange ports A and B at side, opposite

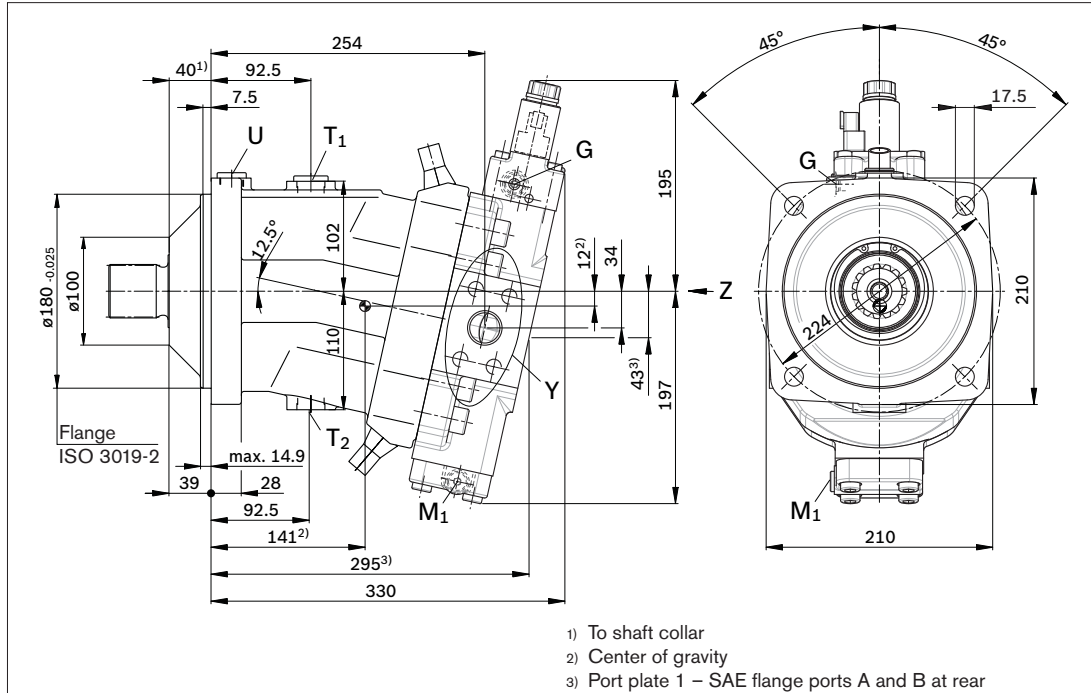

Drive shafts

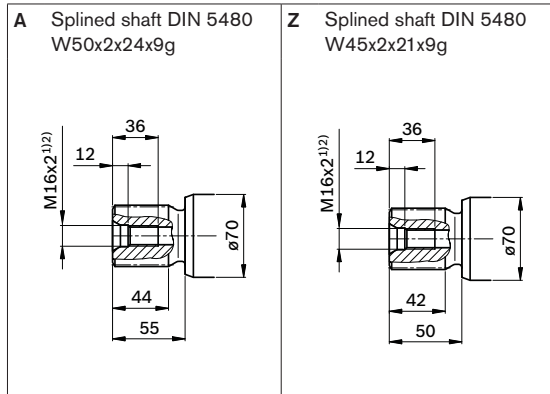

Service line port (detail Y)

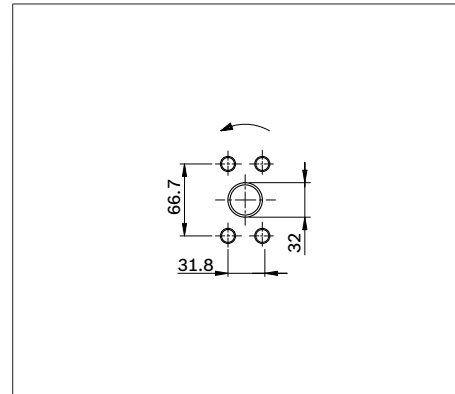

- 1) Observe the general instructions on page 80 for the maximum tightening torques.
- 2) Center bore according to DIN 332 (thread according to DIN 13)

Dimensions size 160

Before finalizing your design, request a binding installation drawing. Dimensions in mm.

Location of the service line ports on the port plates (view Z)

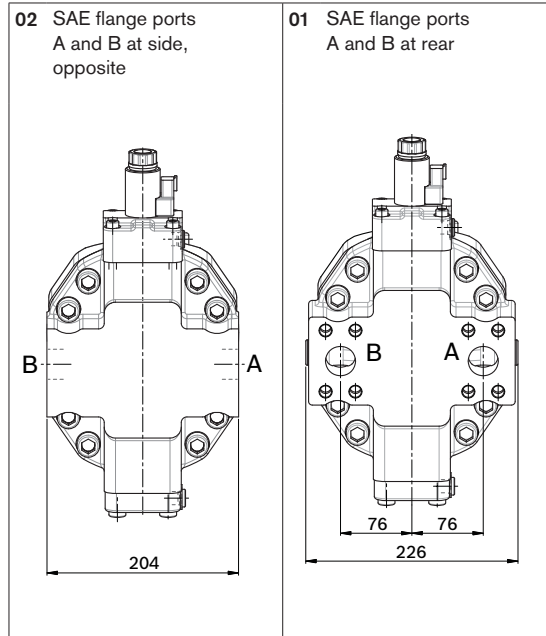

Ports

Designation	Port for	Standard	Size ¹⁾	Maximum pressure [bar] ²⁾	State ⁶⁾
A, B	Service line Fastening thread A/B	SAE J518 ³⁾ DIN 13	1 1/4 in M14 x 2; 19 deep	450	O
T ₁	Drain line	DIN 3852 ⁵⁾	M26 x 1.5; 16 deep	3	X ⁴⁾
T ₂	Drain line	DIN 3852 ⁵⁾	M26 x 1.5; 16 deep	3	O ⁴⁾
G	Synchronous control	DIN 3852 ⁵⁾	M14 x 1.5; 12 deep	450	X
G ₂	2nd pressure setting (HD,E, EPE)	DIN 3852 ⁵⁾	M14 x 1.5; 12 deep	100	X
U	Bearing flushing	DIN 3852 ⁵⁾	M22 x 1.5; 14 deep	3	X
X	Pilot signal (HD, HZ, HA1T/HA2T)	DIN 3852 ⁵⁾	M14 x 1.5; 12 deep	100	O
X	Pilot signal (HA1 and HA2)	DIN 3852 ⁵⁾	M14 x 1.5; 12 deep	3	X
X ₁ , X ₂	Pilot signal (DA1, DA4)	DIN 2353-CL	8B-ST	40	O
X ₁	Pilot signal (DA2, DA3, DA5, DA6)	DIN 3852 ⁵⁾	M14 x 1.5; 12 deep	40	O
X ₃	Pilot signal (DA2, DA3, DA5, DA6)	DIN 3852 ⁵⁾	M14 x 1.5; 12 deep	40	X
M ₁	Measuring stroking chamber	DIN 3852 ⁵⁾	M14 x 1.5; 12 deep	450	X

- 1) Observe the general instructions on page 80 for the maximum tightening torques.
- 2) Momentary pressure spikes may occur depending on the application. Keep this in mind when selecting measuring devices and fittings.
- 3) Only dimensions according to SAE J518, metric fastening thread is a deviation from standard.
- 4) Depending on installation position, T₁ or T₂ must be connected (see also installation instructions on page 79).
- 5) The spot face can be deeper than specified in the appropriate standard.
- 6) O = Must be connected (plugged on delivery)
X = Plugged (in normal operation)

Dimensions size 160

Before finalizing your design, request a binding installation drawing. Dimensions in mm.

EP.D

Proportional control electric,
with pressure control fixed setting

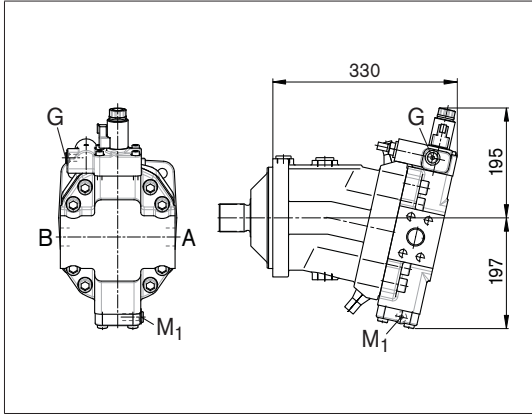

EP.E

Proportional control electric,
with pressure control hydraulic override, two-point

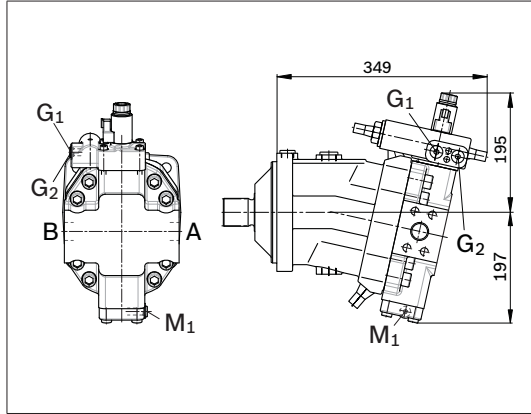

HD1, HD2

Proportional control hydraulic

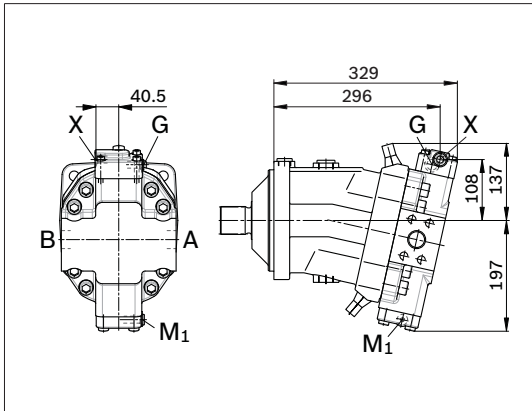

HD.D

Proportional control hydraulic,
with pressure control fixed setting

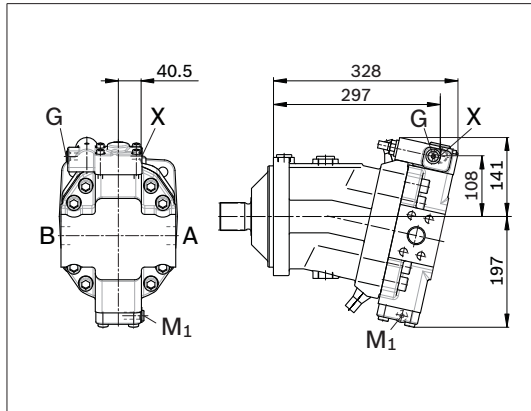

HD.E

Proportional control hydraulic,
with pressure control hydraulic override, two-point

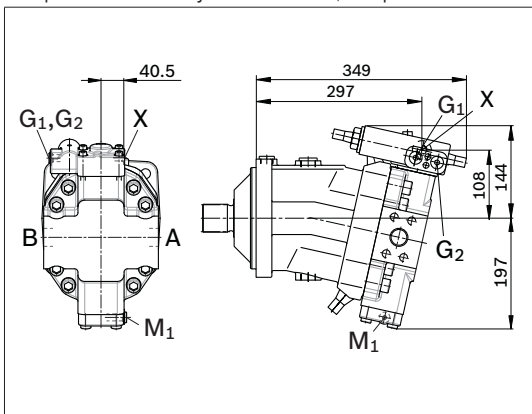

HZ1

Two-point control hydraulic

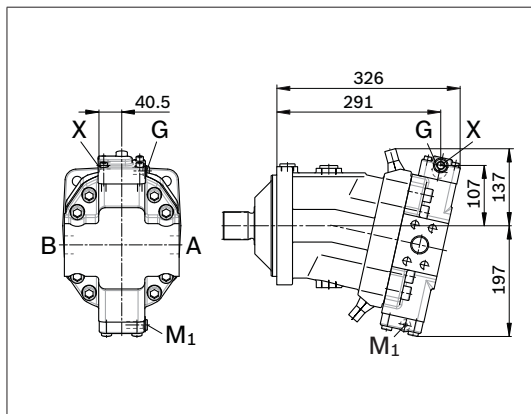

Dimensions size 160

Before finalizing your design, request a binding installation drawing. Dimensions in mm.

EZ1, EZ2

Two-point control electric

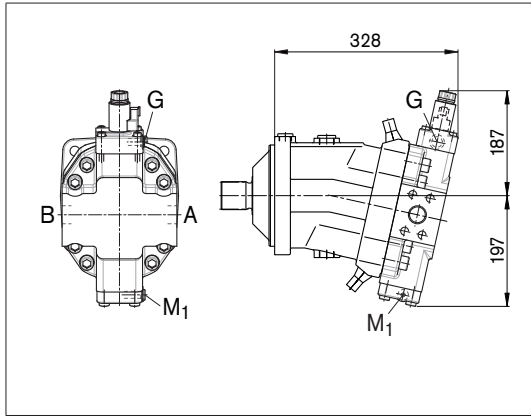

HA1, HA2 / HA1T, HA2T

Automatic control high-pressure related, with override hydraulic remote control, proportional

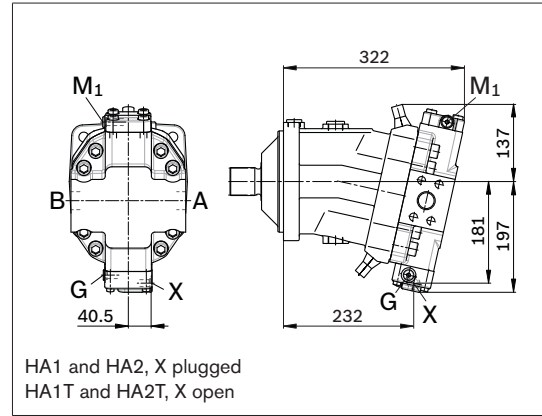

HA1 and HA2, X plugged
HA1T and HA2T, X open

HA1U1, HA2U2

Automatic control high-pressure related, with override electric, two-point

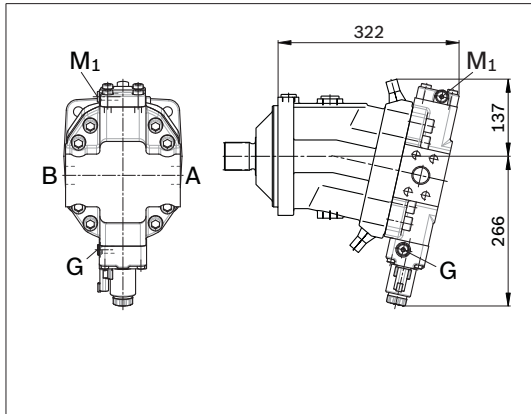

HA1R1, HA2R2

Automatic control high-pressure related, with override electric and travel direction valve electric

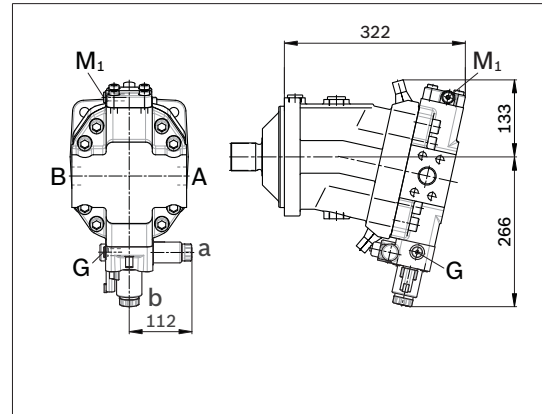

DA1, DA4

Automatic control speed related, with hydraulic travel direction valve

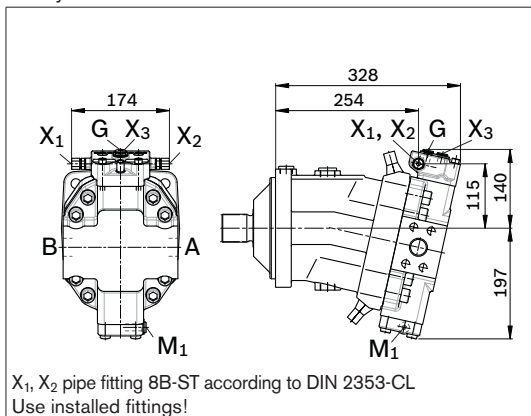

X₁, X₂ pipe fitting 8B-ST according to DIN 2353-CL
Use installed fittings!

DA2, DA3, DA5, DA6

Automatic control speed related, with electric travel direction valve and electric V_{g max}-circuit

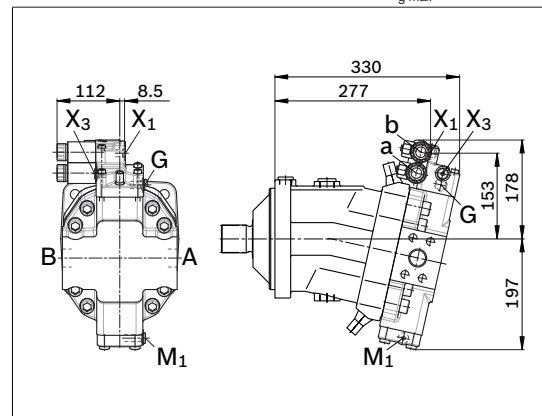

Dimensions size 200

Before finalizing your design, request a binding installation drawing. Dimensions in mm.

EP1, EP2 – Proportional control electric

Port plate 02 – SAE-SAE flange ports A and B at side, opposite

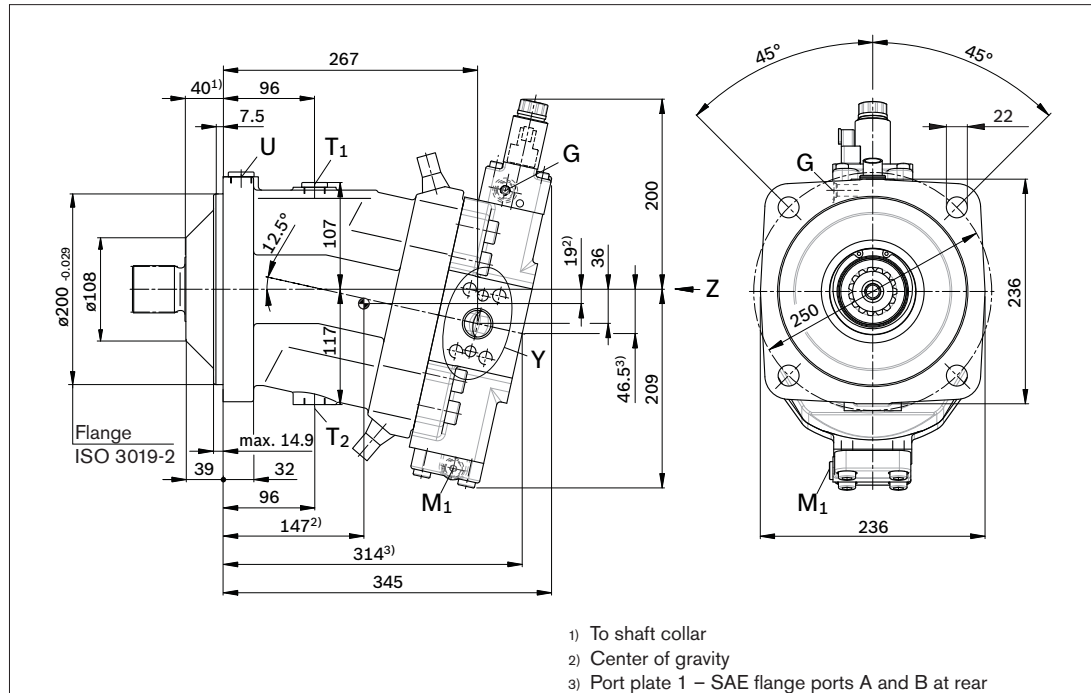

Drive shaft

A Splined shaft DIN 5480
W50x2x24x9g

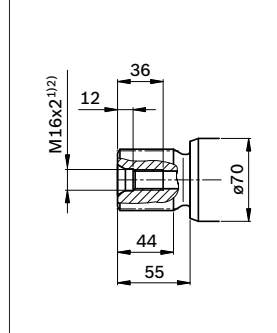

Service line port (detail Y)

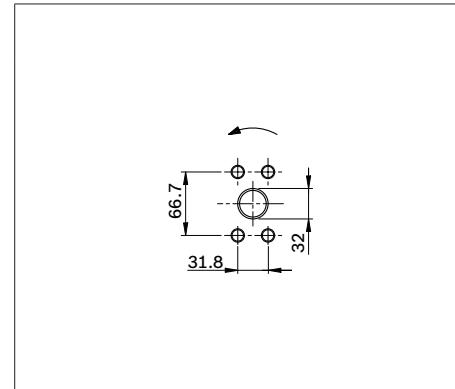

- 1) Observe the general instructions on page 80 for the maximum tightening torques.
- 2) Center bore according to DIN 332 (thread according to DIN 13)

Dimensions size 200

Before finalizing your design, request a binding installation drawing. Dimensions in mm.

Location of the service line ports on the port plates (view Z)

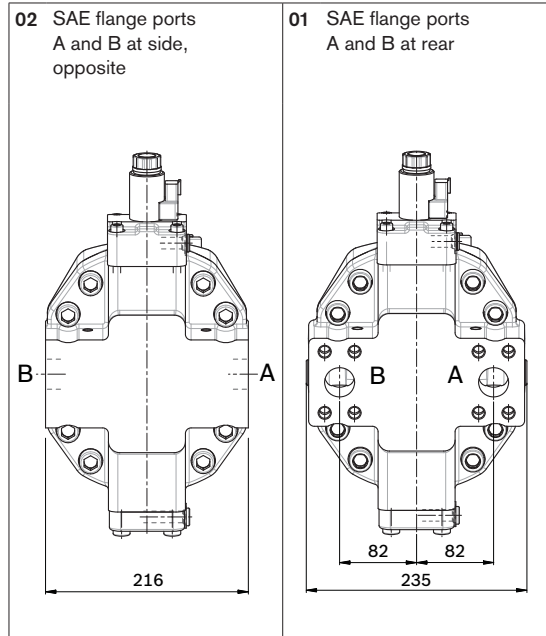

Ports

Designation	Port for	Standard	Size ¹⁾	Maximum pressure [bar] ²⁾	State ⁶⁾
A, B	Service line Fastening thread A/B	SAE J518 ³⁾ DIN 13	1 1/4 in M14 x 2; 19 deep	450	O
T ₁	Drain line	DIN 3852 ⁵⁾	M26 x 1.5; 16 deep	3	X ⁴⁾
T ₂	Drain line	DIN 3852 ⁵⁾	M26 x 1.5; 16 deep	3	O ⁴⁾
G	Synchronous control	DIN 3852 ⁵⁾	M14 x 1.5; 12 deep	450	X
G ₂	2nd pressure setting (HD,E, EPE)	DIN 3852 ⁵⁾	M14 x 1.5; 12 deep	100	X
U	Bearing flushing	DIN 3852 ⁵⁾	M22 x 1.5; 14 deep	3	X
X	Pilot signal (HD, HZ, HA1T/HA2T)	DIN 3852 ⁵⁾	M14 x 1.5; 12 deep	100	O
X	Pilot signal (HA1 and HA2)	DIN 3852 ⁵⁾	M14 x 1.5; 12 deep	3	X
X ₁ , X ₂	Pilot signal (DA1, DA4)	DIN 2353-CL	8B-ST	40	O
X ₁	Pilot signal (DA2, DA3, DA5, DA6)	DIN 3852 ⁵⁾	M14 x 1.5; 12 deep	40	O
X ₃	Pilot signal (DA2, DA3, DA5, DA6)	DIN 3852 ⁵⁾	M14 x 1.5; 12 deep	40	X
M ₁	Measuring stroking chamber	DIN 3852 ⁵⁾	M14 x 1.5; 12 deep	450	X

- 1) Observe the general instructions on page 80 for the maximum tightening torques.
- 2) Momentary pressure spikes may occur depending on the application. Keep this in mind when selecting measuring devices and fittings.
- 3) Only dimensions according to SAE J518, metric fastening thread is a deviation from standard.
- 4) Depending on installation position, T₁ or T₂ must be connected (see also installation instructions on page 79).
- 5) The spot face can be deeper than specified in the appropriate standard.
- 6) O = Must be connected (plugged on delivery)
X = Plugged (in normal operation)

Dimensions size 200

Before finalizing your design, request a binding installation drawing. Dimensions in mm.

EP.D

Proportional control electric,
with pressure control fixed setting

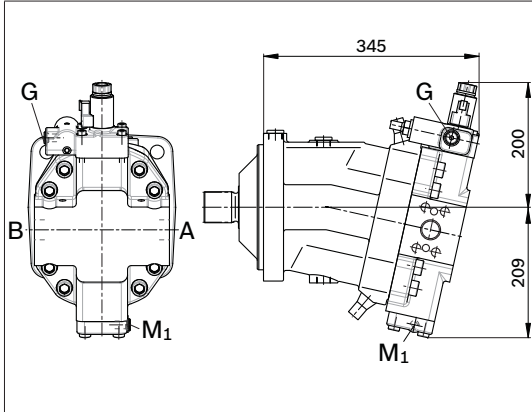

EP.E

Proportional control electric,
with pressure control hydraulic override, two-point

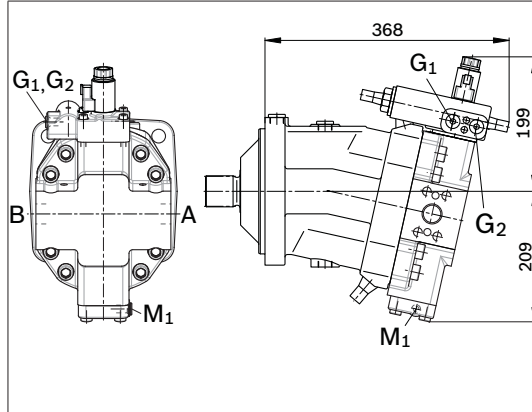

HD1, HD2

Proportional control hydraulic

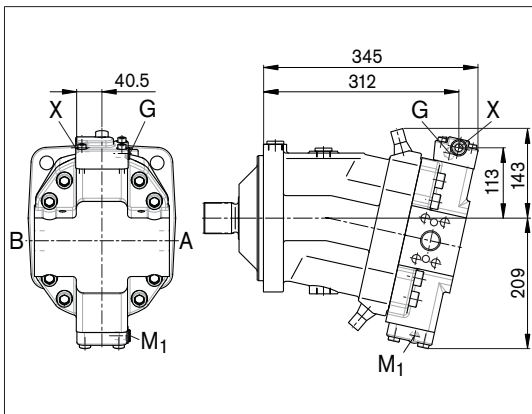

HD.D

Proportional control hydraulic,
with pressure control fixed setting

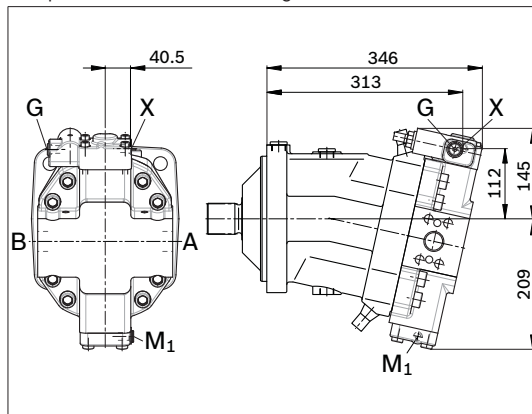

HD.E

Proportional control hydraulic,
with pressure control hydraulic override, two-point

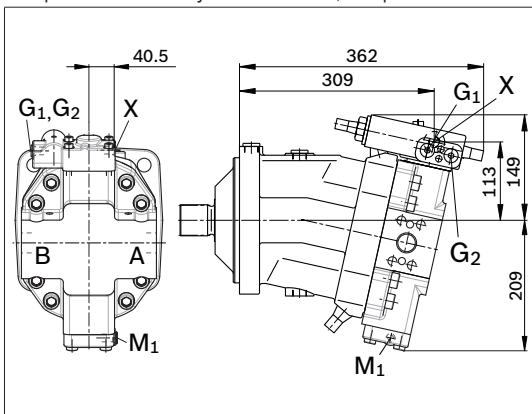

HZ1

Two-point control hydraulic

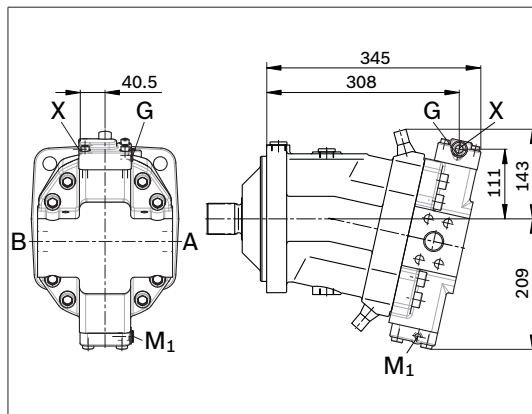

Dimensions size 200

Before finalizing your design, request a binding installation drawing. Dimensions in mm.

EZ1, EZ2

Two-point control electric

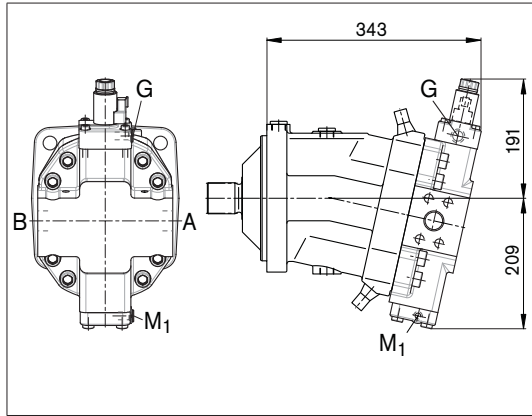

HA1, HA2 / HA1T, HA2T

Automatic control high-pressure related,
with override hydraulic remote control, proportional

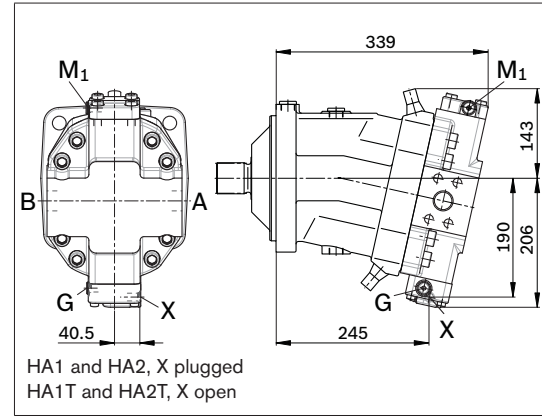

HA1U1, HA2U2

Automatic control high-pressure related,
with override electric, two-point

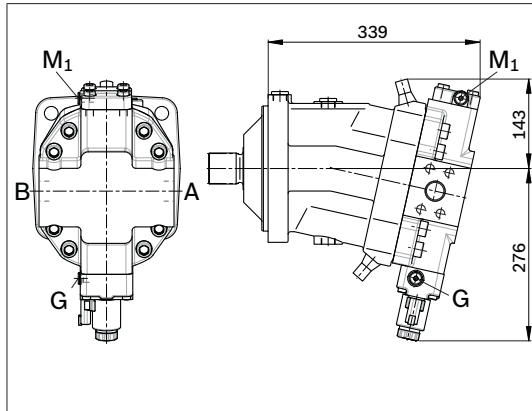

HA1R1, HA2R2

Automatic control high-pressure related,
with override electric and travel direction valve electric

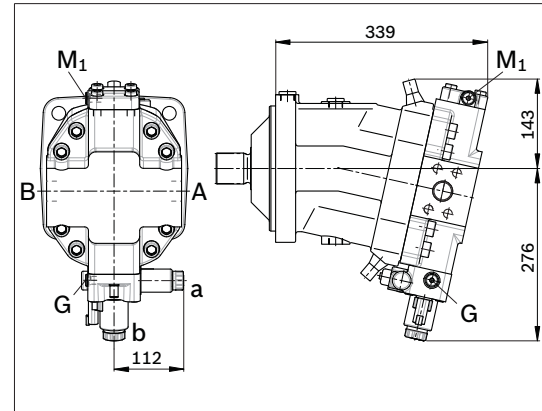

DA1, DA4

Automatic control speed related,
with hydraulic travel direction valve

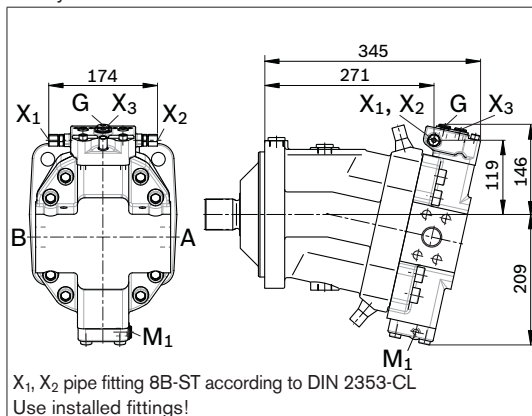

DA2, DA3, DA5, DA6

Automatic control speed related,
with electric travel direction valve and electric V_{g max}-circuit

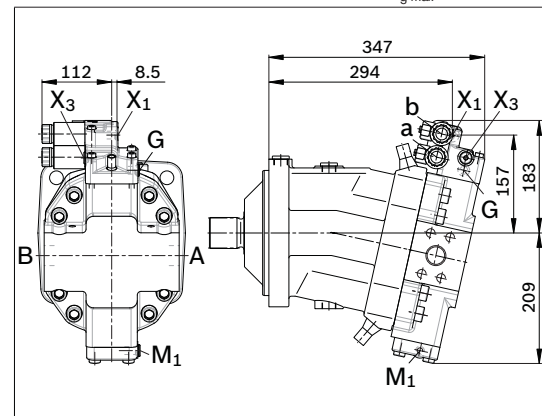

Dimensions size 250

Before finalizing your design, request a binding installation drawing. Dimensions in mm.

HD1, HD2 – Proportional control hydraulic

HZ – Two-point control hydraulic

Port plate 02 – SAE flange ports A and B at side, opposite

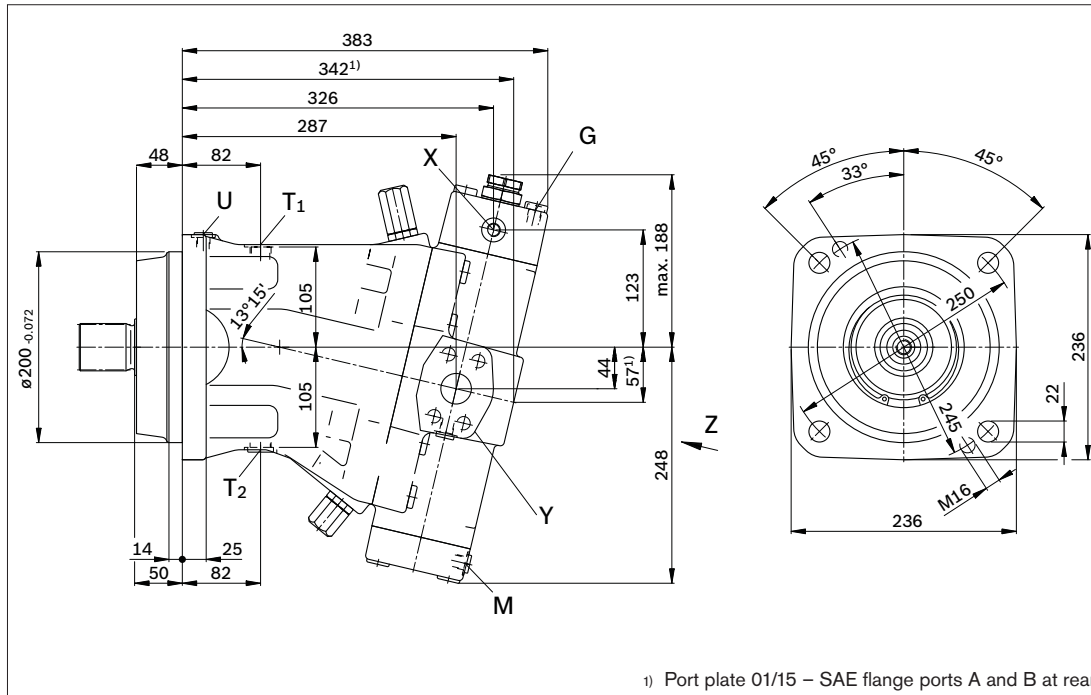

Drive shafts

Z Splined shaft DIN 5480
W50x2x24x9g

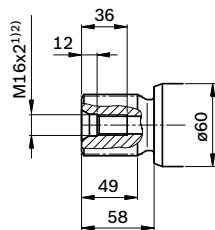

P Cyl. shaft with key
AS14x9x80
(DIN 6885)

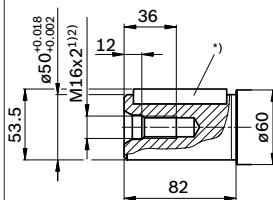

¹⁾ Key width 14

Service line port (detail Y)

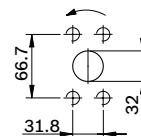

- 1) Observe the general instructions on page 80 for the maximum tightening torques.
- 2) Center bore according to DIN 332 (thread according to DIN 13)

Dimensions size 250

Before finalizing your design, request a binding installation drawing. Dimensions in mm.

Location of the service line ports on the port plates (view Z)

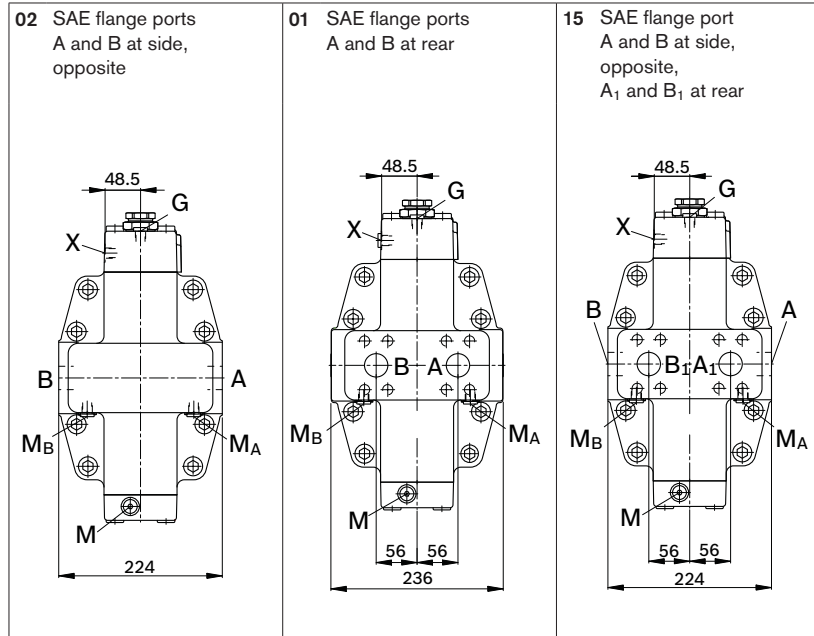

Ports

Designation	Port for	Standard	Size ¹⁾	Maximum pressure [bar] ²⁾	State ⁶⁾
A, B	Service line Fastening thread A/B	SAE J518 ³⁾ DIN 13	1 1/4 in M14 x 2; 19 deep	400	O
A ₁ , B ₁	Additional service line for plate 15 Fastening thread A ₁ /B ₁	SAE J518 ³⁾ DIN 13	1 1/4 in M14 x 2; 19 deep	400	O
T ₁	Drain line	DIN 3852 ⁵⁾	M22 x 1.5; 14 deep	3	X ⁴⁾
T ₂	Drain line	DIN 3852 ⁵⁾	M22 x 1.5; 14 deep	3	O ⁴⁾
G	Synchronous control	DIN 3852 ⁵⁾	M14 x 1.5; 12 deep	400	X
G ₂	2nd pressure setting (HD.D, EP.D)	DIN 3852 ⁵⁾	M14 x 1.5; 12 deep	400	X
P	Pilot oil supply (EP)	DIN 3852 ⁵⁾	M14 x 1.5; 12 deep	100	O
U	Bearing flushing	DIN 3852 ⁵⁾	M14 x 1.5; 12 deep	3	X
X	Pilot signal (HD, HZ, HA1T/HA2T)	DIN 3852 ⁵⁾	M14 x 1.5; 12 deep	100	O
X	Pilot signal (HA1 and HA2)	DIN 3852 ⁵⁾	M14 x 1.5; 12 deep	3	X
X ₁ , X ₂	Pilot signal (DA)	DIN 2353-CL	8B-ST	40	O
X ₃	Remote control valve (HD.G, EP.G)	DIN 3852 ⁵⁾	M14 x 1.5; 12 deep	400	O
M	Measuring stroking chamber	DIN 3852 ⁵⁾	M14 x 1.5; 12 deep	400	X
M _A , M _B	Measuring pressure A/B	DIN 3852 ⁵⁾	M14 x 1.5; 12 deep	400	X
M _{St}	Measuring pilot pressure	DIN 3852 ⁵⁾	M14 x 1.5; 12 deep	400	X

- 1) Observe the general instructions on page 80 for the maximum tightening torques.
- 2) Momentary pressure spikes may occur depending on the application. Keep this in mind when selecting measuring devices and fittings.
- 3) Only dimensions according to SAE J518, metric fastening thread is a deviation from standard.
- 4) Depending on installation position, T₁ or T₂ must be connected (see also installation instructions on page 79).
- 5) The spot face can be deeper than specified in the appropriate standard.
- 6) O = Must be connected (plugged on delivery)
X = Plugged (in normal operation)

Dimensions size 250

Before finalizing your design, request a binding installation drawing. Dimensions in mm.

EP1, EP2

Proportional control electric

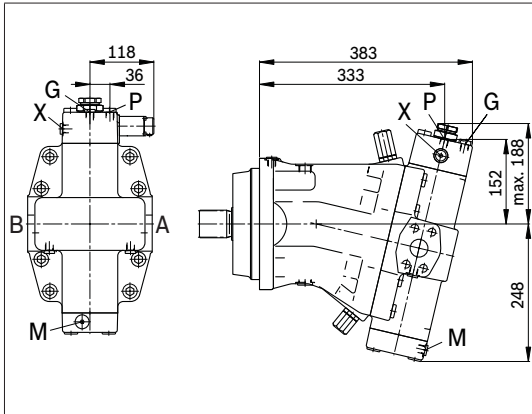

EP.D, EP.G

Proportional control electric,
with pressure control fixed setting; remote control (EP.G)

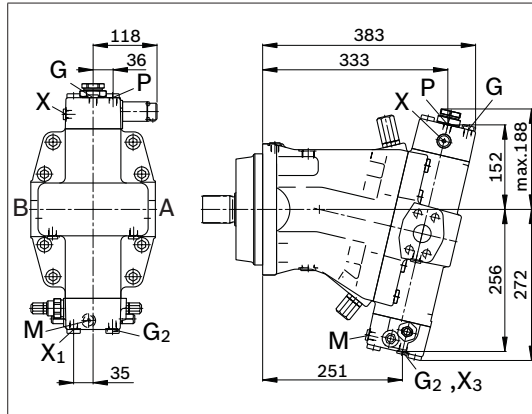

HD.D, HD.G

Proportional control hydraulic,
with pressure control fixed setting; remote control (EP.G)

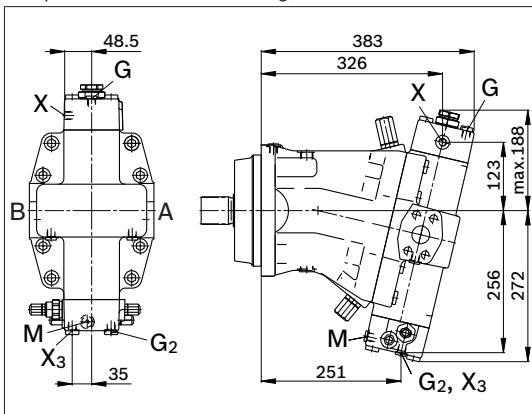

EZ1, EZ2

Two-point control electric

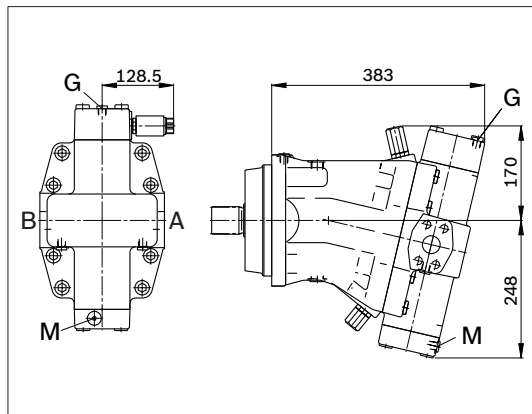

HA1, HA2 / HA1T, HA2T

Automatic control high-pressure related,
with override hydraulic remote control, proportional

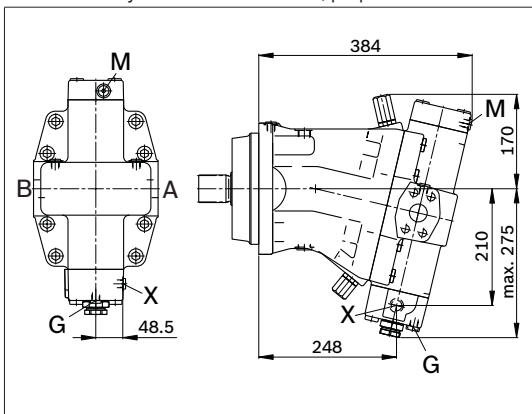

DA

Automatic control speed related,
with hydraulic travel direction valve

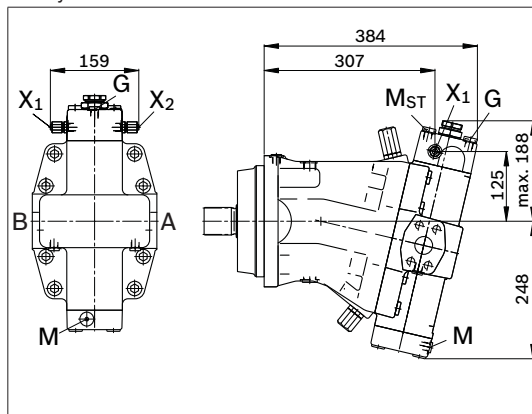

Dimensions size 355

Before finalizing your design, request a binding installation drawing. Dimensions in mm.

HD1, HD2 – Proportional control hydraulic
HZ – Two-point control hydraulic

Port plate 02 – SAE flange ports A and B at side, opposite

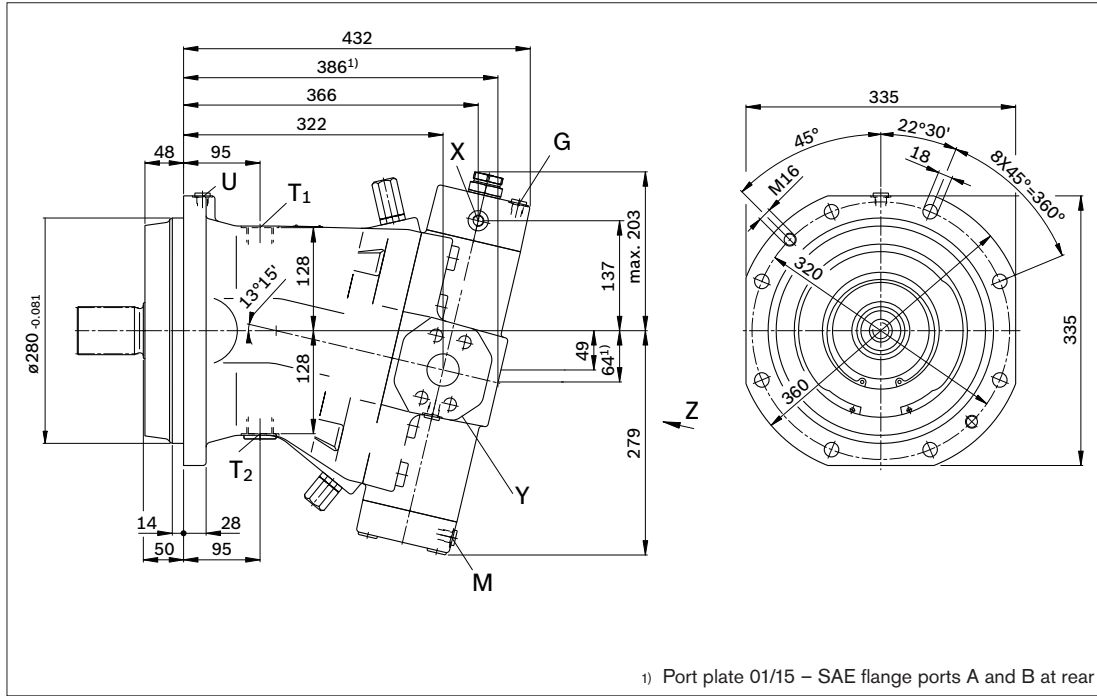

1) Port plate 01/15 – SAE flange ports A and B at rear

Drive shafts

Z Splined shaft DIN 5480
W60x2x28x9g

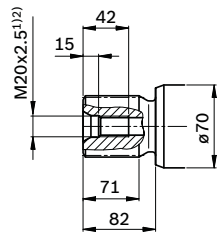

P Cyl. shaft with key
AS18x11x100
(DIN 6885)

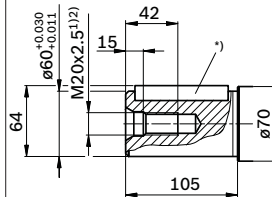

*) Key width 18

Service line port (detail Y)

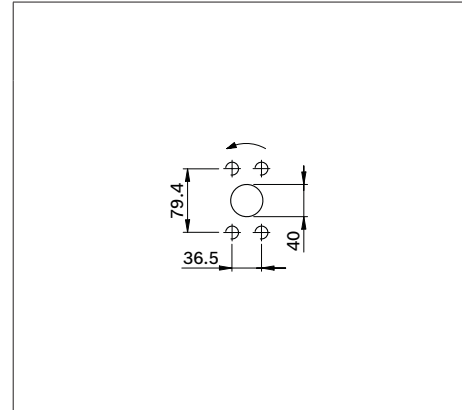

- 1) Observe the general instructions on page 80 for the maximum tightening torques.
- 2) Center bore according to DIN 332 (thread according to DIN 13)

Dimensions size 355

Before finalizing your design, request a binding installation drawing. Dimensions in mm.

Location of the service line ports on the port plates (view Z)

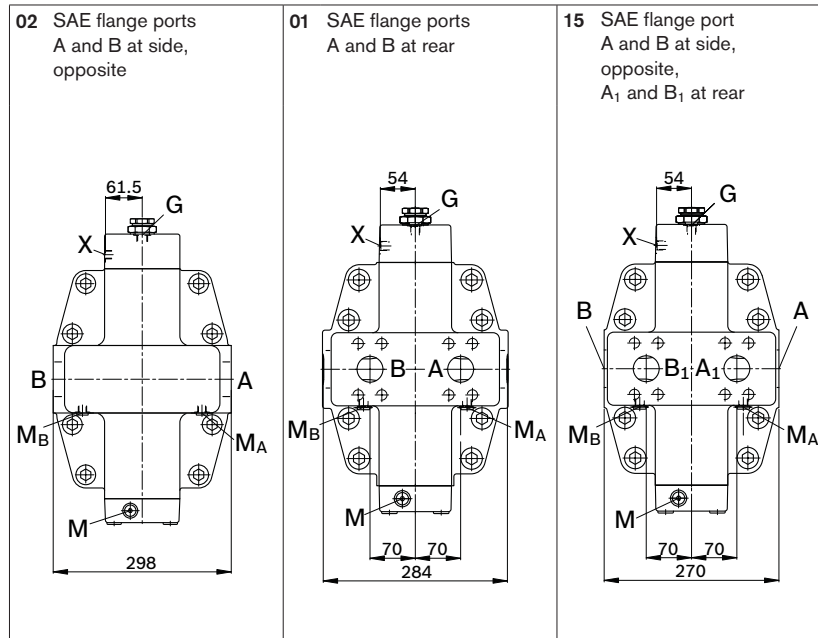

Ports

Designation	Port for	Standard	Size ¹⁾	Maximum pressure [bar] ²⁾	State ⁶⁾
A, B	Service line Fastening thread A/B	SAE J518 ³⁾ DIN 13	1 1/2 in M16 x 2; 24 deep	400	O
A ₁ , B ₁	Additional service line for plate 15 Fastening thread A ₁ /B ₁	SAE J518 ³⁾ DIN 13	1 1/2 in M16 x 2; 24 deep	400	O
T ₁	Drain line	DIN 3852 ⁵⁾	M33 x 2; 18 deep	3	X ⁴⁾
T ₂	Drain line	DIN 3852 ⁵⁾	M33 x 2; 18 deep	3	O ⁴⁾
G	Synchronous control	DIN 3852 ⁵⁾	M14 x 1.5; 12 deep	400	X
G ₂	2nd pressure setting (HD.D, EP.D)	DIN 3852 ⁵⁾	M14 x 1.5; 12 deep	400	X
P	Pilot oil supply (EP)	DIN 3852 ⁵⁾	M14 x 1.5; 12 deep	100	O
U	Bearing flushing	DIN 3852 ⁵⁾	M14 x 1.5; 12 deep	3	X
X	Pilot signal (HD, HZ, HA1T/HA2T)	DIN 3852 ⁵⁾	M14 x 1.5; 12 deep	100	O
X	Pilot signal (HA1 and HA2)	DIN 3852 ⁵⁾	M14 x 1.5; 12 deep	3	X
X ₁ , X ₂	Pilot signal (DA)	DIN 2353-CL	8B-ST	40	O
X ₃	Remote control valve (HD.G, EP.G)	DIN 3852 ⁵⁾	M14 x 1.5; 12 deep	400	O
M	Measuring stroking chamber	DIN 3852 ⁵⁾	M14 x 1.5; 12 deep	400	X
M _A , M _B	Measuring pressure A/B	DIN 3852 ⁵⁾	M14 x 1.5; 12 deep	400	X
M _{St}	Measuring pilot pressure	DIN 3852 ⁵⁾	M14 x 1.5; 12 deep	400	X

- Observe the general instructions on page 80 for the maximum tightening torques.
- Momentary pressure spikes may occur depending on the application. Keep this in mind when selecting measuring devices and fittings.
- Only dimensions according to SAE J518, metric fastening thread is a deviation from standard.
- Depending on installation position, T₁ or T₂ must be connected (see also installation instructions on page 79).
- The spot face can be deeper than specified in the appropriate standard.
- O = Must be connected (plugged on delivery)
X = Plugged (in normal operation)

Dimensions size 355

Before finalizing your design, request a binding installation drawing. Dimensions in mm.

EP1, EP2

Proportional control electric

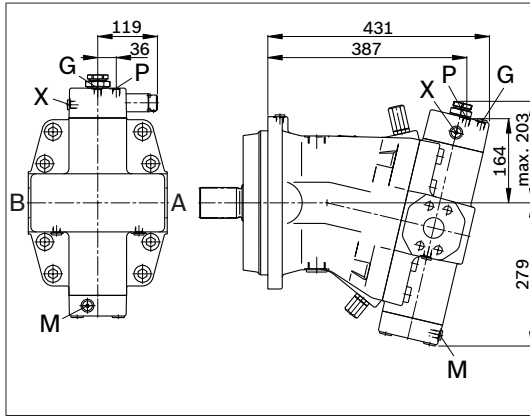

EP.D, EP.G

Proportional control electric,
with pressure control fixed setting; remote control (EP.G)

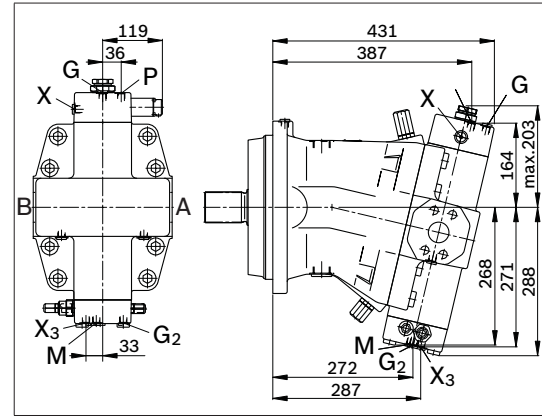

HD.D, HD.G

Proportional control hydraulic,
with pressure control fixed setting; remote control (EP.G)

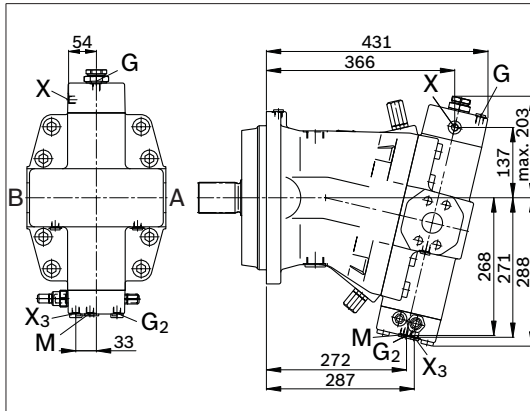

EZ1, EZ2

Two-point control electric

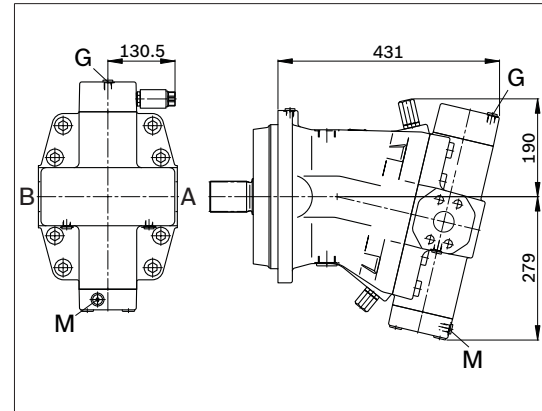

HA1, HA2 / HA1T, HA2T

Automatic control high-pressure related,
with override hydraulic remote control, proportional

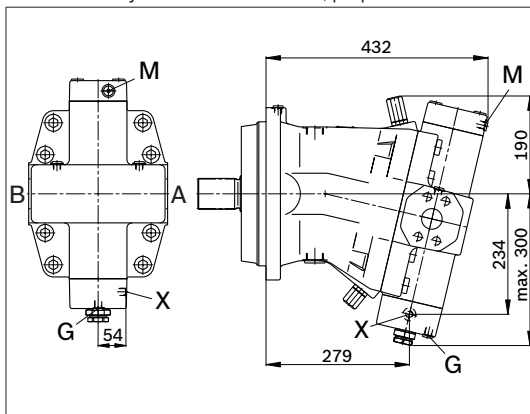

DA

Automatic control speed related,
with hydraulic travel direction valve

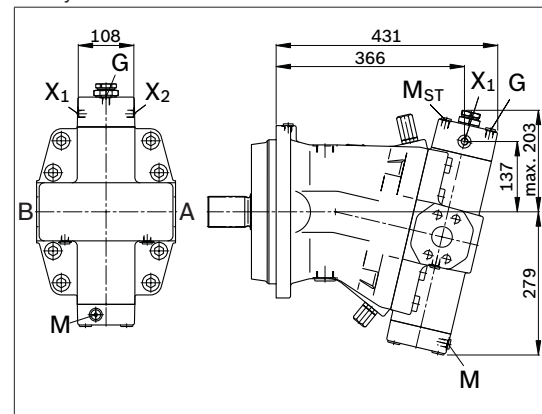

Dimensions size 500

Before finalizing your design, request a binding installation drawing. Dimensions in mm.

Location of the service line ports on the port plates (view Z)

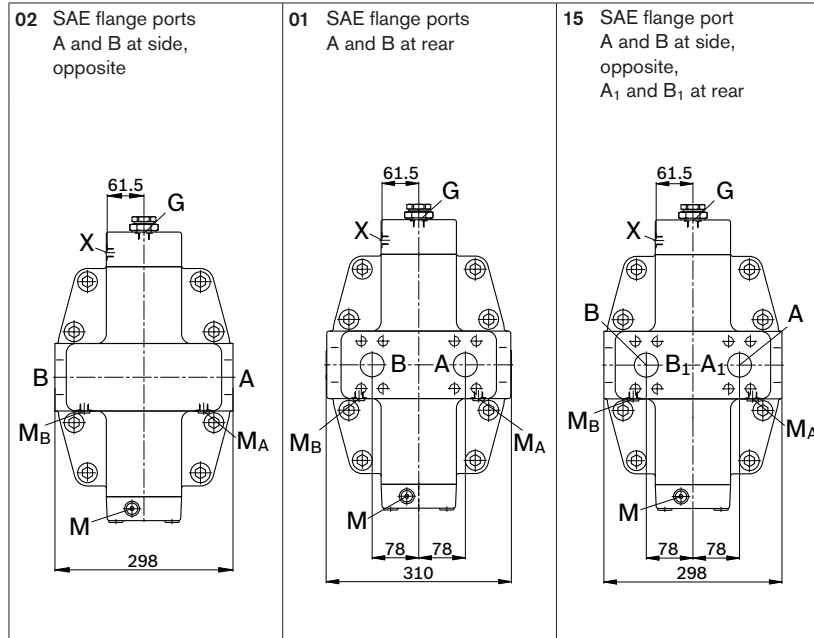

Ports

Designation	Port for	Standard	Size ¹⁾	Maximum pressure [bar] ²⁾	State ⁶⁾
A, B	Service line Fastening thread A/B	SAE J518 ³⁾ DIN 13	1 1/2 in M16 x 2; 24 deep	400	O
A ₁ , B ₁	Additional service line for plate 15 Fastening thread A ₁ /B ₁	SAE J518 ³⁾ DIN 13	1 1/2 in M16 x 2; 24 deep	400	O
T ₁	Drain line	DIN 3852 ⁵⁾	M33 x 2; 18 deep	3	X ⁴⁾
T ₂	Drain line	DIN 3852 ⁵⁾	M33 x 2; 18 deep	3	O ⁴⁾
G	Synchronous control	DIN 3852 ⁵⁾	M18 x 1.5; 12 deep	400	X
G ₂	2nd pressure setting (HD.D, EP.D)	DIN 3852 ⁵⁾	M18 x 1.5; 12 deep	400	X
P	Pilot oil supply (EP)	DIN 3852 ⁵⁾	M14 x 1.5; 12 deep	100	O
U	Bearing flushing	DIN 3852 ⁵⁾	M18 x 1.5; 12 deep	3	X
X	Pilot signal (HD, HZ, HA1T/HA2T)	DIN 3852 ⁵⁾	M14 x 1.5; 12 deep	100	O
X	Pilot signal (HA1 and HA2)	DIN 3852 ⁵⁾	M14 x 1.5; 12 deep	3	X
X ₁ , X ₂	Pilot signal (DA)	DIN 2353-CL	8B-ST	40	O
X ₃	Remote control valve (HD.G, EP.G)	DIN 3852 ⁵⁾	M14 x 1.5; 12 deep	400	O
M	Measuring stroking chamber	DIN 3852 ⁵⁾	M14 x 1.5; 12 deep	400	X
M _A , M _B	Measuring pressure A/B	DIN 3852 ⁵⁾	M14 x 1.5; 12 deep	400	X
M _{St}	Measuring pilot pressure	DIN 3852 ⁵⁾	M14 x 1.5; 12 deep	400	X

- 1) Observe the general instructions on page 80 for the maximum tightening torques.
- 2) Momentary pressure spikes may occur depending on the application. Keep this in mind when selecting measuring devices and fittings.
- 3) Only dimensions according to SAE J518, metric fastening thread is a deviation from standard.
- 4) Depending on installation position, T₁ or T₂ must be connected (see also installation instructions on page 79).
- 5) The spot face can be deeper than specified in the appropriate standard.
- 6) O = Must be connected (plugged on delivery)
X = Plugged (in normal operation)

Dimensions size 500

Before finalizing your design, request a binding installation drawing. Dimensions in mm.

EP1, EP2

Proportional control electric

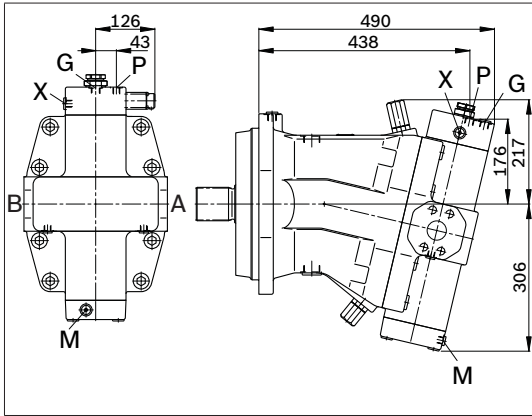

EP.D, EP.G

Proportional control electric,
with pressure control fixed setting; remote control (EP.G)

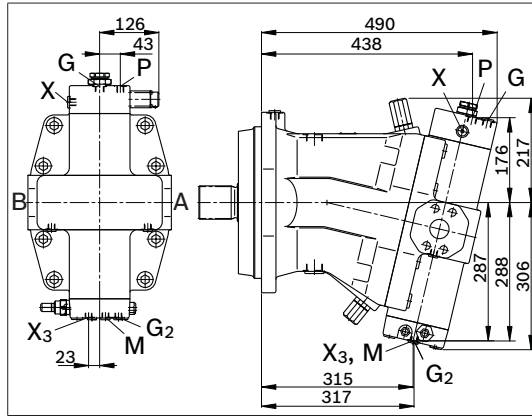

HD.D, HD.G

Proportional control hydraulic,
with pressure control fixed setting; remote control (EP.G)

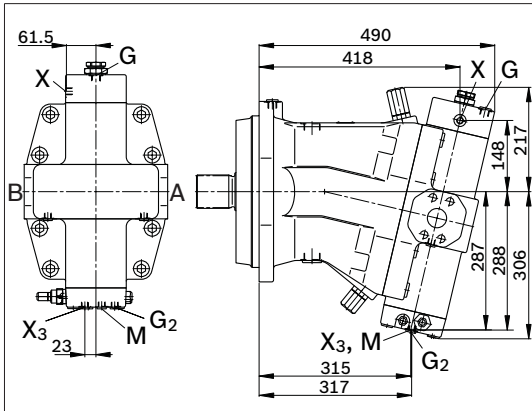

EZ1, EZ2

Two-point control electric

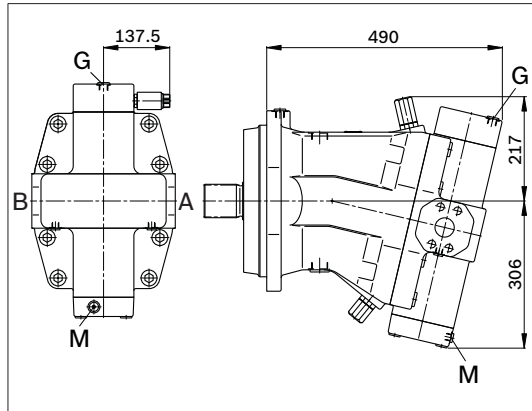

HA1, HA2 / HA1T, HA2T

Automatic control high-pressure related,
with override hydraulic remote control, proportional

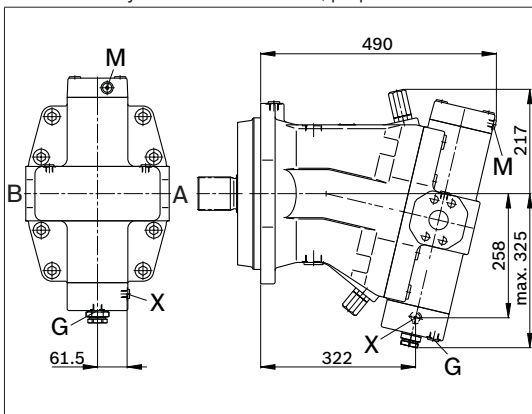

DA

Automatic control speed related,
with hydraulic travel direction valve

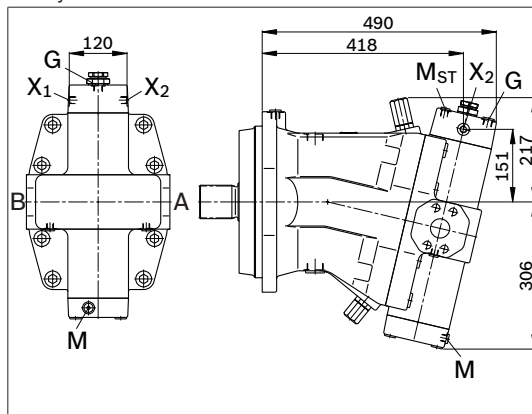

Dimensions size 1000

Before finalizing your design, request a binding installation drawing. Dimensions in mm.

HD1, HD2 – Proportional control hydraulic
HZ – Two-point control hydraulic

Port plate 02 – SAE- SAE flange ports A and B at side, opposite

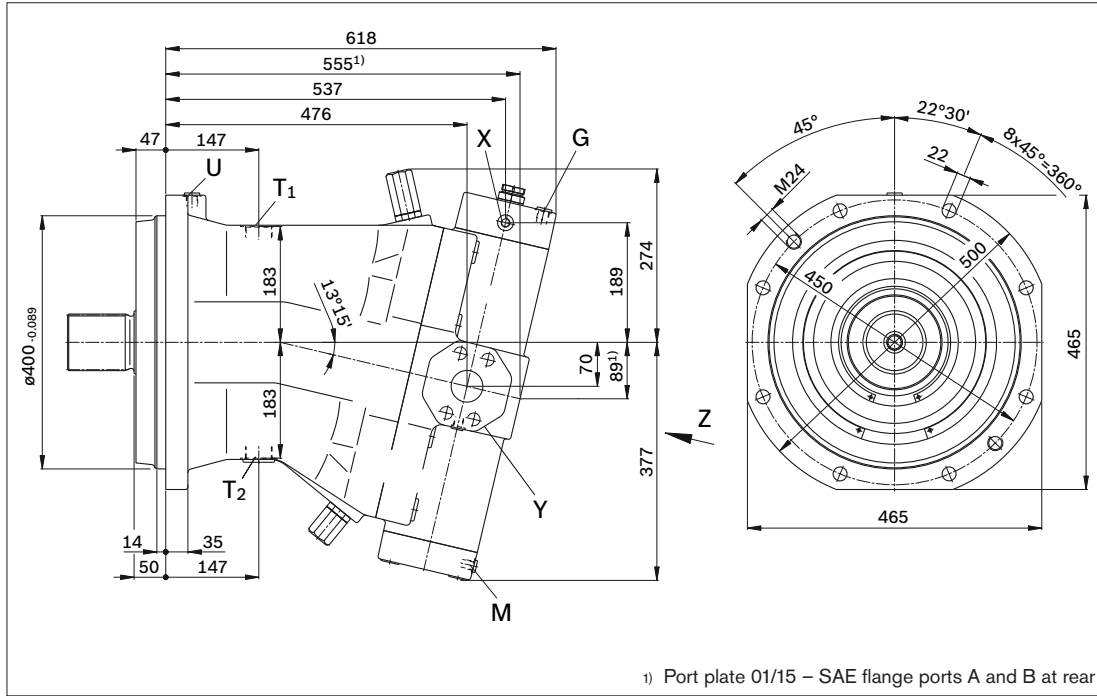

1) Port plate 01/15 – SAE flange ports A and B at rear

Drive shafts

A Splined shaft DIN 5480
W90x3x28x9g

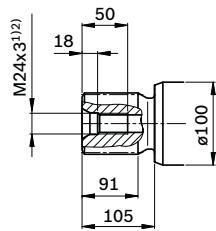

P Cyl. shaft with key
AS25x14x125
(DIN 6885)

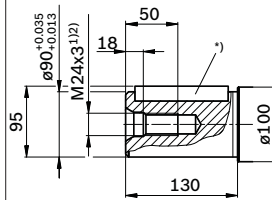

¹⁾ Key width 25

Service line port (detail Y)

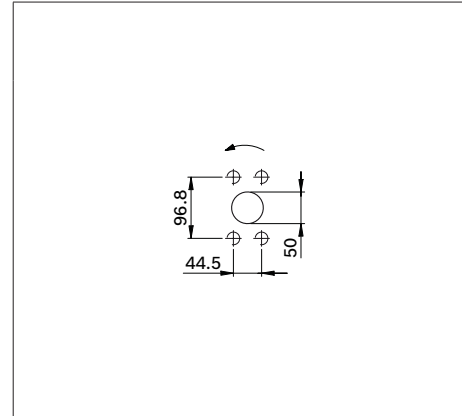

- 1) Observe the general instructions on page 80 for the maximum tightening torques.
- 2) Center bore according to DIN 332 (thread according to DIN 13)

Dimensions size 1000

Before finalizing your design, request a binding installation drawing. Dimensions in mm.

Location of the service line ports on the port plates (view Z)

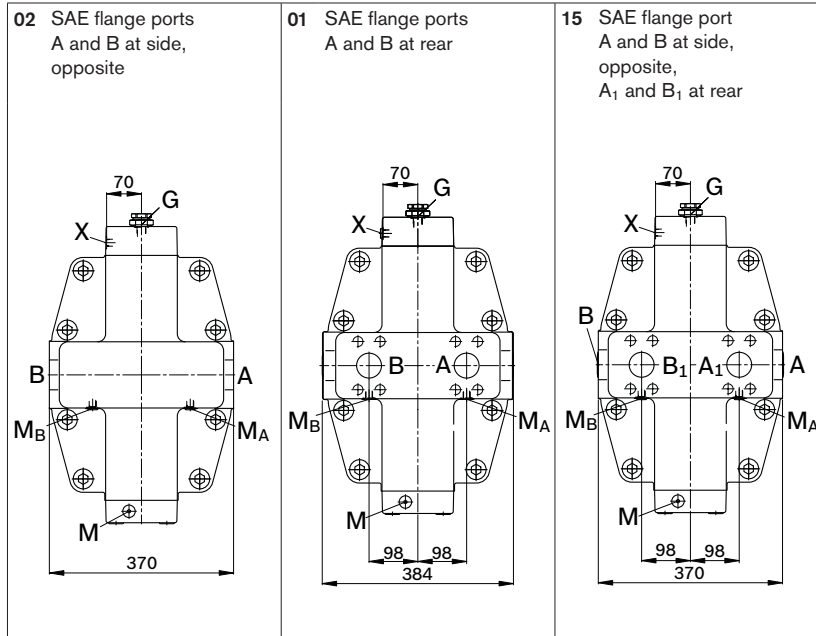

Ports

Designation	Port for	Standard	Size ¹⁾	Maximum pressure [bar] ²⁾	State ⁶⁾
A, B	Service line Fastening thread A/B	SAE J518 ³⁾ DIN 13	2 in M20 x 2.5; 24 deep	400	O
A ₁ , B ₁	Additional service line for plate 15 Fastening thread A ₁ /B ₁	SAE J518 ³⁾ DIN 13	2 in M20 x 2.5; 24 deep	400	O
T ₁	Drain line	DIN 3852 ⁵⁾	M42 x 2; 20 deep	3	X ⁴⁾
T ₂	Drain line	DIN 3852 ⁵⁾	M42 x 2; 20 deep	3	O ⁴⁾
G	Synchronous control	DIN 3852 ⁵⁾	M18 x 1.5; 12 deep	400	X
G ₂	2nd pressure setting (HD.D, EP.D)	DIN 3852 ⁵⁾	M18 x 1.5; 12 deep	400	X
P	Pilot oil supply (EP)	DIN 3852 ⁵⁾	M14 x 1.5; 12 deep	100	O
U	Bearing flushing	DIN 3852 ⁵⁾	M18 x 1.5; 12 deep	3	X
X	Pilot signal (HD, HZ, HA1T/HA2T)	DIN 3852 ⁵⁾	M14 x 1.5; 12 deep	100	O
X	Pilot signal (HA1 and HA2)	DIN 3852 ⁵⁾	M14 x 1.5; 12 deep	3	X
X ₃	Remote control valve (HD.G, EP.G)	DIN 3852 ⁵⁾	M14 x 1.5; 12 deep	400	O
M	Measuring stroking chamber	DIN 3852 ⁵⁾	M14 x 1.5; 12 deep	400	X
M _A , M _B	Measuring pressure A/B	DIN 3852 ⁵⁾	M14 x 1.5; 12 deep	400	X
M _{St}	Measuring pilot pressure	DIN 3852 ⁵⁾	M14 x 1.5; 12 deep	400	X

- 1) Observe the general instructions on page 80 for the maximum tightening torques.
- 2) Momentary pressure spikes may occur depending on the application. Keep this in mind when selecting measuring devices and fittings.
- 3) Only dimensions according to SAE J518, metric fastening thread is a deviation from standard.
- 4) Depending on installation position, T₁ or T₂ must be connected (see also installation instructions on page 79).
- 5) The spot face can be deeper than specified in the appropriate standard.
- 6) O = Must be connected (plugged on delivery)
X = Plugged (in normal operation)

Dimensions size 1000

Before finalizing your design, request a binding installation drawing. Dimensions in mm.

EP1, EP2

Proportional control electric

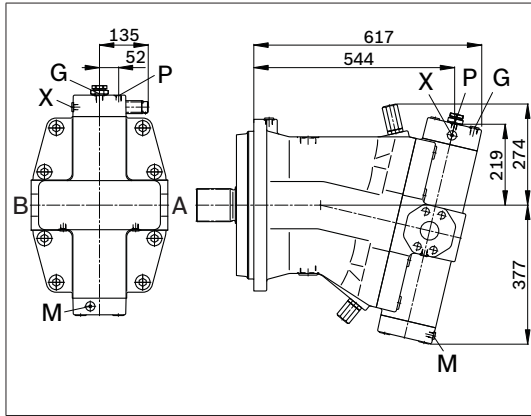

EP.D, EP.G

Proportional control electric,
with pressure control fixed setting; remote control (EP.G)

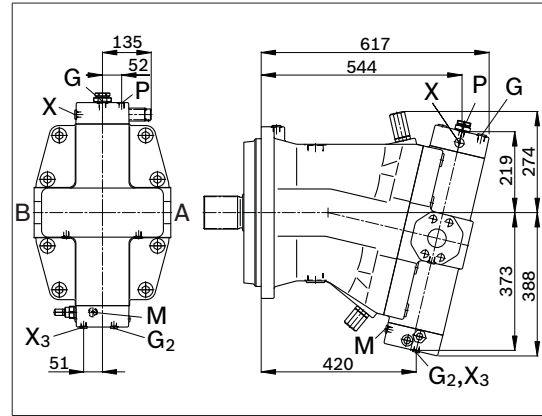

HD.D, HD.G

Proportional control hydraulic,
with pressure control fixed setting; remote control (EP.G)

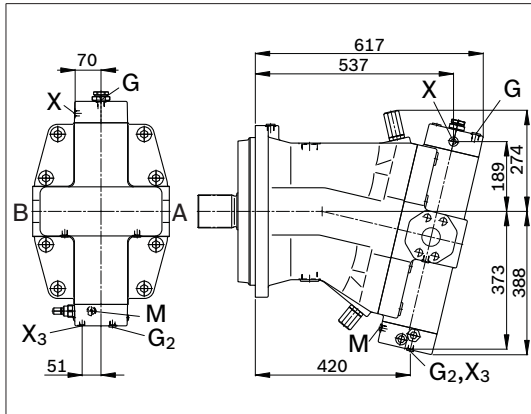

EZ1, EZ2

Two-point control electric

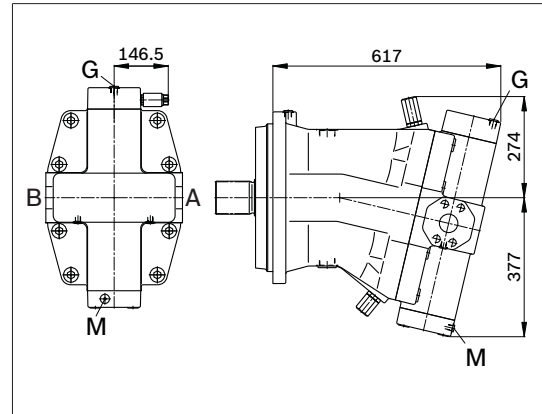

HA1, HA2 / HA1T, HA2T

Automatic control high-pressure related,
with override hydraulic remote control, proportional

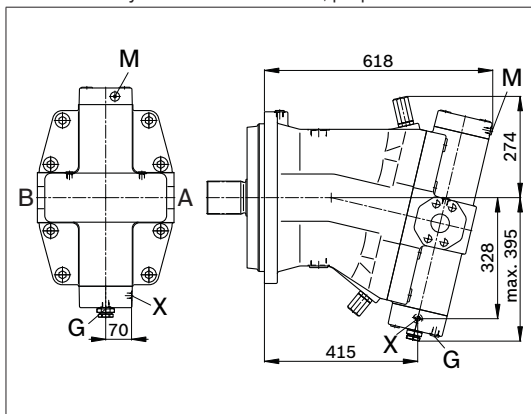

Flushing and boost pressure valve

The flushing and boost pressure valve is used to remove heat from the hydraulic circuit.

In an open circuit, it is used only for flushing the housing.

In a closed circuit, it ensures a minimum boost pressure level in addition to the case flushing.

Hydraulic fluid is directed from the respective low pressure side into the motor housing. This is then fed into the reservoir, together with the case drain fluid. The hydraulic fluid, removed out of the closed circuit must be replaced by cooled hydraulic fluid from the boost pump.

The valve is mounted onto the port plate or integrated (depending on the control type and size).

Cracking pressure of pressure retaining valve

(observe when setting the primary valve)

fixed setting _____ 16 bar

Switching pressure of flushing piston Δp _____ 8 ± 1 bar

Flushing flow q_v

Orifices can be used to set the flushing flows as required.

Following parameters are based on:

$\Delta p_{ND} = p_{ND} - p_G = 25$ bar and $v = 10$ mm²/s

(p_{ND} = low pressure, p_G = case pressure)

Size	Flushing flow q_v [L/min]	Mat. No. of orifice
28, 55	3.5	R909651766
80	5	R909419695
107	8	R909419696
140, 160, 200	10	R909419697
250	10	R909419697
355, 500, 1000	16	R910803019

With sizes 28 to 200, orifices can be supplied for flushing flows from 3.5 to - 10 L/min. For other flushing flows, please state the required flushing flow when ordering. The flushing flow without orifice is approx. 12 to 14 L at low pressure $\Delta p_{ND} = 25$ bar.

Schematic EP

Sizes 28 to 200

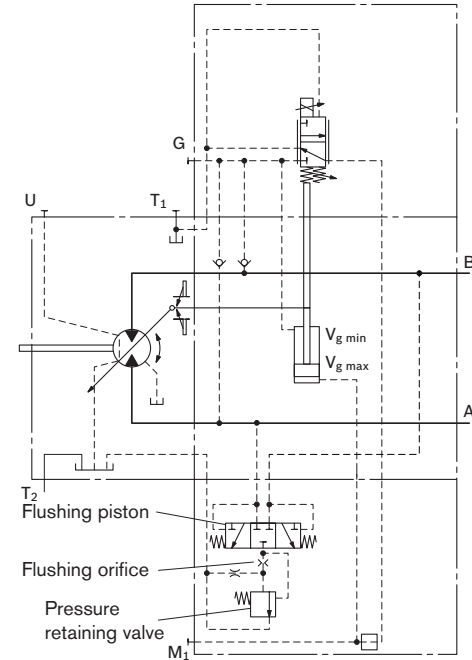

Schematic

Sizes 250 to 1000

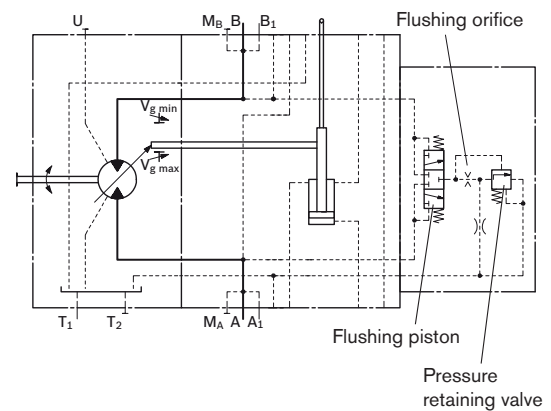

Flushing and boost pressure valve

Before finalizing your design, request a binding installation drawing. Dimensions in mm.

Dimensions

Sizes 28 to 200

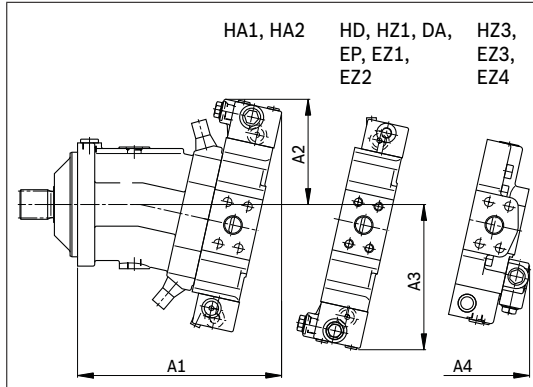

NG	A1	A2	A3	A4
28	214	125	161	–
55	243	133	176	236
80	273	142	193	254
107	288	144	200	269
140	321	154	218	–
160	328	154	220	–
200	345	160	231	–

Sizes 250 to 1000

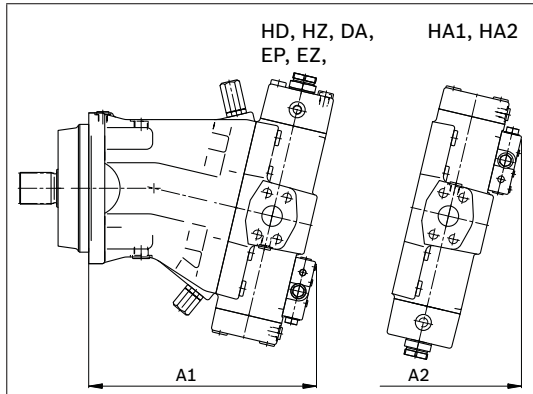

NG	A1	A2
250	357	402
355	397	446
500	440	504
1000	552	629

Counterbalance valve BVD and BVE

Before finalizing your design, request a binding installation drawing. Dimensions in mm.

Winch counterbalance valve BVD...W and BVE

Application options

- Winch drive in cranes (BVD and BVE)
- Track drive in excavator crawlers (BVD)

Example schematic for winch drive in cranes

A6VM80HD1D/63W-VAB38800B + BVE25W38S/51ND-V100K00D4599T30S00-0

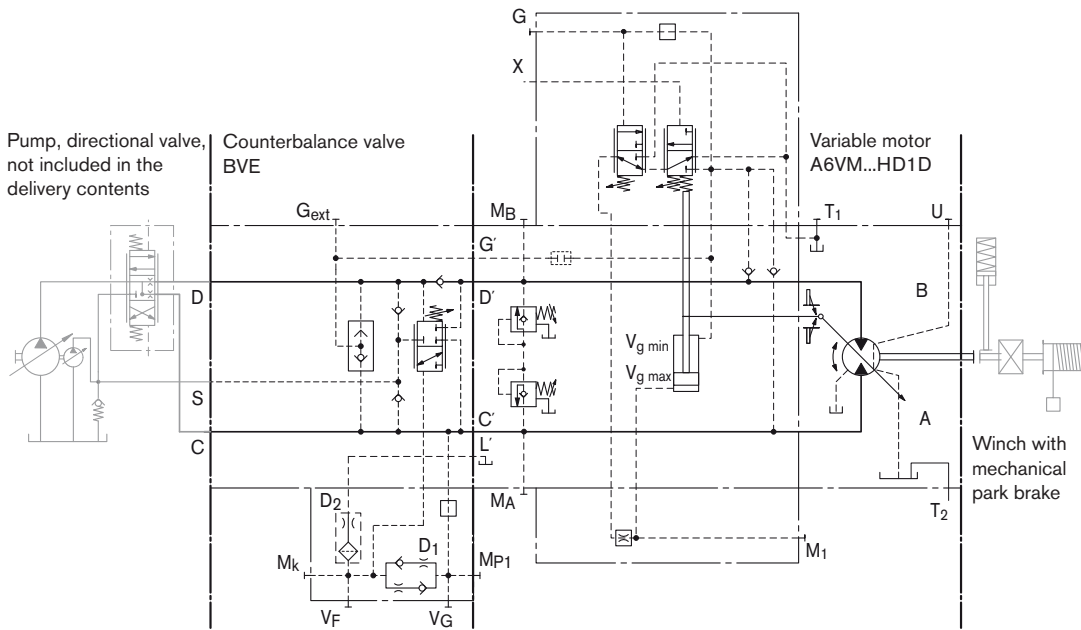

Permissible input flow or pressure in operation with DBV and BVD/BVE

Motor NG	Without valve		Restricted values in operation with DBV and BVD/BVE										
	p_{nom}/p_{max} [bar]	$q_v \max$ [L/min]	DBV			Code	BVD/BVE						
			NG	p_{nom}/p_{max} [bar]	q_v [L/min]		NG	p_{nom}/p_{max} [bar]	q_v [L/min]	Code			
55	400/450	244	22	350/420	240	380	20 (BVD)	350/420	220	388			
80		312	32		400						370		
107		380				25 (BVD/BVE)						320	388
107		380											
140		455											
160		496											
200	580	On request											
250	350/400	675	On request										

DBV _____ pressure-relief valve

BVD _____ counterbalance valve, double-acting

BVE _____ counterbalance valve, one-sided

Counterbalance valve BVD and BVE

Before finalizing your design, request a binding installation drawing. Dimensions in mm.

Dimensions

A6VM...HA

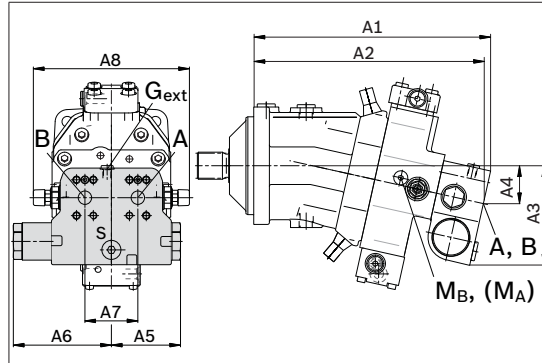

A6VM...HD or EP¹⁾

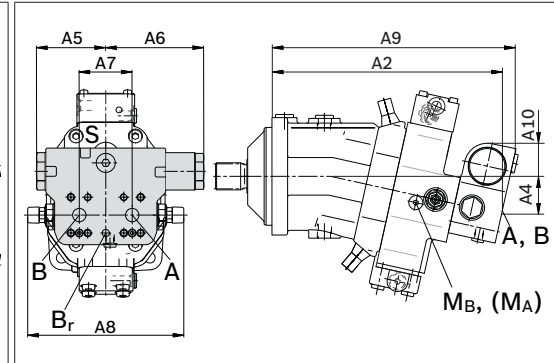

A6VM NG...plate	Counterbalance valve		Dimensions									
	Type	Ports A, B	A1	A2	A3	A4	A5	A6	A7	A8	A9	A10
55...38	BVD20...17	3/4 in	311	302	143	50	98	139	75	222	326	50
80...38	BVD20...27	1 in	340	331	148	55	98	139	75	222	355	46
107...37	BVD20...28	1 in	362	353	152	59	98	139	84	234	377	41
107...38	BVD25...38	1 1/4 in	380	370	165	63	120.5	175	84	238	395	56
140...38	BVD25...38	1 1/4 in	411	401	168	67	120.5	175	84	238	426	53
160...38	BVD25...38	1 1/4 in	417	407	170	68	120.5	175	84	238	432	51
200...38	BVD25...38	1 1/4 in	448	438	176	74	120.5	175	84	299	463	46
107...38	BVE25...38	1 1/4 in	380	370	171	63	137	214	84	238	397	63
140...38	BVE25...38	1 1/4 in	411	401	175	67	137	214	84	238	423	59
160...38	BVE25...38	1 1/4 in	417	407	176	68	137	214	84	238	432	59
200...38	BVE25...38	1 1/4 in	448	438	182	74	137	214	84	299	463	52

Ports

Designation	Port for	Version	A6VM Plate	Standard	Size ²⁾	Maximum pressure [bar] ³⁾	State ⁵⁾
A, B	Service line			SAE J518	see table above	420	O
S	Infeed	BVD20		DIN 3852 ⁴⁾	M22 x 1.5; 14 deep	30	X
		BVD25, BVE25		DIN 3852 ⁴⁾	M27 x 2; 16 deep	30	X
Br	Brake release, reduced high-pressure	L	7	DIN 3852 ⁴⁾	M12 x 1.5; 12.5 deep	30	O
			8	DIN 3852 ⁴⁾	M12 x 1.5; 12 deep	30	O
G _{ext}	Brake release, high-pressure	S		DIN 3852 ⁴⁾	M12 x 1.5; 12.5 deep	420	X
M _A , M _B	Measuring pressure A and B			ISO 6149 ⁴⁾	M18 x 1.5; 14.5 deep	420	X

1) At the mounting version for the controls HD and EP, the cast-in port designations A and B on the counterbalance valve BVD do not correspond with the connection drawing of the A6VM motor.

The designation of the ports on the installation drawing of the motor is binding!

2) Observe the general instructions on page 80 for the maximum tightening torques.

3) Momentary pressure spikes may occur depending on the application. Keep this in mind when selecting measuring devices and fittings.

4) The spot face can be deeper than specified in the appropriate standard.

5) O = Must be connected (plugged on delivery)

X = Plugged (in normal operation)

Counterbalance valve BVD and BVE

Before finalizing your design, request a binding installation drawing. Dimensions in mm.

Mounting the counterbalance valve

When delivered, the counterbalance valve is mounted to the motor with two tacking screws (transport protection). The tacking screws may not be removed while mounting the service lines. If the counterbalance valve and motor are delivered separately, the counterbalance valve must first be mounted to the motor port plate using the provided tacking screws. The counterbalance valve is finally mounted to the motor by screwing on the SAE flange with the following screws:

6 screws (1, 2, 3, 4, 5, 8) _____ length B1+B2+B3
2 screws (6, 7) _____ length B3+B4

Tighten the screws in two steps in the specified sequence from 1 to 8 (see following scheme).

In the first step, the screws must be tightened with half the tightening torque, and in the second step with the maximum tightening torque (see following table).

Thread	Strength class	Tightening torque [Nm]
M6 x 1 (tacking screw)	10.9	15.5
M10	10.9	75
M12	10.9	130
M14	10.9	205

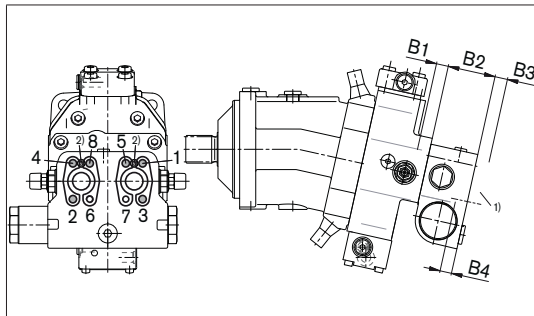

- 1) SAE flange
- 2) Tacking screw (M6 x 1, length = B1 + B2, DIN 912)

NG...plate	55...38	80...38, 107...37	107, 140, 160, 200...38
B1 ³⁾	M10 x 1.5 17 deep	M12 x 1.75 15 deep	M14 x 2 19 deep
B2	68	68	85
B3	customer-specific		
B4	M10 x 1.5 15 deep	M12 x 1.75 16 deep	M14 x 2 19 deep

- 3) Minimum required thread reach 1 x Ø-thread

Swivel angle indicator (sizes 250 to 1000)

Before finalizing your design, request a binding installation drawing. Dimensions in mm.

Optical swivel angle indicator (V)

The swivel position is indicated by a pin on the side of the port plate. The length of pin protruding depends on the position of the lens plate.

If the pin is flush with the port plate, the motor is at the beginning of control. At max. swivel, the pin length is 8 mm (visible after removing the cap nut).

Example: beginning of control at $V_{g \max}$

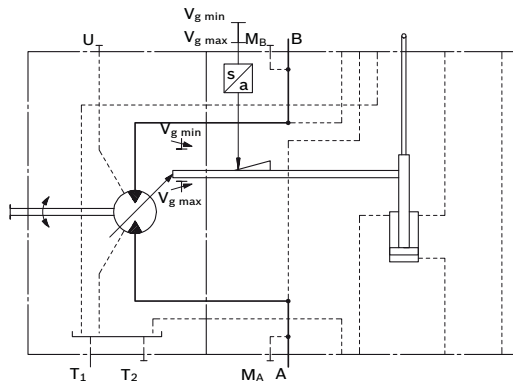

Electric swivel angle indicator (E)

The motor position is measured by an inductive position transducer. This converts the stroke of the control device into an electric signal.

This signal is used to forward the swivel position to an electric controller.

Inductive position transducer, type IW9-03-01
type of protection according to DIN/EN 60529: IP65

Example: beginning of control at $V_{g \min}$

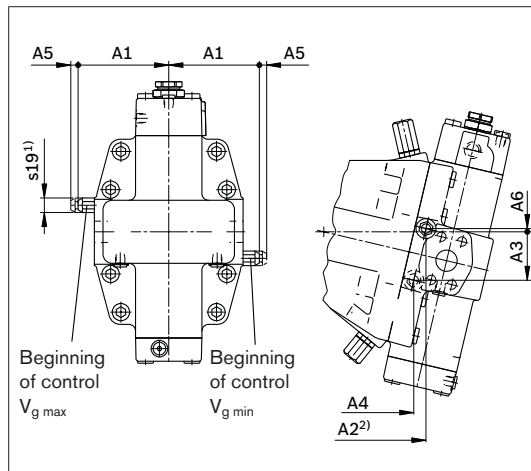
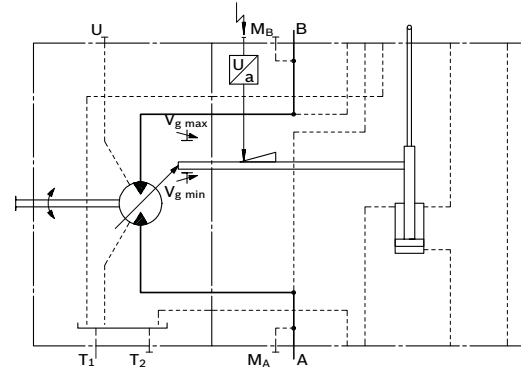

NG	A1	A2 ²⁾	A3	A4	A5 ³⁾	A6
250	136.5	256	73	238	11	5
355	159.5	288	84	266	11	8
500	172.5	331	89	309	11	3
1000	208.5	430	114	402	11	3

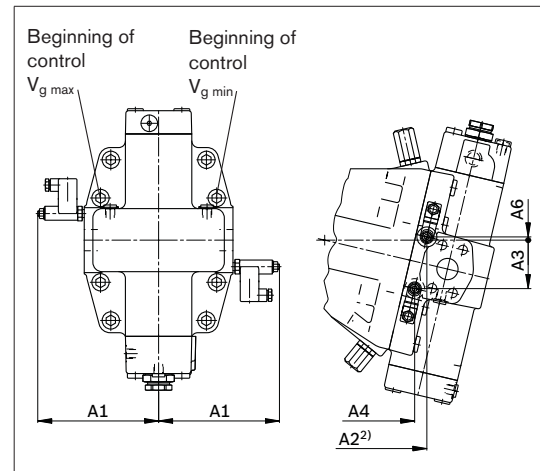

NG	A1	A2 ²⁾	A3	A4	A6
250	182	256	73	238	5
355	205	288	84	266	8
500	218	331	89	309	3
1000	254	430	114	402	3

- 1) Size
- 2) Dimension to mounting flange
- 3) Required clearance for removal of cap nut

Speed sensors

Version A6VM...U and A6VM...F ("prepared for speed sensor", i.e. without sensor) is equipped with a toothed ring on the rotary group.

On deliveries "prepared for speed sensor", the port is plugged with a pressure-resistant cover.

With the speed sensor DSA or HDD mounted, a signal proportional to the motor speed can be generated. The sensors measure the speed and direction of rotation.

Ordering code, technical data, dimensions and details on the connector, plus safety information about the sensor can be found in the relevant data sheet.

DSA _____ RE 95133

HDD _____ RE 95135

Version "V" (sizes 28 to 200)

Suitable for mounting the DSA speed sensor. The sensor is fastened at the upper reservoir port T₁.

Note

With speed measuring, only port T₂ can be used to drain the case drain.

Version "H" (sizes 355 and 500)

Suitable for mounting the HDD speed sensor. The sensor is flanged onto the port provided for this purpose with two mounting bolts.

We recommend ordering the A6VM variable motor complete with installed sensor.

Schematic

Sizes 28 to 200

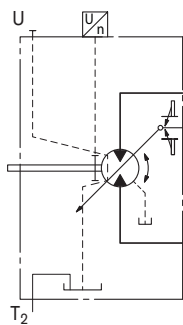

Sizes 250 to 1000

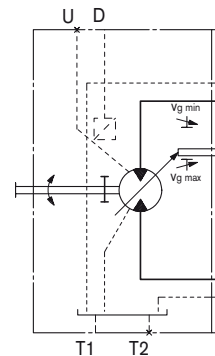

Before finalizing your design, request a binding installation drawing. Dimensions in mm.

Dimensions

Version "V" with DSA sensor (sizes 28 to 200)

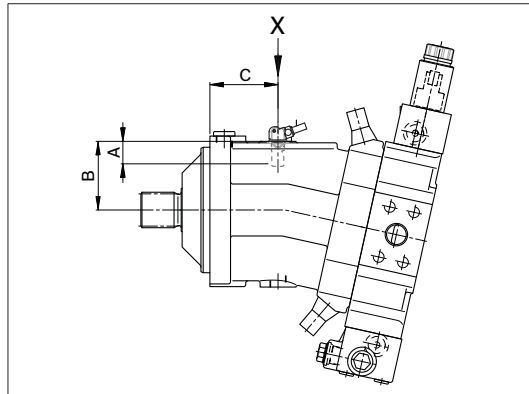

Dimensions

Version "H" with HDD sensor (sizes 355 and 500)

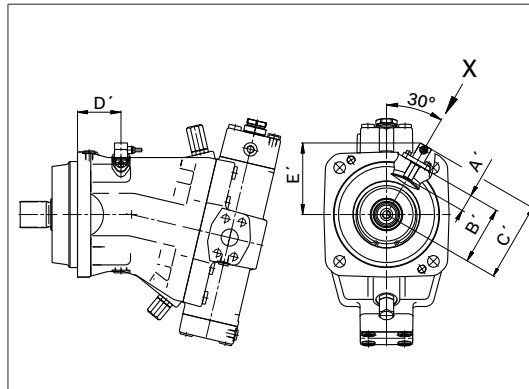

View X

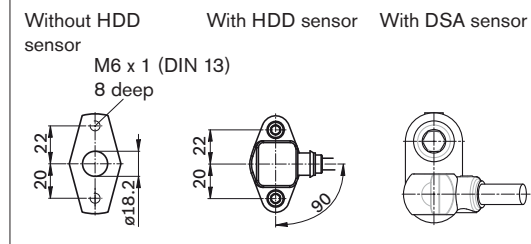

Size		55	80	107	140	160	200	250	355	500
Number of teeth		54	58	67	72	75	80	78	90	99
DSA	A Insertion depth (tolerance -0.25)	18.4	18.4	18.4	18.4	18.4	18.4	On request	-	-
	B Contact surface	75	79	88	93	96	101		-	-
	C	66.2	75.2	77.2	91.2	91.7	95.2		-	-
HDD	A' Insertion depth (tolerance ± 0.1)	-	-	-	-	-	-	-	32.5	32.5
	B' Contact surface	-	-	-	-	-	-	-	122.5	132.5
	C'	-	-	-	-	-	-	-	161	171
	D'	-	-	-	-	-	-	-	93	113
	E'	-	-	-	-	-	-	-	145	154

Installation instructions

General

During commissioning and operation, the axial piston unit must be filled with hydraulic fluid and air bled. This must also be observed following a relatively long standstill as the axial piston unit may drain back to the reservoir via the hydraulic lines.

Particularly in the installation position "drive shaft upwards" filling and air bleeding must be carried out completely as there is, for example, a danger of dry running.

The case drain fluid in the motor housing must be directed to the reservoir via the highest available drain port (T_1 , T_2).

For combinations of multiple units, make sure that the respective case pressure in each unit is not exceeded. In the event of pressure differences at the drain ports of the units, the shared drain line must be changed so that the minimum permissible case pressure of all connected units is not exceeded in any situation. If this is not possible, separate drain lines must be laid if necessary.

To achieve favorable noise values, decouple all connecting lines using elastic elements and avoid above-reservoir installation.

In all operating conditions, the drain line must flow into the reservoir below the minimum fluid level.

Installation position

See the following examples 1 to 8.

Further installation positions are possible upon request.

Recommended installation positions: 1 and 2.

Note

In certain installation conditions, an influence on the control characteristics can be expected. Gravity, dead weight and case pressure can cause minor shifts in control characteristics and changes in response time.

Installation position	Air bleed	Filling
1	-	T_1
2	-	T_2
3	-	T_1
4	U	T_1
5	U (L_1)	T_1 (L_1)
6	L_1	T_2 (L_1)
7	L_1	T_1 (L_1)
8	U	T_1 (L_1)

L_1 Filling / air bleed

U Bearing flushing / air bleed port

T_1 , T_2 Drain port

$h_{t \min}$ Minimum required immersion depth (200 mm)

h_{\min} Minimum required spacing to reservoir bottom (100 mm)

Below-reservoir installation (standard)

Below-reservoir installation means that the axial piston unit is installed outside of the reservoir below the minimum fluid level.

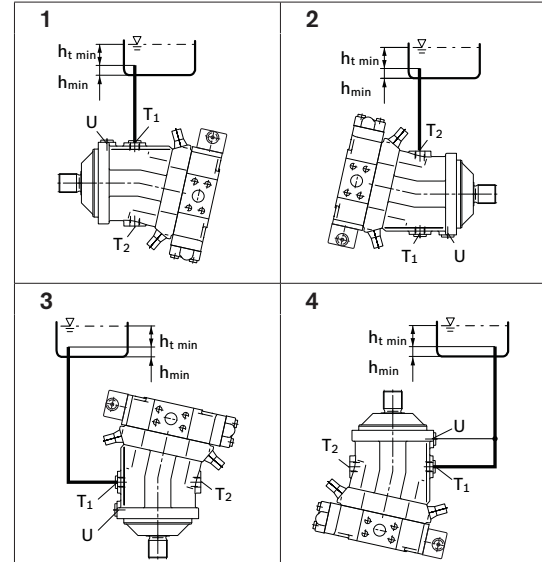

Above-reservoir installation

Above-reservoir installation means that the axial piston unit is installed above the minimum fluid level of the reservoir.

Recommendation for installation position 8 (drive shaft upward): A check valve in the drain line (cracking pressure 0.5 bar) can prevent draining of the motor housing.

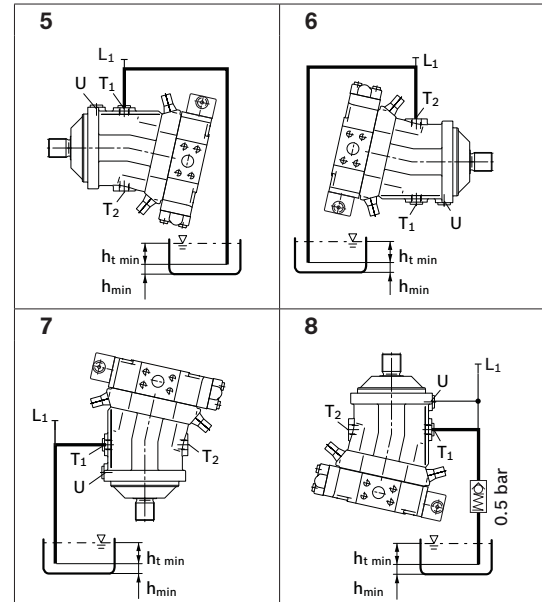

General instructions

- The motor A6VM is designed to be used in open and closed circuits.
- The project planning, installation and commissioning of the axial piston unit requires the involvement of qualified personnel.
- Before using the axial piston unit, please read the corresponding instruction manual completely and thoroughly. If necessary, these can be requested from Bosch Rexroth.
- During and shortly after operation, there is a risk of burns on the axial piston unit and especially on the solenoids. Take appropriate safety measures (e. g. by wearing protective clothing).
- Depending on the operating conditions of the axial piston unit (operating pressure, fluid temperature), the characteristic may shift.
- Service line ports:
 - The ports and fastening threads are designed for the specified maximum pressure. The machine or system manufacturer must ensure that the connecting elements and lines correspond to the specified application conditions (pressure, flow, hydraulic fluid, temperature) with the necessary safety factors.
 - The service line ports and function ports can only be used to accommodate hydraulic lines.
- The data and notes contained herein must be adhered to.
- The product is not approved as a component for the safety concept of a general machine according to ISO 13849.
- The following tightening torques apply:
 - Fittings:
 - Observe the manufacturer's instruction regarding tightening torques for the fittings used.
 - Mounting bolts:
 - For mounting bolts with metric ISO thread according to DIN 13 or thread according to ASME B1.1, we recommend checking the tightening torque in individual cases in accordance with VDI 2230.
 - Female threads in the axial piston unit:
 - The maximum permissible tightening torques $M_{G \max}$ are maximum values for the female threads and must not be exceeded. For values, see the following table.
 - Threaded plugs:
 - For the metallic threaded plugs supplied with the axial piston unit, the required tightening torques of threaded plugs M_V apply. For values, see the following table.

Ports Standard	Size of thread	Maximum permissible tightening torque of the female threads $M_{G \max}$	Required tightening torque of the threaded plugs $M_V^{1)}$	WAF hexagon socket of the threaded plugs
DIN 3852	M12 x 1.5	50 Nm	25 Nm ²⁾	6 mm
	M14 x 1.5	80 Nm	35 Nm	6 mm
	M16 x 1.5	100 Nm	50 Nm	8 mm
	M18 x 1.5	140 Nm	60 Nm	8 mm
	M22 x 1.5	210 Nm	80 Nm	10 mm
	M26 x 1.5	230 Nm	120 Nm	12 mm
	M27 x 2	330 Nm	135 Nm	12 mm
	M33 x 2	540 Nm	225 Nm	17 mm
	M42 x 2	720 Nm	360 Nm	22 mm

- 1) The tightening torques apply for screws in the "dry" state as received on delivery and in the "lightly oiled" state for installation.
- 2) In the "lightly oiled" state, the M_V is reduced to 17 Nm for M12 x 1.5.

© This document, as well as the data, specifications and other information set forth in it, are the exclusive property of Bosch Rexroth AG. It may not be reproduced or given to third parties without its consent.

The data specified above only serve to describe the product. No statements concerning a certain condition or suitability for a certain application can be derived from our information. The information given does not release the user from the obligation of own judgment and verification. It must be remembered that our products are subject to a natural process of wear and aging.

Subject to change.