



ROEMHELD
HILMA ■ STARK

Issue 5-10 E

B 1.9501

Threaded-Body Work Supports with metallic wiper edge, 3 sizes, 3 types of function, single acting, max. operating pressure 500 bar

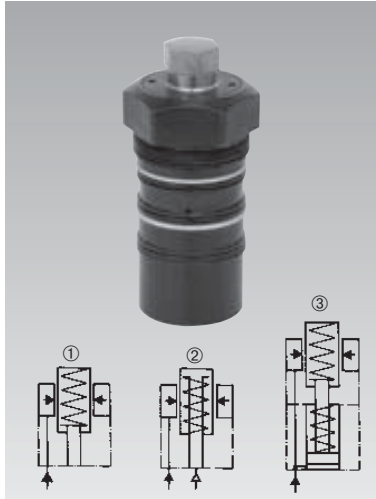

Advantages

- Space-saving threaded-body version
- 3 sizes
- 3 types of function
- Contact force by spring or pneumatically adjustable (195X-021)
- Load force up to 100 kN
- Venting for spring area universally connectable
- Metallic wiper edge and FKM wiper
- Connection of positive air pressure protection is possible
- Support plunger and interior parts protected against corrosion

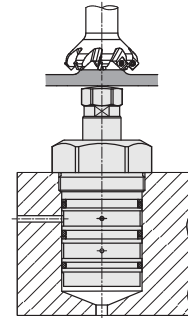

Types of function

1. Spring advanced

Page 2

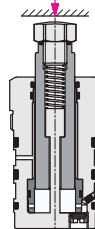

2. Air pressure advanced

Page 3

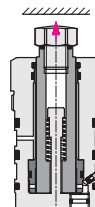

3. Hydraulic pressure and spring advanced

Page 4

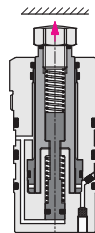

Combination with clamping elements

Page 5

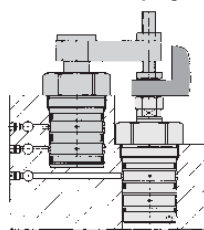

Admissible load force as a function of the operating pressure

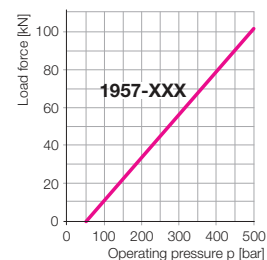
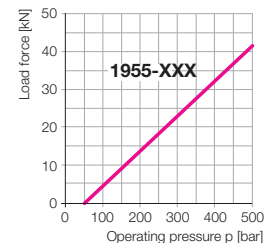
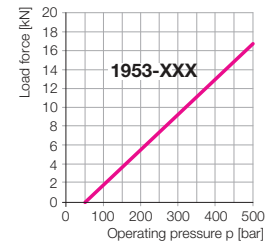

Application

Hydraulic work supports are used to provide a self-adjusting rest for the workpiece during the machining operations. They compensate the workpiece surface irregularities, also vibration and deflection under machining loads.

The threaded-body design allows for space-saving and direct installation into the fixture body. Oil supply is made through drilled channels.

Description

In the body of the threaded-body work support a thin-walled locking bush is integrated, which locks cylindrically around the freely-movable support plunger when pressurising the element with hydraulic oil.

The elements are protected against penetration of swarf by a metallic wiper edge and sealed against liquids. The venting port allows also the connection of positive air pressure protection.

Important notes!

Work supports are not suitable to compensate side loads.

If there is any danger of fluids being sucked into the filter, a vent hose has to be connected at the element or a venting port in the fixture body! Fluids must not be sucked in at the end of the vent connection!

The 3 connecting possibilities are presented on the pages 2, 3 and 4.

It is absolutely necessary to follow the instructions for venting of the spring area see data sheet A 0.110. The positive air pressure protection pressure > 0.2 bar must only be activated after hydraulic locking.

Operating conditions, tolerances and other data see data sheet A 0.100.

Important note!

Machining forces can generate vibrations, whose amplitude exceeds an average value, and this can cause yielding of the support plunger.

Remedy: increase the safety factor or the number of work supports.

Type of function: Spring advanced
off-position extended, contact by spring force

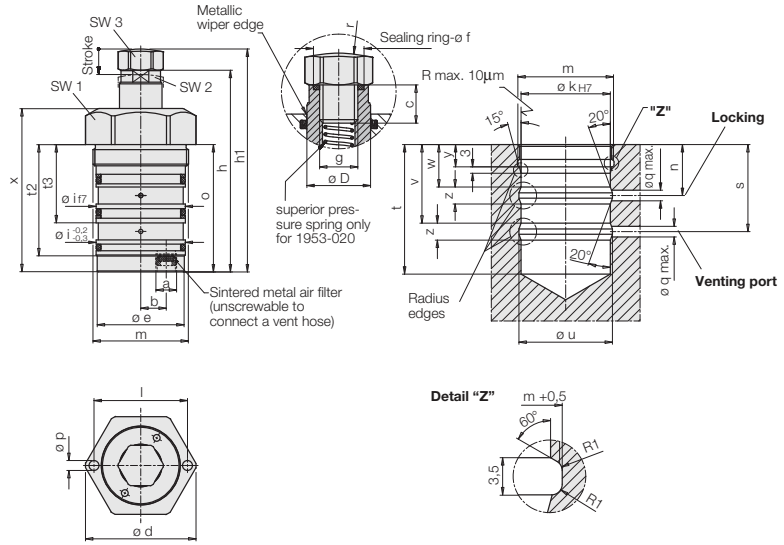
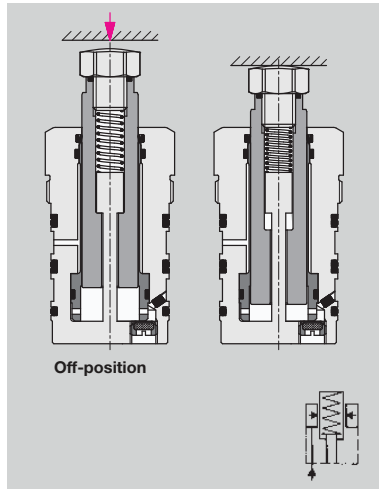

The support plunger is pushed back by the inserted workpiece, the spring force has to be overcome.

The support plunger will be locked by hydraulic pressure and can compensate forces in axis direction.

After unclamping the support plunger contacts still the workpiece with spring force, until the workpiece will be unloaded from the fixture.

1. Venting via pocket hole

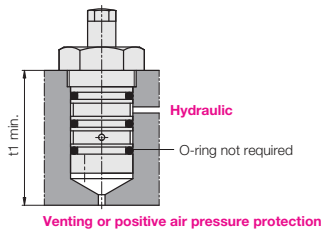

2. Venting via drilled channels

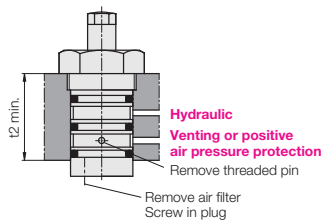

3. Venting via hoses

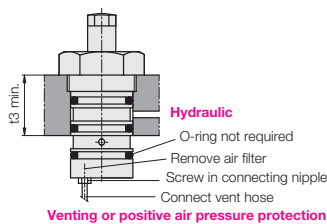

Support plunger Ø D	[mm]	20	32	50
Stroke	[mm]	12	16	20
Load force at 200/500 bar	[kN]	5.6/16.8	14/42	34/102
Plunger contact force min./max.	[N]	15/25	30/60	50/100
Elastic deformation at 500 bar*	[mm/kN]	0,004	0,003	0,002
a	[mm]	G 1/8	G 1/8	G 1/4
b	[mm]	12	18	30,5
c	[mm]	12	12	20
Ø d	[mm]	52	64	100
Ø e	[mm]	41	53	83
Ø f	[mm]	15.9	15.9	19.6
g	[mm]	M 12	M 12	M 16
h	[mm]	95	119	174
h1	[mm]	105	129	184
Ø i f7	[mm]	42	55	85
Ø k H7	[mm]	42	55	85
l	[mm]	-	-	86
m	[mm]	M 45 x 1.5	M 60 x 1.5	M 90 x 2
n	[mm]	24	29	41
o	[mm]	60	66	126
Ø p / deep	[mm]	-	-	8/9
Ø q max.	[mm]	5	5	6
r	[mm]	45	45	60
s	[mm]	41	46.5	64
t	[mm]	61	67	127
t1	[mm]	75	85	155
t2	[mm]	52	58	80
t3	[mm]	36	43	60
Ø u	[mm]	44	57	87
v	[mm]	37	41.5	59
w	[mm]	20	24	36
x	[mm]	77	99	146
y	[mm]	10.5	12.5	20.5
z	[mm]	8	10	10
SW 1	[mm]	46	55	95
SW 2	[mm]	17	27	41
SW 3	[mm]	19	19	24

Part no.	1953-020	1955-020	1957-020
Spare seals - Seal kit for external seals	0132-384	0132-385	0132-386
Spare sealing ring for contact bolt	3001-731	3001-731	3002-018

Accessory for venting

Type of venting 1**	Air filter	3302-008	3302-008	3302-009
Type of venting 1**	Threaded pin M 3 x 4	3301-461	3301-461	3301-461
Type of venting 2	Plug	0361-986	0361-986	0361-987
Type of venting 3	Connecting nipple	3890-092	3890-092	3890-093
Type of venting 3	Plastic hose	3890-131	3890-131	3890-131

* during load

** Included in the delivery

**Type of function: Air pressure advanced
extend and contact by air pressure**

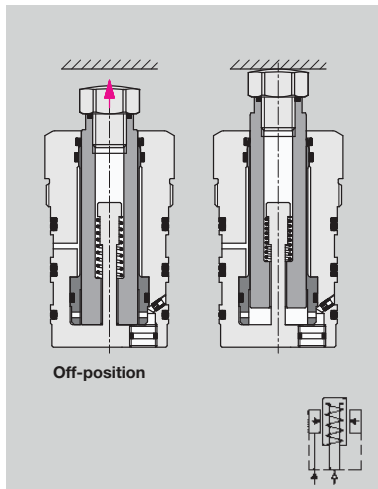

The support plunger contacts the workpiece by air pressure. The contact force is proportional to the air pressure less spring return force.

The support plunger will be locked by hydraulic pressure and can compensate forces in axis direction.

For unclamping hydraulic and air pressure will be released and the support plunger retracts by spring force to its off-position.

1. Pneumatic via pocket hole

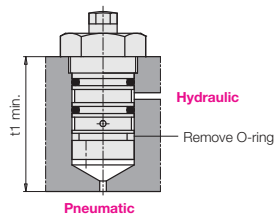

2. Pneumatic via drilled channels

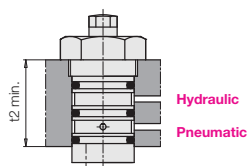

3. Pneumatic via hoses

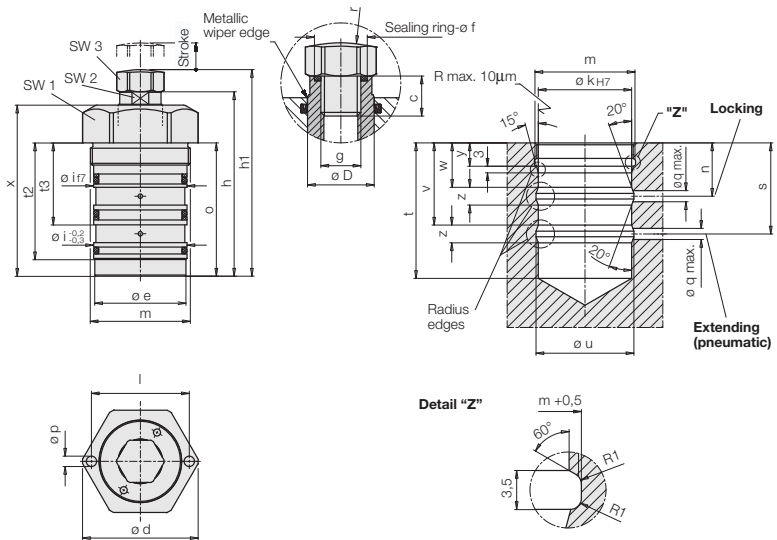
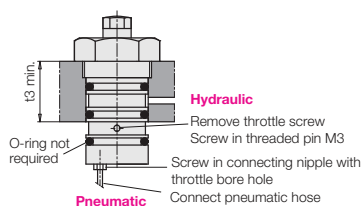

Support plunger Ø D	[mm]	20	32	50
Stroke	[mm]	12	16	20
Load force at 200 bar	[kN]	5.6/16.8	14/42	34/102
Spring force min./max.	[N]	15/25	30/60	50/100
Plunger contact force at 1 bar air pressure (deduct spring force if necessary)	[N]	31	80	196
Elastic deformation at 500 bar*	[mm/kN]	0.004	0.003	0.002
a	[mm]	G 1/8	G 1/8	G 1/4
b	[mm]	12	18	30.5
c	[mm]	12	12	20
Ø d	[mm]	52	64	100
Ø e	[mm]	41	53	83
Ø f	[mm]	15.9	15.9	19.6
g	[mm]	M 12	M 12	M 16
h	[mm]	83	103	154
h1	[mm]	93	113	164
Ø i f7	[mm]	42	55	85
Ø k H7	[mm]	42	55	85
l	[mm]	-	-	86
m	[mm]	M 45 x 1.5	M 60 x 1.5	M 90 x 2
n	[mm]	24	29	41
o	[mm]	60	66	126
Ø p / deep	[mm]	-	-	8/9
Ø q max.	[mm]	5	5	6
r	[mm]	45	45	60
s	[mm]	41	46.5	64
t	[mm]	61	67	127
t1	[mm]	75	85	155
t2	[mm]	52	58	80
t3	[mm]	36	43	60
Ø u	[mm]	44	57	87
v	[mm]	37	41.5	59
w	[mm]	20	24	36
x	[mm]	77	99	146
y	[mm]	10.5	12.5	20.5
z	[mm]	8	10	10
SW 1	[mm]	46	55	95
SW 2	[mm]	17	27	41
SW 3	[mm]	19	19	24

Part no.	1953-021	1955-021	1957-021
Spare seals – Seal kit for external seals	0132-384	0132-385	0132-386
Spare sealing ring for contact bolt	3001-731	3001-731	3002-018

Accessory for venting			
Type of venting 1+2**	Plug	0361-986	0361-986
	Throttle screw	3610-151	3610-150
	Connecting nipple	3890-190	3890-191
Type of venting 3	Threaded pin M 3 x 4	3301-461	3301-461
	Plastic hose	3890-131	3890-131

* during load

** Included in the delivery

Combination with clamping elements

Dimensioning of the load force of work supports

The admissible load force of work supports has always to be dimensioned so that the clamping force of the used clamping elements and the static and dynamic machining forces can be safely compensated.

- Admissible load force**
- Clamping force
 - Safety (reserve)
-
- = Possible machining force

If the total of all occurring forces exceeds the admissible load force, the support plunger of the work support will be pushed back and the work support will be damaged.

Ratio of load force to clamping force

On principle the load force of the work supports should be at least twice the clamping force of the clamping elements.

Load force $\geq 2 \times$ clamping force

Clamping onto the work support

Control of clamping sequence

The sequence – supporting and clamping – has to be controlled as a function of the pressure, e.g. by a sequence valve.

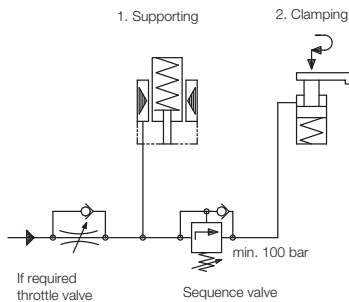

The sequence valve has to be adjusted to an opening pressure above the intersection of the two straight lines in the diagram.

If due to a too high flow rate a throttle valve is required, installation should be made as shown in the hydraulic circuit diagram.

Combinations work supports with swing clamps of the same size

To get a load force twice the clamping force, for all 3 sizes of work supports an operating pressure of at least 200 bar is required.

The vertical distance of the two straight lines in the area of the colorised surface indicates the resulting maximally possible machining force including reserve.

Example

The threaded-body swing clamp 1895-101 (data sheet B 1.892) clamps a workpiece onto the work support 1955-022.

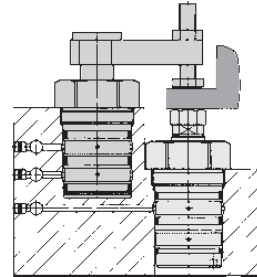

Size 1953

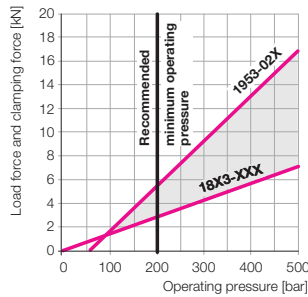

For size 1955 the following can be taken from the diagram:

Minimum operating pressure: 200 bar
Load force at 200 bar: 14 kN
Clamping force at 200 bar: 7 kN

Possible machining force at 200 bar:

Admissible load force: 14 kN
- Clamping force: - 7 kN
= Possible machining force: 7 kN
(including reserve)

Size 1955

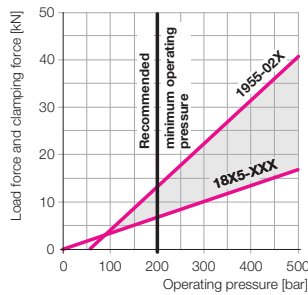

Size 1957

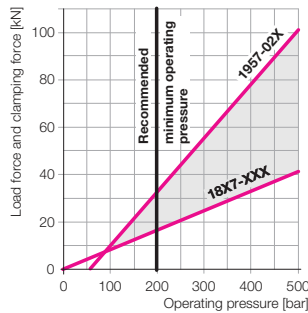

Important note!

The admissible load forces as per the diagram are static. The machining forces can also generate vibrations which exceed by far the mean value. For this reason a corresponding safety factor has to be taken into account.