

Grip rail coupling

Rapid action clamping system for transfer presses



HILMA

Active part of the coupling

The active part of the grip rail coupling is of a mechanical, hydraulic or electro-mechanical design, depending on the required degree of automation.

Passive part of the coupling

The passive part is identical for all the above types.

Application:

- Automatic centering, coupling and clamping of grip rails on transfer presses
- The coupling is used whenever the maximum clamping force with high dynamic strength in the smallest space is required.



hydraulic



mechanical



electromechanical

Function:

In contrast to conventional systems, the new coupling design is such that all components for positioning, centering, clamping force build-up and position control are integrated into the active part of the coupling which is firmly connected to the press. The passive part does not have any moving parts.

In order to keep the weight of the coupling low, the housings of both the active and the passive parts are made from hard-coated, high-strength aluminium.

When moving the two halves of the coupling into position (insertion of grip rail), these are precentered using guide elements. Positioning pins on the active part locate into drilled holes in the passive part, thereby centering the coupling and ensuring a high degree of reproducibility. The clamping force is built up using a tie rod and maintained in a self-locking manner.

A compact self-control system installed in the element is easily adaptable to a bus system and this ensures exact positioning and clamping.

As an option, rapid action couplings for electrical power, compressed air and hydraulic fluid as per customer's specification can be fitted.

Special features:

- ◆ Safe coupling and uncoupling in a matter of a few seconds.
- ◆ Die positions are reproducible in a very short time
- ◆ High positioning accuracy of ± 0.02 mm
- ◆ Easy retrofit
- ◆ No moving parts in the passive part of the coupling, thus making the coupling maintenance-free and affordable
- ◆ Self-locking
- ◆ High dynamic strength
- ◆ Flexible design of the couplings for electrical power, compressed air and hydraulic fluid as per customer's specification

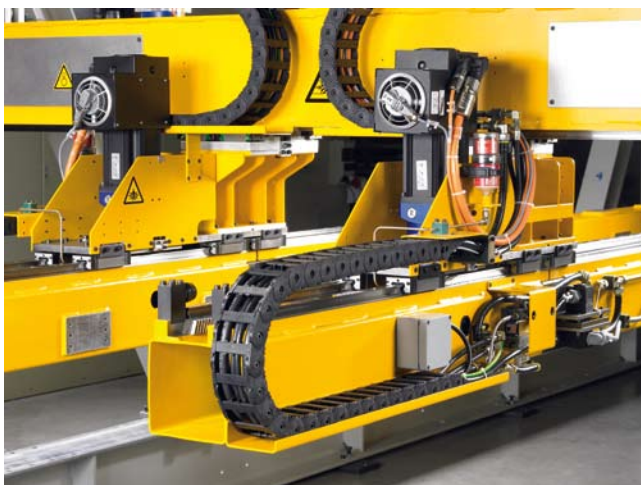

Example of an application: 3-axis transfer system with hydraulic grip rail coupling (transfer rail coupling)



GSH version:

Grip rail coupling, hydraulic

Size	GSH 60	GSH 100
Clamping force (kN)	60	100
Operating pressure (bar)	60	60
A (mm)	115	200
A1 (mm)	160	200
B (mm)	100	120
C (mm)	80	100
D (mm)	95	84
E (mm)	—	175
Weight (kg)	10,5	27
Centering reproducibility (mm)	± 0,02	± 0,02
Perm. horizontal positioning accuracy (mm)	-1/+3	-1/+3
Perm. axis offset (mm)	± 2	± 2

Further technical details on request or determined in the course of the project.

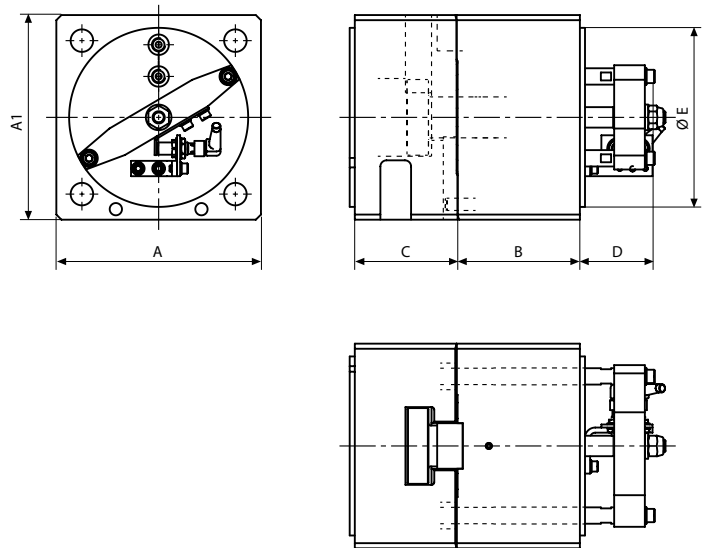

Fastening dimensions on request or according to customer's requirements

Function: hydraulic

After applying hydraulic pressure, the coupling halves are centered, clamping force is built up and the tie rod is mechanically locked.

Even in the event of a pressure drop the clamping force is fully maintained by mechanical self-locking.

For reasons of safety we recommend that the hydraulic pressure is maintained.

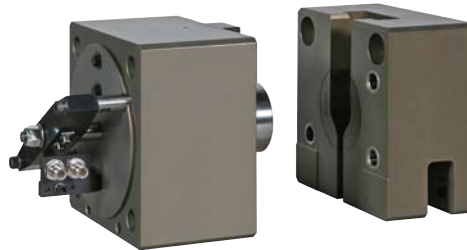

Possibilities of positioning and changing

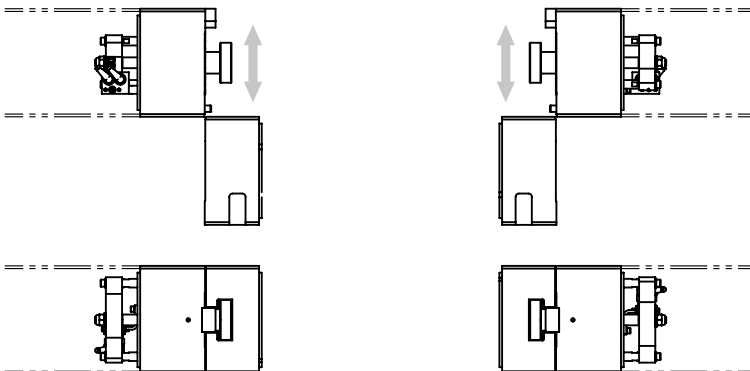

Grip rail coupling

Rapid action clamping system for transfer presses



HILMA

GSM version:

Grip rail coupling, mechanical

Size	GSM 60	GSM 100
Clamping force (kN)	60	100
M _s (Nm)	180	300
A (mm)	115	200
A1 (mm)	160	200
B (mm)	100	120
C (mm)	80	100
D (mm)	65	71
E (mm)	—	175
Weight (kg)	12,5	29
Centering reproducibility (mm)	± 0,02	± 0,02
Perm. horizontal positioning accuracy (mm)	-1/+3	-1/+3
Perm. axis offset (mm)	± 2	± 2

Further technical details on request or determined in the course of the project.

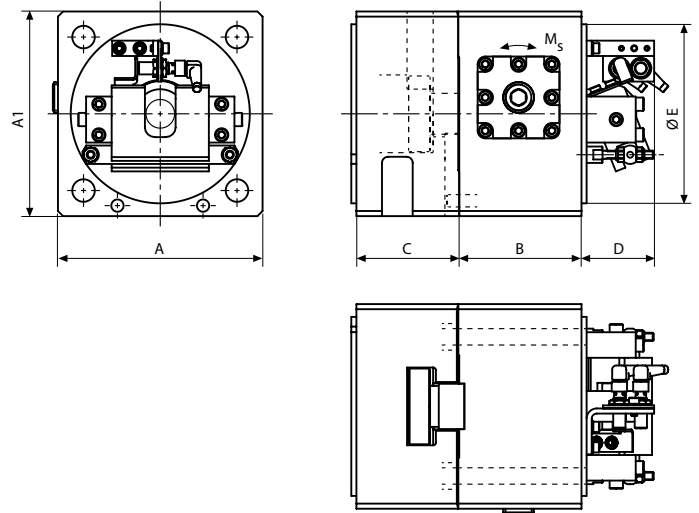

Fastening dimensions on request or according to customer's requirements

Function: mechanical

By turning the hexagon socket the positioning pins are extended using a wedge system for centering the coupling halves, and the clamping force is built up. The self-locking wedge system, the high clamping forces and the high dynamic strength are the outstanding features of this clamping element.

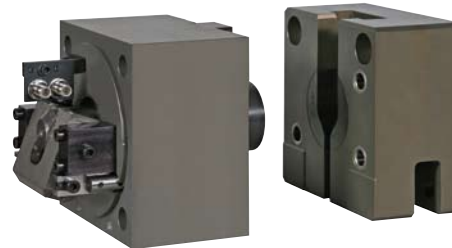

Possibilities of positioning and changing

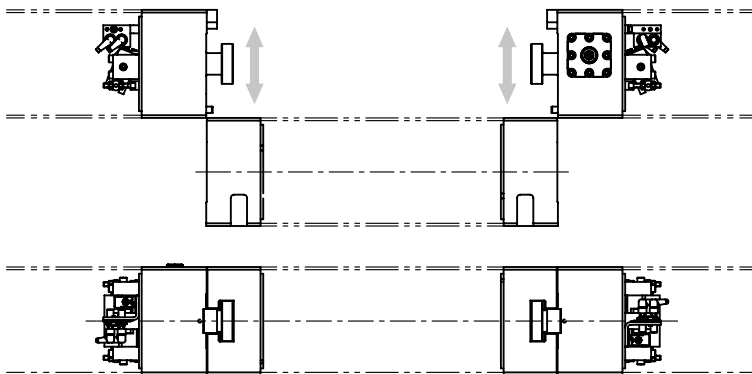



GSE version:

Grip rail coupling, electromechanical

	Size	GSE 100
Clamping force (kN)		100
Motor output (kW)		0,25
A (mm)		200
A1 (mm)		200
B (mm)		120
C (mm)		100
D (mm)		225
E (mm)		175
Weight (kg)		39
Centering reproducibility (mm)		± 0,02
Perm. horizontal positioning accuracy (mm)		-1/+3
Perm. axis offset (mm)		± 2

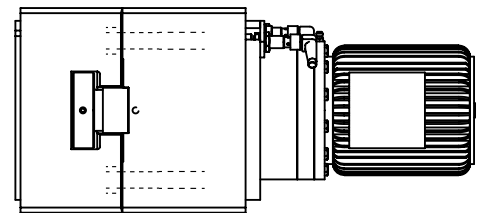
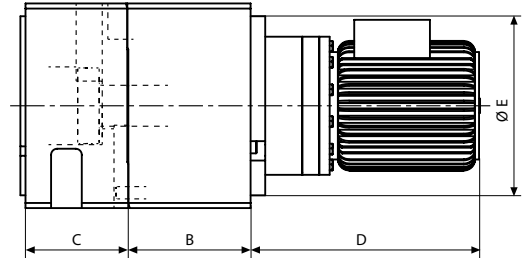
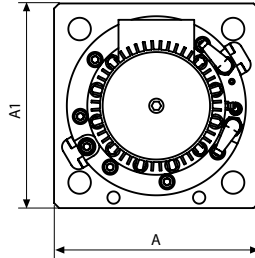

Further technical details on request or determined in the course of the project.

Fastening dimensions on request or according to customer's requirements

Function: electromechanical

The rotary movement of the drive motor is transmitted to the tie rod and the positioning pins using a flex-spline gear and a spindle drive. The operating principle and the arrangement of the gear, position control and automatic sequence of movement ensure high operational reliability.



Possibilities of positioning and changing

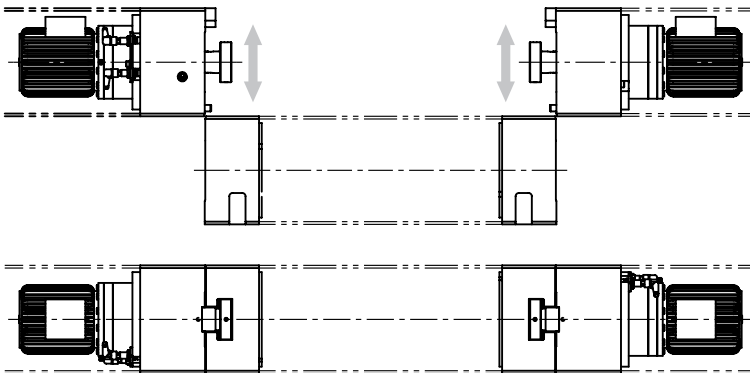

Grip rail coupling

Rapid action clamping system for transfer presses



HILMA

GSHM version: hydro-mechanical

- with visual clamping force control
- without precision centering and position control

Grip rail coupling, hydro-mechanical

Clamping force (kN)	Size	GSHM 45
M_s (Nm)		45
A (mm)		15
A1 (mm)		80
B (mm)		80
C (mm)		70
Masse (kg)		37
Centering reproducibility (mm)		2
Perm. horizontal positioning accuracy (mm)		$\pm 0,15$
Perm. axis offset (mm)		-1/+2

Further technical details on request or determined in the course of the project.

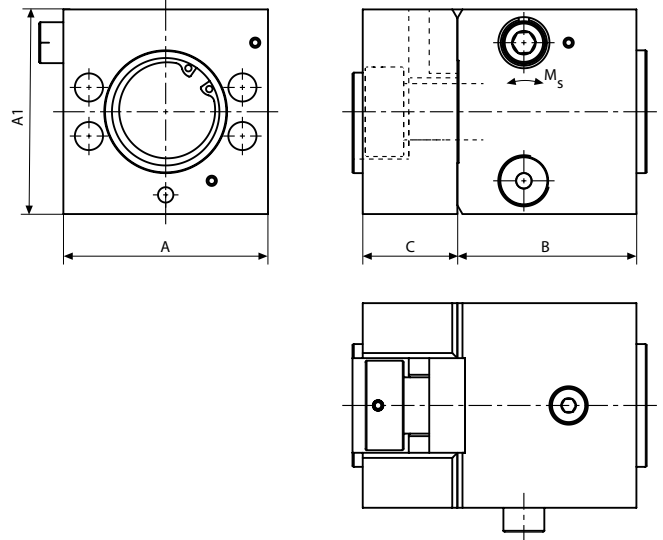

Fastening dimensions on request or according to customer's requirements

Function: hydro-mechanical

By turning the hexagon socket the integral hydraulic pad is preloaded and transforms a low torque into a high clamping force. An indicator pin indicates that the clamping force has been reached.

