

**Rexroth**  
Bosch Group

## External gear pump Series B

**RE 10 088/09.13**  
Replaces: RE 10 088/09.12

**AZPB-3x**

Fixed pumps  
 $V = 1.0 \dots 7.1 \text{ cm}^3/\text{rev}$

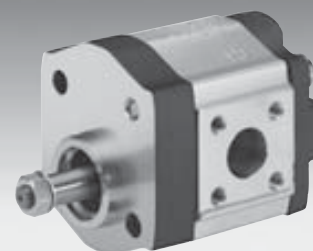

### Overview of contents

#### Contents

General	2
Product overview	3
Ordering code single pumps	4
Ordering code multiple pumps	5
Drive shaft	6
Front cover	6
Line ports	7
Gear pumps with integrated pressure-relief valve	7
Performance charts	8
Noise charts	11
Design calculations for pumps	12
Specifications	13
Drive Arrangements	14
Multiple gear pumps	15
Dimensions	16
Fittings	26
Notes on commissioning and maintenance	27
Spare parts	28
The AZ configurator	29
Ordering-No.	30

### Features

<b>Page</b>	– Nominal pressure 250 bar (up to $6.3 \text{ cm}^3/\text{rev}$ )
2	– Slide bearings for heavy duty applications
3	– Standardized drive shafts
4	– Line ports:
5	Connection flange or internal thread
6	– Long service life through reinforced design
6	of shafts and cast iron cover
7	– Consistent high quality through mass production
7	– Numerous configuration variants available
8	– Same mounting dimensions as the AZPB-1x
11	
12	
13	
14	
15	
16	
26	
27	
28	
29	
30	

## General

Rexroth external gear pumps are available as standard gear pumps in the 4 series of B, F, N and G and as SILENCE gear pumps in the S, T and U series, and as the SILENCE PLUS version in the J series, in which the displacements are graded by different gear widths. Further configuration variants are given by different flanges, shafts, valve arrangements and multiple pump combinations.

## Construction

The external gear pump consists essentially of a pair of gears supported in bearing bushings and the housing with a front and a rear cover. The drive shaft protrudes from the front cover where it is sealed by the shaft seal ring. The bearing forces are absorbed by special slide bearings with sufficient elasticity to produce surface contact instead of line contact. They also ensure excellent resistance to galling – especially at low speed. The gear wheels of the standard and SILENCE pumps have 12 teeth and the gear wheels of the SILENCE PLUS have 7 non-evolute teeth. This keeps both flow pulsation and noise emission to a minimum.

The internal sealing is achieved by forces which are proportional to delivery pressure. This ensures optimum efficiency. The bearings provide the seal at the ends of the gaps between the teeth which carry the pressurized oil. The sealing zone between the gear teeth and the bearings is controlled by the admission of operating pressure to the rear of the bearings. Special seals form the boundary of the zone. The radial clearance at the tips of the gear teeth is sealed by internal forces pushing them against the case.

### Axial and radial compensation for gear pump

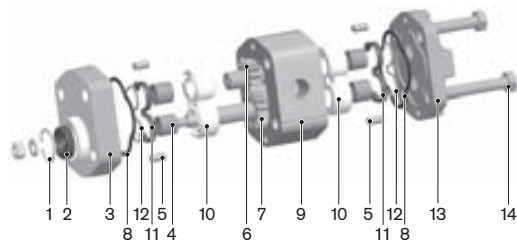
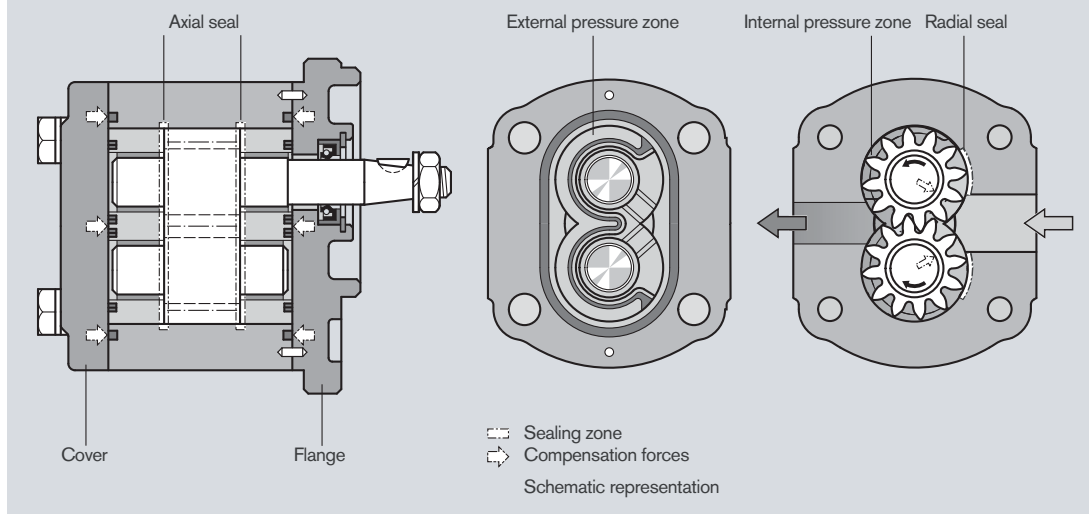

- |                   |                       |
|-------------------|-----------------------|
| 1 Retaining ring  | 8 Housing seal        |
| 2 Shaft seal ring | 9 Pump housing        |
| 3 Front cover     | 10 Bearing            |
| 4 Slide bearing   | 11 Axial zone seal    |
| 5 Centering pin   | 12 Supporting element |
| 6 Gear            | 13 End cover          |
| 7 Gear (driving)  | 14 Fixing screws      |

Overview of "Series B" standard program

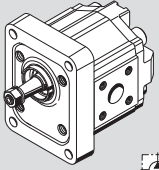
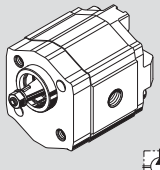
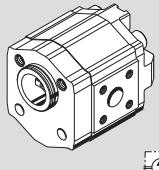
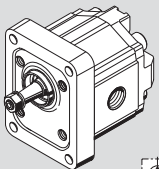
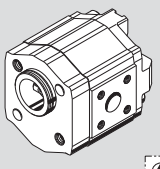
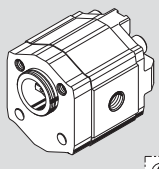
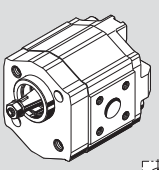
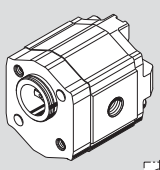
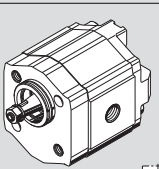
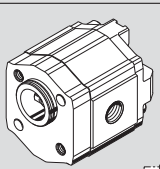









Version	Page	Version	Page	Version	Page
	16		20		24
	17		21		25
	18		22		
	19		23		

## Ordering code

### External gear units Single pumps Standard

<b>AZ</b>	<b>P</b>	<b>B</b>	<b>-</b>	<b>x</b>	<b>x</b>	<b>-</b>	<b>4.0</b>	<b>R</b>	<b>C</b>	<b>P</b>	<b>02</b>	<b>M</b>	<b>D</b>	<b>200 xx</b>	<b>S xxxx</b>		
<b>Function</b> P = Pump <b>Series</b> 3 = 3rd generation <b>Version</b> 2 = corrosion-resistant, pinned <b>Size (B)</b> 1.0 = 1.00 cm <sup>3</sup> /rev 2.0 = 2.00 cm <sup>3</sup> /rev 2.5 = 2.50 cm <sup>3</sup> /rev 3.1 = 3.15 cm <sup>3</sup> /rev 4.0 = 4.00 cm <sup>3</sup> /rev 4.5 = 4.50 cm <sup>3</sup> /rev 5.0 = 5.00 cm <sup>3</sup> /rev 6.3 = 6.30 cm <sup>3</sup> /rev 7.1 = 7.10 cm <sup>3</sup> /rev <b>Direction of rotation</b> R = Clockwise L = Counterclockwise																Special design *)  Valve adjustment 200 xx = PRV 200 bar	
										<b>Rear cover</b> B = Standard A = Axial inlet and outlet port							
										<b>Seals</b> M = NBR K = NBR, shaft seal ring in FKM P = FKM							



























\*) Some of the special designs shown on pages 16-25 are not covered in the illustration of the ordering code.

Drive shafts			Front cover			Line ports			
<b>C</b>	Tapered key shaft 1:5		<b>P</b>	<b>P</b>	2-bolt mounting Centering Ø 32 mm		<b>01</b>	Pipe thread ISO 228/1	
<b>H</b>	Tapered key shaft 1:8		<b>O</b>	<b>O</b>	Square flange Centering Ø 25.28 mm		<b>02</b>	Thread, metric ISO 9974-1	
<b>N</b>	Dihedral Claw		<b>M</b>	<b>Y</b>	2-bolt mounting Centering Ø 32 mm, with seal ring		<b>20</b>	Rectangular flange	
				<b>Y</b>	2-bolt mounting Centering Ø 32 mm, with seal ring, mounting on series F				

Not all variants can be selected by using the ordering code!  
Please select the required pump by using the selection tables (standard types from standard range, see pages 16...25) or after consultation with Bosch Rexroth!  
Special options are possible upon request.

## Ordering code

External gear units, Multiple pumps, Standard

AZ	P	BB	-	x	x	-	4.0/4.0	R	H	O	20	20	K	B						
<b>Function</b> P = Pump <b>Series</b> B = 1.0...7.1 cm <sup>3</sup> /rev S = 4.0...28 cm <sup>3</sup> /rev F = 4.0...28 cm <sup>3</sup> /rev J = 12.0...16 cm <sup>3</sup> /rev T = 20.0...36 cm <sup>3</sup> /rev N = 20.0...36 cm <sup>3</sup> /rev U = 22.5...63 cm <sup>3</sup> /rev G = 22.5...63 cm <sup>3</sup> /rev <b>Series</b> , relates to pump section 1 2 = Housing width 110 mm <b>Version</b> , relates to pump section 1 2 = corrosion-resistant, pinned <b>Size</b> as per individual Series <b>Direction of rotation</b> R = Clockwise L = Counterclockwise							<b>Rear cover</b> relates to last pump stage B = Standard <b>Seals</b> M = NBR K = NBR, shaft seal ring pump stage 1 in FKM P = FKM													
<b>Drive shafts</b> relates to pump stage 1 Series B: H Tapered key shaft 1: 8  Suitable front cover O Series F, S, J: C Tapered key shaft 1: 5  B H Tapered key shaft 1: 8  O R Splined shaft SAE J 744 16-4 9T  R Series N, T: C Tapered key shaft 1: 5  B D Splined shaft SAE J 744 22-4 13T  C Series G, U: C Tapered key shaft 1: 5  B D Splined shaft SAE J 744 22-4 13T  C H Tapered key shaft 1: 8  O							<b>Front cover</b> relates to pump stage 1 O Square flange Centering Ø 25.38 mm B Square flange Centering Ø 80 mm  O Square flange Centering Ø 36.47 mm  R SAE J 744 82-2 A Centering Ø 82.55 mm 2-hole mounting  B Square flange Centering Ø 100 mm  C SAE J 744 101-2 B Centering Ø 101.6 mm 2-hole mounting  B Square flange Centering Ø 105 mm  C SAE J 744 101-2 B Centering Ø 101.6 mm 2-hole mounting  O Square flange Centering Ø 50.78 mm 							<b>Line ports</b> every pump stage 01 Pipe thread ISO 228/1  20 Rectangular flange  20 Rectangular flange  30 Rectangular flange  07 Square flange SAE thread, metric  20 Rectangular flange  07 Square flange SAE thread, metric  20 Rectangular flange  30 Rectangular flange 						

Not all variants can be selected by using the ordering code!  
 Please select the required pump by using the selection tables (standard types from standard range, see pages 16...25)  
 or after consultation with Bosch Rexroth!  
 Special options are possible upon request.

## Drive shafts

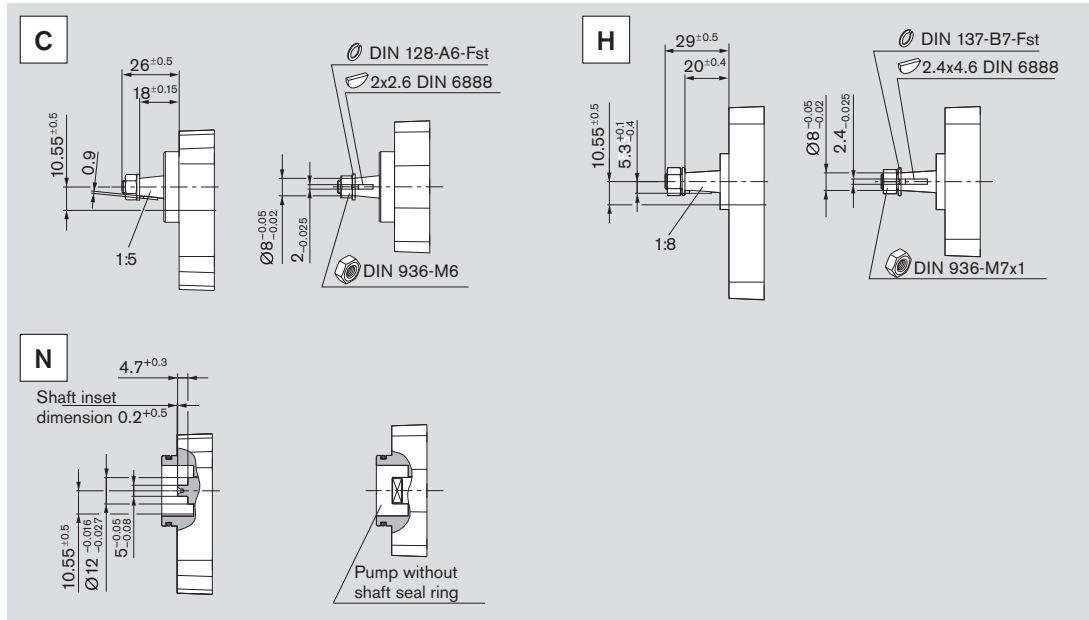

## Front cover

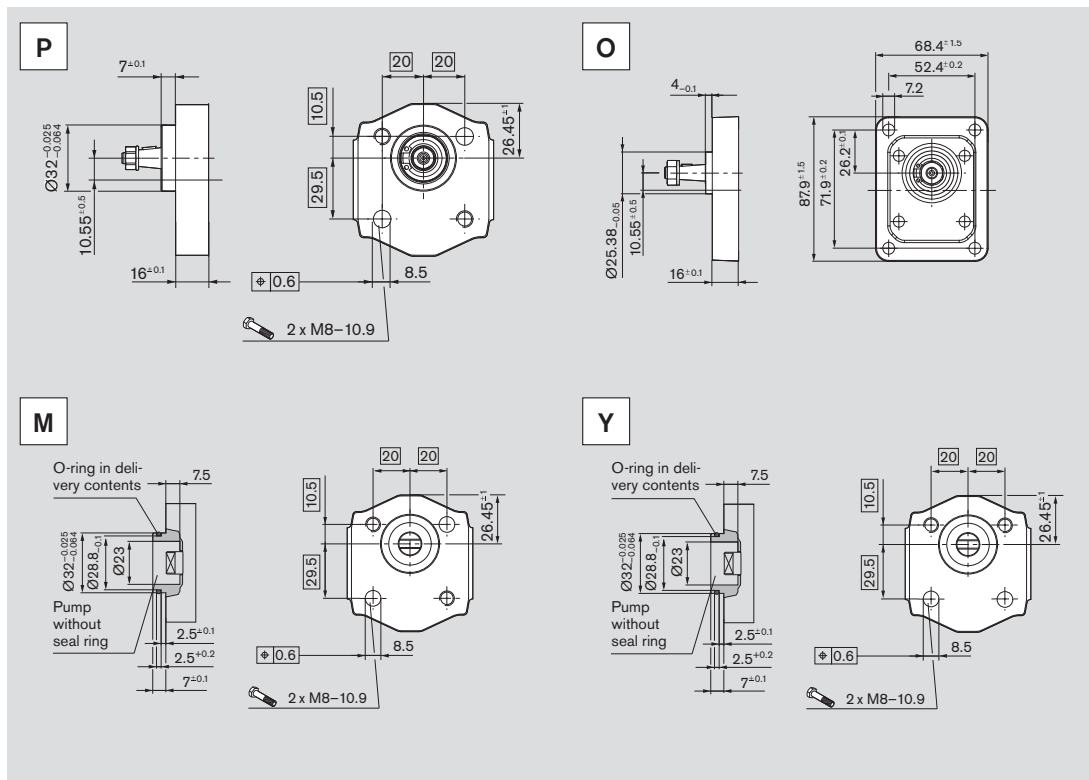

## Line ports

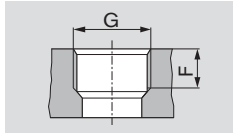

**01** Pipe thread  
ISO 228/1

Limited service life  
compared to line port **20**

Ordering code	Size	Pressure side		Suction side	
		G	F	G	F
01	1...3.15 cm <sup>3</sup>	G 3/8	13	G 3/8	13
	4.0...7.1 cm <sup>3</sup>	G 3/8		G 1/2	13

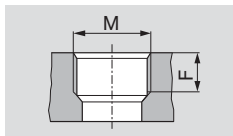

**02** Pipe thread  
ISO 9974-1

Limited service life  
compared to line port **20**

Ordering code	Size	Pressure side		Suction side	
		M	F	M	F
02	1...3.15 cm <sup>3</sup>	14 x 1.5	13	M18 x 1.5	13
	4...7.1 cm <sup>3</sup>			M22 x 1,5	

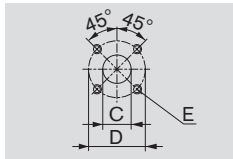

**20** Rectangular flange

Ordering code	Size	Pressure side			Suction side		
		C	D	E	C	D	E
20	2...2.5 cm <sup>3</sup>	12	30	M6 depth 13	12	30	M6 depth 11.5
	3.15...7.1 cm <sup>3</sup>	15	35		15	35	

## Gear pumps with integrated pressure-relief valve

In order to reduce external pipework it is possible to incorporate a pressure-relief valve in the cover of the gear pump.

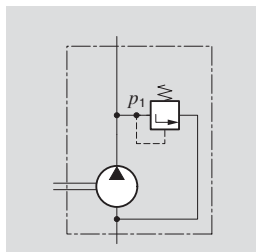

Pressure-relief valve.  
Discharge returned to suction line  
 $p_1 = 5...250$  bar

## Performance charts

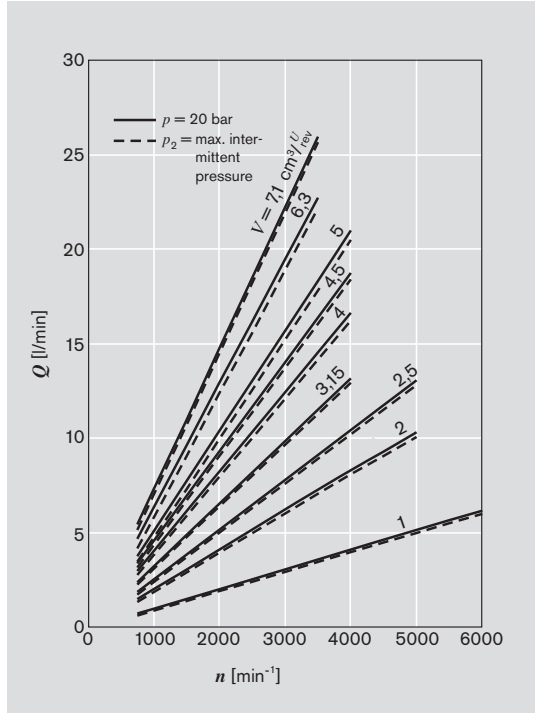

$\nu = 35 \text{ mm}^2/\text{s}, \vartheta = 50^\circ\text{C}$

$Q = f(n, V)$  incl.  $\eta_v$   
 $P = f(n, p)$  — incl.  $\eta_t$   
 $M = f(n, p)$  - - - incl.  $\eta_{hm}$

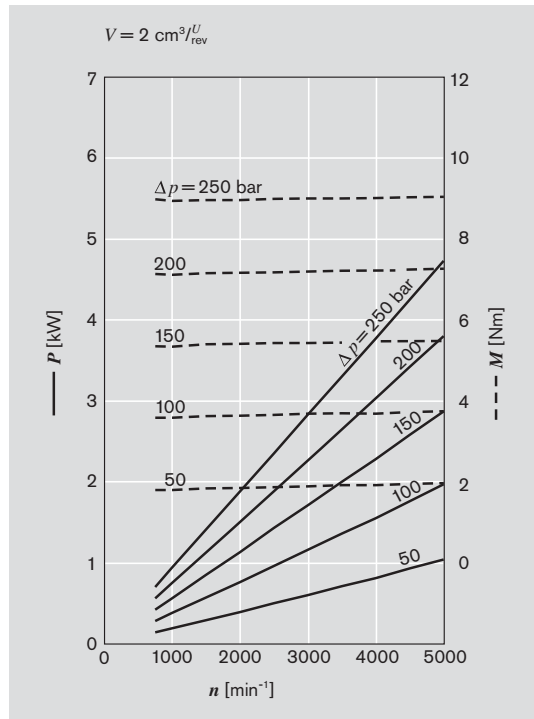
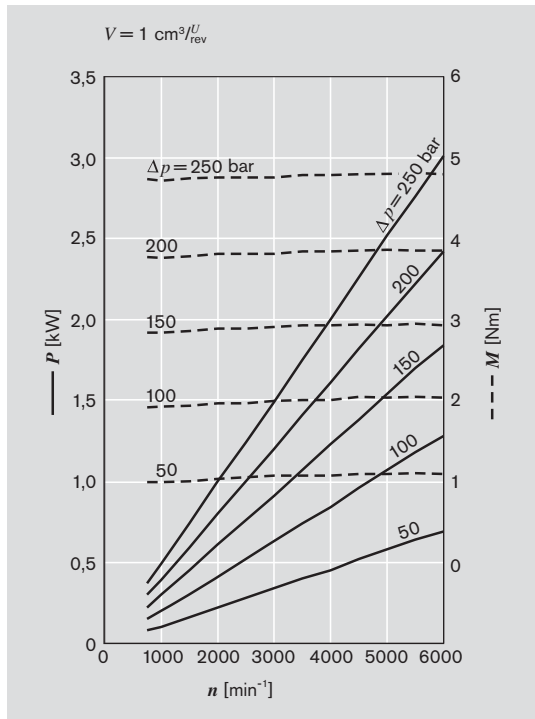

Performance charts (continued)

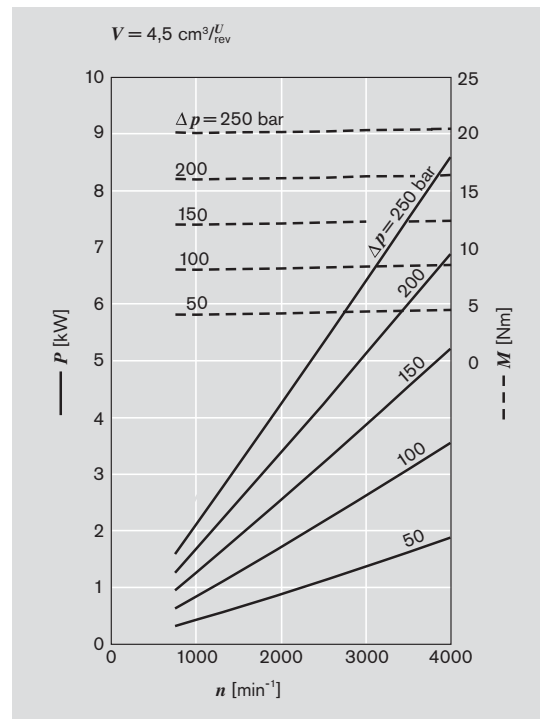
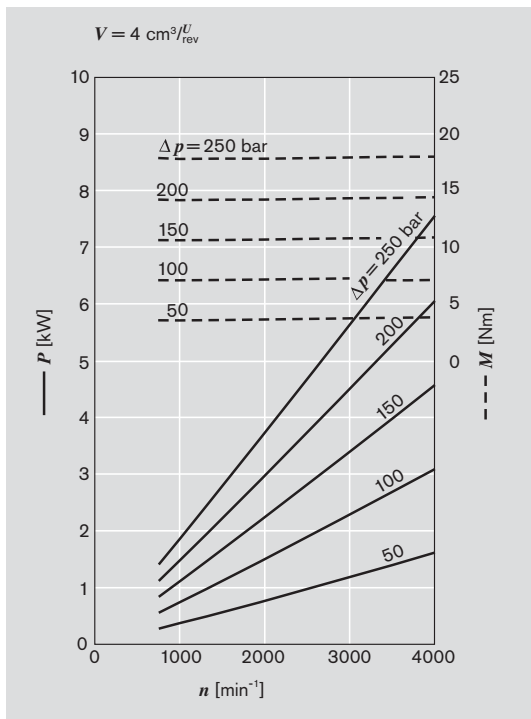
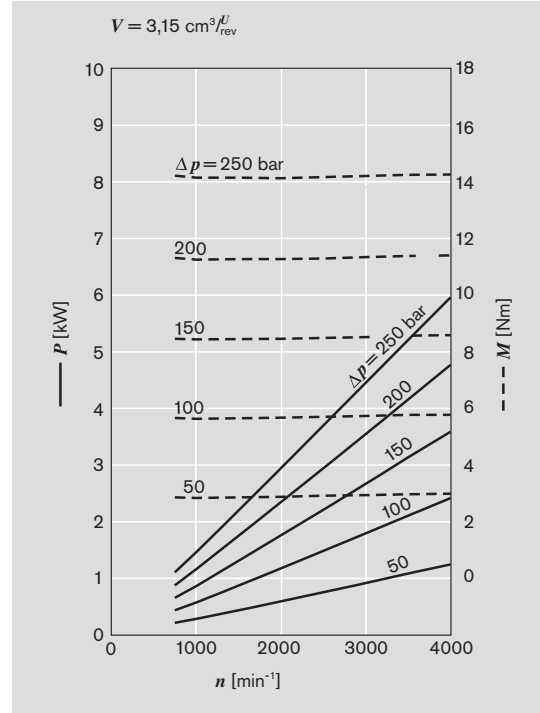
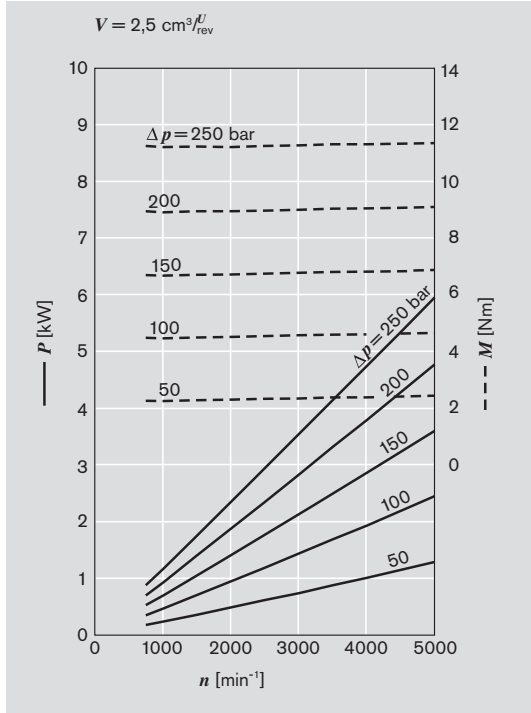

Performance charts (continued)

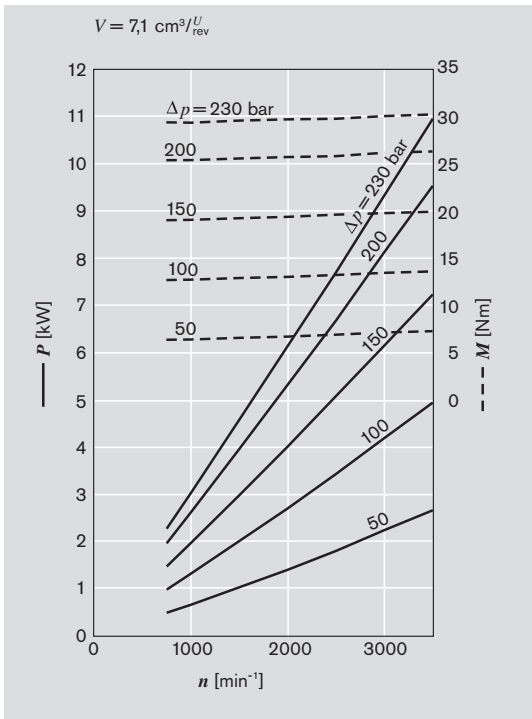
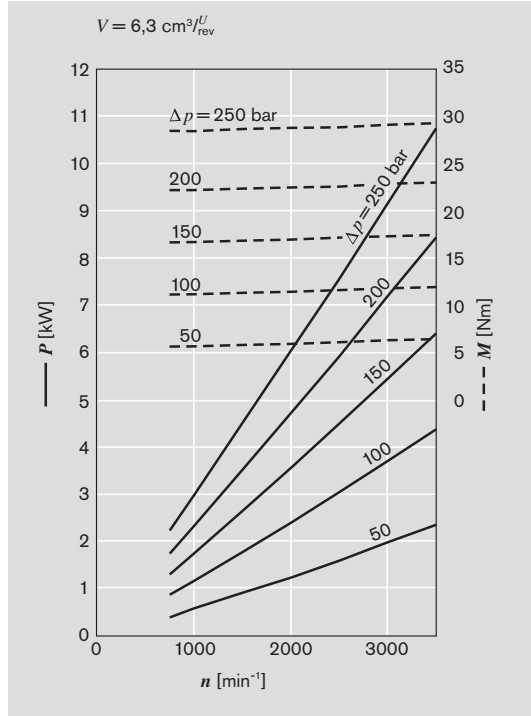
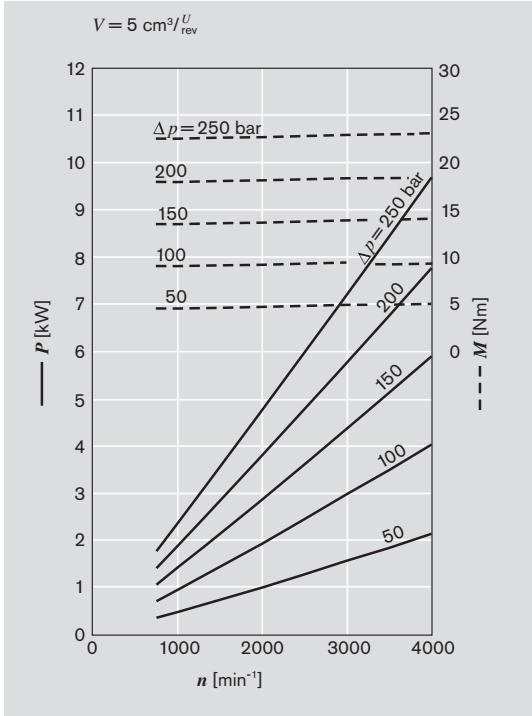

## Noise charts

**Noise level** depending on the rotational speed, pressure range between 10 bar and pressure value  $p_2$  (see page 13 Specifications table).

Oil data:  $\nu = 32 \text{ mm}^2/\text{s}$ ,  $\vartheta = 50^\circ\text{C}$ .

Sound pressure level calculated from noise measurements made in the sound absorbent measuring room compliant with DIN 45635, Part 26.

Distance between measuring instrument – pump: 1 m.

These are typical characteristic values for the respective pump size.

They describe the airborne sound emitted solely by the pump. Environmental influences (installation site, piping, further system components) are not taken into consideration. Each value applies for a single pump.

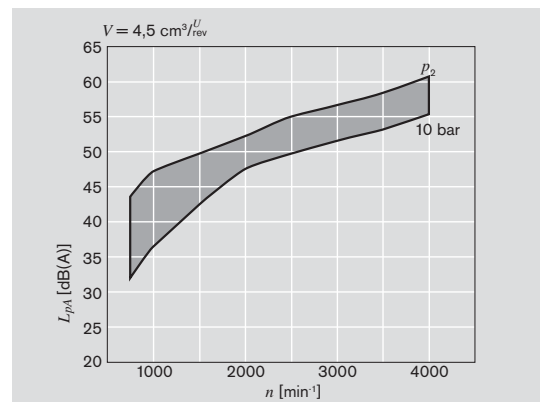
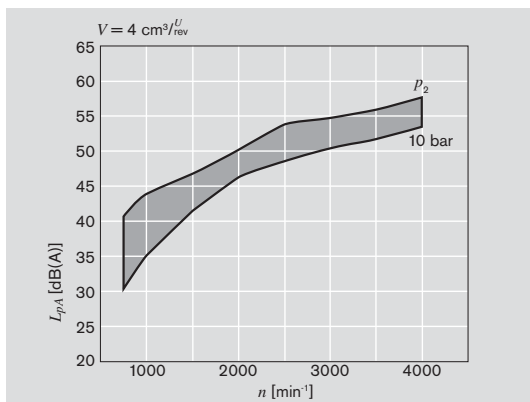
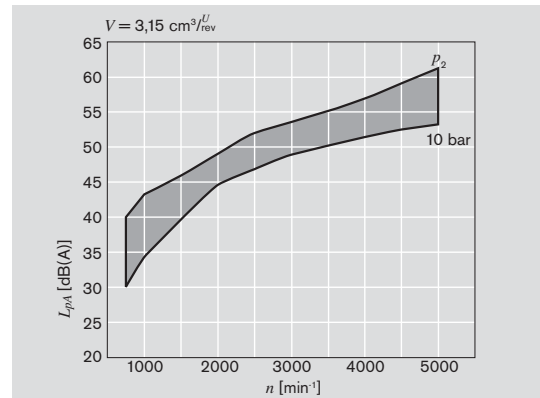
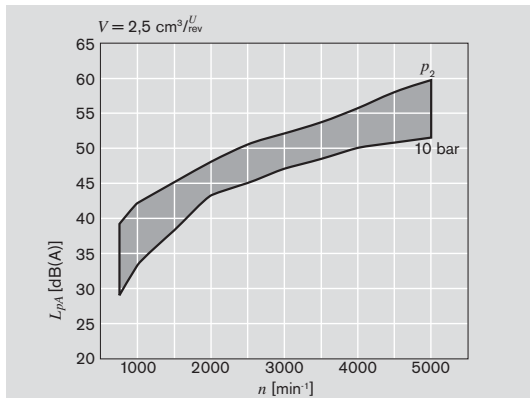
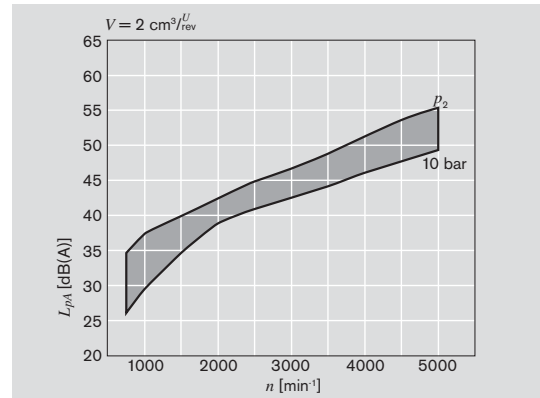
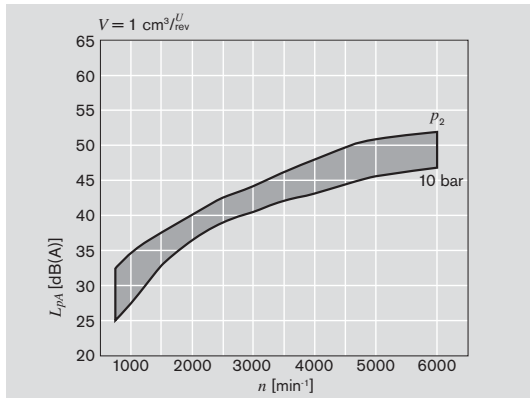

## Noise charts (continued)

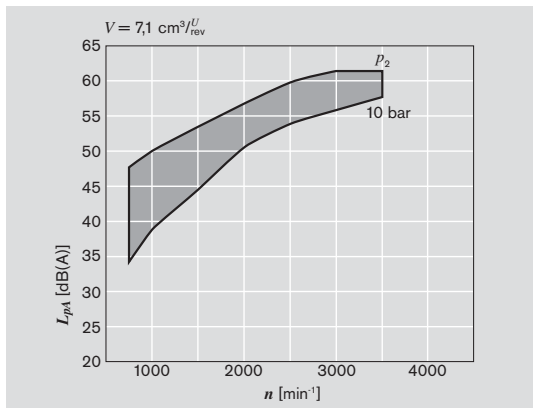
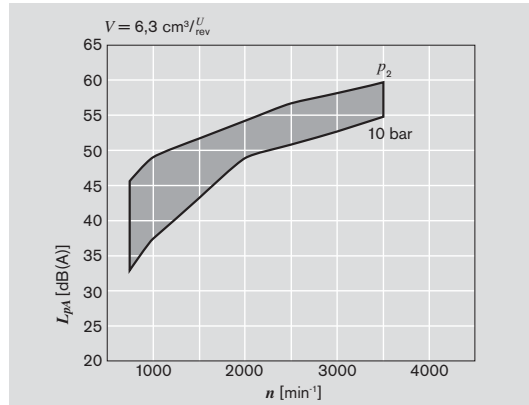
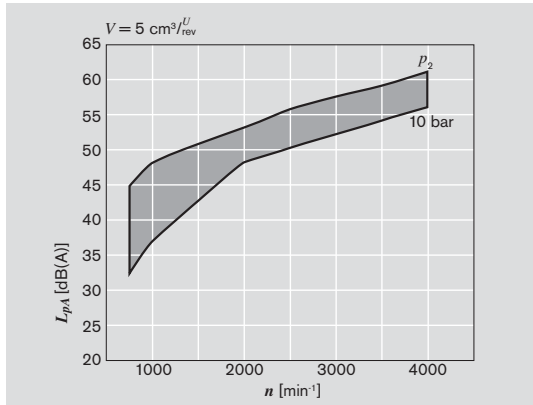

## Design calculations for pumps

The design calculations for pumps are based on the following parameters:

$V$ [cm <sup>3</sup> /rev]	Displacement
$Q$ [l/min]	Delivery
$p$ [bar]	Pressure
$M$ [Nm]	Drive torque
$n$ [rev/min]	Drive speed
$P$ [kW]	Drive power

It is also necessary to allow for different efficiencies such as:

$\eta_v$	Volumetric efficiency
$\eta_{hm}$	Hydraulic-mechanical efficiency
$\eta_t$	Overall efficiency

The following formulas describe the various relationships.

They include correction factors for adapting the parameters to the usual units encountered in practice.

**Caution:** Diagram for approximate selection data can be found on pages 8...10.

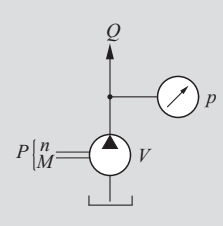

$$Q = V \cdot n \cdot \eta_v \cdot 10^{-5}$$

$$p = \frac{M \cdot \eta_{hm}}{1.59 \cdot V}$$

$$P = \frac{p \cdot Q}{6 \cdot \eta_t}$$

$$V = \frac{Q}{n \cdot \eta_v} \cdot 10^5$$

$$V = \frac{M \cdot \eta_{hm}}{159 \cdot p}$$

$$Q = \frac{6 \cdot P \cdot \eta_t}{p}$$

$$n = \frac{Q}{V \cdot \eta_v} \cdot 10^5$$

$$M = \frac{1.59 \cdot V \cdot p}{\eta_{hm}}$$

$$p = \frac{6 \cdot P \cdot \eta_t}{Q}$$

[%]

$n$	→ $\eta_v$	→ $Q$	$V$ [cm <sup>3</sup> /rev]	$Q$ [l/min]	$p$ [bar]
$M$	→ $\eta_{hm}$	→ $p$	$n$ [rev/min]	$P$ [kW]	$M$ [Nm]
$P$	→ $\eta_t$	→ $p \cdot Q$			

**Caution:**  $\eta$  [%] e.g. 95 [%]

## Specification

General	
Construction	External gear pump
Mounting	Flange or through-bolting with spigot
Line ports	Flange or thread
Direction of rotation (looking on shaft)	Clockwise or counter-clockwise; the pump may only be driven in the direction indicated
Installation position	Any
Load on shaft	Radial and axial forces only after consulting
Ambient temperature range	-30°C...+80°C with NBR seals or -20°C...+110°C with FKM seals
Hydraulic fluid	- Mineral oil compliant with DIN 51 524, 1-3, however under higher load at least HLP compliant with DIN 51 524 Part 2 recommended. - Comply with RE 90220 - Further operating fluids possible after consultation
Viscosity	12...800 mm <sup>2</sup> /s permitted range 20...100 mm <sup>2</sup> /s recommended range ...2000 mm <sup>2</sup> /s range permitted for starting
Hydraulic fluid temperature range	max. +80°C with NBR seals *) max. +110°C with FKM seals **)
Filtration ***)	At least cleanliness level 20/18/15 compliant with ISO 4406 (1999)
Efficiency	on request, depending on load cycle
Service life	on request, depending on load cycle

\*) NBR = Perbunan®

\*\*) FKM = Viton®

\*\*\*) On hydraulic systems or devices with critical counter-reaction, such as steering and counterbalance valves, the type of filtration selected must be adapted to the sensitivity of these devices/systems.

Safety requirements pertaining to the whole systems are to be observed.

In the case of applications with high numbers of load cycles please consult Bosch Rexroth.

### Definition of direction of rotation

Always look on the drive shaft.

**Caution:** Dimensional drawings always show clockwise-rotating pumps. For counterclockwise-rotating pumps the positions of the drive shaft and the suction and pressure ports are different.

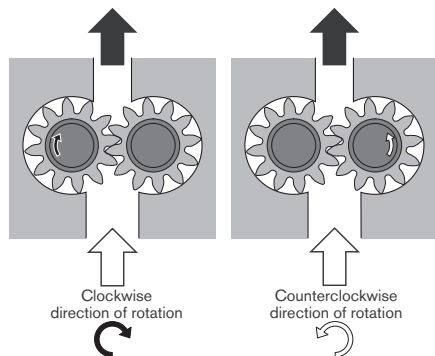

### Definitions of pressures

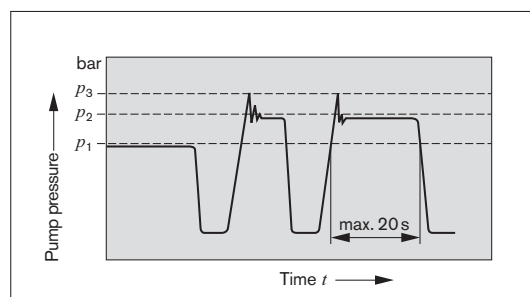

$p_1$  max. continuous pressure  
 $p_2$  max. intermittent pressure  
 $p_3$  max. peak pressure

### AZPB-3x

Displacement	V	cm <sup>3</sup> /rev	1	2	2.5	3.15	4	4.5	5	6.3	7.1
Suction pressure	$p_e$	bar	0.7...3 (absolute)								
max. continuous pressure	$p_1$		220	220	220	220	220	220	220	220	200
max. intermittent pressure	$p_2$		250	250	250	250	250	250	250	250	230
max. peak pressure	$p_3$		270	270	270	270	270	270	270	270	250
min. rotational speed		rpm	750	750	750	750	750	750	750	750	750
max. rotational speed at	$p_2$		6,000	5,000	5,000	4,000	4,000	4,000	4,000	3,500	3,500

Project planning up to 280 bar ( $p_2$ ) possible in agreement with Product Management, External Gear Units.

## Drive arrangement

The coupling must not transfer any radial or axial forces to the pump.

### 1. Flexible couplings

Refer to the fitting instructions provided by the coupling manufacturer for details of the maximum permitted shaft misalignment.

The maximum radial runout from the pump shaft to the spigot is 0.2 mm.

### 2. Drive shaft with tang

For directly mounting the pump to an electric motor or an internal-combustion engine, gear, etc. the pump shaft has a special tang and driver (3) (not included in delivery). There is no shaft sealing.

The recommended arrangements and dimensions for the drive end and sealing are as follows.

Transferrable torque:

AZPB-3x = 25 Nm.

Suitable couplings for AZPB-3x:

1 510 001 002 for AZPFB,

1 510 240 001 for AZPBB.

#### ① Drive shaft

Case-hardening steel DIN 17 210

e.g. 20 MnCrS 5

case-hardened 1.0 deep; HRA 83 $\pm$ 2

Surface for sealing ring  
ground without rifling  $R_t \leq 4\mu\text{m}$

#### ② Radial shaft seal

with rubber covered seal  
(see DIN 3760, Type AS, or  
double-lipped ring).

Please take note of the seal ring  
manufacturer's guidelines for arrange-  
ment of the installation space.

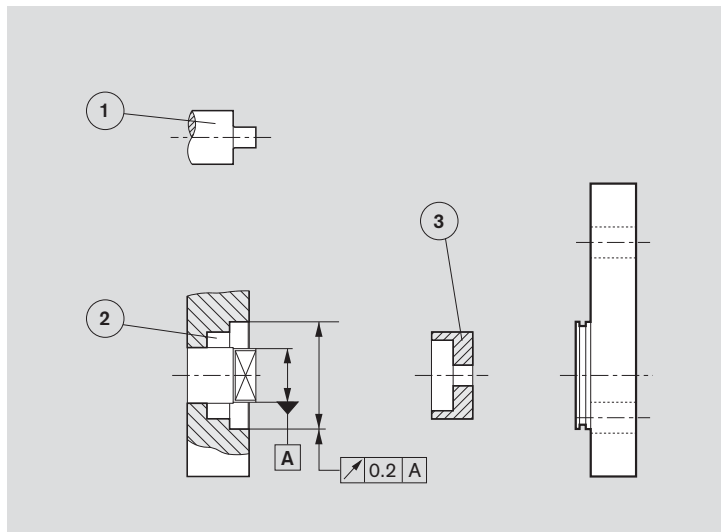
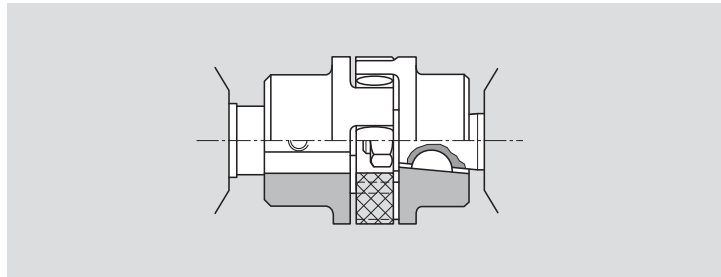

## Multiple gear pumps

Gear pumps are suitable for multiple setups, whereby the drive shaft for the 1<sup>st</sup> pump is extended to a second and even a 3<sup>rd</sup> pump. A coupling is fitted between each pair of pumps.

In most cases each pump is isolated from its neighbor, i.e. the suction ports are separate from one another. A common suction port is also possible as an option.

**Caution:** Basically, the specifications for the single pumps apply, but with certain restrictions:

**Max. speed:** This is determined by the highest rated pump speed in use.

**Pressures:** These are restricted by the strength of the drive shaft, the through drives and the drivers. Appropriate data is given in the dimensional drawings.

### Pressure restrictions

In the case of series B (AZPB-3x), the driver for the second pumping stage can carry a load of up to  $M_{max.} = 25$  Nm, i.e. there is a pressure restriction for the second stage and any further stages.

Drive shaft		max. transferrable drive torque * [Nm]
C	1:5	26
H	1:8	30
N	Claw	25

\* These values only apply when the conditions described above are complied with. Bosch Rexroth is to be consulted if the stated values are exceeded.

If the first stage is driven through a tang (driver) or outboard bearing type 1, pressure restrictions apply as indicated in the formula below.

Reinforced through drives are available for applications with higher transfer torques and/or rotational vibrations. Customized designs available on request.

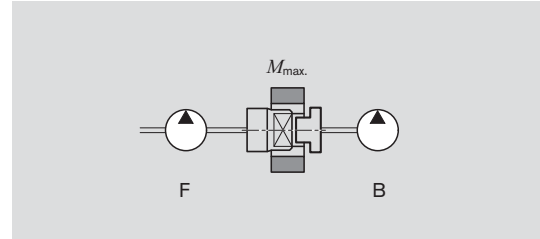

### Combinations

Series Pump 1	$M_{max.}$ [Nm]	Series Pump 2
F	25	B
B	25	B

When configuring multiple pumps, the pumps are to be ordered according to the largest displacement on the drive side, e.g. BB, FB, SB, JB as double, FBB, SBB, JBB, NFB, GFB, TSB, USB as triple.

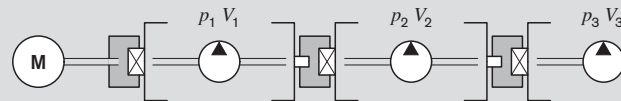

$$M_{max.} \cong \Delta p_1 \cdot V_1 \cdot 0,0177 + \Delta p_2 \cdot V_2 \cdot 0,0177 + \Delta p_3 \cdot V_3 \cdot 0,0177$$

$\Delta p$  [bar]  $V$  [cm<sup>3</sup>/rev]

## Dimensions

### Standard range

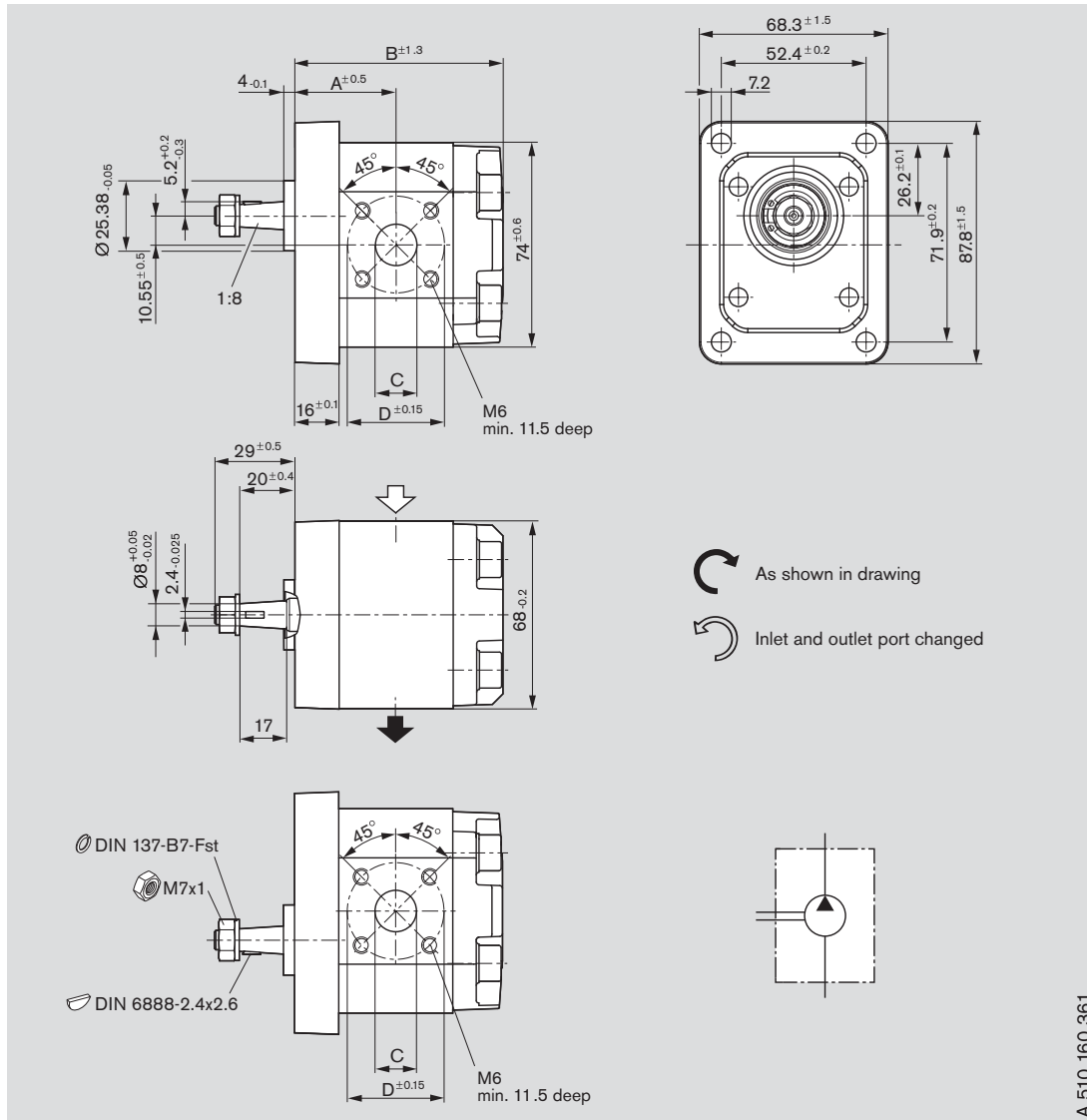

A 510 160 361

### Ordering code:

AZPB - 32 -     H O 20 M B

Displacement [cm <sup>3</sup> /rev]	Ordering-No.		max. operating pressure [bar]	max. rotation speed [rpm]	Mass [kg]	Dimension [mm]			
	L	R				A	B	C	D
2	0 510 120 326	0 510 120 028	250	5,000		32.8	67.9	12	30
2.5	0 510 120 327	0 510 120 029	250	5,000		33.8	69.8	12	30
3.15	0 510 120 328	0 510 120 030	250	4,000		35.0	72.3	15	35
4	0 510 120 329	0 510 120 031	250	4,000		36.6	75.5	15	35
4.5	0 510 120 330	0 510 120 032	250	4,000		37.6	77.4	15	35
5	0 510 120 331	0 510 120 033	250	4,000		38.6	79.5	15	35
6.3	0 510 120 332	0 510 120 034	250	3,500		41.0	84.2	15	35
7.1	0 510 120 333	0 510 120 035	230	3,500		42.5	87.3	15	35

## Dimensions

### Standard range

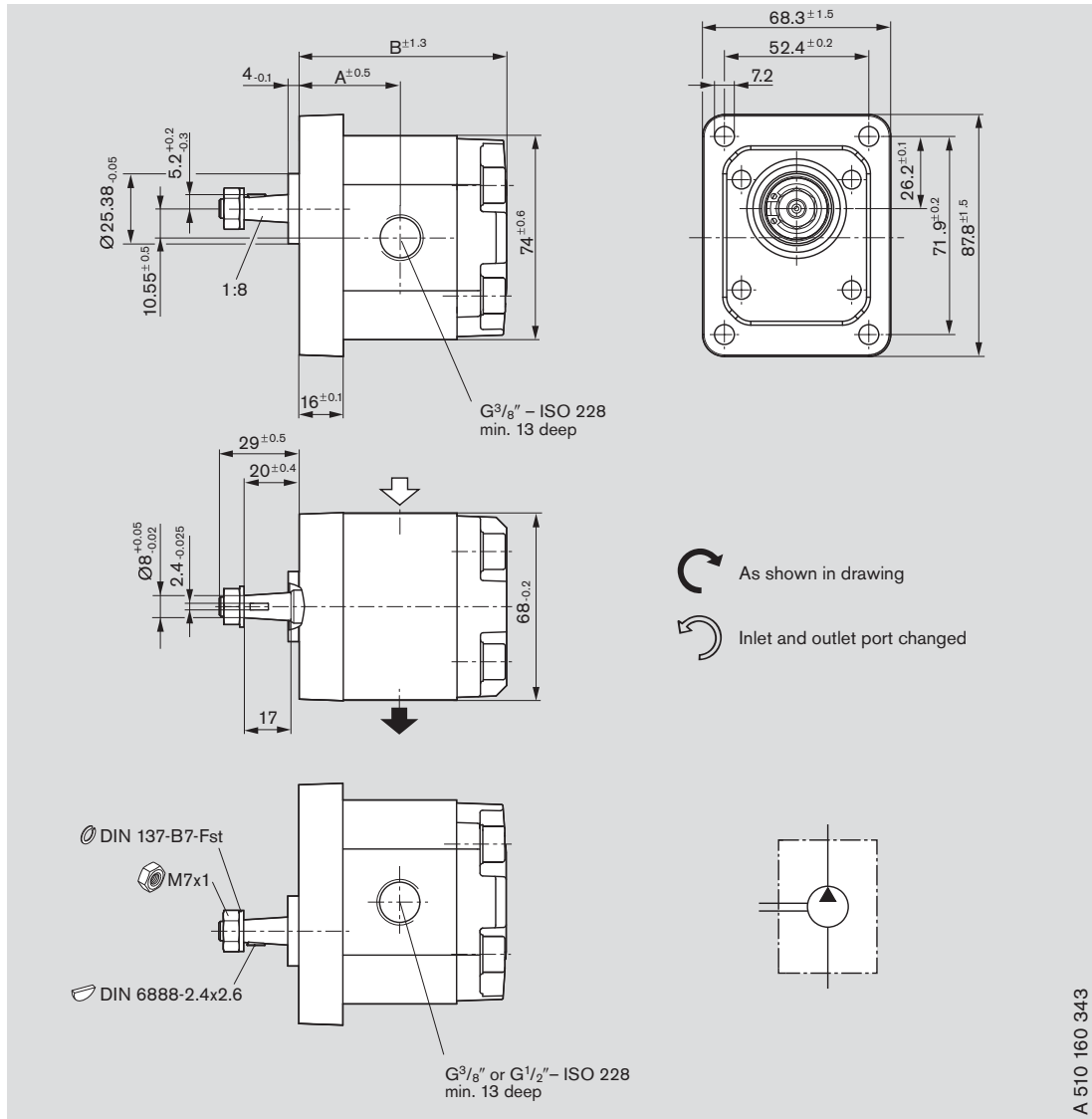

### Ordering code:

AZPB - 32 -     H O 01 M B

Displacement [cm <sup>3</sup> /rev]	Ordering-No.		max. operating pressure [bar]	max. rotation speed [rpm]	Mass [kg]	Dimension [mm]		
	L	R				A	B	Version
1	0 510 020 303	0 510 020 003	250	6,000		30.9	64.1	$3/8$
2	0 510 120 318	0 510 120 020	250	5,000		32.8	67.9	$3/8$
2.5	0 510 120 319	0 510 120 021	250	5,000		33.8	69.8	$3/8$
3.15	0 510 120 320	0 510 120 022	250	4,000		35.0	72.3	$3/8$
4	0 510 120 321	0 510 120 023	250	4,000		36.6	75.5	$1/2$
4.5	0 510 120 322	0 510 120 024	250	4,000		37.6	77.4	$1/2$
5	0 510 120 323	0 510 120 025	250	4,000		38.6	79.5	$1/2$
6.3	0 510 120 324	0 510 120 026	250	3,500		41.0	84.2	$1/2$
7.1	0 510 120 325	0 510 120 027	230	3,500		42.5	87.3	$1/2$

## Dimensions

### Standard range

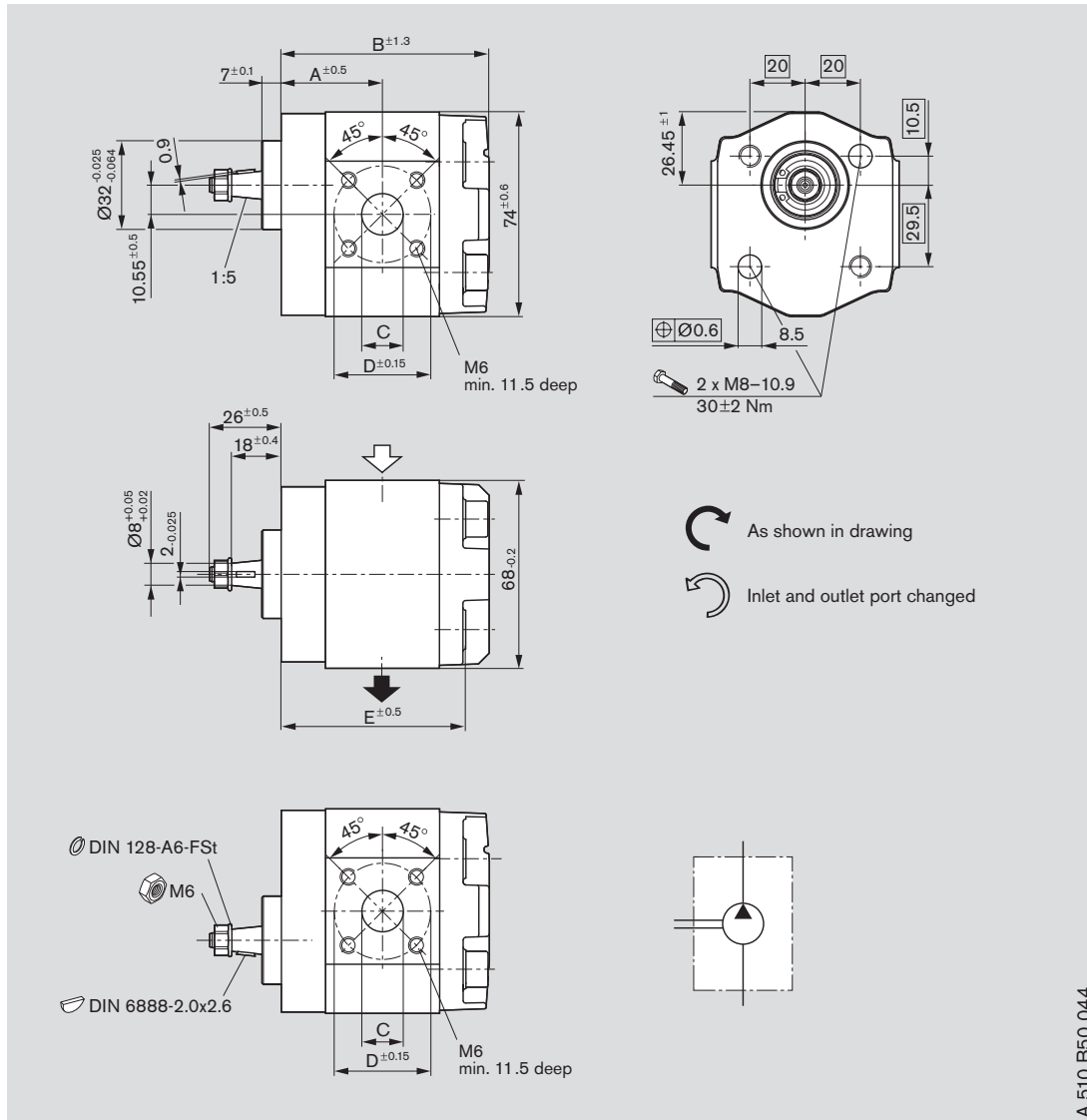

A 510 B50 044

### Ordering code:

AZPB - 32 -     C P 20 M B

Displacement [cm <sup>3</sup> /rev]	Ordering-No.		max. operating pressure [bar]	max. rotation speed [rpm]	Mass [kg]	Dimension [mm]				
	L	R				A	B	C	D	E
2	0 510 110 332	0 510 110 025	250	5,000		32.8	67.9	12	30	59.0
2.5	0 510 110 333	0 510 110 026	250	5,000		33.8	69.8	12	30	60.9
3.15	0 510 112 325	0 510 112 019	250	4,000		35.0	72.3	15	35	63.4
4	0 510 114 336	0 510 114 030	250	4,000		36.6	75.5	15	35	66.6
4.5	0 510 114 337	0 510 114 031	250	4,000		37.6	77.4	15	35	68.5
5	0 510 114 338	0 510 114 032	250	4,000		38.6	79.5	15	35	70.6
6.3	0 510 122 324	0 510 122 020	250	3,500		41.0	84.2	15	35	75.3
7.1	0 510 122 325	0 510 122 021	230	3,500		42.5	87.3	15	35	78.4

## Dimensions

### Standard range

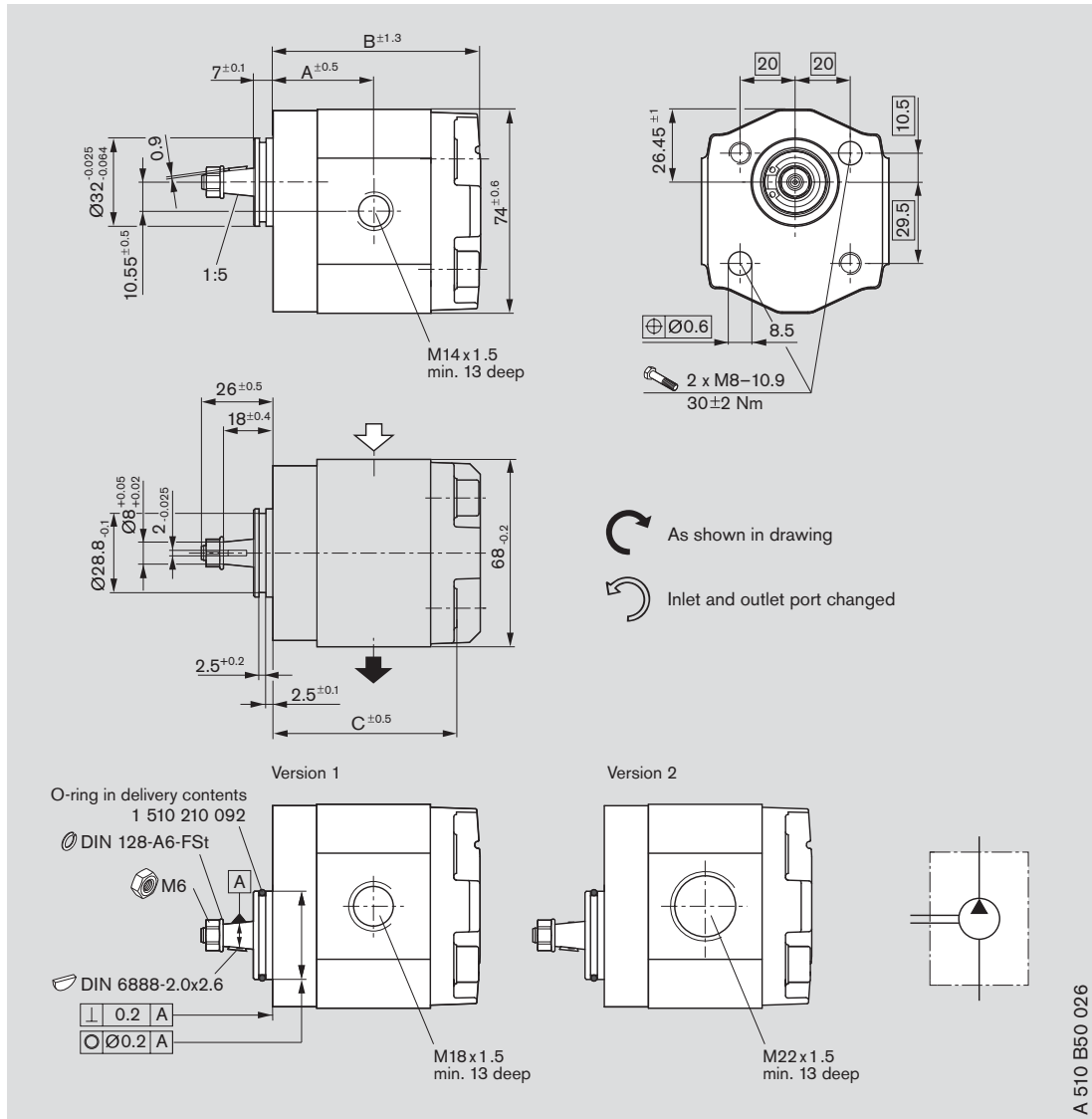

### Ordering code:

AZPB - 32 -     C P 02 M B

Displacement [cm <sup>3</sup> /rev]	Ordering-No.		max. operating pressure [bar]	max. rotation speed [rpm]	Mass [kg]	Dimension [mm]			Version
						A	B	C	
1	0 510 010 315	0 510 010 010	250	6,000		30.9	64.1	55.2	1
2	0 510 110 328	0 510 110 022	250	5,000		32.8	67.9	59.0	1
2.5	0 510 110 329	0 510 110 023	250	5,000		33.8	69.8	60.9	1
3.15	0 510 112 323	0 510 112 018	250	4,000		35.0	72.3	63.4	1
4	0 510 114 330	0 510 114 025	250	4,000		36.6	75.5	66.6	2
4.5	0 510 114 331	0 510 114 026	250	4,000		37.6	77.4	68.5	2
5	0 510 114 332	0 510 114 027	250	4,000		38.6	79.5	70.6	2
6.3	0 510 122 320	0 510 122 016	250	3,500		41.0	84.2	75.3	2
7.1	0 510 122 321	0 510 122 017	230	3,500		42.5	87.3	78.4	2

## Dimensions

### Standard range

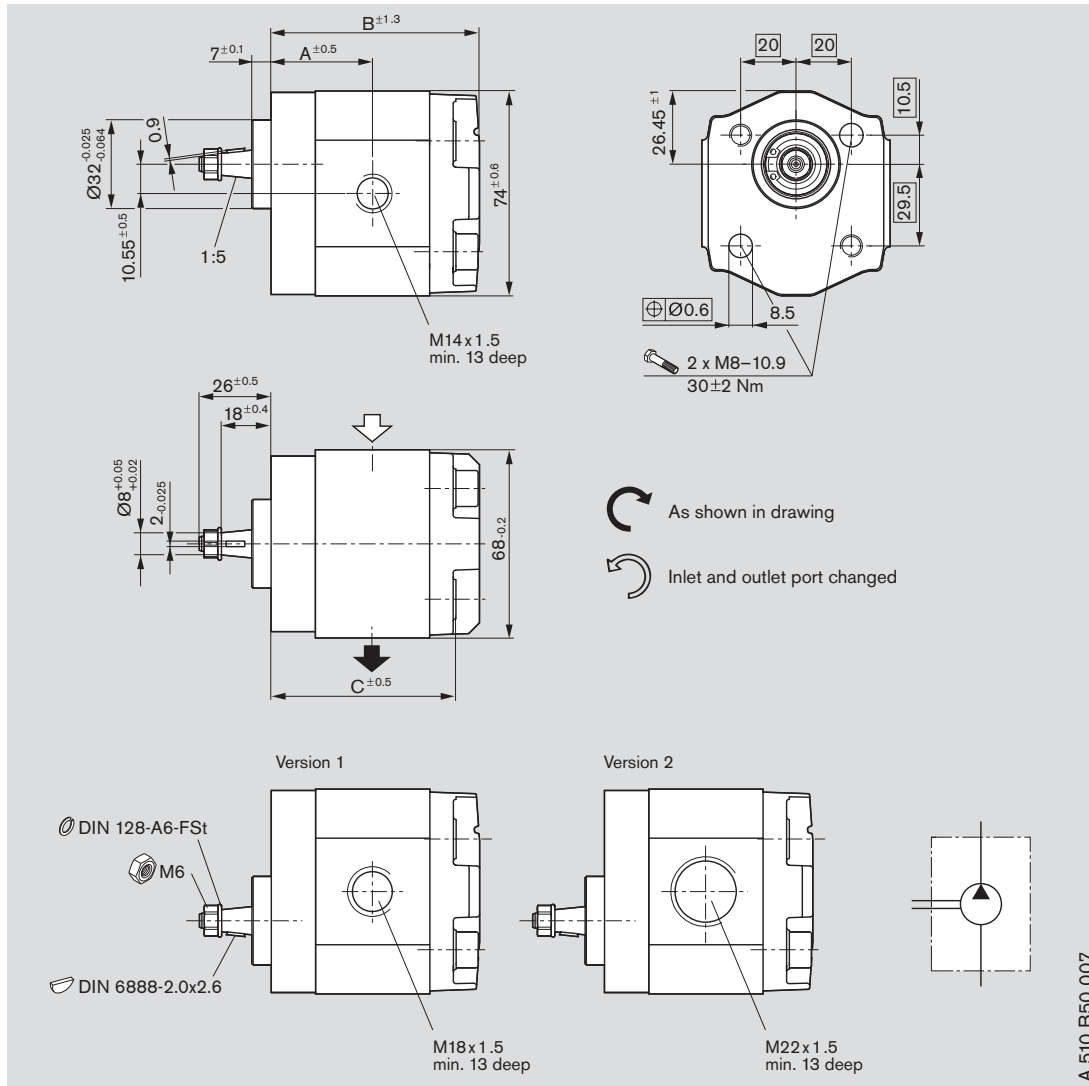

### Ordering code:

AZPB - 32 -     C P 02 M B  
AZPB - 32 -     C P 02 K B\*

Displacement [cm <sup>3</sup> /rev]	Ordering-No.		max. operating pressure [bar]	max. rotation speed [rpm]	Mass [kg]	Dimension [mm]			Version
	L	R				A	B	C	
1	0 510 010 313	0 510 010 008	250	6,000		30.9	64.1	55.2	1
2	0 510 110 324	0 510 110 017	250	5,000		32.8	67.9	59.0	1
2.5	0 510 110 325	0 510 110 018	250	5,000		33.8	69.8	60.9	1
3.15		0 510 112 015*	250	4,000		35.0	72.3	63.4	1
3.15	0 510 112 321	0 510 112 014	250	4,000		35.0	72.3	63.4	1
4	0 510 114 324	0 510 114 018	250	4,000		36.6	75.5	66.5	2
4.5	0 510 114 325	0 510 114 019	250	4,000		37.6	77.4	68.5	2
5	0 510 114 326	0 510 114 020	250	4,000		38.6	79.5	70.6	2
6.3	0 510 122 316	0 510 122 012	250	3,500		41.0	84.2	75.3	2
7.1	0 510 122 317	0 510 122 013	230	3,500		42.5	87.3	78.4	2

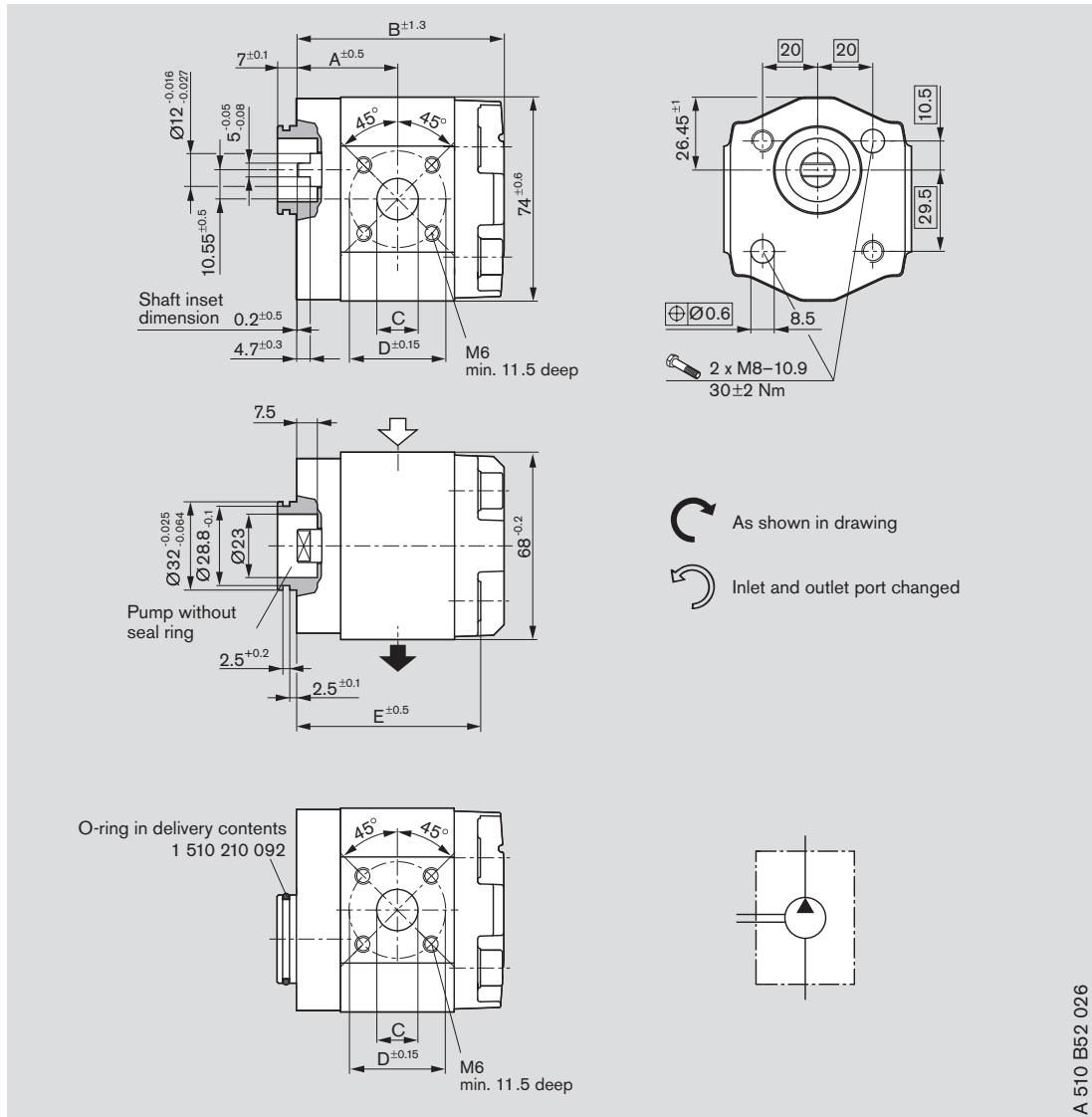

## Dimensions

### Standard range



#### Ordering code:

AZPB - 32 -     N M 20 M B

Displacement [cm <sup>3</sup> /rev]	Ordering-No.		max. operating pressure [bar]	max. rotation speed [rpm]	Mass [kg]	Dimension [mm]				
	 L	 R				A	B	C	D	E
2	0 510 110 334	0 510 110 027	250	5,000		32.8	67.9	12	30	59.0
2.5	0 510 110 335	0 510 110 028	250	5,000		33.8	69.8	12	30	60.9
3.15	0 510 112 326	0 510 112 020	250	4,000		35.0	72.3	15	35	63.4
4	0 510 114 339	0 510 114 033	250	4,000		36.6	75.5	15	35	66.6
4.5	0 510 114 340	0 510 114 034	250	4,000		37.6	77.4	15	35	68.5
5	0 510 114 341	0 510 114 035	250	4,000		38.6	79.5	15	35	70.6
6.3	0 510 122 326	0 510 122 022	250	3,500		41.0	84.2	15	35	75.3
7.1	0 510 122 327	0 510 122 023	230	3,500		42.5	87.3	15	35	78.4

## Dimensions

### Standard range

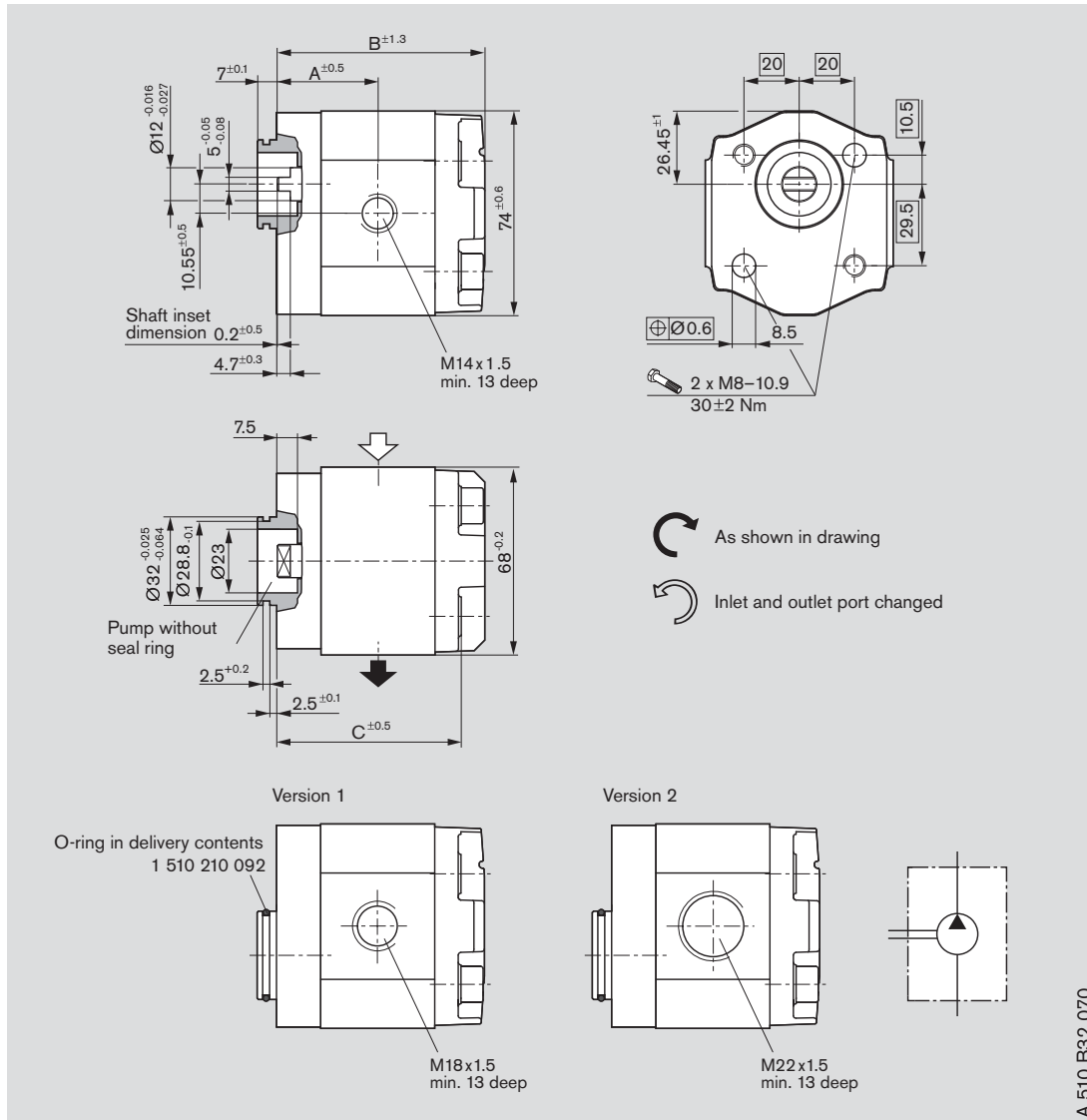

### Ordering code:

AZPB - 32 -     N M 02 M B

Displacement [cm <sup>3</sup> /rev]	Ordering-No.		max. operating pressure [bar]	max. rotation speed [rpm]	Mass [kg]	Dimension [mm]			
	L	R				A	B	C	Version
1	0 510 010 314	0 510 010 009	250	6,000		30.9	64.1	55.2	1
2	0 510 110 326	0 510 110 019	250	5,000		32.8	67.9	59.0	1
2.5	0 510 110 327	0 510 110 020	250	5,000		33.8	69.8	60.9	1
3.15	0 510 112 322	0 510 112 016	250	4,000		35.0	72.3	63.4	1
4	0 510 114 327	0 510 114 021	250	4,000		36.6	75.5	66.6	2
4.5	0 510 114 328	0 510 114 022	250	4,000		37.6	77.4	68.5	2
5	0 510 114 329	0 510 114 023	250	4,000		38.6	79.5	70.6	2
6.3	0 510 122 318	0 510 122 014	250	3,500		41.0	84.2	75.3	2
7.1	0 510 122 319	0 510 122 015	230	3,500		42.5	87.3	78.4	2

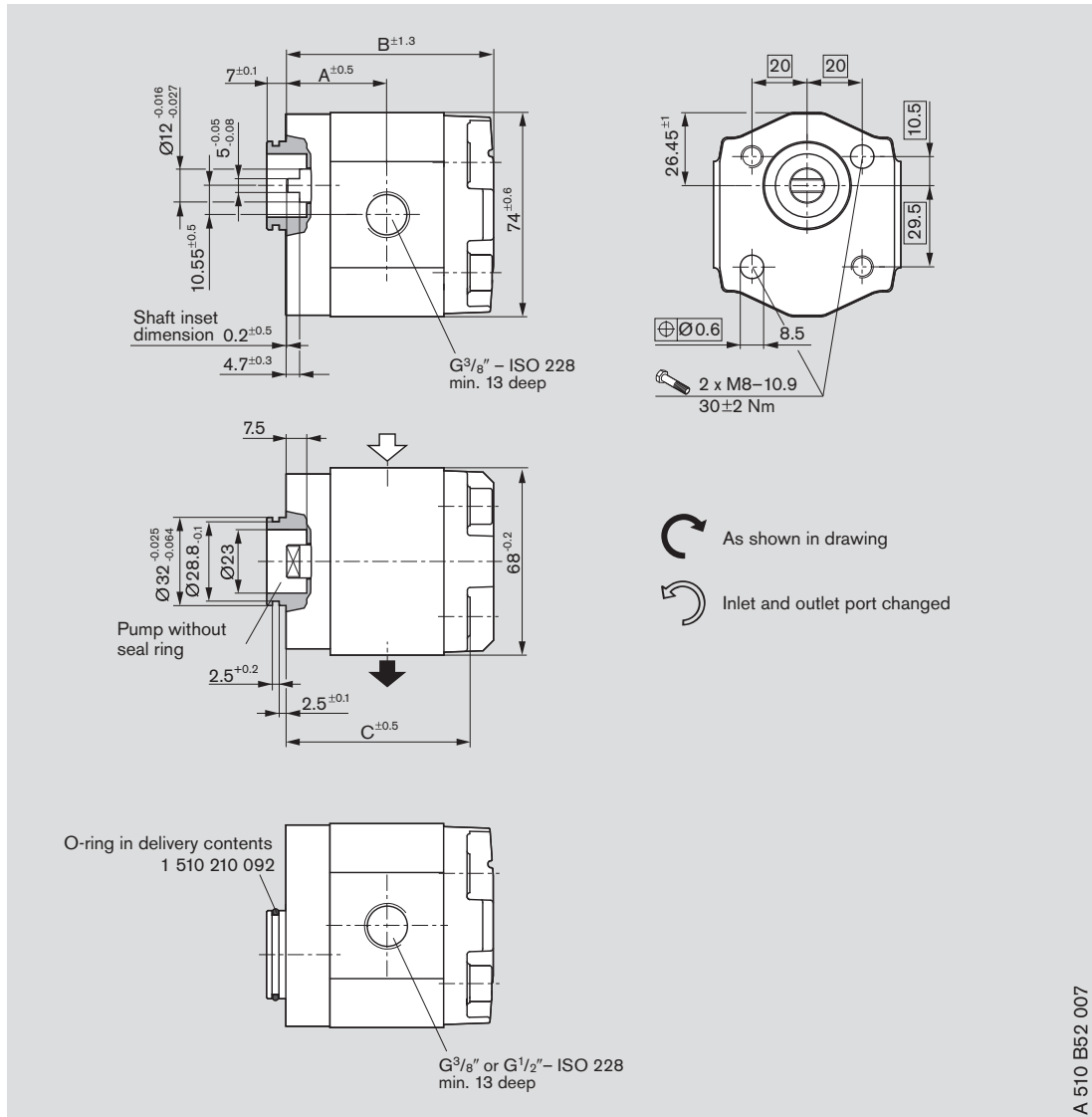

## Dimensions

### Standard range



#### Ordering code:

AZPB - 32 -     N M 01 M B

Displacement [cm <sup>3</sup> /rev]	Ordering-No.		max. operating pressure [bar]	max. rotation speed [rpm]	Mass [kg]	Dimension [mm]			Version
	 L	 R				A	B	C	
1	0 510 010 316	0 510 010 011	250	6,000		30.9	64.1	55.2	$\frac{3}{8}$
2	0 510 110 330	0 510 110 021	250	5,000		32.8	67.9	59.0	$\frac{3}{8}$
2.5	0 510 110 331	0 510 110 024	250	5,000		33.8	69.8	60.9	$\frac{3}{8}$
3.15	0 510 112 324	0 510 112 017	250	4,000		35.0	72.3	63.4	$\frac{3}{8}$
4	0 510 114 333	0 510 114 028	250	4,000		36.6	75.5	66.6	$\frac{1}{2}$
4.5	0 510 114 334	0 510 114 024	250	4,000		37.6	77.4	68.5	$\frac{1}{2}$
5	0 510 114 335	0 510 114 029	250	4,000		38.6	79.5	70.6	$\frac{1}{2}$
6.3	0 510 122 322	0 510 122 018	250	3,500		41.0	84.2	75.3	$\frac{1}{2}$
7.1	0 510 122 323	0 510 122 019	230	3,500		42.5	87.3	78.4	$\frac{1}{2}$

## Dimensions

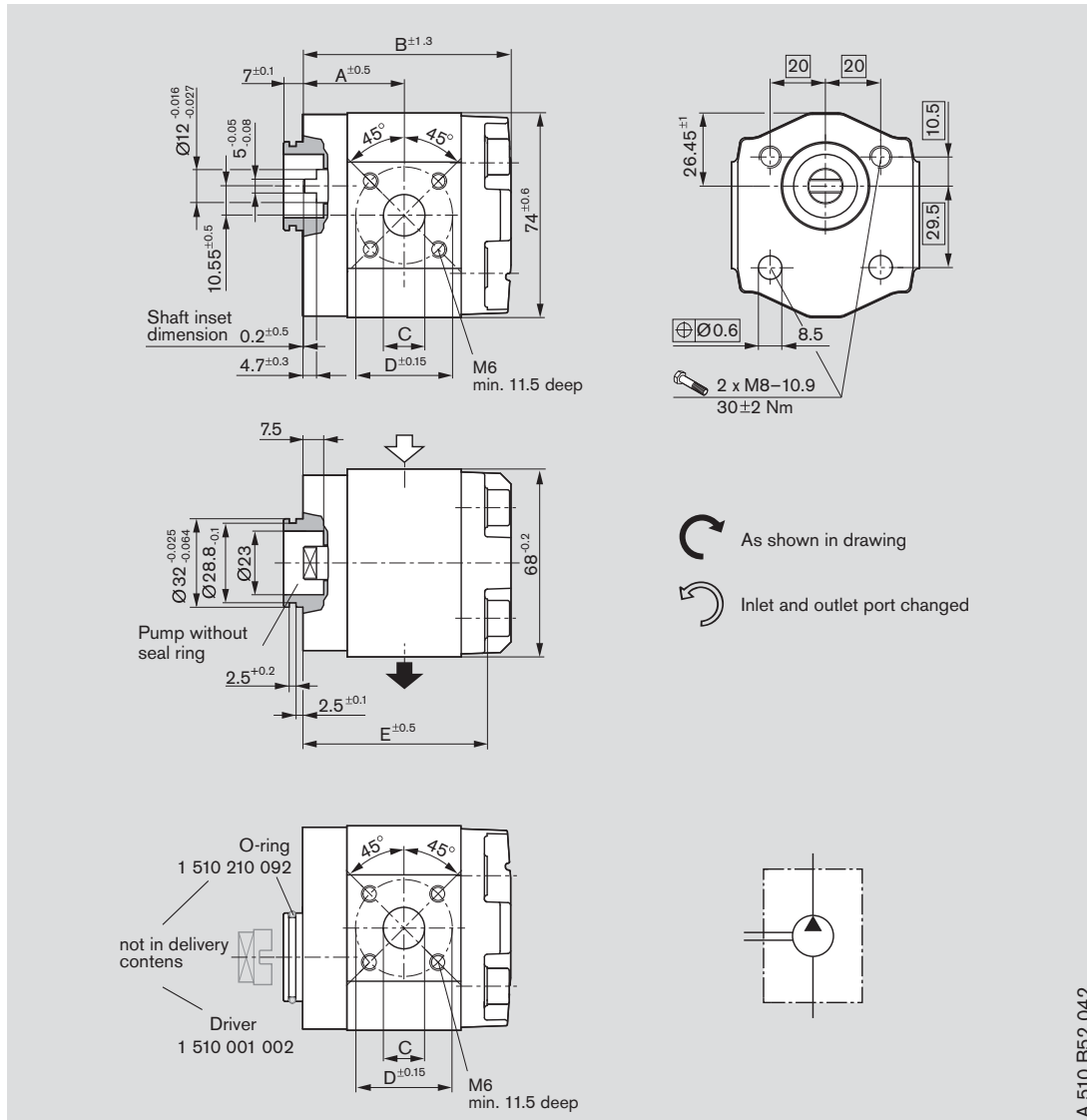

### Standard range



A 510 B52 042

### Ordering code:

AZPB - 32 -     N Y 20 M B

Displacement [cm <sup>3</sup> /rev]	Ordering-No.		max. operating pressure [bar]	max. rotation speed [rpm]	Mass [kg]	Dimension [mm]				
	 L	 R				A	B	C	D	E
2	1 519 222 469	1 519 222 468	250	5,000		32.8	67.9	12	30	59.0
2.5	1 519 222 471	1 519 222 470	250	5,000		33.8	69.8	12	30	60.9
3.15	1 519 222 473	1 519 222 472	250	4,000		35.0	72.3	15	35	63.4
4	1 519 222 475	1 519 222 474	250	4,000		36.6	75.5	15	35	66.6
4.5	1 519 222 477	1 519 222 476	250	4,000		37.6	77.4	15	35	68.5
5	1 519 222 479	1 519 222 478	250	4,000		38.6	79.5	15	35	70.6
6.3	1 519 222 481	1 519 222 480	250	3,500		41.0	84.2	15	35	75.3
7.1	1 519 222 483	1 519 222 482	230	3,500		42.5	87.3	15	35	78.4

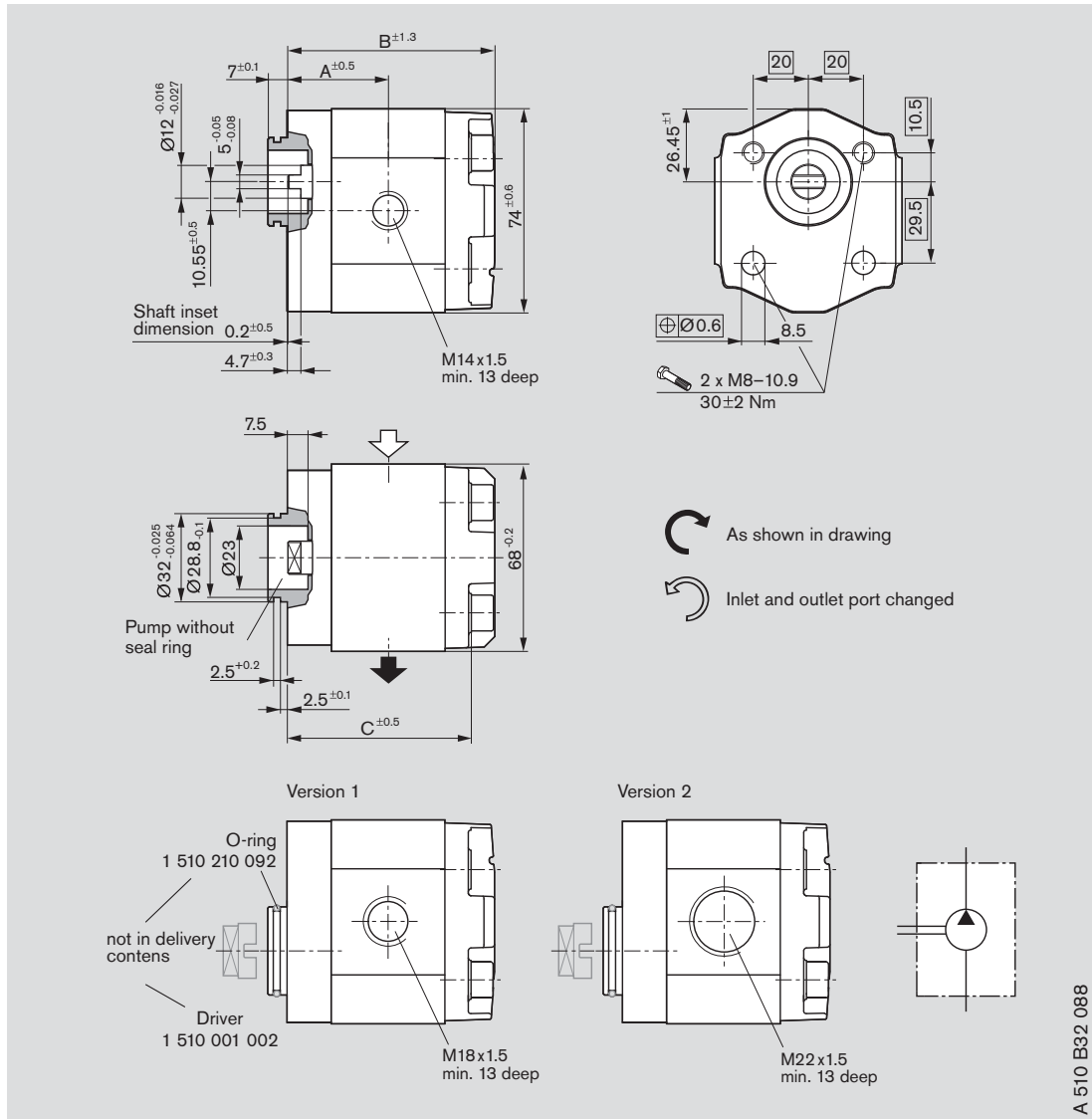

## Dimensions

### Standard range



### Ordering code:

AZPB - 32 -     N Y 02 M B

Displacement [cm <sup>3</sup> /rev]	Ordering-No.		max. operating pressure [bar]	max. rotation speed [rpm]	Mass [kg]	Dimension [mm]			Version
	 L	 R				A	B	C	
1	1 519 222 444	1 519 222 443	250	6,000		30.9	64.1	55.2	1
2	1 519 222 446	1 519 222 445	250	5,000		32.8	67.9	59.0	1
2.5	1 519 222 448	1 519 222 447	250	5,000		33.8	69.8	60.9	1
3.15	1 519 222 450	1 519 222 449	250	4,000		35.0	72.3	63.4	1
4	1 519 222 452	1 519 222 451	250	4,000		36.6	75.5	66.6	2
4.5	1 519 222 454	1 519 222 453	250	4,000		37.6	77.4	68.5	2
5	1 519 222 456	1 519 222 455	250	4,000		38.6	79.5	70.6	2
6.3	1 519 222 458	1 519 222 457	250	3,500		41.0	84.2	75.3	2
7.1	1 519 222 460	1 519 222 459	230	3,500		42.5	87.3	78.4	2

## Fittings

Gear pump flange, straight, for rectangular flange **20** see page 7

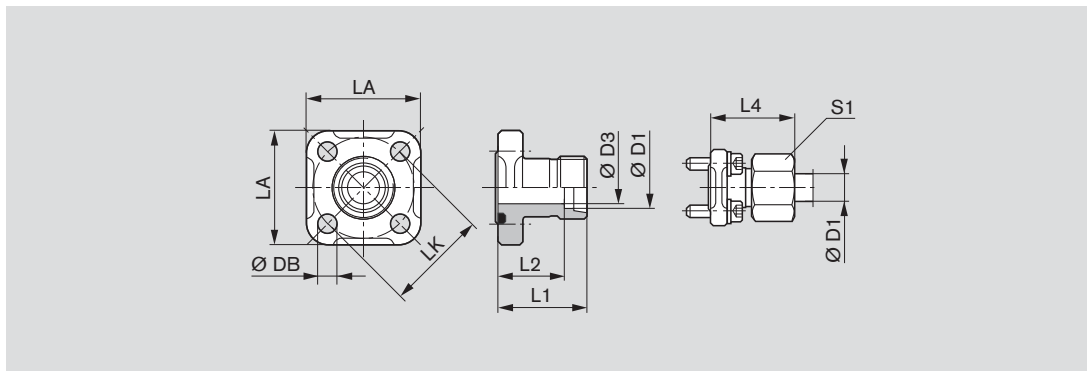

LK	D1	D3	L1	L2	L4	LA	S1	DB	Screws (metr.) 4 pieces	Seal ring	Mass kg	Part number	p (bar)
35	10L	8	30	23.0	39.0	40	19	6.4	M6x22	20x2.5	0.09	<b>1 515 702 064</b>	315
35	12L	10	30	23.0	39.0	40	22	6.4	M6x22	20x2.5	0.10	<b>1 515 702 065</b>	315
35	15L	12	30	23.0	38.0	40	27	6.4	M6x22	20x2.5	0.10	<b>1 515 702 066</b>	250

Complete fittings with seal ring, metric screw set, nuts and olive.

Gear pump flange, 90° angle, for rectangular flange **20** see page 7

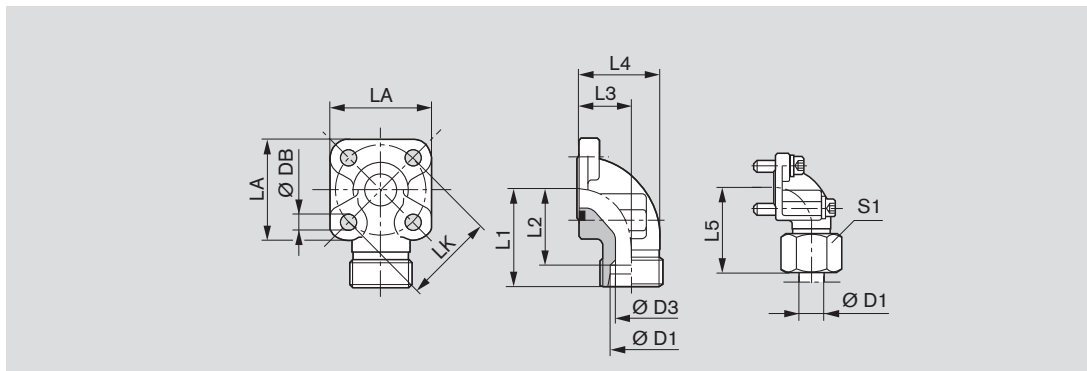

LK	D1	D3	L1	L2	L3	L4	L5	LA	S1	DB	Screws 2 pieces	Seal ring 2 pieces	Mass kg	Part number	p (bar)	
35	10L	8	38	31.0	16.5	26.5	47.0	40	19	6.4	M6x22	M6x35	20x2.5	0.16	<b>1 515 702 070</b>	315
35	12L	10	38	31.0	16.5	26.5	47.0	40	22	6.4	M6x22	M6x35	20x2.5	0.16	<b>1 515 702 071</b>	315
35	15L	12	38	31.0	16.5	26.5	46.0	40	27	6.4	M6x22	M6x35	20x2.5	0.15	<b>1 515 702 072</b>	250
35	16S	12	38	29.5	20.0	31.0	48.0	40	30	6.4	M6x22	M6x40	20x2.5	0.18	<b>1 515 702 002</b>	315
35	18L	15	38	29.5	20.0	31.0	47.0	40	32	6.4	M6x22	M6x40	20x2.5	0.18	<b>1 545 702 006</b>	250
35	20S	16	45	34.5	25.0	38.0	56.0	40	36	6.4	M6x22	M6x45	20x2.5	0.24	<b>1 515 702 017</b>	315

Complete fittings with seal ring, metric screw set, nuts and olive.

## Notes on commissioning and maintenance

### Filter recommendation

The major share of premature failures in external gear pumps is caused by contaminated hydraulic fluid.

Since a warranty cannot be issued for wear caused by dirt, we recommend filtration compliant with cleanliness level 20/18/15 ISO 4406, which reduces the degree of contamination to a permissible limit in terms of the size and concentration of dirt particles:

Operating pressure [bar]	>160	<160
Contamination class ISO 4406	18/15	19/16
To be reached with $\beta_x = 75$	20	25

We recommend that a full-flow filter always be used. Basic contamination of the hydraulic fluid used may not exceed class 20/18/15 according to ISO 4406. Experience has shown that new fluid quite often lies above this value. In such instances a filling device with special filter should be used.

### General

- The pumps supplied by us have been checked for function and performance. No modifications of any kind may be made to the pumps; any such changes will render the warranty null and void!
- Pump may only be operated in compliance with permitted data (see page 12).

### Project planning notes

Where external gear pumps are used we recommend that the following note be adhered to.

### Technical data

All stated technical data is dependent on production tolerances and is valid for specific marginal conditions.

Note that, as a consequence, variance is possible, and at certain marginal conditions (e.g. viscosity) **the technical data may change.**

### Characteristics

When designing the external gear pump, note the maximum possible service data based on the characteristics shown on pages 8 – 10.

Additional information on the proper handling of hydraulic products from Bosch Rexroth is available in our document: "General product information for hydraulic products" RE 07 008.

### Contained in delivery

The components with characteristics as described under ordering code and device measurements, pages 16 – 25, are contained in delivery.

### You can find further information in our publication:

**"General Operating Instructions for External Gear Units"**  
RE 07 012-B1.

## Spare parts

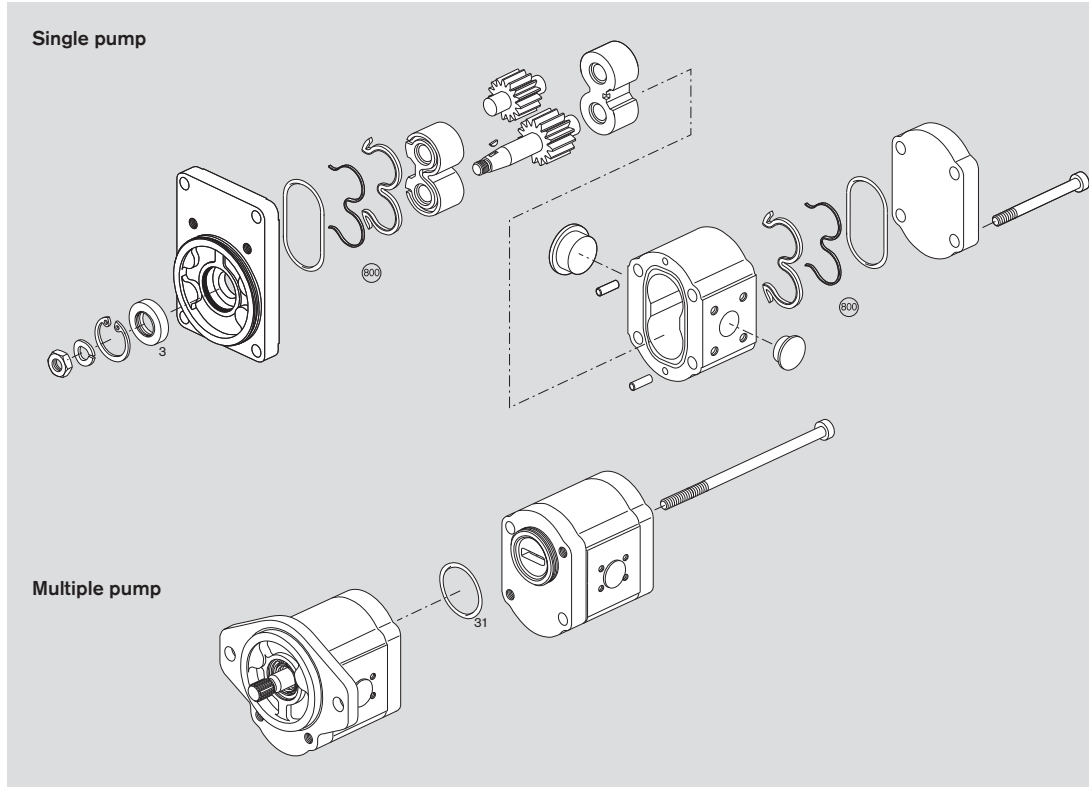

Page	Ordering code	Figure	Seal kit "B" Item 800 NBR	Shaft seal ring Item 3	Dimension	Material
16	AZPB - 32 - □□□□ H O 20 M B	A510160361	1517010248	1510283074	22 x 12 x 6	NBR
17	AZPB - 32 - □□□□ H O 01 M B	A510160343	1517010248	1510283074	22 x 12 x 6	NBR
18	AZPB - 32 - □□□□ C P 20 M B	A510B50044	1517010248	1510283074	22 x 12 x 6	NBR
19	AZPB - 32 - □□□□ C P 02 M B	A510B50026	1517010248	1510283074	22 x 12 x 6	NBR
20	AZPB - 32 - □□□□ C P 02 K B	A510B50007	1517010248	1510283071	22 x 12 x 6	FKM
21	AZPB - 32 - □□□□ N M 20 M B	A510B52026	1517010248	-	-	-
22	AZPB - 32 - □□□□ N M 02 M B	A510B32070	1517010248	-	-	-
23	AZPB - 32 - □□□□ N M 01 M B	A510B52007	1517010248	-	-	-
24	AZPB - 32 - □□□□ N Y 20 M B	A510B52042	1517010248	-	-	-
25	AZPB - 32 - □□□□ N Y 02 M B	A510B32088	1517010248	-	-	-

NBR = Perbunan®

FKM = Viton®

For multiple pumps

Seal ring Item 31 NBR	1 900 210 127
-----------------------------	---------------

## The AZ configurator at [www.boschrexroth.com/azconfigurator](http://www.boschrexroth.com/azconfigurator)

The AZ configurator assists you to easily configure your individual external gear unit. You only need to specify your requirements: from the displacement, direction of rotation, drive shaft, connection flange right up to the required rear cover. You immediately receive a project drawing (PDF format) if a configuration already exists. You receive the price of the configured external gear unit upon request.



The AZ configurator assists you to easily configure your individual external gear unit – all data needed for project planning are acquired through menu guidance.



Selection is made either by an ordering code or your technical requirements. This means that you can search for external gear units that have already been configured, or you can specify the configuration variant of the external gear unit based upon the operating parameters you require.



If the external gear unit you selected has been released you will receive the part number, ordering code and a detailed installation drawing. If your special configuration is not available please send your specification to Rexroth. One of our employees will then contact you.

## Ordering-No.

Ordering-No.	Page	Ordering-No.	Page	Ordering-No.	Page
0 510 010 008	20	0 510 114 021	22	0 510 120 319	17
0 510 010 009	22	0 510 114 022	22	0 510 120 320	17
0 510 010 010	19	0 510 114 023	22	0 510 120 321	17
0 510 010 011	23	0 510 114 024	23	0 510 120 322	17
0 510 010 313	20	0 510 114 025	19	0 510 120 323	17
0 510 010 314	22	0 510 114 026	19	0 510 120 324	17
0 510 010 315	19	0 510 114 027	19	0 510 120 325	17
0 510 010 316	23	0 510 114 028	23	0 510 120 326	16
0 510 020 003	17	0 510 114 029	23	0 510 120 327	16
0 510 020 303	17	0 510 114 030	18	0 510 120 328	16
0 510 110 017	20	0 510 114 031	18	0 510 120 329	16
0 510 110 018	20	0 510 114 032	18	0 510 120 330	16
0 510 110 019	22	0 510 114 033	21	0 510 120 331	16
0 510 110 020	22	0 510 114 034	21	0 510 120 332	16
0 510 110 021	23	0 510 114 035	21	0 510 120 333	16
0 510 110 022	19	0 510 114 324	20	0 510 122 012	20
0 510 110 023	19	0 510 114 325	20	0 510 122 013	20
0 510 110 024	23	0 510 114 326	20	0 510 122 014	22
0 510 110 025	18	0 510 114 327	22	0 510 122 015	22
0 510 110 026	18	0 510 114 328	22	0 510 122 016	19
0 510 110 027	21	0 510 114 329	22	0 510 122 017	19
0 510 110 028	21	0 510 114 330	19	0 510 122 018	23
0 510 110 324	20	0 510 114 331	19	0 510 122 019	23
0 510 110 325	20	0 510 114 332	19	0 510 122 020	18
0 510 110 326	22	0 510 114 333	23	0 510 122 021	18
0 510 110 327	22	0 510 114 334	23	0 510 122 022	21
0 510 110 328	19	0 510 114 335	23	0 510 122 023	21
0 510 110 329	19	0 510 114 336	18	0 510 122 316	20
0 510 110 330	23	0 510 114 337	18	0 510 122 317	20
0 510 110 331	23	0 510 114 338	18	0 510 122 318	22
0 510 110 332	18	0 510 114 339	21	0 510 122 319	22
0 510 110 333	18	0 510 114 340	21	0 510 122 320	19
0 510 110 334	21	0 510 114 341	21	0 510 122 321	19
0 510 110 335	21	0 510 120 020	17	0 510 122 322	23
0 510 112 014	20	0 510 120 021	17	0 510 122 323	23
0 510 112 015	20	0 510 120 022	17	0 510 122 324	18
0 510 112 016	22	0 510 120 023	17	0 510 122 325	18
0 510 112 017	23	0 510 120 024	17	0 510 122 326	21
0 510 112 018	19	0 510 120 025	17	0 510 122 327	21
0 510 112 019	18	0 510 120 026	17	1 519 222 443	25
0 510 112 020	21	0 510 120 027	17	1 519 222 444	25
0 510 112 321	20	0 510 120 028	16	1 519 222 445	25
0 510 112 322	22	0 510 120 029	16	1 519 222 446	25
0 510 112 323	19	0 510 120 030	16	1 519 222 447	25
0 510 112 324	23	0 510 120 031	16	1 519 222 448	25
0 510 112 325	18	0 510 120 032	16	1 519 222 449	25
0 510 112 326	21	0 510 120 033	16	1 519 222 450	25
0 510 114 018	20	0 510 120 034	16	1 519 222 451	25
0 510 114 019	20	0 510 120 035	16	1 519 222 452	25
0 510 114 020	20	0 510 120 318	17	1 519 222 453	25

## Ordering-No.

Ordering-No.	Page	Ordering-No.	Page	Ordering-No.	Page
1 519 222 454	25	1 519 222 469	24	1 519 222 477	24
1 519 222 455	25	1 519 222 470	24	1 519 222 478	24
1 519 222 456	25	1 519 222 471	24	1 519 222 479	24
1 519 222 457	25	1 519 222 472	24	1 519 222 480	24
1 519 222 458	25	1 519 222 473	24	1 519 222 481	24
1 519 222 459	25	1 519 222 474	24	1 519 222 482	24
1 519 222 460	25	1 519 222 475	24	1 519 222 483	24
1 519 222 468	24	1 519 222 476	24		

## Notes

© This document, as well as the data, specifications and other information set forth in it, are the exclusive property of Bosch Rexroth AG. It may not be reproduced or given to third parties without its consent.  
The data specified above only serve to describe the product. No statements concerning a certain condition or suitability for a certain application can be derived from our information. The information given does not release the user from the obligation of own judgment and verification. It must be remembered that our products are subject to a natural process of wear and aging.