

Electric Drives
and Controls

Hydraulics

Linear Motion and
Assembly Technologies

Pneumatics

Service

Rexroth
Bosch Group

1/24

4/2 and 4/3 directional valves, internally pilot operated, externally pilot operated

RE 24751-XE-B2/09.13
Replaces: 01.10

Type H-4WEH...XE...

Sizes 10, 16, 25, 32
Component series 4X, 6X, 7X
Maximum operating pressure 350 bar
Maximum flow 1100 l/min

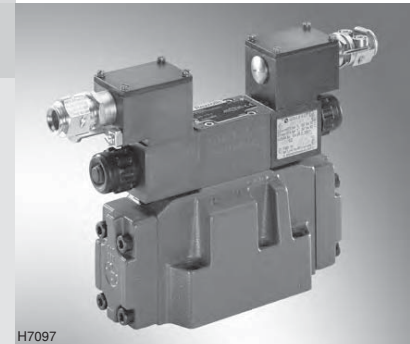

H7097

Actual product may differ

ATEX units
For explosive areas

Part II Data sheet



Information on the explosion protection:

- Area of application in accordance with the Explosion Protection Directive 94/9/EC: **II 2G**
- Type of protection of the valve solenoid: Ex e mb IIC T4 Gb according to EN 60079-7:2007 / EN 60079-18:2009

Special features of seawater-resistant valves

- The external metal parts are galvanized or treated with an anti-corrosion agent.
- The conditional seawater-resistance is defined by "SO329" in the ordering code.

What you need to know about these operating instructions

These operating instructions apply to the explosion-proof version of Rexroth valves and consist of the following three parts:

- Part I General information 07010-X-B1
- Part II Data sheet 24751-XE-B2
- Part III Product-specific instructions 24751-XE-B3

Operating instructions 24751-XE-B0

You can find further information on the correct handling of Rexroth hydraulic products in our publication "General product information on hydraulic products" 07008.

Table of contents

Contents	Page
Features	2
Function, section	3
Ordering code and scope of delivery	4
Control spool symbols	6
Pilot oil supply	9
Technical data	10
Electrical connection	13
Characteristic curves, performance limits	15
Switching time adjustment, pressure reducing valve, preload valve	19
Dimensions	20

Features

- Valve to control the start, stop and direction of a flow, for proper use in explosive areas
- Electro-hydraulic actuation (WEH)
- For subplate mounting, porting pattern according to DIN 24340-A and ISO 4401, subplates available in FE/ZN version (see pages 20 to 23)
- Spring centering, spring end position or hydraulic end position
- Wet-pin DC or AC solenoids
- Solenoid coil can be rotated by 90°
- Manual override, optional
- Electrical connection as individual connection with cable gland
- Switching time adjustment, optional
- Preload valve in channel P of the main valve, optional

Function, section

Type H-4WEH 16...XE...

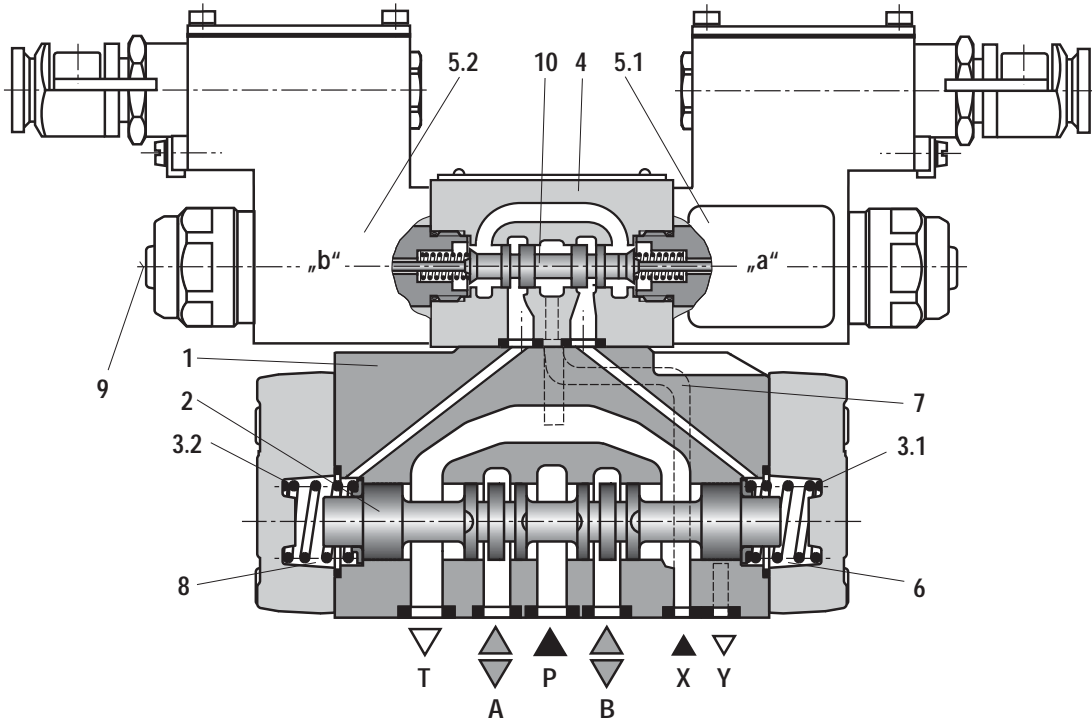

Directional valves type H-4WEH...

The valve type H-4WEH is a directional spool valve with electro-hydraulic actuation. It controls the start, stop and direction of a flow.

The directional valves basically consist of the main valve with housing (1), the main control spool (2), one or two return springs (3.1) and (3.2), as well as the pilot control valve (4) with one or two solenoids "a" (5.1) and/or "b" (5.2).

The main control spool (2) in the main valve is held in the zero or initial position by the springs or by means of pressurization. In the initial position, the two spring chambers (6) and (8) are connected with the tank in a depressurized form via the pilot control valve (4). The pilot control valve is supplied with pilot oil via the control line (7). Supply can be effected internally or externally (externally via port X).

Upon actuation of the pilot control valve, e.g. solenoid "a", the pilot control spool (10) is moved to the left and thus, the spring chamber (8) is pressurized with pilot pressure. The spring chamber (6) remains depressurized.

The pilot pressure acts on the left side of the main control spool (2) and moves it against the spring (3.1). This connects ports P with B and A with T in the main valve.

When the solenoid is switched off, the pilot control spool returns into the initial position (except for impulse spool). The spring chamber (8) is unloaded to the tank.

The pilot oil from the spring chamber is displaced into channel Y via the pilot control valve.

The pilot oil supply and return can be effected internally or externally.

The manual override (9) allows control spool (10) to be moved without solenoid energization.

Ordering code and scope of delivery

	H	4	WEH			/	6E			XE
Up to 350 bar	= H									
4-way version		= 4								
Directional valve, electro-hydraulically actuated			= WEH							
Size										
Size 10										= 10
Size 16										= 16
Size 25										= 25
Size 32										= 32
Control spool return main valve										
By means of springs										= no code
Hydraulically ¹⁾										= H
For control spool symbols, see page 6										
Component series 40 to 49 – size 10 (40 to 49: Unchanged installation and connection dimensions)										= 4X
Component series 60 to 69 – size 25 (4W.H 25.) and size 32 (60 to 69: Unchanged installation and connection dimensions)										= 6X
Component series 70 to 79 – size 16 (70 to 79: Unchanged installation and connection dimensions)										= 7X
Control spool return in the pilot control valve with 2 spool positions and 2 solenoids only possible with control spool C, D, K, Z and hydraulic control spool return in the main valve:										
Without spring return										= O
Without spring return with detent										= OF
Pilot control valve with wet-pin solenoids										
High-power valve (RE 23178-XE-B2)										= 6E
Direct voltage 24 V										= G24
AC voltage 230, V 50/60 Hz										= W230R
For further ordering codes for other voltages, see page 14										
Without manual override										= no code
With manual override (standard)										= N
Explosion protection "increased safety" For details see information on the explosion protection, page 11										= XE
Pilot oil supply external, pilot oil return external ²⁾										= no code
Pilot oil supply internal, pilot oil return external ³⁾										= E
Pilot oil supply internal, pilot oil return internal ³⁾										= ET
Pilot oil supply external, pilot oil return internal ²⁾										= T

Included in the scope of delivery:

Valve operating instructions with declaration of conformity in Part III

Explanation of the footnotes, see page 5

Control spool symbols

2 spool positions

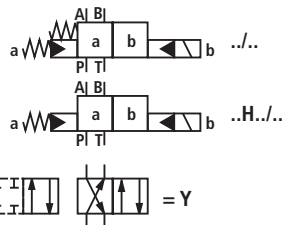
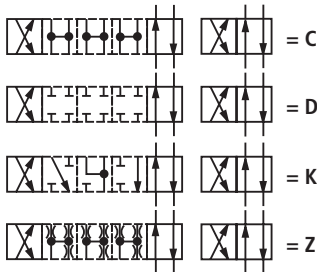
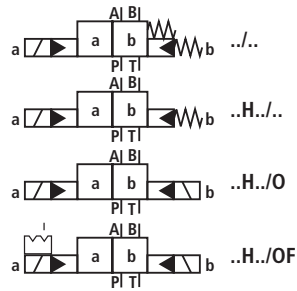

3 spool positions

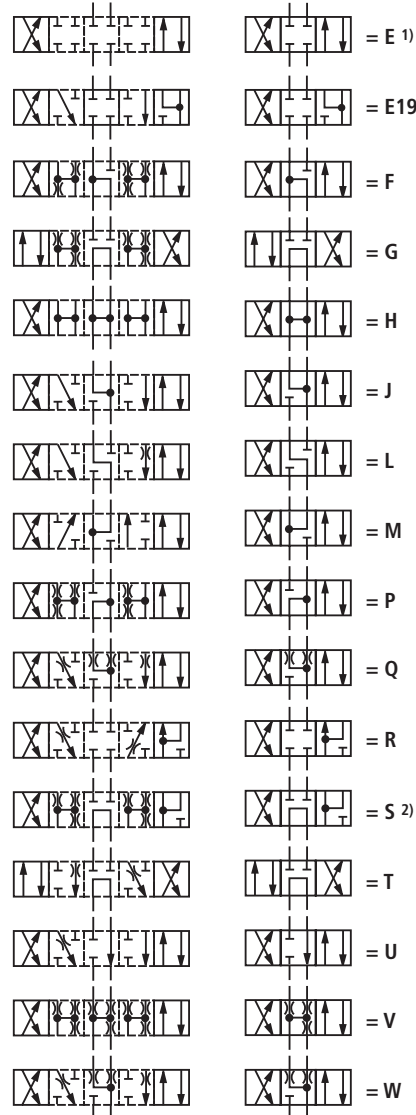
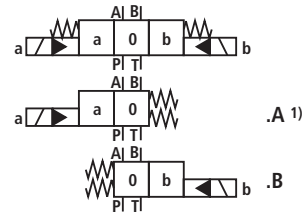

1) Example: Control spool E with spool position "a"
Order example:
H-4WEH 16 EA7X/6EG24N9XEETSZ2B10..V..

2) Control spool S only for size 16

Other control spool variants upon request

Control spool symbols for valves with 2 spool positions

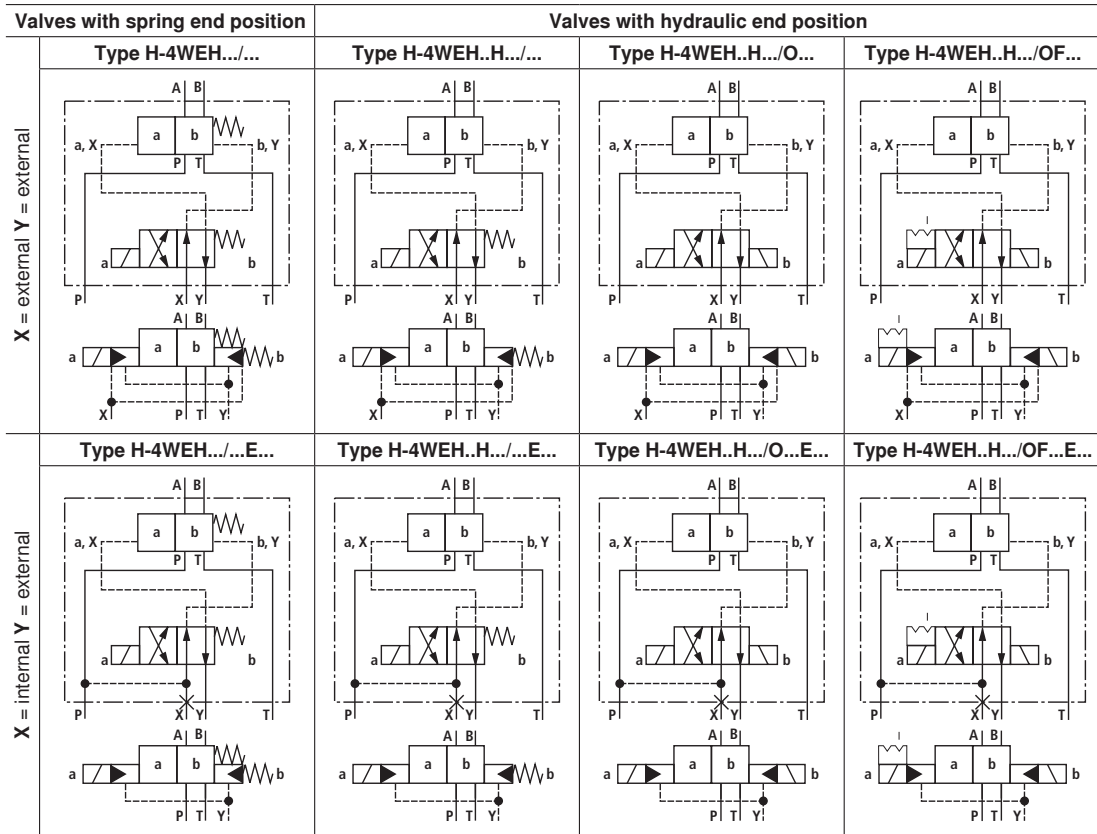

Continued on the next page

Control spool symbols for valves with 2 spool positions

Continuation from previous page

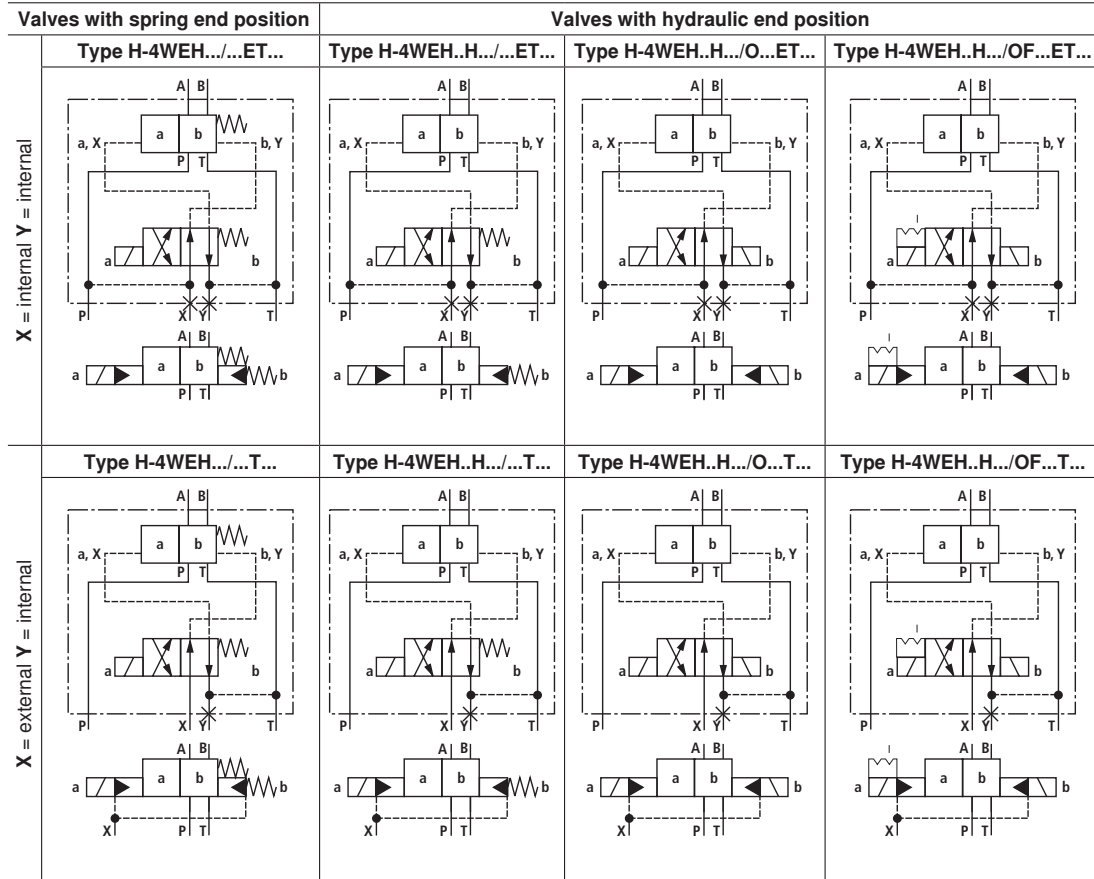

Control spool symbols for valves with 3 spool positions

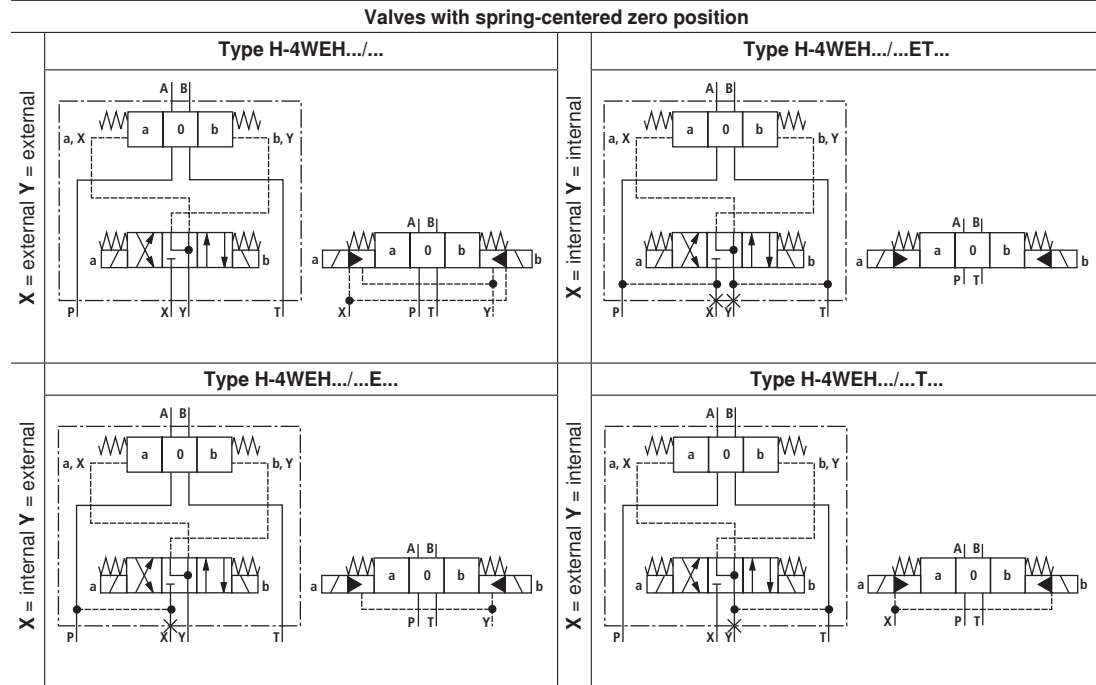

Pilot oil supply

Type H-4WEH...

The pilot oil supply is effected **externally** via the X channel from a separate circuit.

The pilot oil return is effected **externally** via the Y channel into the tank.

Type H-4WEH...E...

The pilot oil supply is effected **internally** from the P channel of the main valve.

The pilot oil return is effected **externally** via the Y channel into the tank. In the subplate, port X is closed.

Type H-4WEH...ET...

The pilot oil supply is effected **internally** from the P channel of the main valve.

The pilot oil return is effected **internally** via the T channel into the tank. In the subplate, ports X and Y are closed.

Type H-4WEH...T...

The pilot oil supply is effected **externally** via the X channel from a separate circuit.

The pilot oil return is effected **internally** via the T channel into the tank. In the subplate, port Y is closed.

Throttle insert

Use of the throttle insert (2) is necessary if the pilot oil supply in the P channel of the pilot control valve (1) is to be limited.

The throttle insert (2) is inserted in channel P of the pilot control valve (1).

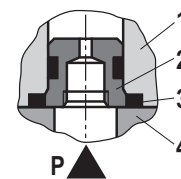

- 1 Pilot control valve
- 2 Throttle insert
- 3 Seal ring
- 4 Main valve

Technical data

general

Installation position	Any; horizontal with valves with hydraulic control spool return "H" and control spool C, D, K, Z or Y					
Ambient temperature range	°C	-20 ... +70 ¹⁾				
Storage temperature range	°C	-20 ... +50				
Sizes	Size	10	16	25	32	
Weight	Valve with one solenoid	kg	8.5	11	19	36.5
	Valve with two solenoids, spring-centered	kg	10.2	12.5	20.5	39
	Switching time adjustment	kg	0.8			
	Pressure reducing valve	kg	0.4			
Surface protection	Valve body	Pilot control valve	Galvanized coating			
		Main valve	Standard: Painting, layer thickness max. 100 µm SO329: Galvanically coated, Zn and passivated			
	Solenoid		Galvanized coating			

hydraulic

Sizes	Size	10	16	25	32	
Maximum operating pressure						
Ports P, A, B	bar	350				
Port T	With pilot oil return Y external	bar	250			
	With pilot oil return Y internal	bar	210			
Port Y	With pilot oil return external	bar	210			
Flow of the main valve	l/min	Up to 160	Up to 300	Up to 650	Up to 1100	
Maximum pilot pressure	bar	250 (with a higher pilot pressure, use of a pressure reducing valve is required)				
Minimum pilot pressure						
– With pilot oil supply X external or internal (control spool D, K, E, E19, J, L, M, Q, R, U, W)						
	3-spool position valve, spring-centered	bar	10	14	13	8.5
	2-spool position valve, spring end position	bar	10	14	13	10
	2-spool position valve, hydraulic end position	bar	7	14	8	5
– With internal pilot oil supply (control spool C, F, H, P, T, V, Z, S ²⁾)						
		bar	6.5 ³⁾	4.5 ⁴⁾	4.5 ⁴⁾	4.5 ⁴⁾
Pilot volume for switching process						
	3-spool position valve, spring-centered	cm ³	2.04	5.72	14.2	29.4
	2-spool position valve	cm ³	4.08	11.45	28.4	58.8
Pilot volume for shortest switching time	l/min	Approx. 35	Approx. 35	Approx. 35	Approx. 45	
Hydraulic fluid	Mineral oil (HL, HLP) according to DIN 51524 ⁵⁾ , fast biodegradable hydraulic fluids according to VDMA 24568 (see also RE 90221), HETG (rape seed oil) ⁵⁾ , HEPG (polyglycols) ⁶⁾ , HEES (synthetic esters) ⁶⁾ , flame-resistant hydraulic fluid HFC according to ISO 12922 ⁷⁾ , other hydraulic fluids on request Ignition temperature > 180 °C					
Hydraulic fluid temperature range	°C	-20 ... +80 (NBR seals) -15 ... +80 (FKM seals)				
Viscosity range	mm ² /s	2.8 ... 500				
Maximum admissible degree of contamination of the hydraulic fluid, cleanliness class according to ISO 4406 (c)		Class 20/18/15 ⁸⁾				

Footnotes, see page 11

Technical data

electric

Voltage type		Direct voltage	Alternating voltage
Available voltages	V	24, 48, 96, 110	110, 230
Voltage tolerance (nominal voltage)	%	±10	
Admissible residual ripple	%	< 5	-
Duty cycle/operating mode according to VDE 0580		S1 (continuous operation)	
Switching time according to ISO 6403		see page 12	
Switching frequency	1/h	Up to 15000	Up to 7200
Nominal power at ambient temperature 20 °C	W	17	
Maximum power with 1.1 x nominal voltage and ambient temperature 20 °C	W	20.6	
Protection class according to EN 60529		IP 66 ⁹⁾	

Important:

Solenoids for AC voltage are DC solenoids with integrated rectifier

Information on the explosion protection

Area of application in accordance with the Explosion Protection Directive 94/9/EC	II 2G
Type of protection Valve	c (EN 13463-5:2011)
Maximum surface temperature ¹⁰⁾	135 °C
Temperature class	T4
Type of protection Valve solenoid according to EN 60079-7:2007 / EN 60079-18:2009	Ex e mb IIC T4 Gb
Type examination certificate Solenoid	KEMA 02ATEX2240 X
"IECEx Certificate of Conformity" Solenoid	IECEx DEK 12.0068X
Ambient temperature range	°C -20 ... +70 ¹⁾
Special conditions for safe use	<ul style="list-style-type: none"> - In case of valves with two solenoids, maximally one of the solenoids may be energized at a time. - Simultaneously energizing several valves in bank assembly is possible if the ambient temperature does not exceed 60 °C. - In case of bank assembly, if only one of the solenoids is energized at a time, and during individual operation, the maximum ambient temperature may not exceed 70 °C. - The maximum temperature of the valve casing surface is 120 °C. This has to be considered when selecting the connection cable and contact of the connection cable with the casing surface is to be prevented.

¹⁾ Observe the "Special conditions for safe use" on page 11.

²⁾ Control spool S only for size 16

³⁾ For control spools C, F, G, H, P, T, V, Z, an internal pilot oil supply without preload valve is only possible if the flow from P → T in the central position (for 3-spool position valve) or while crossing the central position (for 2-spool position valve) is so large that the pressure differential of P → T reaches a value of at least 6.5 bar.

⁴⁾ For control spools C, F, G, H, P, T, V, Z, S ¹⁾ – by means of preload valve (not size 10) or correspondingly high flow.

⁴⁾ Suitable for NBR **and** FKM seals

⁵⁾ Suitable **only** for FKM seals

⁷⁾ Only in connection with NBR seals, max. admissible pressure 210 bar, $\Delta p < 15$ bar, hydraulic fluid temperature max. 60 °C

More information is available from our sales staff.

⁸⁾ The cleanliness classes specified for the components must be adhered to in hydraulic systems. Effective filtration prevents faults and at the same time increases the life cycle of the components.

For the selection of the filters see www.boschrexroth.com/filter.

⁹⁾ With correctly installed electrical connection

¹⁰⁾ Surface temperature > 50 °C, provide contact protection

Technical data

Switching times (= contacting at the pilot control valve until start of opening of the control edge in the main valve and change in the control spool stroke by 95 %)

Pilot pressure		bar	70	250	Spring
			ON		OFF
Size 10	without throttle insert	ms	50 ... 70	50 ... 70	30 ... 40
	with throttle insert	ms	70 ... 100	60 ... 80	30 ... 40
Size 16	without throttle insert	ms	60 ... 90	50 ... 70	60 ... 90
	with throttle insert	ms	120 ... 140	90 ... 110	60 ... 90
Size 25	without throttle insert	ms	80 ... 110	60 ... 80	110 ... 140
	with throttle insert	ms	210 ... 260	130 ... 160	110 ... 140
Size 32	without throttle insert	ms	90 ... 140	80 ... 110	150 ... 170
	with throttle insert	ms	430 ... 570	240 ... 360	150 ... 170

Important:

- The switching times are measured according to ISO 6403 with HLP46, $\hat{t}_{oil} = 40 \text{ °C} \pm 5 \text{ °C}$. With different oil temperatures, deviations are possible.
- The switching times increase by approx. 30 ms if the pressure reducing valve "D3" is used.
- The switching times have been determined under ideal conditions and may differ in the system, depending on the application conditions.

Free flow cross-sections in zero position with control spools Q, V and W

Control spool Q	A - T, B - T	mm ²	13	32	78	83	78
Control spool V	A - T, B - T	mm ²	13	32	73	83	73
	P - A, P - B	mm ²	13	32	84	83	84
Control spool W	A - T, B - T	mm ²	2.4	6	10	14	20

Electrical connection

The type-examination tested valve solenoid of the valve is equipped with a terminal box and a type-tested cable gland.

The connection is polarity-independent.
Solenoids to be connected to AC voltage are equipped with an integrated rectifier.

Important

When establishing the electrical connection, the protective earthing conductor (PE \perp) has to be connected properly.

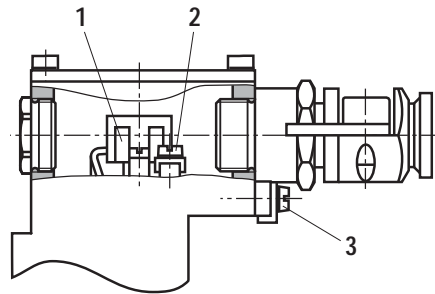

Properties of the connection terminals

Position	Function	Connectable line cross-section
1	Operating voltage connection	Single-wire 0.75 ... 2.5 mm ² Finely stranded 0.75 ... 1.5 mm ²
2	Connection for protective earthing conductor	Single-wire max. 2.5 mm ² Finely stranded max. 1.5 mm ²
3	Connection for potential equalization conductor	Single-wire 4 ... 6 mm ² Finely stranded 4 mm ²

Cable gland

Type approval	II 2G Ex e IIC Gb
Threaded connection	M20 x 1.5
Protection class according to EN 60529	IP66 ¹⁾
Line diameter	mm 9 ... 11
Sealing	Outer sheath sealing

Connection line

Line type	Non-armored cables and lines (outer sheath sealing)
Temperature range	°C -30 ... > +110

¹⁾ If installed properly

Electrical connection

Circuit diagrams

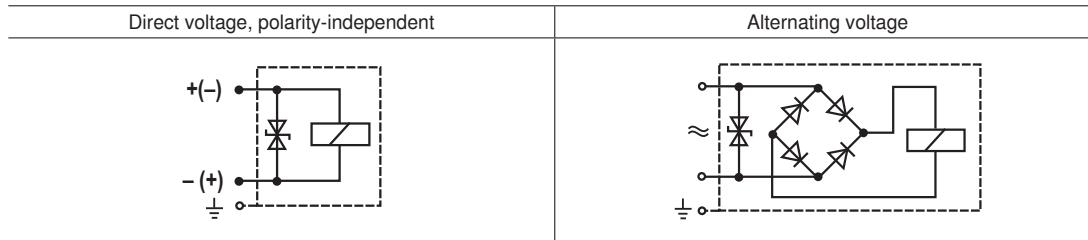

Over-current fuse and switch-off voltage peaks

Important

Corresponding to the rated current, a fuse according to DIN 41571 and EN / IEC 60127 has to be connected ahead of every valve solenoid (max. $3 \times I_{rated}$).

The shut-off threshold of the fuse has to match the prospective short-circuit current of the supply source.

The prospective short-circuit current of the supply source may amount to a maximum of 1500 A.

This fuse may only be installed outside the explosive area or must be of an explosion-proof design.

When inductivities are switched off, voltage peaks are the result which may cause faults in the connected control electronics. For this reason, the valve solenoids comprise an interference protection circuit which dampens this voltage peak to the voltage value shown in the table.

Voltage data in the valve type code	Nominal voltage valve solenoid	Rated current valve solenoid	Rated current external miniature fuse: Medium time-lag (M) according to DIN 41571 and EN/IEC 60127	Rated voltage of external miniature fuse: Medium time-lag (M) according to DIN 41571 and EN/IEC 60127	Maximum voltage value upon switch-off	Interference protection circuit
G24	24 V DC	0.708 A DC	800 mA	250 V	-90 V	Suppressor diode bi-directional
G48	48 V DC	0.354 A DC	400 mA	250 V	-200 V	
G96	96 V DC	0.177 A DC	200 mA	250 V	-370 V	
G110	110 V DC	0.155 A DC	200 mA	250 V	-390 V	
W110R	110 V AC	0.163 A AC	200 mA	250 V	-3 V	Bridge rectifier and suppressor diode
W230R	230 V AC	0.078 A AC	80 mA	250 V	-3 V	

Characteristic curves: Type H-4WEH 10... (measured with HLP46, $\dot{\vartheta}_{oil} = 40 \text{ }^\circ\text{C} \pm 5 \text{ }^\circ\text{C}$)

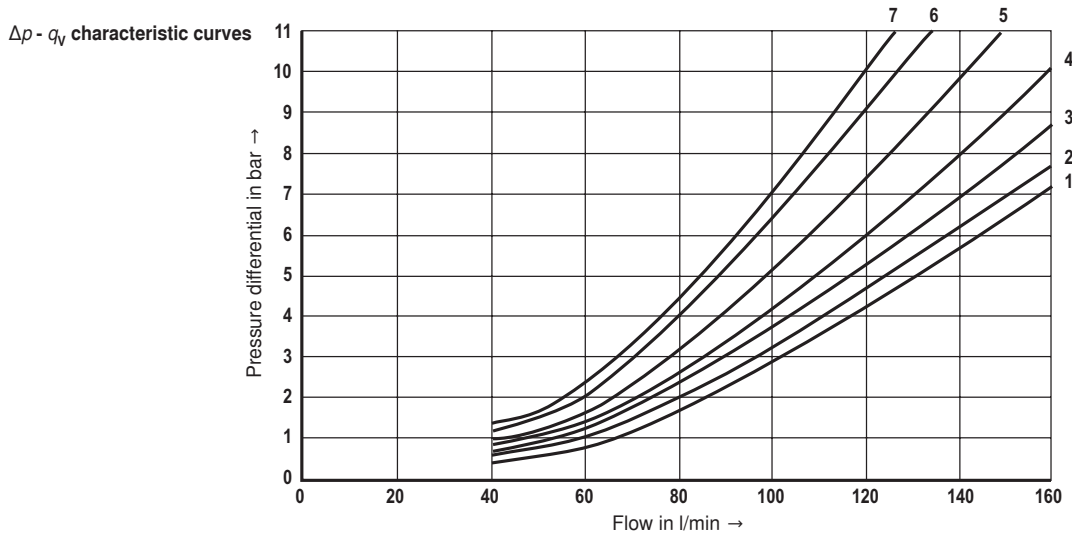

Characteristic curve selection

Control spool	Spool position				Control spool	Zero position		
	P - A	P - B	A - T	B - T		A - T	B - T	P - T
E, Y, D	2	2	4	5				
F	1	4	1	4	F	3	-	6
G, T	4	2	2	6	G, T	-	-	7
H, C	4	4	1	4	H	1	3	5
J, K	1	2	1	3				
L	2	3	1	4	L	3	-	-
M	4	4	3	4				
P	4	1	3	4	P	-	7	5
Q, V, W, Z	2	2	3	5				
R	2	2	3	-				
U	3	3	3	4	U	-	4	-

Performance limits: Type H-4WEH 10... (measured with HLP46, $\dot{\vartheta}_{oil} = 40 \text{ }^\circ\text{C} \pm 5 \text{ }^\circ\text{C}$)

2- and 3-spool position valves

Maximum flow q_v in l/min

Control spool	Operating pressure p_{max} in bar		
	200	250	315
E, J, L, M, Q, R, U, V, W, C, D, K, Z, Y	160	160	160
H	160	150	120
G, T	160	160	140
F, P	160	140	120

Important

The specified switching power limits are valid for operation with two directions of flow (e.g. from P → A and simultaneous return flow from B → T) in the ratio 1:1.

Due to the flow forces acting within the valves, the admissible switching power limit may be considerably lower with only one direction of flow (e.g. from P → A while port B is blocked or if there are simultaneous flows in different directions).

(In such cases, please consult us.)

The switching power limit was established while the solenoids were at operating temperature, at 10 % undervoltage and without tank preloading.

Characteristic curves: Type H-4WEH 16... (measured with HLP46, $\dot{v}_{oil} = 40 \text{ }^\circ\text{C} \pm 5 \text{ }^\circ\text{C}$)

$\Delta p - q_v$ characteristic curves

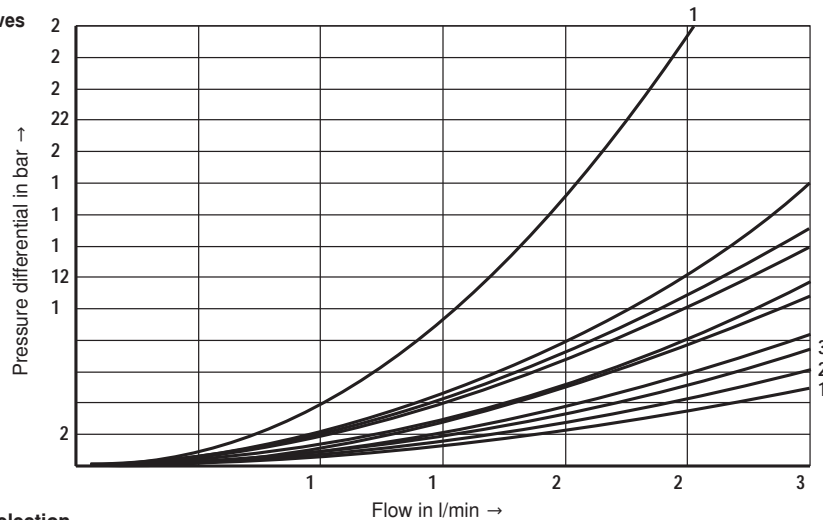

Characteristic curve selection

Control spool	Spool position				
	P-A	P-B	A-T	B-T	P-T
E, Y, D	1	1	3	4	-
E19	-	6	8	7	-
F	1	1	5	4	-
G, T	4	1	5	5	9
H, C, Q, V, Z	1	1	5	6	-
J, K, L	1	1	5	6	-

Control spool	Spool position				
	P-A	P-B	A-T	B-T	P-T
M, W	1	1	3	4	-
R	1	1	3	-	-
U	2	2	3	5	-
S	3	3	3	-	10

Performance limits: Type H-4WEH 16... (measured with HLP46, $\dot{v}_{oil} = 40 \text{ }^\circ\text{C} \pm 5 \text{ }^\circ\text{C}$)

2-spool position valve
Maximum flows q_v in l/min

Control spool	Operating pressure p_{max} in bar				
	70	140	210	280	350
X external, spring end position in the main valve (with $p_{St min} = 12 \text{ bar}$)					
C, D, K, Y, Z	300	300	300	300	300
X external, spring end position in the main valve ¹⁾					
C	300	300	300	300	300
D, Y	300	270	260	250	230
K	300	250	240	230	210
Z	300	260	190	180	160
X external, hydraulic end position in the main valve					
HC, HD, HK, HZ, HY	300	300	300	300	300

3-spool position valve
Maximum flows q_v in l/min

Control spool	Operating pressure p_{max} in bar				
	70	140	210	280	350
X external, spring centering in the main valve					
E, E19, H, J, L, M, Q, U, W, R	300	300	300	300	300
F, P	300	250	180	170	150
G, T	300	300	240	210	190
S	300	300	300	250	220
V	300	250	210	200	180

Important

See also "Important" page 15

Important

¹⁾ If the specified flow values are exceeded, the function of the return spring is no longer guaranteed if the pilot pressure fails.

- With pilot oil supply **X internal**, you must always use a preload valve due to the negative overlap of the control spools F, G, H, P, T, S, C and HC.
- With control spools V, Z and HZ, the preload valve is **not** required for flows > 180 l/min.

Characteristic curves: Type H-4WEH 25... (measured with HLP46, $\vartheta_{oil} = 40 \text{ }^\circ\text{C} \pm 5 \text{ }^\circ\text{C}$)

$\Delta p - q_v$ characteristic curves

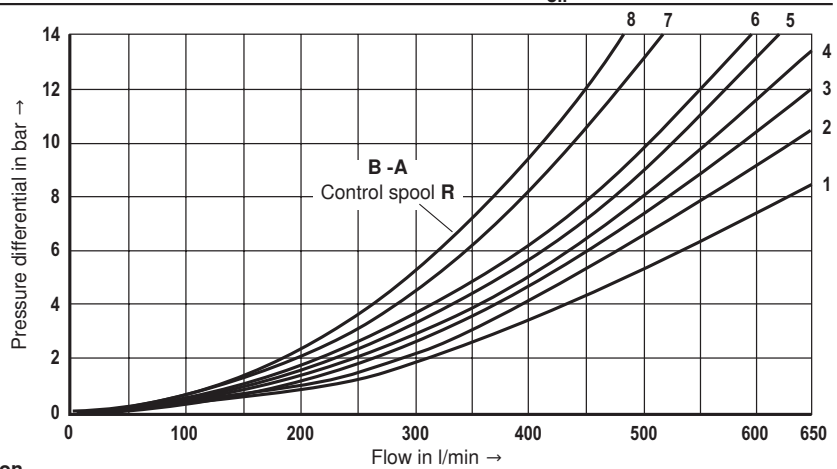

- 7 Control spool **G**
central position **P - T**
- 8 Control spool **T**
central position **P - T**

Characteristic curve selection

Control spool	Spool position				Control spool	Spool position				Control spool	Spool position			
	P - A	P - B	A - T	B - T		P - A	P - B	A - T	B - T		P - A	P - B	A - T	B - T
E	1	1	1	3	L	2	2	3	3	U	4	1	1	6
F	1	4	3	3	M	4	4	1	4	V	2	4	3	6
G	3	1	2	4	P	4	1	1	5	W	1	1	1	3
H	4	4	3	4	R	2	1	1	-	T	3	1	2	4
J, Q	2	2	3	5										

Performance limits: Type H-4WEH 25... (measured with HLP46, $\vartheta_{oil} = 40 \text{ }^\circ\text{C} \pm 5 \text{ }^\circ\text{C}$)

2-spool position valve

Maximum flows q_v in l/min

Control spool	Operating pressure p_{max} in bar				
	70	140	210	280	350
X external, spring end position in the main valve (with $p_{St, min} = 13 \text{ bar}$)					
C, D, K, Y, Z	700	700	700	700	650

X external, spring end position in the main valve ¹⁾

C	700	700	700	700	650
D, Y	700	650	400	350	300
K	700	650	420	370	320
Z	700	700	650	480	400

X external, hydraulic end position in the main valve

HC, HD, HK, HZ, HY	700	700	700	700	700
HC../O..					
HD../O..					
HK../O..	700	700	700	700	700
HZ../O..					
HC../OF..					
HD../OF..					
HK../OF..	700	700	700	700	700
HZ../OF..					

Important

See also "Important" page 15

3-spool position valve

Maximum flows q_v in l/min

Control spool	Operating pressure p_{max} in bar				
	70	140	210	280	350
X external, spring centering in the main valve					
E, L, M, Q, U, W,	700	700	700	700	650
G, T	400	400	400	400	400
F	650	550	430	330	300
H	700	650	550	400	360
J	700	700	650	600	520
P	650	550	430	330	300
V	650	550	400	350	310
R	700	700	700	650	580

X external, spring centering in the main valve

Important

¹⁾ If the specified flow values are exceeded, the function of the return spring is no longer guaranteed if the pilot pressure fails.

- With pilot oil supply **X internal**, a preload valve has to be used for flows < 180 l/min due to the negative overlap of the control spools Z, HZ and V.
- With pilot oil supply **X internal**, you must always use a preload valve due to the negative overlap of the control spools C, HC, F, G, H, P and T.

Characteristic curves: Type H-4WEH 32... (measured with HLP46, $\vartheta_{oil} = 40 \text{ }^\circ\text{C} \pm 5 \text{ }^\circ\text{C}$)

$\Delta p - q_v$ characteristic curves – control spools E, R and W

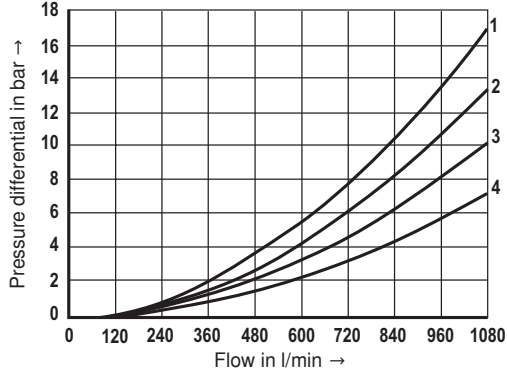

$\Delta p - q_v$ characteristic curves – control spools G and T

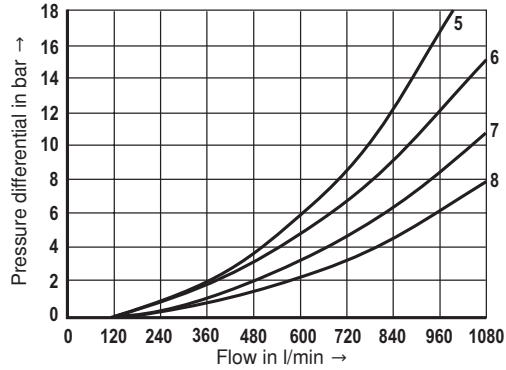

$\Delta p - q_v$ characteristic curves – all remaining control spools

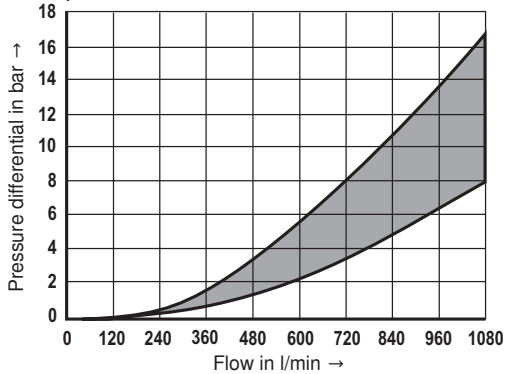

Control spool	Spool position				
	P-A	P-B	A-T	B-T	B-A
E	4	4	3	2	-
R	4	4	3	-	1
W	4	4	3	2	-

Control spool	Spool position				
	P-A	P-B	A-T	B-T	P-T
G	7	8	7	5	6
T	7	8	7	5	6

Performance limits: Type H-4WEH 32... (measured with HLP46, $\vartheta_{oil} = 40 \text{ }^\circ\text{C} \pm 5 \text{ }^\circ\text{C}$)

2-spool position valve

Maximum flows q_v in l/min

Control spool	Operating pressure p_{max} in bar				
	70	140	210	280	350
X external, spring end position in the main valve (with $p_{St min} = 10 \text{ bar}$)					
C, D, K, Y, Z	1100	1040	860	750	680

X external, spring end position in the main valve ¹⁾

C	1100	1040	860	800	700
D, Y	1100	1040	540	480	420
K	1100	1040	860	500	450
Z	1100	1040	860	700	650

X external, hydraulic end position in the main valve

HC, HD, HK, HZ, HY	1100	1040	860	750	680
--------------------	------	------	-----	-----	-----

Important

See also "Important" page 15

3-spool position valve

Maximum flows q_v in l/min

Control spool	Operating pressure p_{max} in bar				
	70	140	210	280	350
X external, spring centering in the main valve					
E, J, L, M, Q, U, W, R	1100	1040	860	750	680
G, T, H, F, P	900	900	800	650	450
V	1100	1000	680	500	450

Important

¹⁾ If the specified flow values are exceeded, the function of the return spring is no longer guaranteed if the pilot pressure fails.

- With pilot oil supply **X internal**, a preload valve has to be used for flows < 180 l/min due to the negative overlap of the control spools Z, HZ and V.
- With pilot oil supply **X internal**, you must always use a preload valve due to the negative overlap of the control spools C, HC, F, G, H, P and T.

Switching time adjustment, pressure reducing valve, preload valve

Switching time adjustment "S/S2"

The switching time of the main valve (1) is influenced by using a twin throttle check valve (2), type Z2FS 6.

Symbol (3) shows the switching time adjustment "S" (supply control), symbol (4) shows the switching time adjustment "S2" (discharge control)

Type H-4WEH 10 ..4X/...S or S2

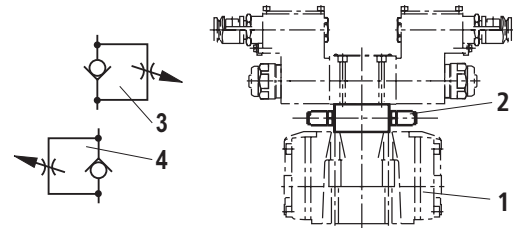

Pressure reducing valve "D3"

With the design internal pilot oil supply (ET or E) or external pilot oil supply and a pilot pressure of more than 250 bar, the valve must be ordered with a pressure reducing valve (5), type ZDR6PO, and a throttle insert "B10".

Ordering code: "B10..D3"

Type H-4WEH 10 ..4X/.../..D3

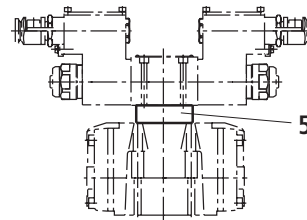

Preload valve "P4,5" (not for size 10)

In case of valves with depressurized circulation and internal pilot oil supply, a preload valve is required in the P channel of the main valve in order to build up the minimum pilot pressure.

Ordering code: "P4,5"

The pressure differential of the preload valve is to be added to the pressure differential of the main valve (see characteristic curves) to result in one total value.

The cracking pressure amounts to approx. 4.5 bar.

Δp - q_v characteristic curve

(measured with HLP46, $\vartheta_{oil} = 40 \text{ }^\circ\text{C} \pm 5 \text{ }^\circ\text{C}$)

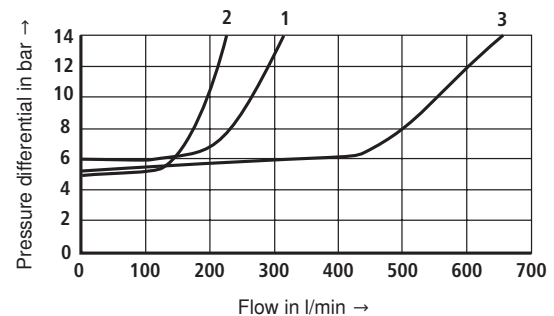

1 = size 16 2 = size 25 3 = size 32

Dimensions: Type H-4WEH 10... (dimensions in mm)

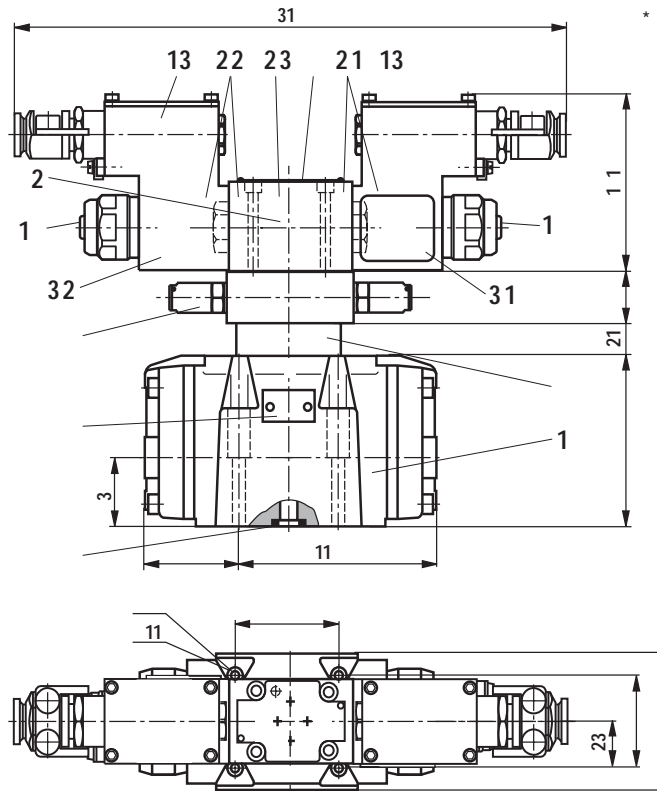

* Plus 2 x 80 mm for detaching the solenoid coils

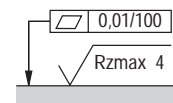

Required surface quality of the valve contact surface

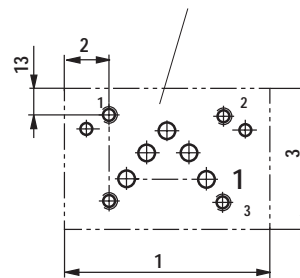

Subplates

- **without** ports X, Y G 534/01 FE/ZN (G3/4)
- **with** ports X, Y G 535/01 FE/ZN (G3/4)
G 536/01 FE/ZN (G1)

with dimensions as in the data sheet 45054
(must be ordered separately)

Item explanations and information on the subplates,
see page 24

Valve mounting screws

For reasons of stability, exclusively use the following valve mounting screws:

4 hexagon socket head cap screws
ISO 4762-M6x45-10.9-flZn-240h-L
(friction coefficient total: 0.09-0.14 according to VDA 235-101)
(must be ordered separately)

Dimensions: Type H-4WEH 16... (dimensions in mm)

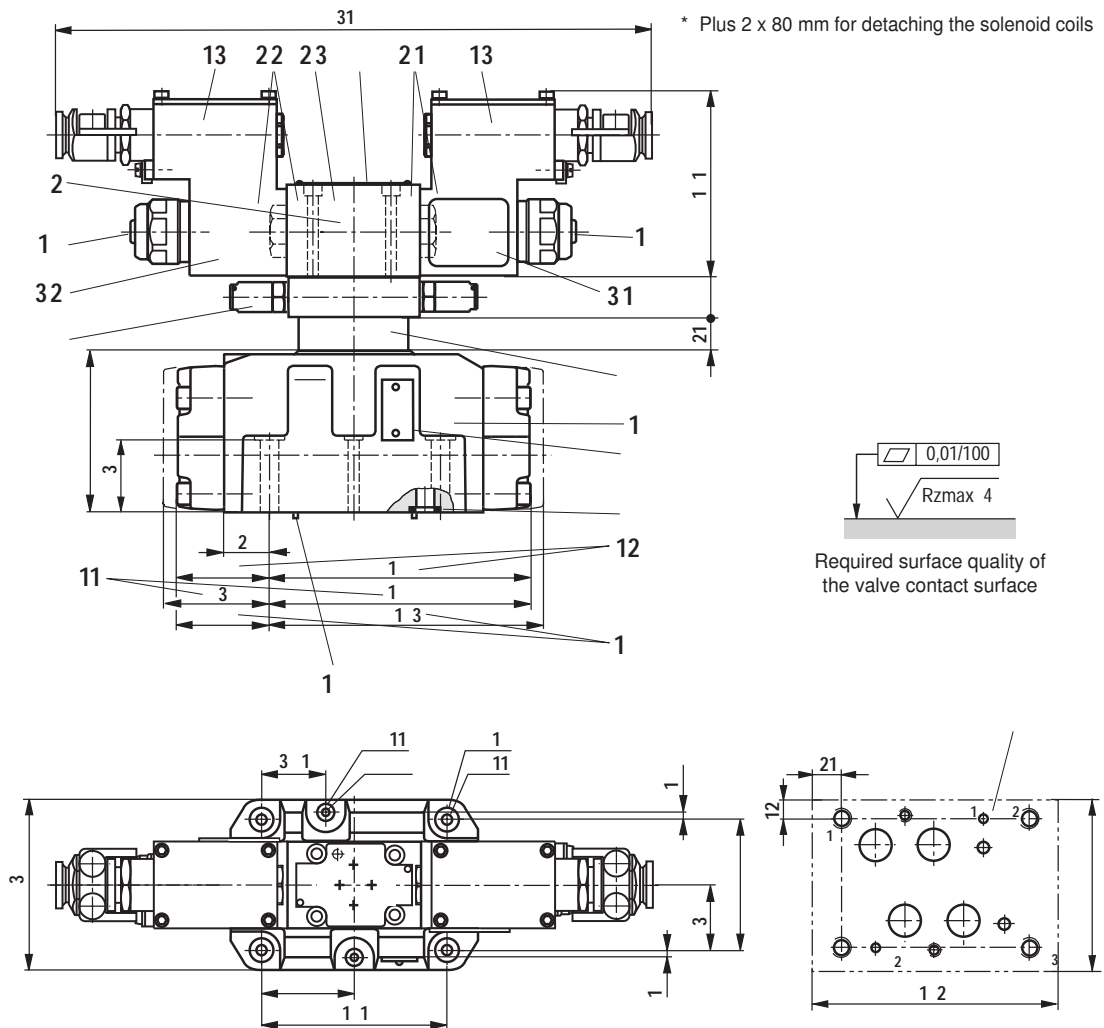

Subplates

- G 172/01 FE/Zn (G3/4)
- G 172/02 FE/Zn (M27 x 2)
- G 174/01 FE/Zn (G1)
- G 174/02 FE/Zn (M33 x 2)
- G 174/08 FE/Zn (flange)

with dimensions as in the data sheet 45056
(must be ordered separately)

Item explanations and information on the subplates,
see page 24

Valve mounting screws

For reasons of stability, exclusively use the following valve mounting screws:

4 hexagon socket head cap screws
ISO 4762-M10x60-10.9-flZn-240h-L
(friction coefficient total: 0.09-0.14 according to VDA 235-101)

2 hexagon socket head cap screws
ISO 4762-M6x60-10.9-flZn-240h-L
(friction coefficient total: 0.09-0.14 according to VDA 235-101)
(must be ordered separately)

Dimensions: Type H-4WEH 25... (dimensions in mm)

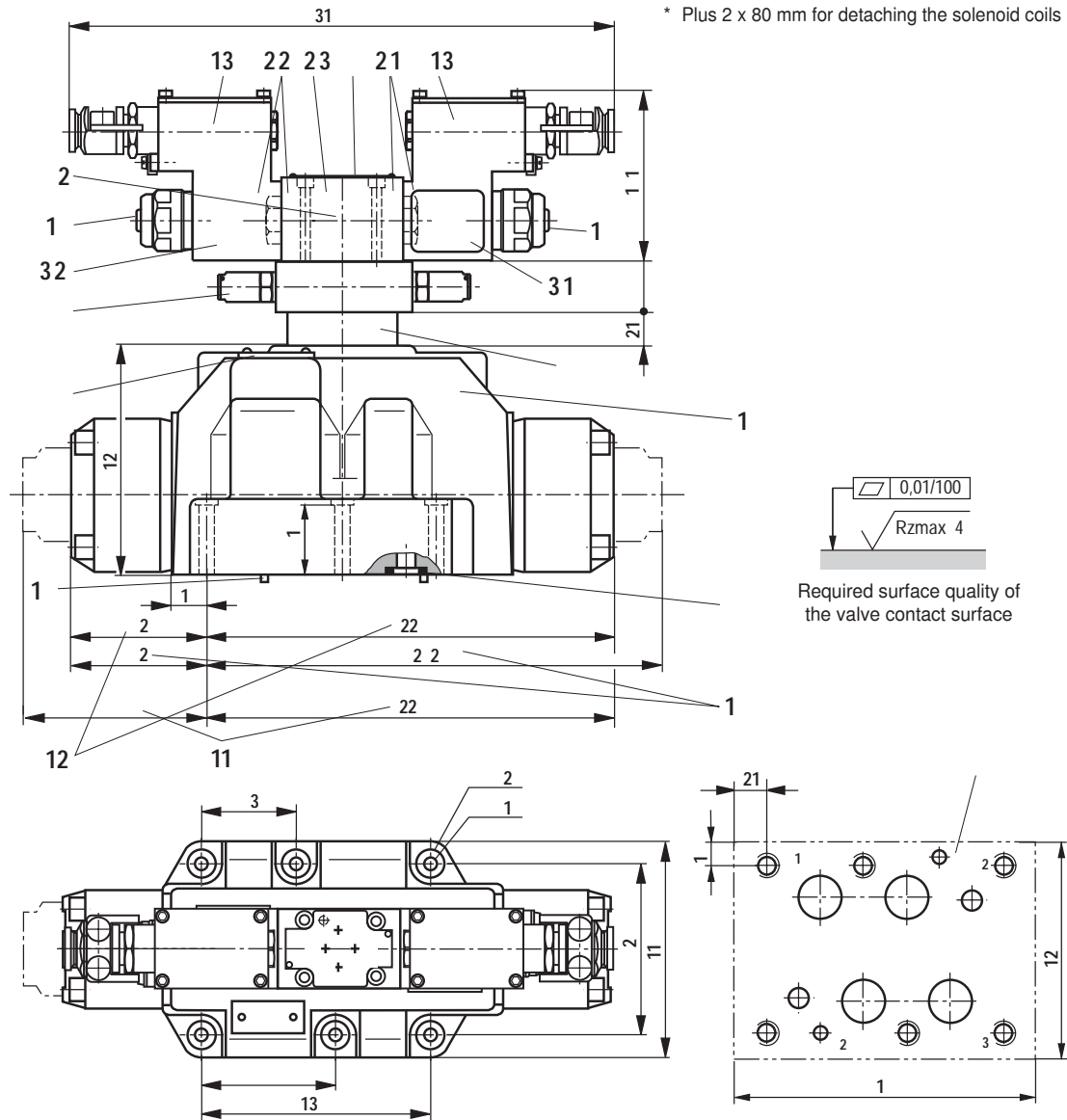

Subplates

- G 151/01 FE/Zn (G1)
- G 154/01 FE/Zn (G1 1/4)
- G 154/08 FE/Zn (flange)
- G 156/01 FE/Zn (G1 1/2)

with dimensions as in the data sheet 45058
(must be ordered separately)

Valve mounting screws

For reasons of stability, exclusively use the following valve mounting screws:

6 hexagon socket head cap screws
ISO 4762-M12x60-10.9-fZn-240h-L
(friction coefficient total: 0.09-0.14 according to VDA 235-101)
 (must be ordered separately)

Item explanations and information on the subplates,
see page 24

Dimensions: Type H-4WEH 32... (dimensions in mm)

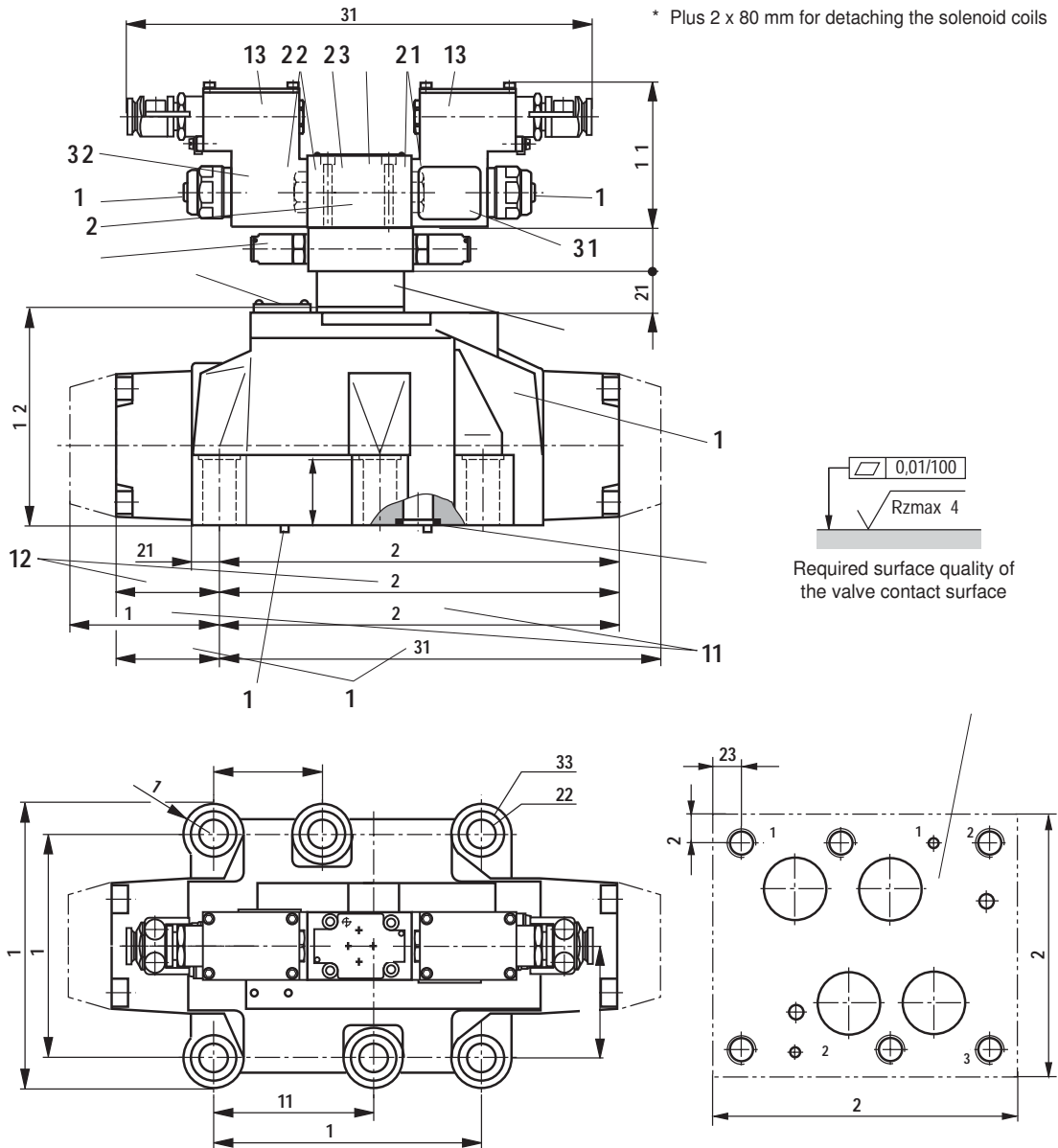

Subplates

G 157/01 FE/Zn (G1 1/2)
 G 157/02 FE/Zn (M48 x 2)
 G 158/10 FE/Zn (flange)
 with dimensions as in the data sheet 45060
 (must be ordered separately)

Item explanations and information on the subplates,
 see page 24

Valve mounting screws

For reasons of stability, exclusively use the following valve
 mounting screws:
6 hexagon socket head cap screws
ISO 4762-M20x80-10.9-flZn-240h-L
 (friction coefficient total: 0.09-0.14 according to VDA 235-101)
 (must be ordered separately)

Dimensions: Item explanations and notice

Item explanations regarding the unit dimensions on pages 20 to 23

- 1 Main valve
- 2 Pilot control valve type 4WE 6...XE according to data sheet 23178-XE-B2
- 2.1
 - Pilot control valve type 4WE 6 D... (1 solenoid "a") for main valves with Control spools C, D, K, Z Control spool HC, HD, HK, HZ
 - Pilot control valve type 4WE 6 JA... (1 solenoid "a") for main valves with control spools EA, FA, etc., spring return
- 2.2
 - Pilot control valve type 4WE 6 Y... (1 solenoid "b") for main valves with Control spool Y Control spool HY
 - Pilot control valve type 4WE 6 JB... (1 solenoid "b") for main valves with control spools EB, FB, etc., spring return
- 2.3
 - Pilot control valve type 4WE 6J... (2 solenoids) for main valves with 3 spool positions, spring-centered
- 3.1 Valve solenoid "a"
- 3.2 Valve solenoid "b"
- 4 Switching time adjustment, optional
- 5 Pressure reducing valve, optional
- 6 Machined valve contact surface
Porting pattern according to:
DIN 24340-A10 and
ISO 4401-05-05-0-05 for size 10
DIN 24340-A16 and
ISO 4401-07-07-0-05 for size 16
DIN 24340-A25 and
ISO 4401-08-08-0-05 for size 25
DIN 24340-A32 and
ISO 4401-10-09-0-05 for size 32
- 7 Name plate for the pilot control valve
- 8 Name plate for the complete valve
- 9 R-rings/O-rings
- 10 2-spool position valves with spring end position in the main valve (C, D, K, Z)
- 11 2-spool position valves with spring end position in the main valve (Y)
- 12 3-spool position valves, spring-centered
2-spool position valves with hydraulic end position in the main valve
- 13 Terminal box
- 14 Locking pin
- 15 Manual override, optional

Important:

Subplates are no components in the sense of directive 94/9/EC and can be used after the manufacturer of the overall system has assessed the risk of ignition.

The G...FE/ZN versions are free from aluminum and/or magnesium and galvanized.

© This document, as well as the data, specifications and other information set forth in it, are the exclusive property of Bosch Rexroth AG. It may not be reproduced or given to third parties without its consent. The data specified above only serve to describe the product. No statements concerning a certain condition or suitability for a certain application can be derived from our information. The information given does not release the user from the obligation of own judgment and verification. It must be remembered that our products are subject to a natural process of wear and aging.