



ROEMHELD
HILMA ■ STARK

Issue 1-11 E

B 1.8806

Swing Clamps without Swing Stroke

top flange, reinforced swing mechanism, position monitoring optional, double acting, max. operating pressure 350 bar

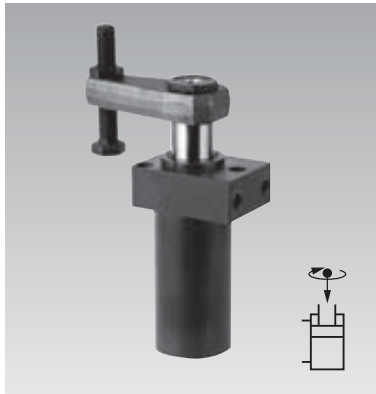

Advantages

- Swing motion without axial stroke
- Swinging in into small recesses
- Compact flange design
- Reinforced swing mechanism
- Optional position monitoring electrical or pneumatic
- Alternatively pipe thread or drilled channels
- FKM wiper standard
- Metallic wiper optional

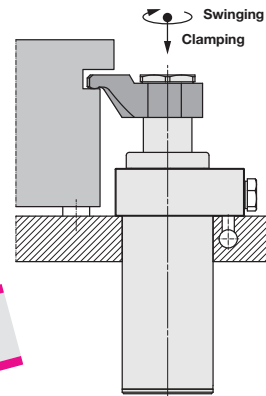

Metallic wiper optional

Application

Hydraulic swing clamps are used for clamping of workpieces, when it is essential to keep the clamping area free of straps and clamping components for unrestricted workpiece loading and unloading.

Using this version without swing stroke, the clamping arm swings in one level and thereby allows the clamping of workpieces in recesses that are only insignificantly higher than the clamping arm.

Special features

Swinging without axial stroke

This version can clamp workpieces in recesses that are only insignificantly higher than the clamping arm.

Reinforced swing mechanism

The reinforced swing mechanism without overload protection device endures a collision of the clamping arm with the workpiece during clamping up to a pressure of 100 bar.

Accessory - Position monitoring

As an option, the swing clamps are available with an extended switch rod at the cylinder bottom, where a control cam can be fixed to control the clamping and unclamping position. As accessories pneumatic and electrical position monitorings are available.

Option - Metallic wiper

The optionally available metallic wiper protects the FKM wiper against mechanical damage.

Function

The swing clamp without swing stroke is a double-acting pull-type cylinder where a part of the piston stroke is used to swing the piston rod without axial stroke.

Clamping

1. The piston rod is rotated together with the clamping arm without axial stroke (swing stroke) in the desired direction.
2. After swinging in the clamping arm above the clamping point, the linear clamping stroke will be effected.

Unclamping

1. The clamping arm is lifted linearly above the clamping point (return stroke).
2. The piston rod swings the clamping arm without axial stroke back to the off-position.

Swing direction

Optionally available with clockwise or counter-clockwise swing motion.

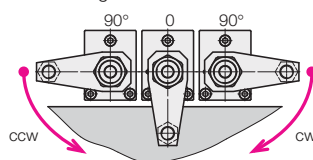

Standard swing angle is 90°

Special swing angles between 20° and 70° are available on request.

Connecting possibilities

Pipe thread

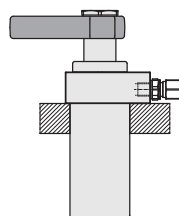

Drilled channels

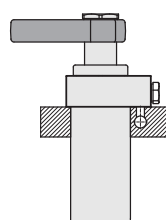

Versions

DH, DM: without switch rod

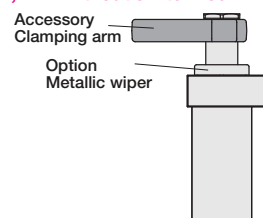

MH, MM: with switch rod

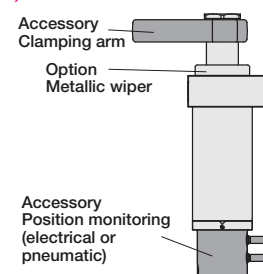

Important notes

See page 3.

Dimensions Technical data

without switch rod

189X-NXXX-XX **DH**
DM

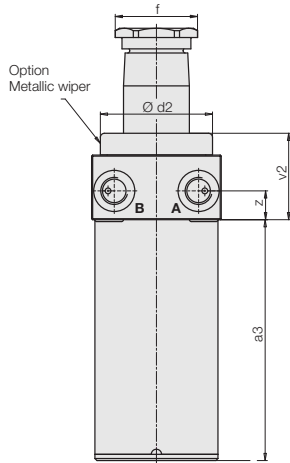

with switch rod

189X-NXXX-XX **MH**
MM

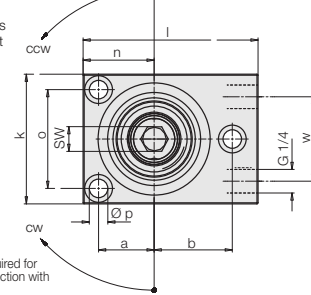
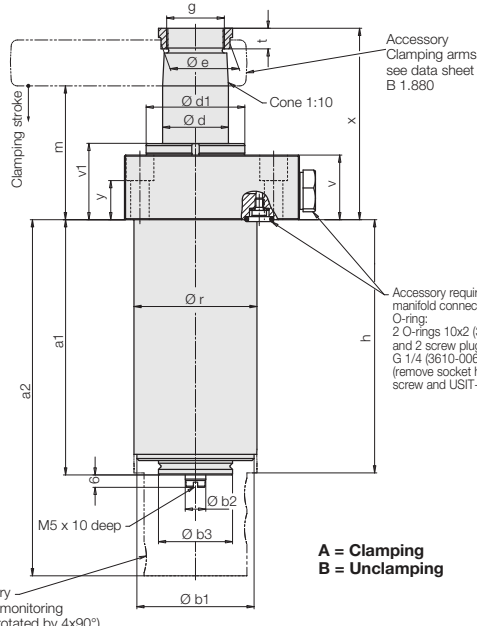

Connecting scheme

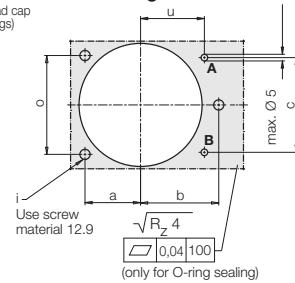

A = Clamping
B = Unclamping

Effective clamping force F_{Sp} as a function of the clamping pressure p

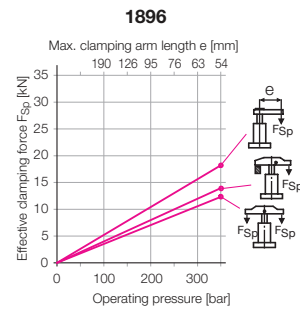
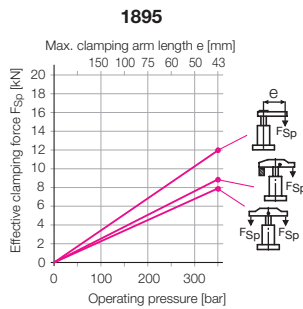
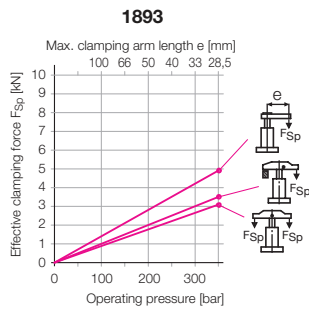

Dimensions Technical data

Size		1893	1895	1896
Max. force to pull at 350 bar	[kN]	6.1	15.8	24.7
Effective clamping force	[kN]		see diagram	
Clamping stroke	[mm]	12	16	20
Operating pressure, min.	[bar]	50	50	50
Max. oil flow rate*	[cm ³ /s]	5...9	5...32	5...60
Oil volume/stroke	[cm ³]	5.6	21.8	40.8
Oil to return	[cm ³]	9.4	34.7	65.9
Oil to return with extended piston rod	[cm ³]	8.4	33.4	64.4
a	[mm]	20	27	37
a1	[mm]	107.5	132.5	175.6
a2	[mm]	148.5	181.5	230.6
a3	[mm]	99.5	125.5	168.6
b	[mm]	30	38	50
Ø b1	[mm]	41.8	57	77
Ø b2 f7	[mm]	10	10	10
Ø b3 f7	[mm]	30	36	36
c	[mm]	32	46	62
Ø d	[mm]	20	32	40
Ø d1	[mm]	38	48	60
Ø d2	[mm]	43	54.5	75
Ø e	[mm]	23.5	33.5	45
f	[mm]	30	40	55
g	[mm]	M 18x1.5	M 28x1.5	M 35x1.5
h	[mm]	106.5	131.5	174.6
i	[mm]	M 6	M 8	M 10
k	[mm]	50	63	85
l	[mm]	70	85	110
m -1	[mm]	55	65	67
n	[mm]	26.5	34.5	47
o	[mm]	37	48	65
Ø p	[mm]	6.6	9	11
Ø r -0.1	[mm]	44.8	59.8	79.8
Ø s +1	[mm]	45	60	80
t	[mm]	9	10	11
u	[mm]	26.5	31	40
v	[mm]	26.4	31.4	29.4
v1	[mm]	31	37	35
v2	[mm]	36	42	40
w	[mm]	28	41	55
x	[mm]	76	93	101
y	[mm]	18	19	15
z	[mm]	14	14	12
SW	[mm]	8	12	17

Part no.

Swing direction 90° cw	1893-N90R-12XX	1895-N90R-16XX	1896-N90R-20XX
Swing direction 90° ccw	1893-N90L-12XX	1895-N90L-16XX	1896-N90L-20XX

Special swing angles between 20° and 70° on request.

XX: Version

DH = without switch rod, without metallic wiper
DM = without switch rod, with metallic wiper
MH = with switch rod, without metallic wiper
MM = with switch rod, with metallic wiper

* Do not use manually-operated pumps, since a continuous flow rate is required.

Clamping arms and other accessories see data sheet B 1.880.

Important notes

Swing clamps must only be used for clamping of workpieces in industrial applications and may only be operated with hydraulic oil. They can generate very high forces. The workpiece, the fixture or the machine must be in the position to compensate these forces.

In the effective area of piston rod and clamping arm there is the danger of crushing. The manufacturer of the fixture or the machine is obliged to provide effective protection devices.

The swing clamp has no overload protection device. When mounting the clamping arm, the clamping arm or the hexagon socket in the piston have to be backed up for tightening and untightening the fixing nut. During loading and unloading of the fixture and during clamping a collision with the clamping arm has to be avoided.

Remedy: Mount position adaptor.
 Operating conditions, tolerances and other data see data sheet A 0.100.

Accessory Position monitoring

Pneumatic position monitoring

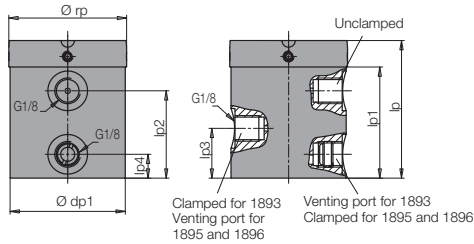

Electrical position monitoring

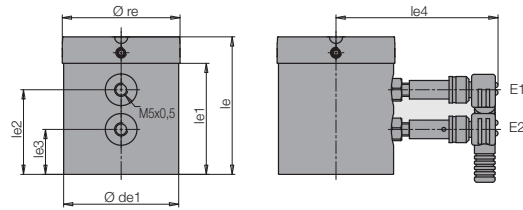

Function chart

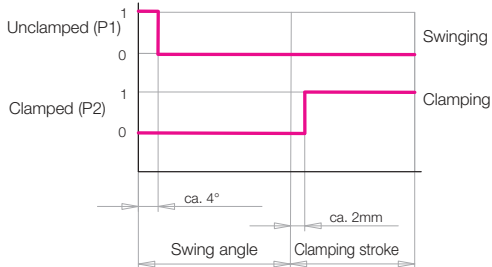

Function chart

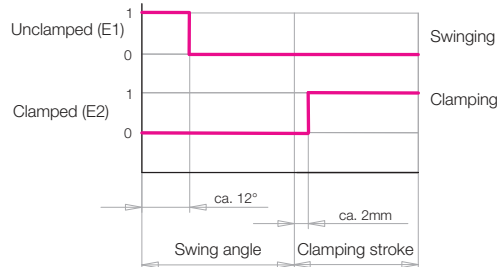

Size		1893	1895	1896
lp	[mm]	52	59	65
lp1	[mm]	42	50	56
lp2	[mm]	33	40	46
lp3	[mm]	18,8	22,8	23,8
lp4	[mm]	9	9	11
Ø rp	[mm]	44,5	59,8	79,8
Ø dp1	[mm]	43,5	50	50
le	[mm]	52	59	65
le1	[mm]	42	50	56
le2	[mm]	32	40	46
le3	[mm]	17	22	22
le4	[mm]	approx. 62	approx. 62	approx. 62
Ø re	[mm]	44,5	59,8	79,8
de1	[mm]	43,5	50	50

Part no.

Pneumatic position monitoring, complete	0353-896	0353-892	0353-903
Electrical position monitoring			
- without switch	0353-897	0353-893	0353-902
- with standard switch	0353-909	0353-908	0353-907

Control by pneumatic pressure switch

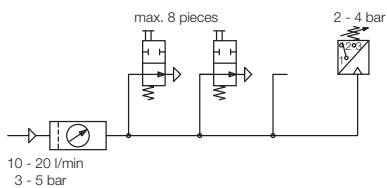

For the evaluation of the pneumatic pressure built-up standard pneumatic pressure switches can be used. It is possible to control with one pressure switch up to 8 position monitorings connected in series (see circuit diagram). It has to be considered that process-safe functioning of pneumatic position monitorings is only guaranteed with throttled air and system pressure. The nominal values are indicated below technical data.

Technical data

for pneumatic pressure switches

Port		G 1/8
Nominal diameter	[mm]	2
Max. air pressure	[bar]	10
Range of operating pressure	[bar]	3...5
Differential pressure* at 3 bar system pressure	[bar]	min. 1.5
Differential pressure* at 5 bar system pressure	[bar]	min. 3.5
Air flow**	[l/min]	10...20

- * Pressure drop when controlling the function „Clamped“, if one or several position monitorings are not operated.
- ** For measuring the air flow rate appropriate devices are available. Please contact us.

Delivery

The position monitorings are not delivered mounted at the swing clamp. The body, the signal sleeve and two inductive proximity switches with plug are included in the delivery.

Technical data

for inductive proximity switches

Operating voltage UB	[V DC]	10 ... 30
Switching function		interlock
Output		PNP
Body material		Stainless steel
Code class as per DIN 40050		IP 67
Environmental temperature	[°C]	-25 ... +70
Connection type		Plug
LED Function display		Yes
Constant current max.	[mA]	150
Nominal switch distance	[mm]	0.8
Short circuit proof		yes

Part no.

3829-198

Installation

The control cam can be mounted at the switch rod in 4 x 90° position, thus allowing a 4 x 90° rotation of the position monitoring. The position monitoring is exactly centered at the swing clamp and is fixed after radial adjustment of the unclamping position with four threaded pins.