

Electric Drives
and Controls

Hydraulics

Linear Motion and
Assembly Technologies

Pneumatics

Service

Rexroth
Bosch Group

Proportional directional valve, direct operated, with *pQ* functionality

RE 29014/03.13
Replaces: 12.12

1/18

Type STW 0195, type STW 0196

STW 0195: Size 6
Component series 2X

STW 0196: Size 10
Component series 1X

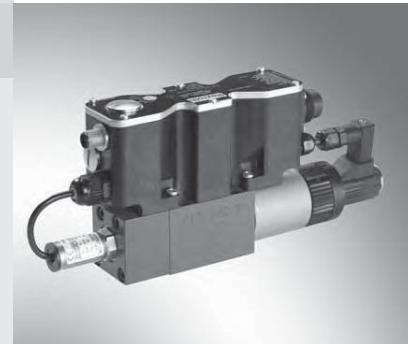

Table of contents

Contents	Page
Features	1
Ordering code, symbols	2
Set-up, function, section	3
Technical data	4, 5
Electrical connections, allocation	6, 7
Characteristic curves	8 ... 13
Device dimensions	14 ... 16
Accessories (not included in the scope of delivery)	16, 17
Project planning/maintenance instructions/ additional information	18

Features

– Direct operated 3-way proportional valve with integrated IAC-P digital control electronics, for controlling a pressure in port A	1
– Completely adjusted unit consisting of position-controlled valve, pressure sensor and field bus connection	2
– Operation via a proportional solenoid with central thread and detachable coil	3
– Valve spool, position-controlled	4, 5
– Integrated pressure sensor plate (optional)	6, 7
– For subplate mounting: Porting pattern according to ISO 4401	8 ... 13
– Analog interfaces for command and actual values	14 ... 16
– Design for CAN bus with CANopen protocol DS 408 or Profibus DP	16, 17
– Separate connectors for power supply and bus connection	18
– Quick commissioning via PC and WINPED commissioning software	

Ordering code

STW	0195	-2X/	V	-24		- *
With integrated digital electronics and pQ functionality; size 6						
Component series 20 to 29 (20 to 29: Unchanged installation and connection dimensions)		= 2X	Further details in plain text			
Rated flow			Interface A6 or F6			
P → A	10 l/min, A → T	20 l/min	= 1	A6 = ±10 VDC		
P → A	20 l/min, A → T	20 l/min	= 2	F6 = 4 to 20 mA		
Seal material			Bus interface			
FKM seals		= V	C = CANBus DS - 408			P = Profibus DP V0/V1
			Supply voltage			
			24 = Direct voltage 24 V			
			Pressure rating of the integrated pressure sensor			
			3 = Nominal pressure 50 bar			
			5 = Nominal pressure 160 bar			
			8 = Nominal pressure 250 bar			

STW	0196	-1X/ 1	V	-24		- *
With integrated digital electronics and pQ functionality; size 10						
Component series 10 to 19 (10 to 19: Unchanged installation and connection dimensions)		= 1X	Further details in plain text			
Rated flow			Interface A6 or F6			
P → A	65 l/min,		A6 = ±10 VDC			
A → T	60 l/min,	= 1	F6 = 4 to 20 mA			
B → T	60 l/min		Bus interface			
Seal material			C = CANBus DS - 408			P = Profibus DP V0/V1
FKM seals		= V	Supply voltage			
			24 = Direct voltage 24 V			
			Pressure rating of the integrated pressure sensor			
			3 = Nominal pressure 50 bar			
			5 = Nominal pressure 160 bar			
			8 = Nominal pressure 250 bar			

Symbols

Type STW0195...

Type STW0196...

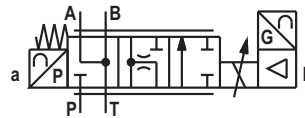
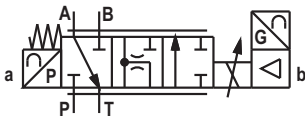

Set-up, function, section

Set-up

The IAC-P valve basically consists of:

- Housing (1) with connection surface
- Control spool (2) with compression spring (3)
- Solenoid and pole tube (4) with central thread
- Position transducer (5)
- Pressure sensor (6)
- Integrated IAC-P digital control electronics (7) with bus connection (X2) and central connector (X1).

Functional description

- If solenoids (4) are not operated, spool position A → T (with type STW 0196-1X/1 additionally B → T)
- Functions:
 - Flow control (Q)
 - Pressure control (p)
 - Substitutional closed-loop control p/Q
- The command value can alternatively be specified via an analog interface (X1) or via the field bus interface (X2, X3).
- The actual value signals are provided via an analog interface (X1) and can additionally be read out via the field bus (X2, X3).
- The controller parameters are set via the field bus (X2, X3).
- Separate supply voltage for bus/controller and power part (output stage) for safety reasons.

The digital integrated control electronics enables the following fault detection: (diagnosis)

- Cable break of pressure sensor supply line (6)
- Undervoltage
- Cable break of position transducer (5)
- Communication error
- Watchdog
- Cable break of command value inputs

The following additional functions are available:

- Pressure ramp
- Internal command value profile
- Enable function analog/digital
- Error output 24 V

WINPED PC program

To implement the project planning task and to parameterize the IAC-P valves, the user may use the WINPED commissioning software (see accessories).

- Parameterization
- Diagnosis
- Comfortable data management on a PC
- PC operating systems: Windows 2000 or Windows XP

Q_{command}	Q control	p closed-loop control
< 12 mA	A → T	Inactive
> 12 mA	Substitutional closed-loop control: (A → T or P → A) Q control (Q_{command}) with pressure limitation (p_{command}) if pressure limitation is active, the following applies: $Q_{\text{actual}} \leq Q_{\text{command}}$	

Functional section of STW 0195–2X

X3 exists only if Profibus is used

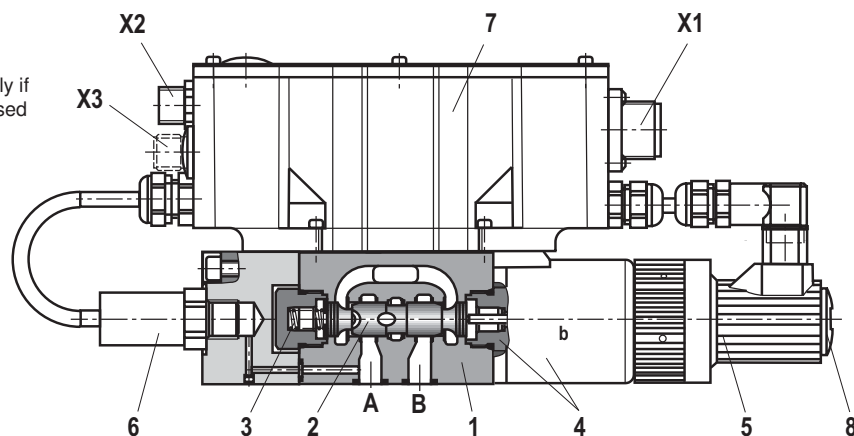

Notice!

Due to the design principle, internal leakage is inherent to the valves, which may increase over the life cycle.

The tank line must not be allowed to run empty. With corresponding installation conditions, a preload valve is to be installed.

Important notice!

The PG fitting (8) must not be opened. Mechanical adjustment of the adjustment nut located below is prohibited and damages the valve!

Technical data (For applications outside these parameters, please consult us.)

general

Valve type		STW195	STW196
Weight	kg	2.4	6.5
Installation position		Any, preferably horizontal	
Ambient temperature range	°C	-20 ... +50	
Storage temperature range	°C	-20 ... +80	

hydraulic (measured using HLP 46; $\dot{v}_{oil} = 40 \text{ }^\circ\text{C} \pm 5 \text{ }^\circ\text{C}$ and $p = 100 \text{ bar}$)

Operating pressure ¹⁾	50 bar	bar	50		
Ports P, A, B	with sensor	160 bar	bar	160	
		250 bar	bar	250	
Port T	with sensor	50 bar	bar	50	
		160 bar	bar	160	
		250 bar	bar	210	
Rated flow $q_{V \text{ rated}}$ at $\Delta p = 5 \text{ bar}$ (see also flow characteristic curve from page 10 onwards)	From P → A	l/min	Spool 1	Spool 2	65
			10	20	
	From A → T	l/min	20	20	A → T, B → T 60
Maximum flow	See characteristic curves performance limit from page 11 onwards				
Hydraulic fluid	See table below				
Hydraulic fluid temperature range (at the valve's working ports)	°C -20 to +80, preferably +40 to +50				
Viscosity range	mm ² /s 20 to 380, preferably 30 to 46				
Maximum admissible degree of contamination of the hydraulic fluid, cleanliness class according to ISO 4406 (c)	Class 20/18/15 ²⁾				
Hysteresis	% ≤ 0.1				
Range of inversion	% ≤ 0.05				
Response sensitivity	% ≤ 0.05				
Zero shift	%10 K		≤ 0.15		
	%100 bar		≤ 0.1		

¹⁾ Operating pressure, dependent on valve and sensor

²⁾ The cleanliness classes specified for the components must be adhered to in hydraulic systems. Effective filtration prevents faults and at the same time increases the life cycle of the components.
For the selection of the filters see www.boschrexroth.com/filter

Hydraulic fluid	Classification	Suitable sealing materials	Standards
Mineral oils and related hydrocarbons	HL, HLP	NBR, FKM	DIN 51524
Flame-resistant – containing water	HFC (Fuchs HYDROTHERM 46M, Petrofer Ultra Safe 620)	NBR	ISO 12922

Important information on hydraulic fluids!

- For more information and data on the use of other hydraulic fluids refer to data sheet 90220 or contact us!
- There may be limitations regarding the technical valve data (temperature, pressure range, life cycle, maintenance intervals, etc.)!
- The flash point of the process and operating medium used must be 40 K greater than the maximum solenoid surface temperature.

- **Flame-resistant – containing water:** Maximum pressure differential per control edge 175 bar. Pressure pre-loading at the tank port > 20 % of the pressure differential; otherwise, increased cavitation.
Life cycle as compared to operation with mineral oil HL, HLP 50 % to 100 %

Technical data (For applications outside these parameters, please consult us.)

electric

Supply voltage	Nominal voltage	VDC	24
	Lower limit value	VDC	19.4
	Upper limit value	VDC	35
Maximum admissible residual ripple		V _{pp}	2
Current consumption	I_{max}	A	2
	Pulse current	A	3
Command value signals		mA	4 to 20 or via CAN bus
Duty cycle ¹⁾		%	100
Maximum coil temperature ²⁾		°C	Up to 150
Protection class of the valve according to EN 60529			IP 65 with mating connector correctly mounted and locked

¹⁾ Connect the valve to the supply voltage only when this is required for the functional sequence of the machine.

²⁾ Due to the temperatures occurring at the surfaces of the solenoid coils, the European standards ISO 13732-1 and EN ISO 4413 need to be adhered to.

Sensor technology

Valve type		STW 195 (size 6) and STW 196 (size 10)			
Measurement range	p_N	bar	50	160	250
Overload protection	p_{max}	bar	120	320	500
Bursting pressure	p	bar	550	800	1200
Compensation error	Zero point	< 0.15 % of full scale			
	End value	< 0.3 %			
Temperature coefficient in nominal temperature range					
Greatest temperature coefficient of zero point		< 0.2 % / 10 K			
Greatest temperature coefficient of the range		< 0.2 % / 10 K			
Characteristic curve deviation		< 0.2 %			
Hysteresis		< 0.1 %			
Repetition accuracy		< 0.05 %			
Setting time (10 - 90 %)		t	< 2 ms		
Long-term drift (1 year) at reference conditions		< 0.2 %			
Conformity		CE according to EMC directive 89/336/EEC, 93/68/EEC, 93/44/EEC			

Electrical connections, allocation

Connector allocation X1, 11-pole + PE according to DIN EN 175201-804

Pin	No. and/or litz wire color ¹⁾	Interface A6 allocation	Interface F6 allocation
1	1	24 VDC ($u(t) = 19.4 \text{ V} \dots 35 \text{ V}$), $I_{\text{max}} = 1.7 \text{ A}$ (for output stage)	
2	2	0 V Δ load zero, reference for pins 1 and 9	
3	White	Enable input 9 ... 35 V Δ enable on	
4	Yellow	$\pm 10 \text{ V}$ command value Q $R_{\text{e}} > 50 \text{ k}\Omega$	4...20 mA command value Q $R_{\text{e}} = 100 \Omega$
5	Green	Reference for command values Q and p	
6	Purple	$\pm 10 \text{ V}$ actual value Q	4...20 mA actual value Q (load resistance max. 300 Ω)
7	Pink	0 ... 10 V command value p $R_{\text{e}} > 50 \text{ k}\Omega$	4...20 mA command value p $R_{\text{e}} = 100 \Omega$
8	Red	0 ... 10 V actual value p	4...20 mA actual value p (load resistance max. 300 Ω)
9	Brown	Control voltage, level same as pin 1, $I_{\text{max}} = 0.3 \text{ A}$ (for signal part and bus)	
10	Black	0 V reference potential for pins 3, 6, 8 and 11 (connected with pin 2 in valve)	
11	Blue	Error output 24 V (19.4 V ... 35 V), 200 mA max. load	
PE	Green-yellow	Connected to cooling element and valve housing	

Connect shield on PE only on the supply side!

¹⁾ Litz wire colors of connection line for mating connector with cable set (see accessories)

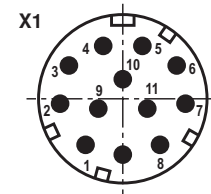

Connector allocation X2, CAN bus, (coding A), M12 x 1, 5-pole, pins

Pin	Allocation
1	n.c.
2	n.c.
3	CAN_GND
4	CAN_H
5	CAN_L

Transmission rate kbit/s 20 to 1000
Bus address 1 to 127
CAN-specific settings:
Baud rate and identifier must be set via the bus system.

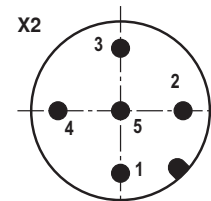

Connector allocation for Profibus DP, "X2"/"X3" (coding B), M12 x 1, 5-pole, socket/pins

Pin	Allocation
1	+5 V
2	RxD/TxD-N (A line)
3	D GND
4	RxD/TxD-P (B line)
5	Shield

Transmission rate up to 12 MBaud
Bus address 1 to 126
Setting via DIL switch

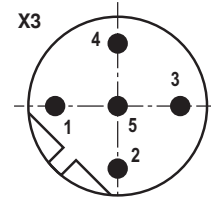
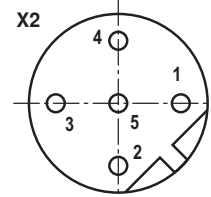

The +5 V voltage of the IAC-P is available for an external terminating resistor.

Notice:

We recommend connecting the shields on both sides via the metal housings of the plug-in connectors. Using connector pins will affect the shielding effect! Internal screens are not required.

Electrical connections, allocation

Block diagram, integrated control electronics

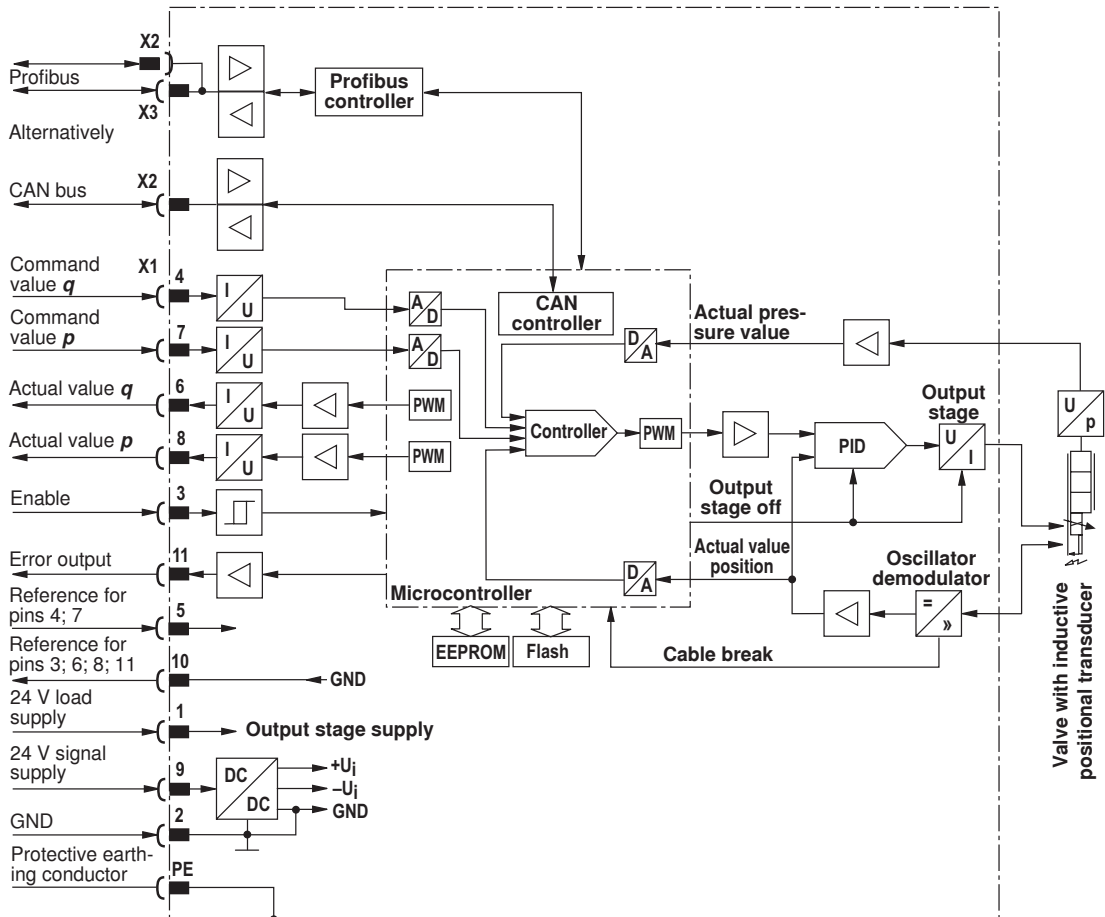

Command value: Command value 12 to 20 mA at pin 4 and reference potential at pin 5 result in flow from P → A.

Command value 4 to 12 mA at pin 4 and reference potential at pin 5 result in flow from A → T.

Actual value: Actual value 12 to 20 mA at pin 6 and reference potential at pin 10 result in flow from P → A.

Actual value 4 to 12 mA at pin 6 and reference potential at pin 10 result in flow from A → T.

Connection line: Recommendation: – Up to 25 m line length for pins 1; 2 and PE: 0.75 mm², otherwise 0.25 mm²
– Up to 50 m line length for pins 1; 2 and PE: 1.00 mm²

External diameter see sketch of mating connector

Characteristic curves: Type STW 0195-2X/1...

Transition function of type STW 0195-2X/1..., A → T

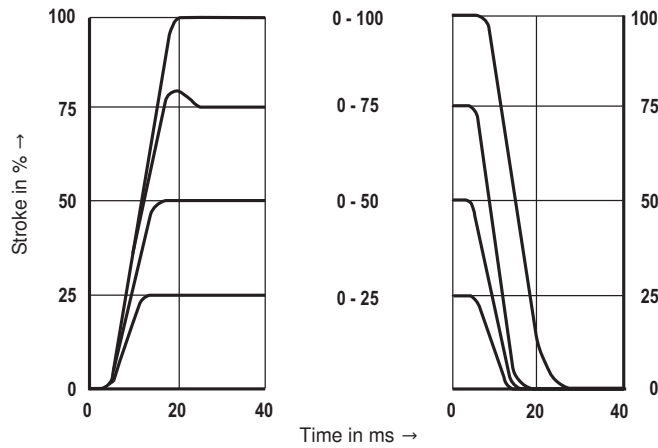

Transition function of type STW 0195-2X/1..., P → A

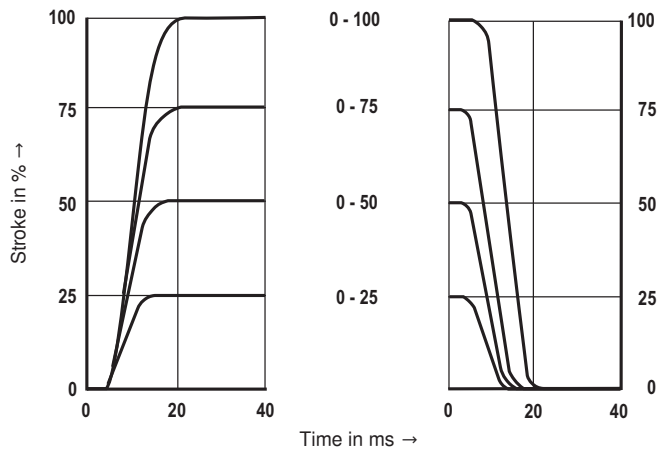

Characteristic curves: Type STW 0196-1X/1...

Transition function of type STW 0196-1X/1..., A → T, B → T

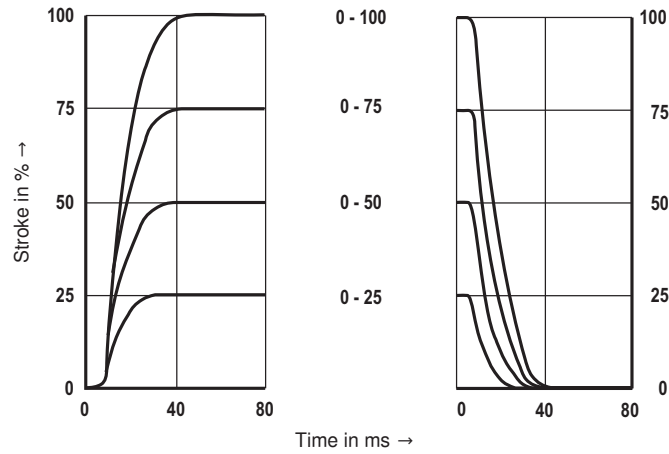

Transition function of type STW 0196-1X/1..., P → A

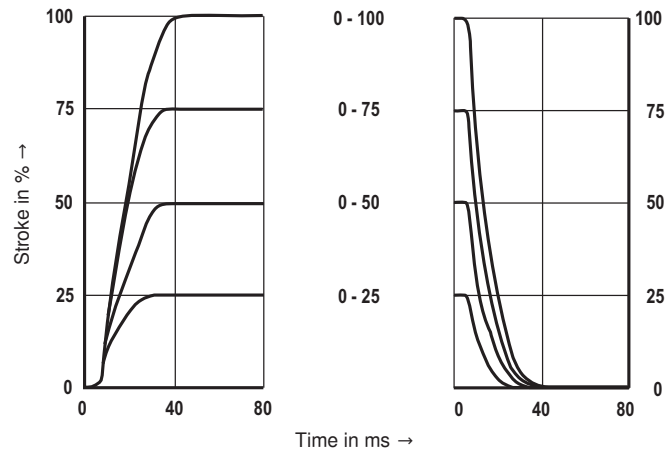

Characteristic curves: Type STW 0195-2X/1... and type STW 0196-1X/1...

Frequency response of type STW 0195-2X/1...

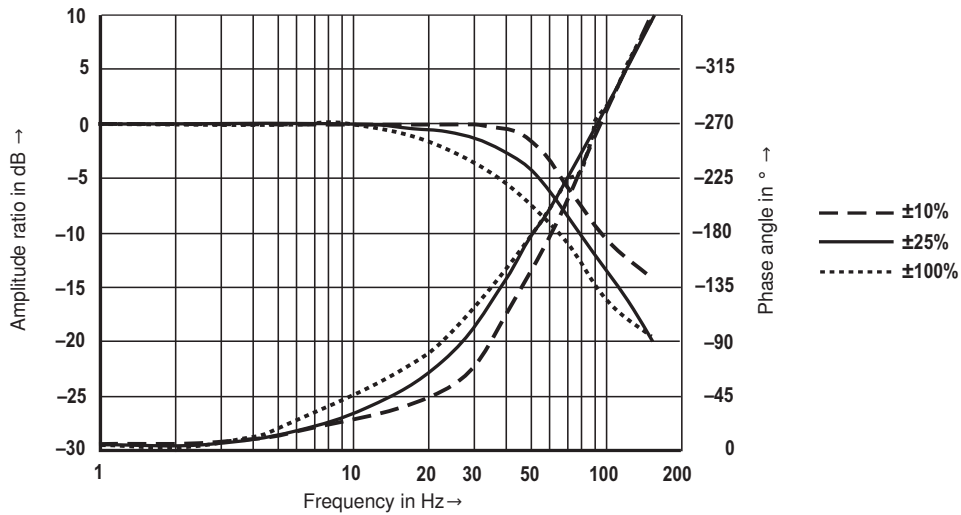

Frequency response of type STW 0196-1X/1...

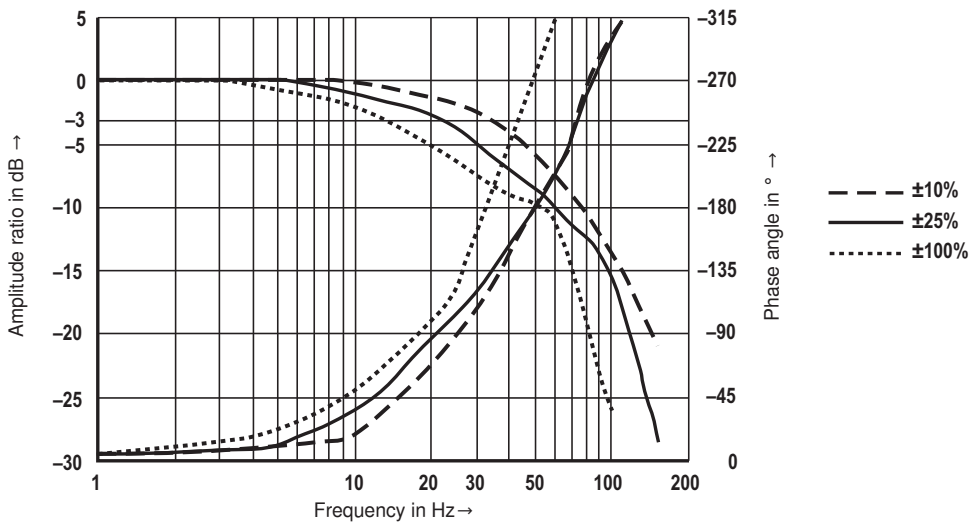

Characteristic curves: Type STW 0195-2X/1...

Performance limit A → T, position-controlled

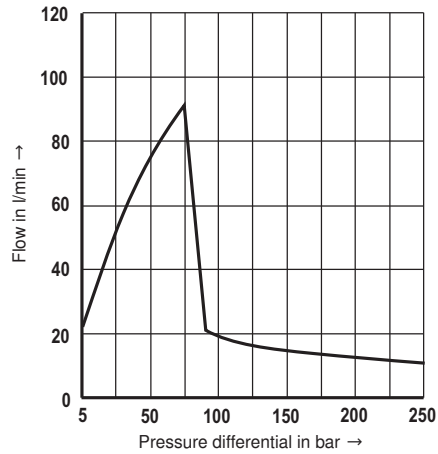

Performance limit P → A, position-controlled

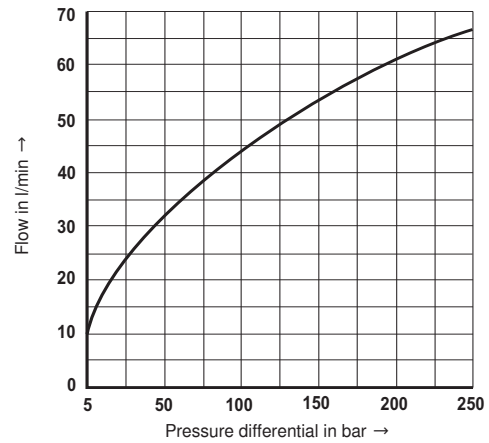

Flow characteristic curve A → T, $\Delta p = 5$ bar

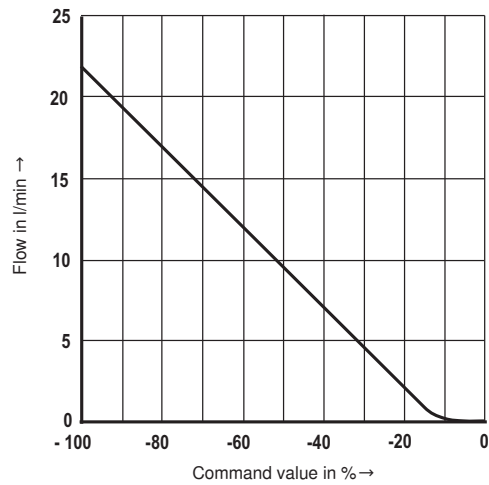

Flow characteristic curve P → A, $\Delta p = 5$ bar

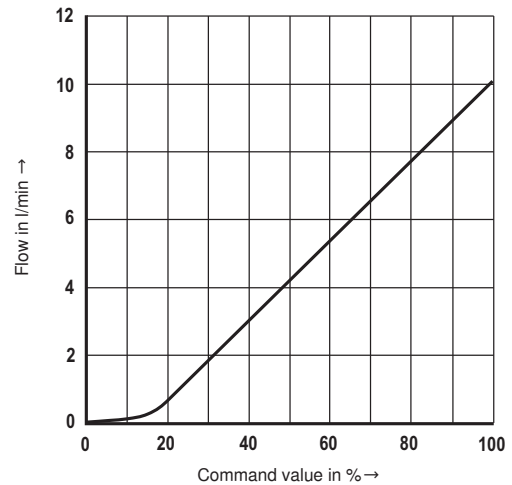

Characteristic curves: Type STW 0195-2X/2...

Performance limit A → T, position-controlled

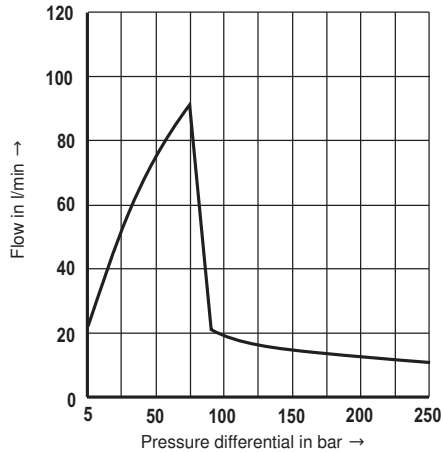

Performance limit P → A, position-controlled

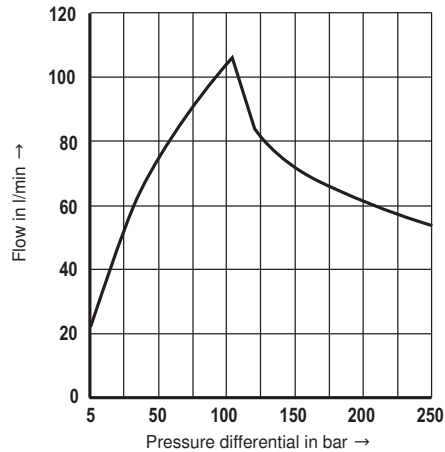

Flow characteristic curve A → T, $\Delta p = 5$ bar

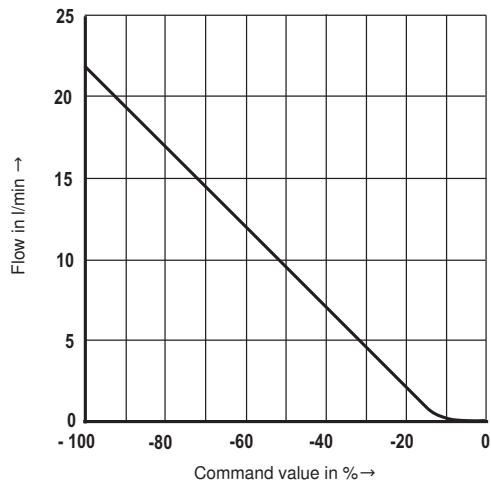

Flow characteristic curve P → A, $\Delta p = 5$ bar

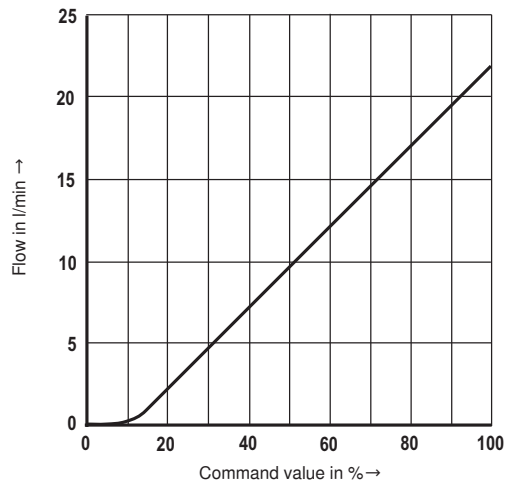

Characteristic curves: Type STW 0196-1X/1...

Performance limit A → T, position-controlled

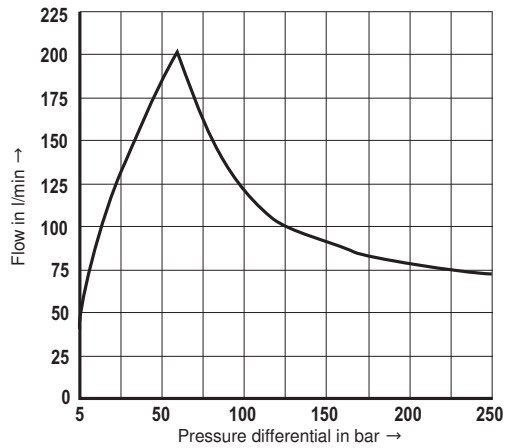

Performance limit P → A, position-controlled

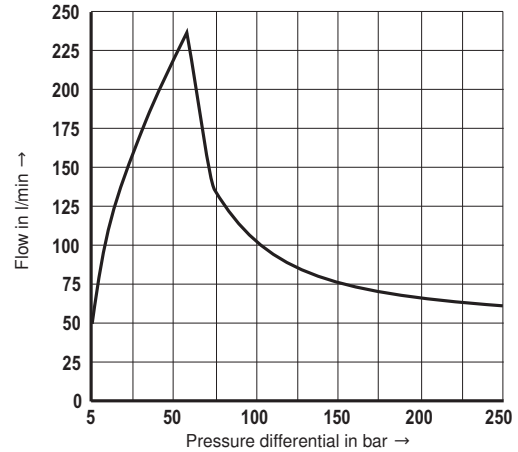

Performance limit B → T, position-controlled

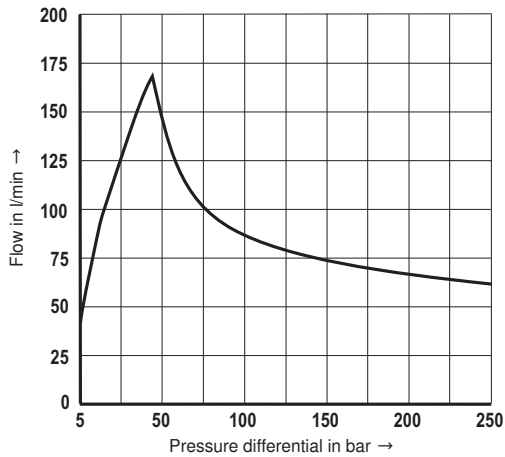

Flow characteristic curve A → T, Δp = 5 bar

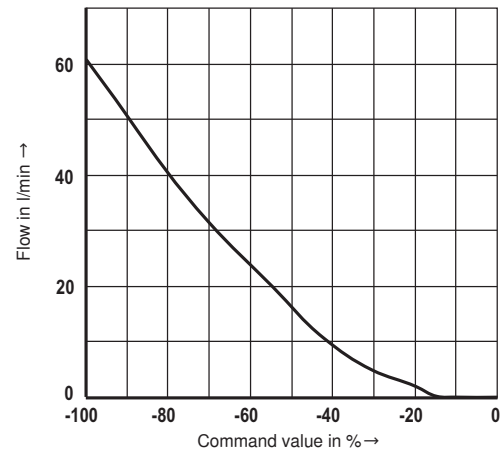

Flow characteristic curve P → A, Δp = 5 bar

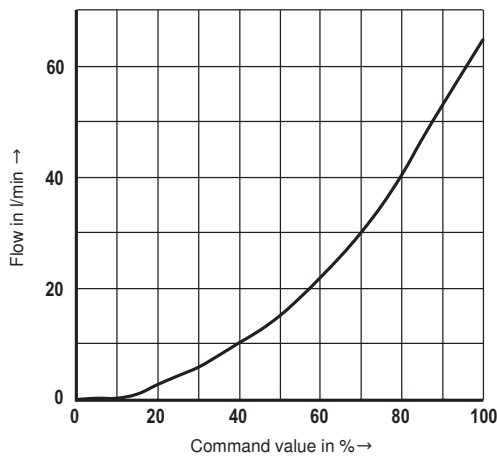

Flow characteristic curve B → T, Δp = 5 bar

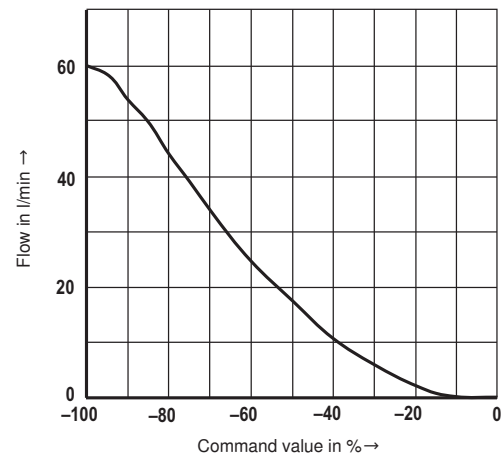

Dimensions: Type STW 0195-2X/1... (dimensions in mm)

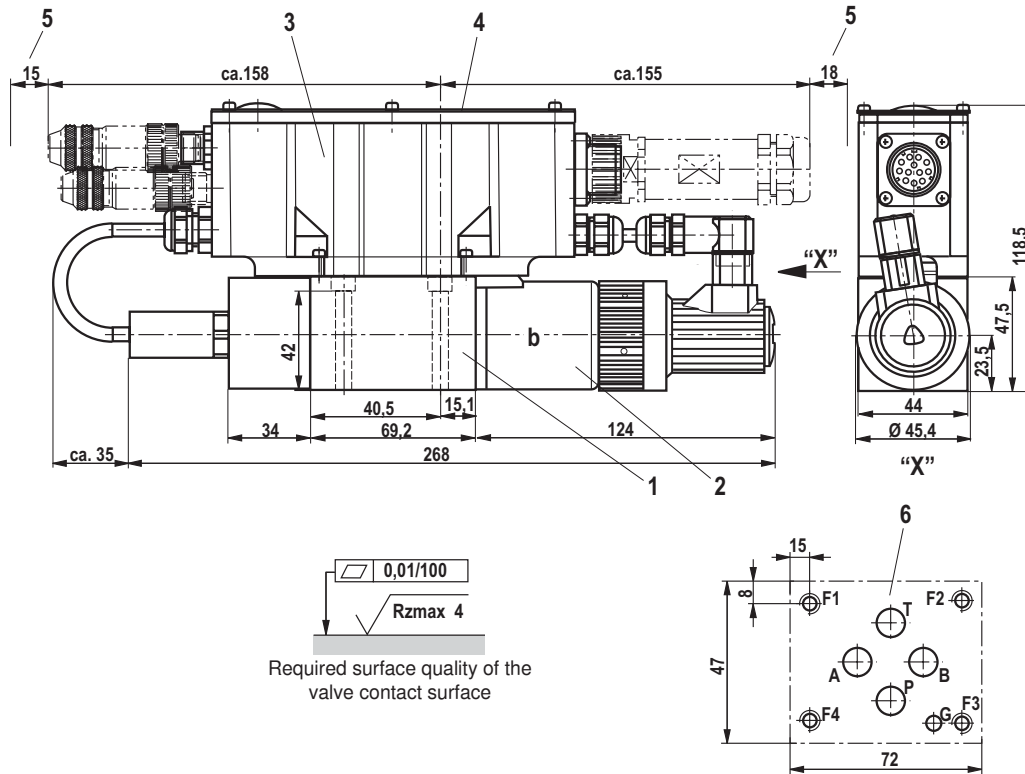

Notice!

The dimensions are nominal dimensions which are subject to tolerances.

- 1 Valve housing
- 2 Proportional solenoid "b" with inductive position transducer
- 3 Integrated digital control electronics
- 4 Name plate
- 5 Space required to remove the connector
- 6 Machined valve contact surface, porting pattern according to ISO 4401-03-02-0-05
Deviating from the standard:
 - Ports P, A, B and T with Ø 8 mm
 - Bore B may not be required since there is no pin in the valve.

Subplates and valve mounting screws see page 16

Dimensions: Type STW 0196-1X/1... (dimensions in mm)

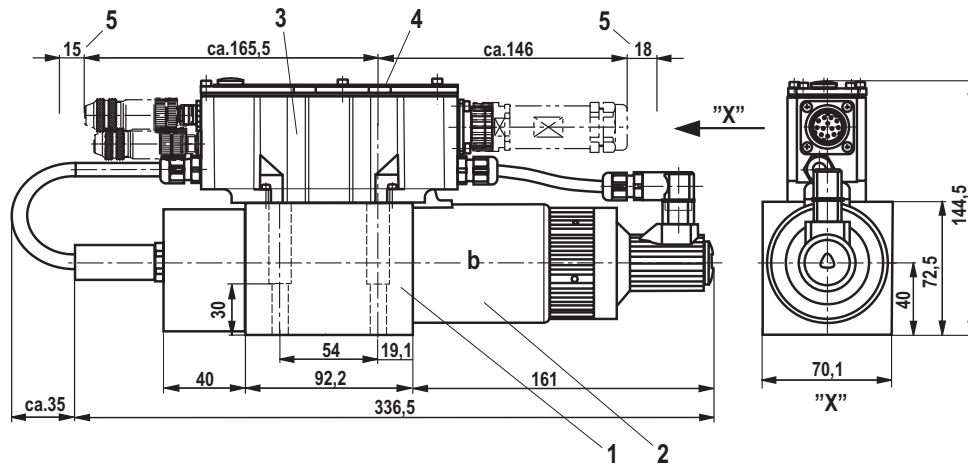

0,01/100
Rzmax 4
Required surface quality of the valve contact surface

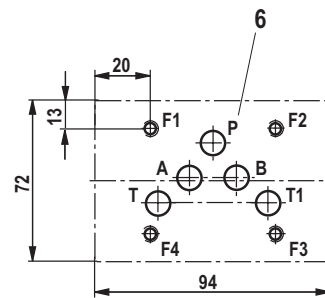

Notice!

The dimensions are nominal dimensions which are subject to tolerances.

- 1 Valve housing
- 2 Proportional solenoid "b" with inductive position transducer
- 3 Integrated digital control electronics
- 4 Name plate
- 5 Machined valve contact surface, porting pattern according to ISO 4401-05-04-0-05
Deviating from the standard:
– Port T1 exists additionally

Subplates and valve mounting screws see page 16

Dimensions

Hexagon socket head cap screws		Material number
Type STW0195	4x ISO 4762 - M5 x 50 - 10.9-fZn-240h-L Tightening torque $M_A = 7 \text{ Nm} \pm 10 \%$ or 4x ISO 4762 - M5 x 50 Tightening torque $M_A = 8.9 \text{ Nm} \pm 10 \%$	R913000064
Type STW0196	4x ISO 4762 - M6 x 40 - 10.9-fZn-240h-L Tightening torque $M_A = 12.5 \text{ Nm} \pm 10 \%$ or 4x ISO 4762 - M6 x 40 - 10.9 Tightening torque $M_A = 15.5 \text{ Nm} \pm 10 \%$	R913000058

Notice: The tightening torque of the hexagon socket head cap screws refers to the maximum operating pressure!

Subplates	Data sheet
Type STW0195	45052
Type STW0196	45054

Accessories (not included in the scope of delivery)

The following is required for the parameterization with PC:		CANopen	Profibus DP
1	Interface converter (USB)	VT-ZKO-USB/CA-1-1X/V0/0 Mat.no. R901071963	VT-ZKO-USB/P-1-1X/V0/0 Mat.no. R901071962
2	Commissioning software	WINPED Download via www.boschrexroth.de/IAC	
3	Connection cable, 3 m	D-Sub / M12, coding A Mat.no. R900751271	D-Sub / M12, coding B Mat.no. R901078053

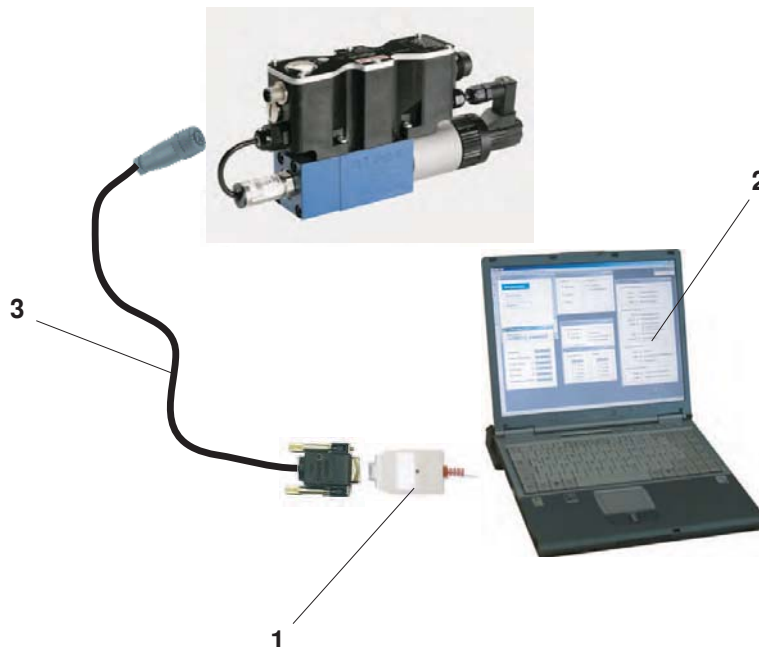

Accessories, port X1 (not included in the scope of delivery)

Mating connector for X1

Mating connector according to DIN EN17520-804 (11-pole + PE), plastic variant

- Mating connector without cable (assembly kit) Material no. **R900884671**
- Mating connector with cable set 2 x 5 m 12-pole Material no. **R900032356**
- Mating connector with cable set 2 x 20 m 12-pole Material no. **R900860399**

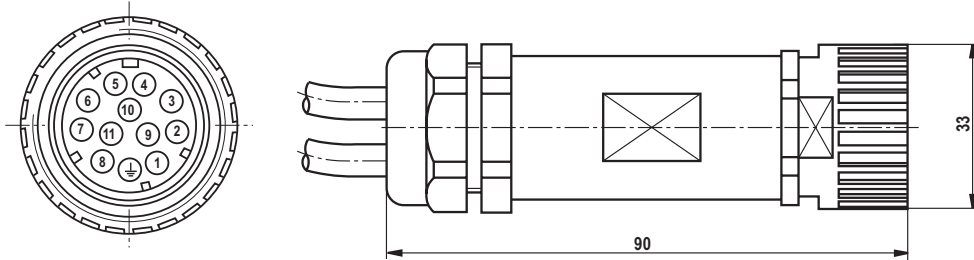

Accessories, CAN bus (A coding) (not included in scope of delivery)

Description	View, dimensions	Pole pattern, order details
X2 Round connector, can be assembled, 5-pole, M12x1 Straight mating connector in metal design.		<p>Mat no.: R901076910 (line diameter 6 - 8 mm)</p>

Accessories, Profibus (B coding) (not included in scope of delivery)

Description	View, dimensions	Pole pattern, order details
X2 Round connector, can be assembled, 5-pole, M12x1 Straight line connector in metal design.		<p>Mat no.: R901075545 (line diameter 6 - 8 mm)</p>
X3 Round connector, can be assembled, 5-pole, M12x1 Straight mating connector in metal design.		<p>Mat no.: R901075550 (line diameter 6 - 8 mm)</p>
M12 protective cap (for mating connector only)		<p>Mat no.: R901075563</p>

Project planning/maintenance instructions/additional information

Product documentation for types STW0195 and STW0196

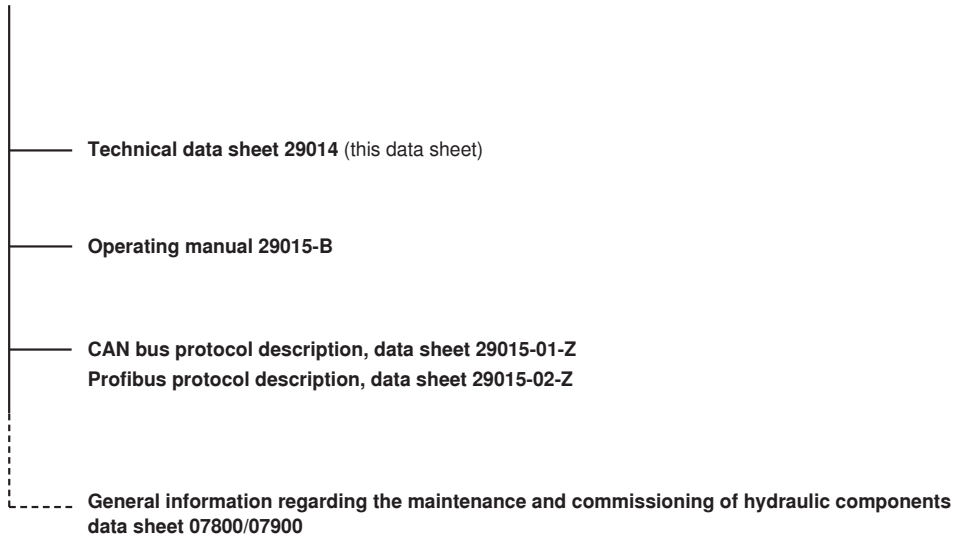

WINPED commissioning software and documentation on the Internet: www.boschrexroth.com/IAC

Maintenance instructions:

- The devices have been tested in the factory and are supplied with default settings.
- Only complete devices can be repaired. Repaired devices are returned with default settings. User-specific settings are not accepted. The machine end-user will have to retransfer the corresponding user parameters.

Notes:

- Connect the valve to the supply voltage only when this is required for the functional sequence of the machine.
- Do not use electrical signals led out of control electronics (e.g. "No error" signal) for switching safety-relevant machine functions (See also EN ISO 13849 "Safety of machinery – safety-related parts of control systems").
- If electro-magnetic interference must be expected, take appropriate measures to ensure the function (depending on the application, e.g. shielding, filtration)!

© This document, as well as the data, specifications and other information set forth in it, are the exclusive property of Bosch Rexroth AG. It may not be reproduced or given to third parties without its consent. The data specified above only serve to describe the product. No statements concerning a certain condition or suitability for a certain application can be derived from our information. The information given does not release the user from the obligation of own judgment and verification. It must be remembered that our products are subject to a natural process of wear and aging.