

Electric Drives
and Controls

Hydraulics

Linear Motion and
Assembly Technologies

Pneumatics

Service

Rexroth
Bosch Group

19" racks

RE 29768/05.08
Replaces: 06.05

1/8

Type VT 19101, VT 19102, VT 19103

Component series 1X

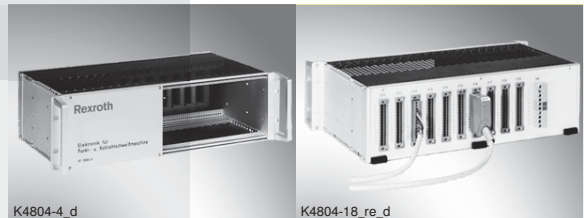

K4804-4_d

19" rack, VT 19101

K4804-18_re_d

19" rack, VT 19101
(view: rear panel with plugs)

Overview of contents

Contents	Page
Features	2
Ordering details	2
Unit dimensions	2 to 5

Unit dimensions: VT 19101-1X (dimensions in mm)

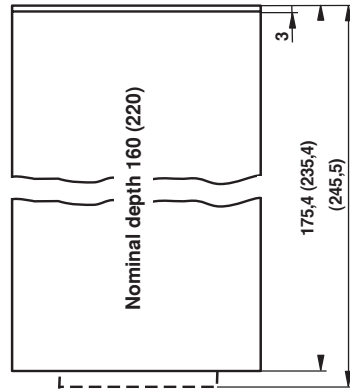

Plug (only possible with a depth of 220)

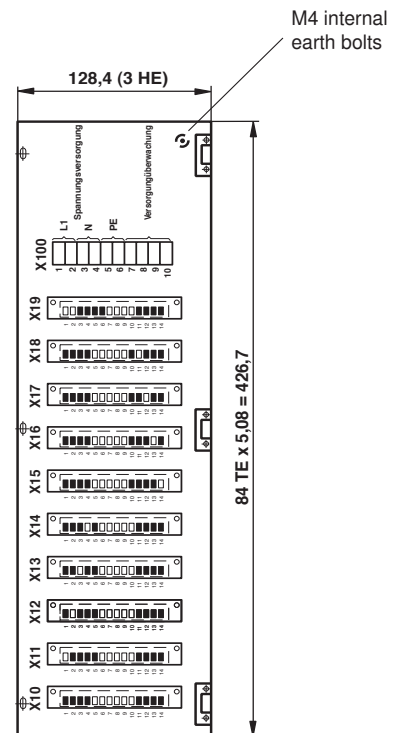
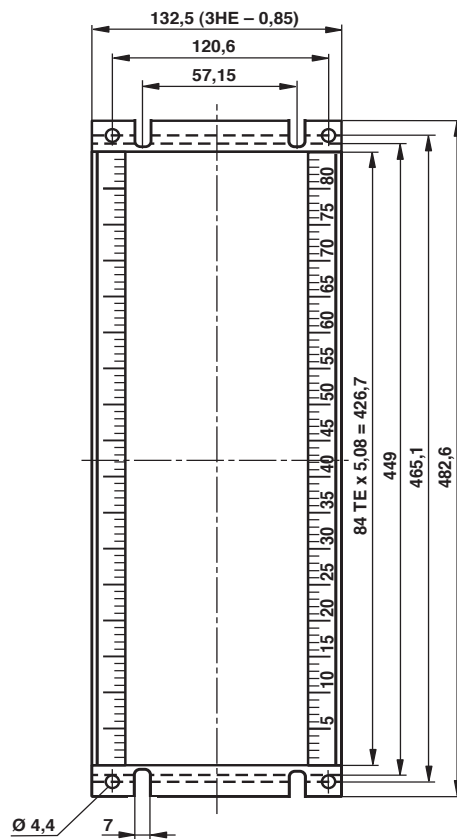

The „u“ numbers indicate the location of the cards within the magazine.
The first digit of the “u” number and the plug number gives the tier location.

Unit dimensions: VT 19102-1X (dimensions in mm)

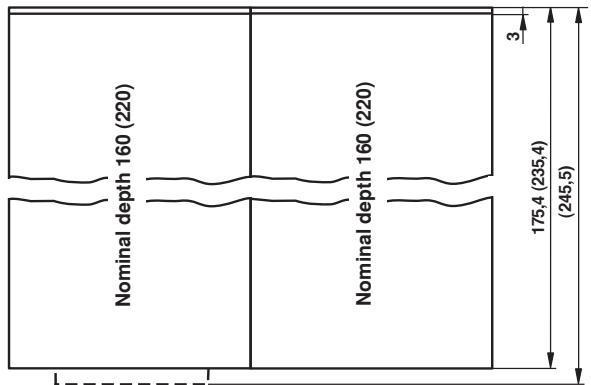

Plug (only possible with a depth of 220)

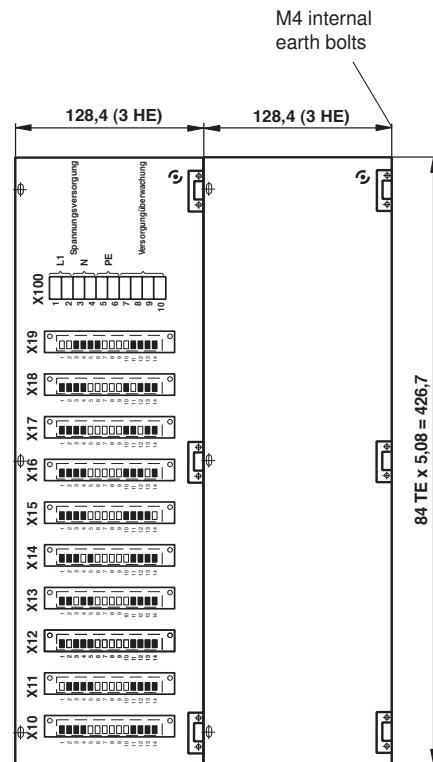
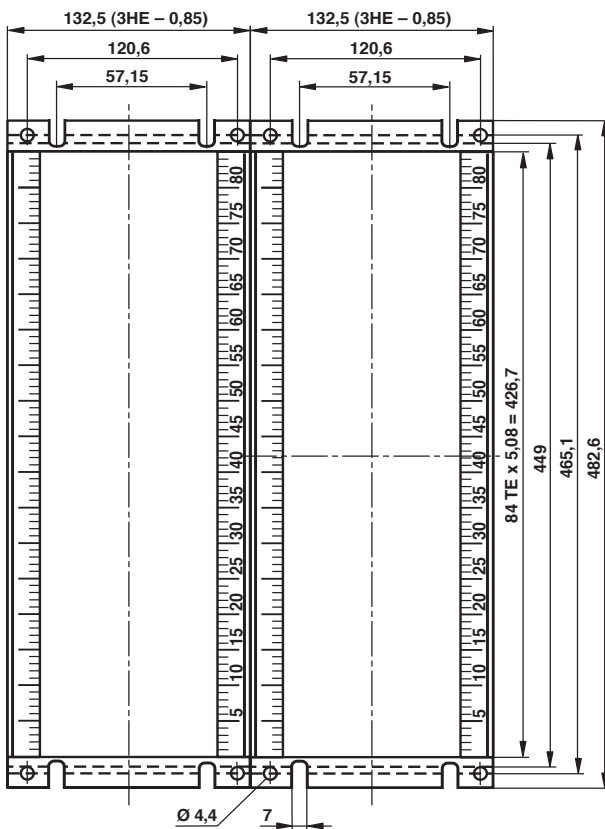

The „u“ numbers indicate the location of the cards within the magazine.
The first digit of the “u” number and the plug number gives the tier location.

Unit dimensions: VT 19103-1X (dimensions in mm)

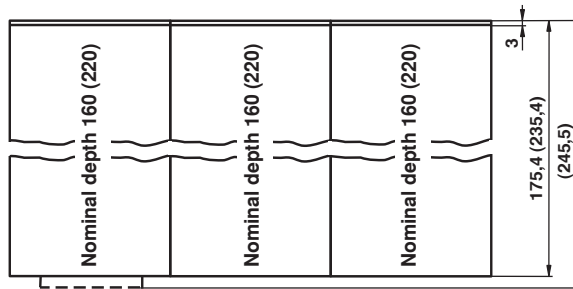

Plug (only possible with a depth of 220)

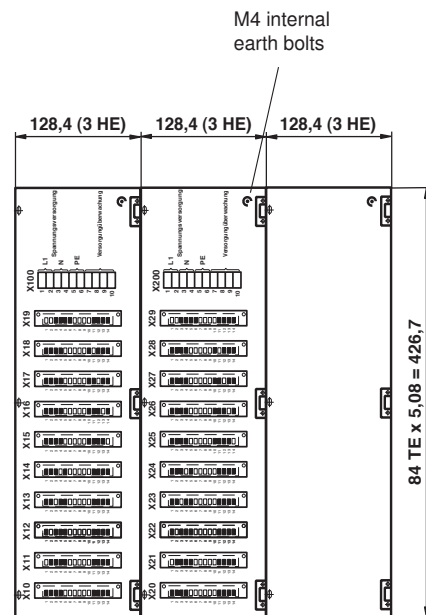
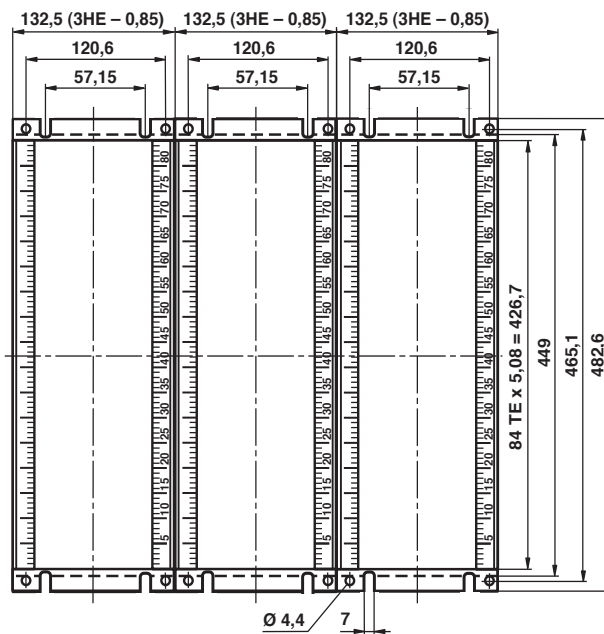

The „u“ numbers indicate the location of the cards within the magazine.
The first digit of the „u“ number and the plug number gives the tier location.

Notes

© This document, as well as the data, specifications and other information set forth in it, are the exclusive property of Bosch Rexroth AG. It may not be reproduced or given to third parties without its consent. The data specified above only serve to describe the product. No statements concerning a certain condition or suitability for a certain application can be derived from our information. The information given does not release the user from the obligation of own judgment and verification. It must be remembered that our products are subject to a natural process of wear and aging.