

The Drive & Control Company

Rexroth
Bosch Group

Radial Piston Hydraulic Motor with Fixed Displacement MR, MRE

RE 15228

Issue: 08.2012

Replaces: 08.2008



- ▶ Sizes 125 to 2100
- ▶ Nominal pressure 250 bar
- ▶ Maximum pressure up to 300 bar
- ▶ Displacement up to 2090 cm³
- ▶ Torque up to 8300 Nm

Features

- ▶ Closely varied displacements
- ▶ Very high starting torque
- ▶ High efficiency, high continuous power
- ▶ Smooth running, even at very low speeds
- ▶ High temperature shock stability
- ▶ Reversible
- ▶ Extremely well suited for control engineering applications
- ▶ Suitable for flame-retardant and biologically degradable fluids
- ▶ Roller bearing for extremely long service life
- ▶ Very low operating noise levels
- ▶ Versions with:
 - Measuring shaft
 - Incremental encoder
- ▶ Line ports via SAE flange or pipe thread
- ▶ Splined shaft or parallel keyed shaft
- ▶ Hollow shaft
- ▶ Version with mounted park brake

Applications

For industrial applications with high power or high torque in either cyclic or continuous operation, with strict requirements regarding controllability and good efficiency at low speeds or broad speed ranges.

Contents

Ordering code	2
Functional description	4
Hydraulic fluid	5
Technical data	7
Bearing service life	8
Case flushing	9
Torque characteristic for MR	10
Torque characteristic for MRE	14
Idling characteristic for MR / MRE	16
Dimensions	18
Dimensions of drive shafts	20
Shaft loading	22
Park brake	23
Incremental encoder	27
Accessories	29
Installation and commissioning notes	31

RE 15228/08.2012, **Bosch Rexroth AG**

2 **MR, MRE** | Ordering code

Ordering code

01	02	-	03	04	05	06	07	08	09
----	----	---	----	----	----	----	----	----	----

Motor type

01	Radial piston hydraulic motor, nominal pressure 250 bar, maximum pressure 300 bar	MR
	Radial piston hydraulic motor, nominal pressure 210 bar, maximum pressure 250 bar	MRE

Size	NG	Displacement [cm ³]	BG	
02 Motor type MR	125	124.7	C	125C
	160	159.7	C	160C
	190	191.6	C	190C
	250	250.9	D	250D
	300	304.1	D	300D
	350	349.5	E	350E
	450	451.6	E	450E
	600	607.9	F	600F
	700	706.9	F	700F
	1100	1125.8	G	1100G
Motor type MRE	1600	1598.4	H	1600H
	1800	1809.6	H	1800H
	330	332.4	D	330D
	500	497.9	E	500E
	800	804.2	F	800F
	1400	1369.5	G	1400G
	2100	2091.2	H	2100H

Drive shafts

03	Splined shaft, DIN ISO 14	N
	Splined shaft, DIN 5480	D
	Parallel keyed shaft	P
	Hollow shaft, internally toothed, DIN 5480	F

Version

04	Standard	1
	For shaft seal F1	2

Speed measuring (2nd drive shaft, see page 26)

05	Without speed measuring	N1
	Cylindrical shaft, Ø8 mm	Q1
	Incremental encoder, monodirectional	M1
	Incremental encoder, bidirectional	B1

Seals

06	NBR seals, suitable for HLP mineral oil according to DIN 51524 Part 2	N1
	FKM seals	V1
	Shaft seal for maximum 15 bar case pressure, NBR seals	F1
	Without shaft seal for brake attachment, NBR seals	U1

Connection flange

07	Without connection flange	N1
	Pipe thread	C1
	SAE flange port	S1
	metric	S1
	UNC	T1

Bosch Rexroth AG, RE 15228/08.2012

Ordering code | **MR, MRE** 3

01	02	-	03	04	05	06	07	08	09
----	----	---	----	----	----	----	----	----	----

Control mode

08	Standard, clockwise rotation, inlet in A; counter-clockwise rotation, inlet in B	N
	Control mode rotated, clockwise rotation, inlet in B; counter-clockwise rotation, inlet in A	S

09	Further details in clear text	
----	-------------------------------	--

Note

Ordering codes for brake, see page 23.

RE 15228/08.2012, **Bosch Rexroth AG**

4 MR, MRE | Functional description

Functional description

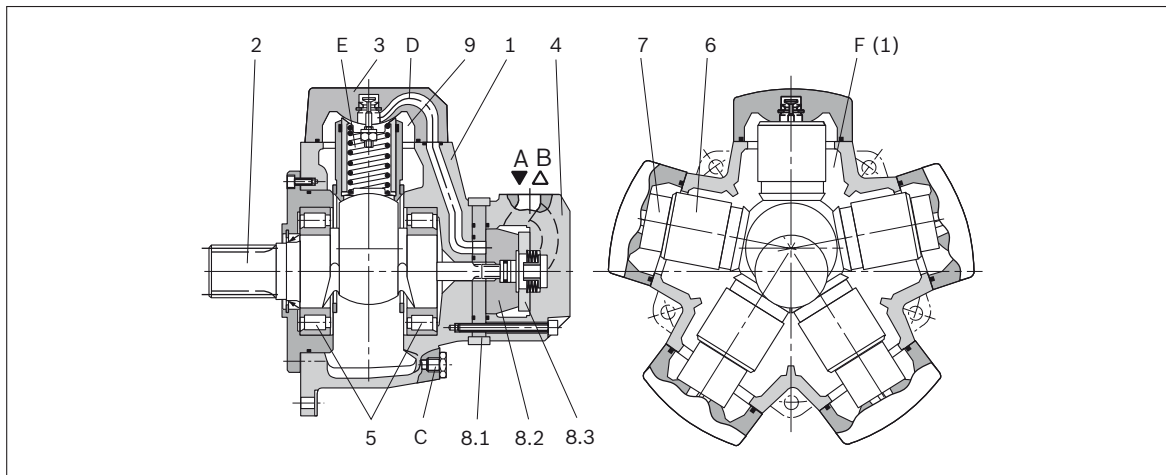

Hydraulic motors of the types MR and MRE are externally pressurized radial piston motors with fixed displacement.

Design

The main components are the housing (1), the eccentric shaft (2), the cover (3), the control case (4), the roller bearing (5), the cylinder (6), the pistons (7) and the control unit (8.1; 8.2; 8.3).

Operating fluid inlet and return

The operating fluid is fed into and from the motor via ports A or B. The cylinder chambers (E) are filled and emptied via the control unit and the ducts (D) in the housing (1).

Rotary group, torque generation

Cylinders and pistons are supported on spherical surfaces on the eccentric shaft and on the cover. This allows the pistons and cylinders to align themselves as the shaft rotates without cross forces. Together with a hydrostatic relief for the pistons and cylinders, this causes minimum friction and very high efficiency. The pressure in the cylinder chambers (E) acts directly on the eccentric shaft. Of the 5 cylinders, 2 or 3 are connected to the inlet side or respectively to the outlet side.

Control unit

The control unit comprises the control plate (8.1) and the distribution valve (8.2). While the control plate is rigidly connected to the housing via pins, the distribution valve rotates at the same speed as the eccentric shaft. Boreholes in the distribution valve are the connection to the control plate and to the piston chambers. Together with the pressure spring and the system pressure, the reaction ring (8.3) is used to adjust the clearance. This achieves a very high temperature shock stability and unchanging performance values for the entire service life.

Leakage

Minor leakage at the pistons and control unit in housing F (1) must be drained via the case drain port (C).

▼ Symbols

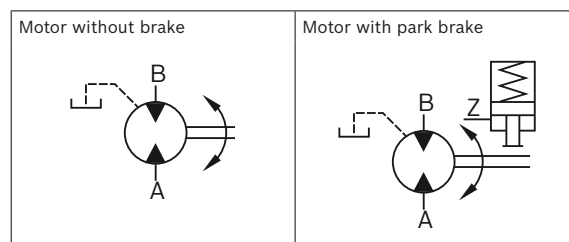

Hydraulic fluid

HLP mineral oil according to DIN 51524 Part 2

Prior to project planning, please refer to the detailed information in our data sheet RE 90220 concerning the choice of hydraulic fluid.

Please contact us if the unit is to be operated with HFB or HFC hydraulic fluid or with biologically degradable hydraulic fluid.

FKM seals are required if the unit is to be operated with phosphoric acid ester (HFD).

Operating viscosity range

We recommend you to choose the operating viscosity (at operating temperature) in the optimum range for efficiency and useful life of

- ▶ v_{opt} = optimum operating viscosity 30...50 mm²/s relative to the circuit temperature in a closed circuit, the reservoir temperature in an open circuit, and the temperature in the motor housing (case drain temperature).

Limits of viscosity range

The following values for viscosity apply in extreme cases:

- ▶ v_{min} = 10 mm²/s in case of emergency, short-term
- ▶ v_{min} = 18 mm²/s with reduced performance data
- ▶ v_{max} = 1000 mm²/s short-term for cold start

Details regarding the choice of hydraulic fluid

The correct choice of hydraulic fluid requires knowledge of the operating temperature in relation to the ambient temperature. In a closed circuit, the circuit temperature; in an open circuit, the reservoir temperature. In order to achieve maximum continuous power values, the hydraulic fluid viscosity has to be in the range of the optimum operating viscosity, relative to both the inlet temperature and the case drain temperature.

Example: At an ambient temperature of X °C, the operating temperature (closed circuit: circuit temperature, open circuit: reservoir temperature) will settle to 50 °C. In the optimum operating viscosity range (v_{opt} ; shaded area), this corresponds to the viscosity classes VG 46 or VG 68; to be selected: VG 68.

Note

The case drain temperature, which is affected by pressure and speed, is always higher than the circuit temperature or reservoir temperature. At no point of the component may the temperature be higher than 80 °C, however.

If these conditions cannot be maintained at extreme operating parameters or due to a high ambient temperature, our advice is to flush the case, even outside the specified range (see diagrams on pages 10 to 15). Consult us if necessary.

▼ Selection diagram

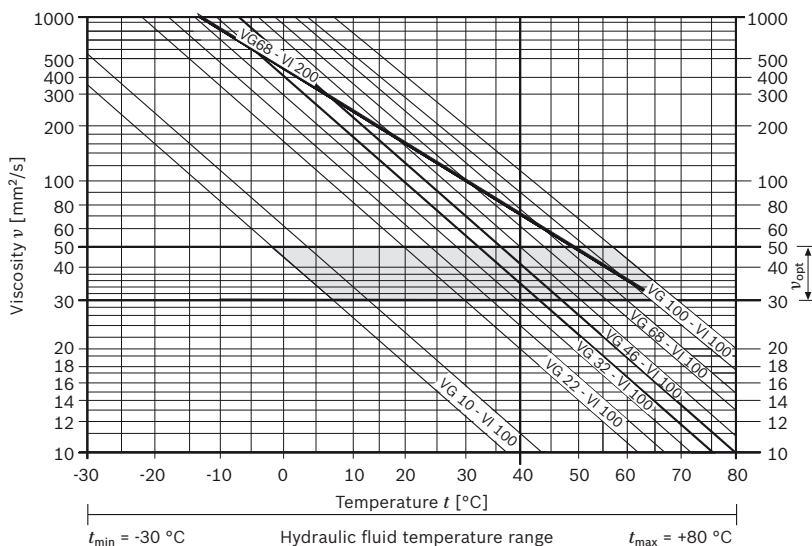

Viscosity range according to DIN ISO 3448

6 MR, MRE | Hydraulic fluid

Filtration of the hydraulic fluid

The finer the filtration, the higher the cleanliness level of the hydraulic fluid and the longer the service life of the radial piston motor.

To ensure functional reliability of the radial piston motor, the hydraulic fluid must have a cleanliness level of at least:

- ▶ 6 according to SAE, ASTM, AIA
- ▶ 19/16/13 according to ISO 4406

Case drain pressure

The lower the speed and the case drain pressure, the longer the service life of the shaft seal. The limit value for the permissible case pressure is

- ▶ $p_{\max} = 5$ bar

regardless of motor speed.

For higher case pressures, a shaft seal suitable for up to $p_{\max} = 15$ bar may be installed (ordering code F).

For further information about flushing the case, please refer to page 9.

Shaft seal FKM

Some hydraulic fluids require the use of FKM seals and shaft seals (type: HFD...). We recommend the use of FKM shaft seals at high operating temperatures in order to prolong the service life.

Technical data

Table of values

Size (MR)		NG	125	160	190	250	300	350
Displacement	<i>V</i>	cm ³	124.7	159.7	191.6	250.9	304.1	349.5
Moment of inertia	<i>J</i>	kg cm ²	56.88	57.5	58.2	60.8	65.43	225.9
Specific torque		Nm/bar	2.0	2.54	3.05	4.00	4.80	5.57
Minimum starting torque/ theoretical torque		%	90	90	90	90	90	90
Inlet pressure, maximum	continuous	<i>p</i> bar	250	250	250	250	250	250
	intermittent	<i>p</i> bar	300	300	300	300	300	300
	peak	<i>p</i> bar	420	420	420	420	420	420
Accumulated pressure, maximum in port A + B, intermittent	<i>p</i>	bar	400	400	400	400	400	400
Case drain pressure, maximum	<i>p</i>	bar	5 (15 bar for version ...F...), please refer to page 6					
Speed range	<i>n</i>	rpm	1-900	1-900	1-850	1-800	1-750	1-640
Continuous power, maximum	without flushing	<i>P</i> kW	17	20	24	32	35	41
	with flushing	<i>P</i> kW	25	30	36	48	53	62
Mass	<i>m</i>	kg	46	46	46	50	50	77
Size (MR)		NG	450	600	700	1100	1600	1800
Displacement	<i>V</i>	cm ³	451.6	607.9	706.9	1125.8	1598.4	1809.6
Moment of inertia	<i>J</i>	kg cm ²	229.3	265.07	358.4	451.5	666.43	854.1
Specific torque		Nm/bar	7.20	9.70	11.26	17.93	25.40	28.82
Minimum starting torque/ theoretical torque		%	90	90	90	91	90	90
Inlet pressure, maximum	continuous	<i>p</i> bar	250	250	250	250	250	250
	intermittent	<i>p</i> bar	300	300	300	300	300	300
	peak	<i>p</i> bar	420	420	420	420	420	420
Accumulated pressure, maximum in port A + B, intermittent	<i>p</i>	bar	400	400	400	400	400	400
Case drain pressure, maximum	<i>p</i>	bar	5 (15 bar for version ...F...), please refer to page 6					
Speed range	<i>n</i>	rpm	1-600	1-520	1-500	0.5-330	0.5-260	0.5-250
Continuous power, maximum	without flushing	<i>P</i> kW	46	56	65	77	96	103
	with flushing	<i>P</i> kW	75	84	97	119	144	153
Mass	<i>m</i>	kg	77	97	97	140	209	209
Size (MRE)		NG	330	500	800	1400	2100	
Displacement	<i>V</i>	cm ³	332.4	497.9	804.2	1369.5	2091.2	
Moment of inertia	<i>J</i>	kg cm ²	65.50	229.8	358.4	451.5	854.1	
Specific torque		Nm/bar	5.30	7.93	12.81	21.81	33.30	
Minimum starting torque/ theoretical torque		%	90	90	90	92	91	
Inlet pressure, maximum	continuous	<i>p</i> bar	210	210	210	210	210	
	intermittent	<i>p</i> bar	250	250	250	250	250	
	peak	<i>p</i> bar	350	350	350	350	350	
Accumulated pressure, maximum in port A + B, intermittent	<i>p</i>	bar	400	400	400	400	400	
Case drain pressure, maximum	<i>p</i>	bar	5 (15 bar for version ...F...), please refer to page 6					
Speed range	<i>n</i>	rpm	1-750	1-600	1-450	0.5-280	0.5-250	
Continuous power, maximum	without flushing	<i>P</i> kW	32	46	65	77	100	
	with flushing	<i>P</i> kW	49	70	93	102	148	
Mass	<i>m</i>	kg	50	77	97	145	221	

Note

- ▶ All technical data at $v = 36 \text{ mm}^2/\text{s}$, $\theta = 45 \text{ }^\circ\text{C}$, $p_{\text{outlet}} = \text{depressurized}$
- ▶ Please contact us if the unit is to be used outside the specified values

8 **MR, MRE** | Bearing service life

Bearing service life

For a detailed calculation of the bearing service life, please consult us regarding the application data: pressure, speed, viscosity, external load on the drive shaft end.

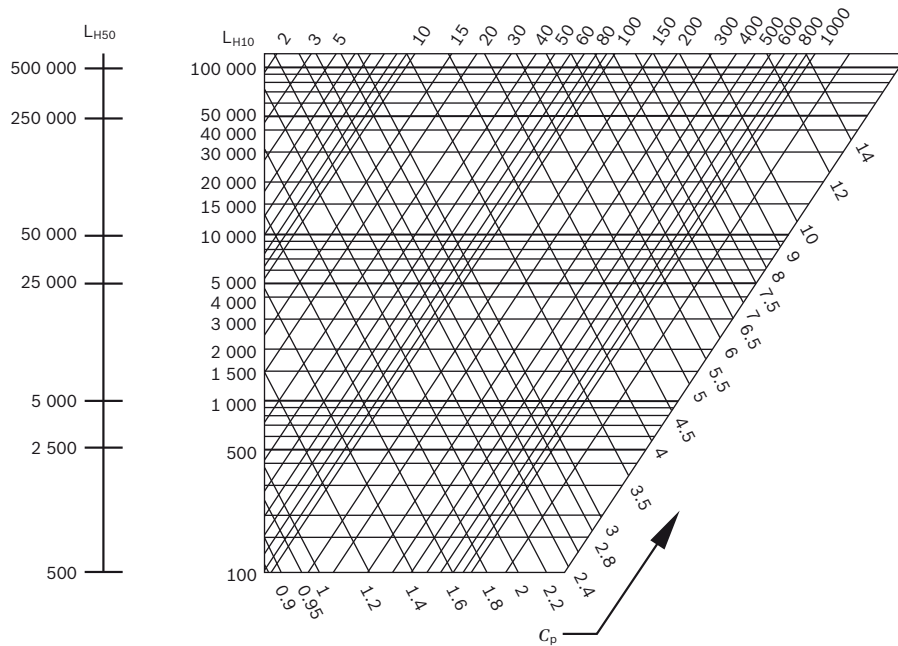

Key		
$C_p = \frac{K}{p}$	C_p	Load coefficient
	K	Service life coefficient
	p	Operating pressure (motor) [bar]

Note
L_{H10} is the nominal service life that 90 % of all bearings exceed (values for 36 mm²/s and 45 °C). The mean average service life of all bearings L_{H50} is 5 x L_{H10}

MR	125	160	190	250	300	350	450	600	700	1100	1600	1800
K	950	950	950	950	950	1126	1126	920	920	844	835	835

MRE	330	500	800	1400	2100
K	850	1021	808	693	722

Case flushing

Case flushing is necessary to achieve maximum continuous power values (see diagrams on pages 10 to 15).

Under certain conditions and to maintain the recommended operating viscosity of 30 to 50 mm²/s in the housing, it may be necessary to flush the motor even outside the specified range (see page 5). A simple way of checking this is to measure the surface temperature $\theta_A + 3$ °C.

At high continuous power, case flushing is also recommended outside the specified range. Maximum permissible case pressure: 5 bar (cf. page 6). Please consult the Technical Product Management department regarding the choice of an appropriate throttle diameter.

Flushing fluid volume

Type	NG	qv [L/min]
MR	125, 130, 160, 190, 250, 300	6
MR / MRE	350, 450, 500	8
MR / MRE	600, 700, 800, 1100, 1400	10
MR / MRE	1600, 1800, 2100	15

Switching example for single direction of rotation

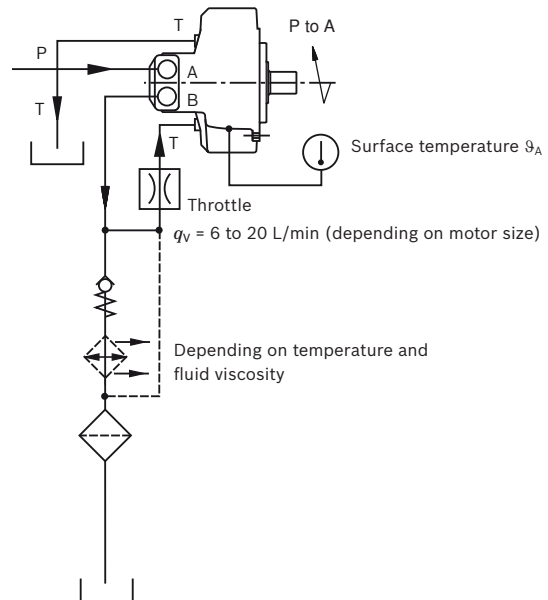

Switching example for alternating direction of rotation

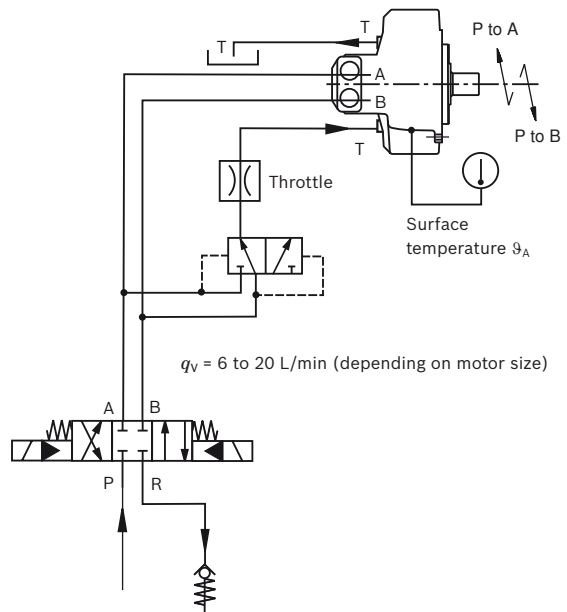

10 MR, MRE | Torque characteristic for MR

Torque characteristic for MR

▼ MR125

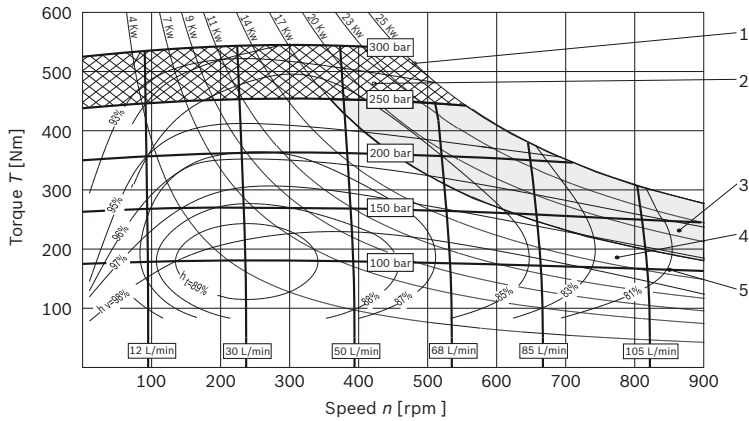

Key	
1	Output power
2	Permissible for intermittent operation
3	Permissible for continuous operation with flushing
4	Permissible for continuous operation
5	Inlet pressure
η_t	Total efficiency
η_v	Volumetric efficiency

▼ MR160

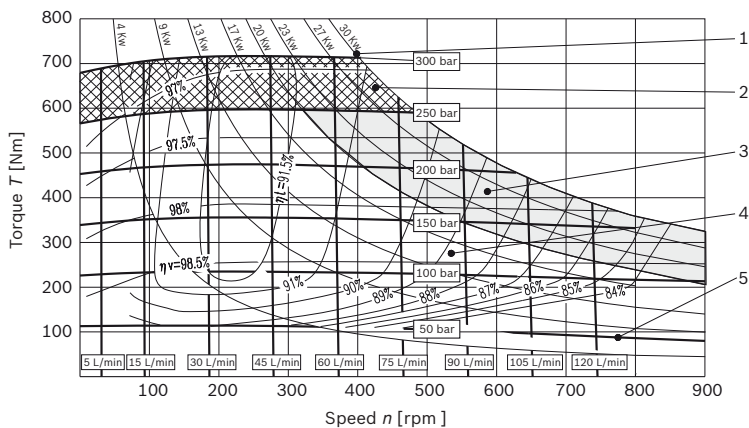

▼ MR190

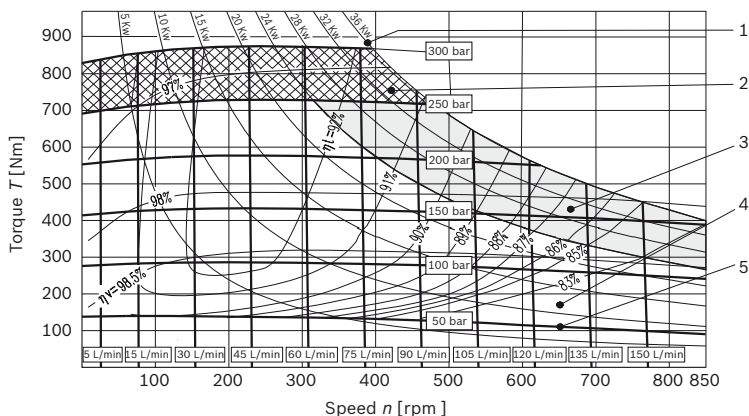

Note

Characteristic (mean value) measured at $v = 36 \text{ mm}^2/\text{s}$; $\theta = 45 \text{ }^\circ\text{C}$; $p_{\text{output}} = \text{depressurized}$

Bosch Rexroth AG, RE 15228/08.2012

▼ **MR250**

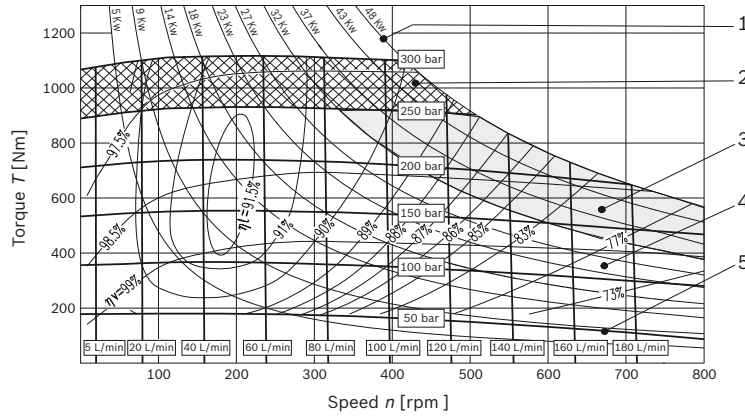

Key

- | | |
|----------|--|
| 1 | Output power |
| 2 | Permissible for intermittent operation |
| 3 | Permissible for continuous operation with flushing |
| 4 | Permissible for continuous operation |
| 5 | Inlet pressure |
| η_t | Total efficiency |
| η_v | Volumetric efficiency |

▼ **MR300**

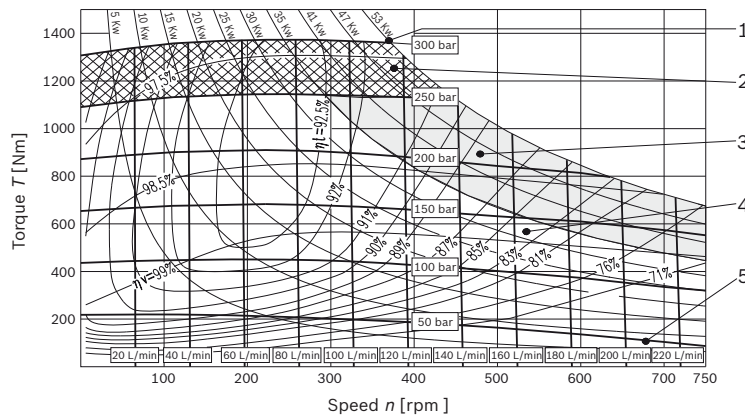

▼ **MR350**

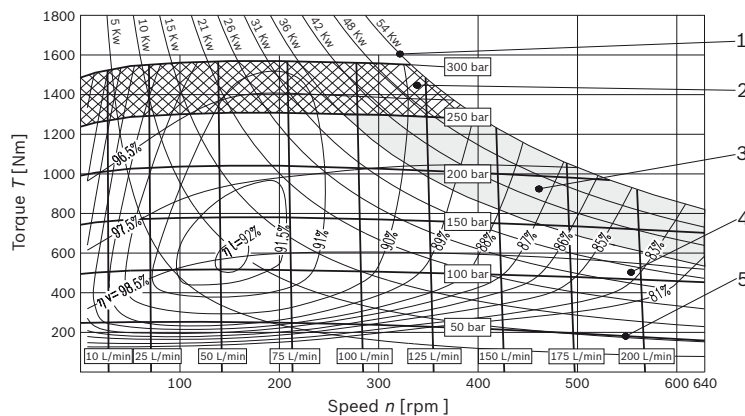

Note

Characteristic (mean value) measured at $v = 36 \text{ mm}^2/\text{s}$; $\theta = 45 \text{ }^\circ\text{C}$; $p_{\text{output}} = \text{depressurized}$

12 MR, MRE | Torque characteristic for MR

▼ MR450

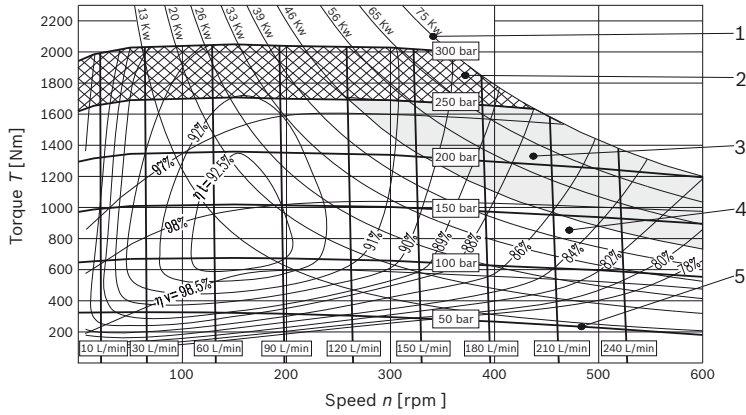

Key	
1	Output power
2	Permissible for intermittent operation
3	Permissible for continuous operation with flushing
4	Permissible for continuous operation
5	Inlet pressure
η_t	Total efficiency
η_v	Volumetric efficiency

▼ MR600

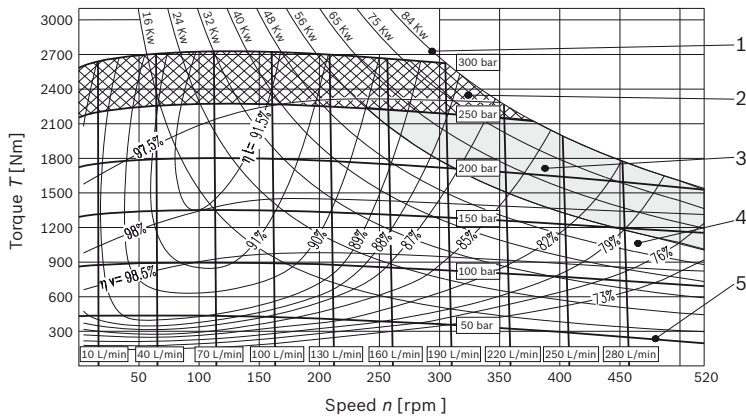

▼ MR700

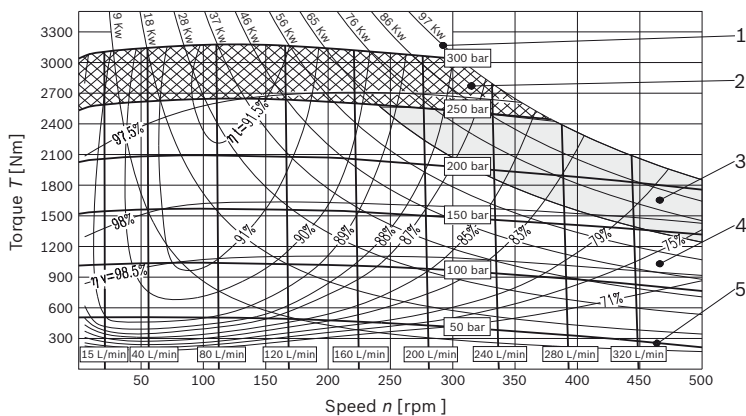

Note

Characteristic (mean value) measured at $v = 36 \text{ mm}^2/\text{s}$; $\theta = 45 \text{ }^\circ\text{C}$; $p_{\text{output}} = \text{depressurized}$

Bosch Rexroth AG, RE 15228/08.2012

▼ **MR1100**

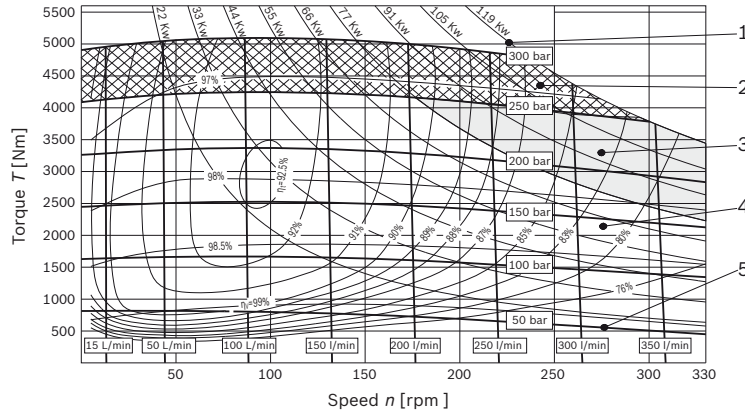

Key	
1	Output power
2	Permissible for intermittent operation
3	Permissible for continuous operation with flushing
4	Permissible for continuous operation
5	Inlet pressure
η_t	Total efficiency
η_v	Volumetric efficiency

▼ **MR1600**

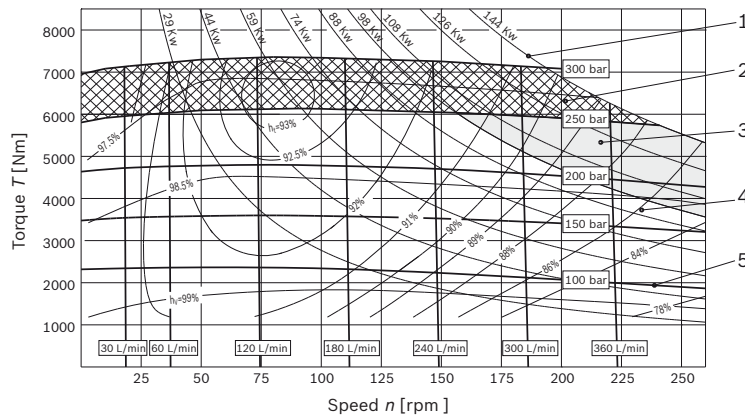

▼ **MR1800**

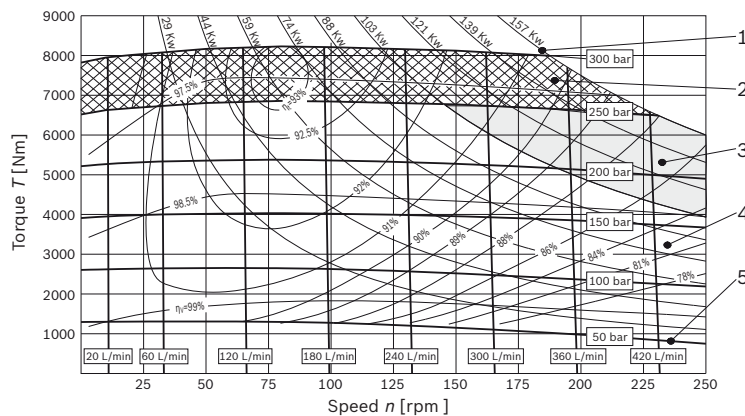

Note

Characteristic (mean value) measured at $v = 36 \text{ mm}^2/\text{s}$; $\theta = 45 \text{ }^\circ\text{C}$; $p_{\text{output}} = \text{depressurized}$

14 MR, MRE | Torque characteristic for MRE

Torque characteristic for MRE

▼ MRE330

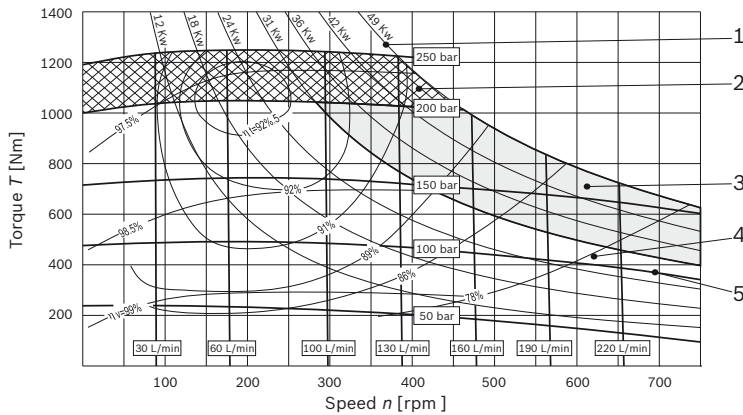

Key	
1	Output power
2	Permissible for intermittent operation
3	Permissible for continuous operation with flushing
4	Permissible for continuous operation
5	Inlet pressure
η_t	Total efficiency
η_v	Volumetric efficiency

▼ MRE500

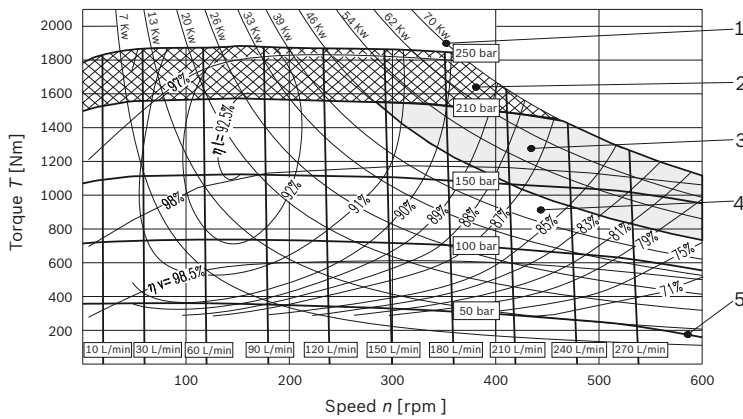

▼ MRE800

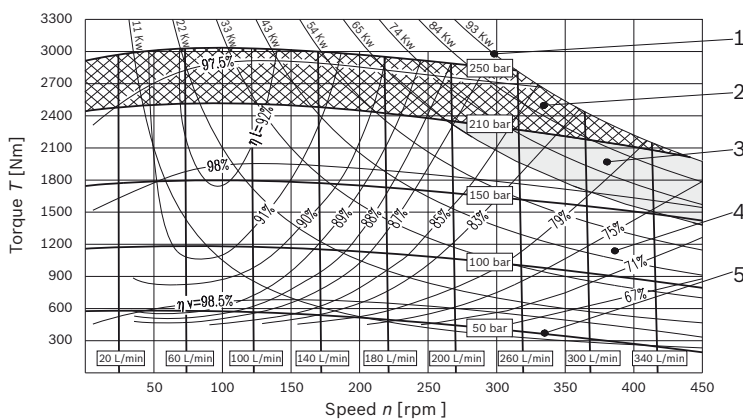

Note

Characteristic (mean value) measured at $v = 36 \text{ mm}^2/\text{s}$; $\theta = 45 \text{ }^\circ\text{C}$; $p_{\text{output}} = \text{depressurized}$

Bosch Rexroth AG, RE 15228/08.2012

Torque characteristic for MRE | **MR, MRE** 15

▼ **MRE1400**

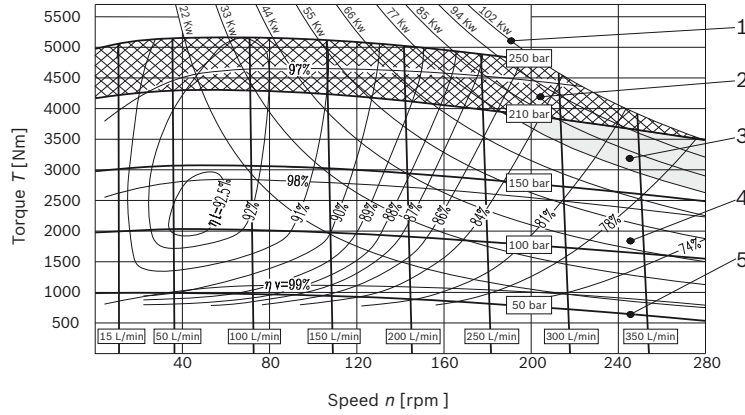

Key	
1	Output power
2	Permissible for intermittent operation
3	Permissible for continuous operation with flushing
4	Permissible for continuous operation
5	Inlet pressure
η_t	Total efficiency
η_v	Volumetric efficiency

▼ **MRE2100**

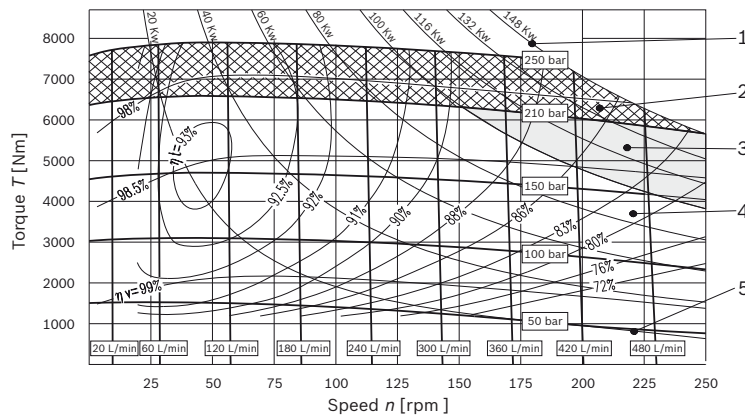

Note

Characteristic (mean value) measured at $v = 36 \text{ mm}^2/\text{s}$; $\theta = 45 \text{ }^\circ\text{C}$; $p_{\text{output}} = \text{depressurized}$

RE 15228/08.2012, **Bosch Rexroth AG**

16 **MR, MRE** | Idling characteristic for MR / MRE

Idling characteristic for MR / MRE

Minimum necessary differential pressure Δp at idle (shaft without load)

▼ MR125 to 300 MRE 330

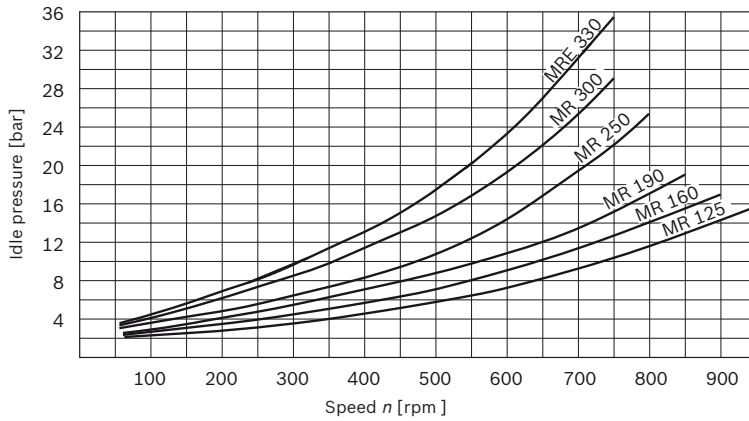

▼ MR350 to 700 MRE 500, 800

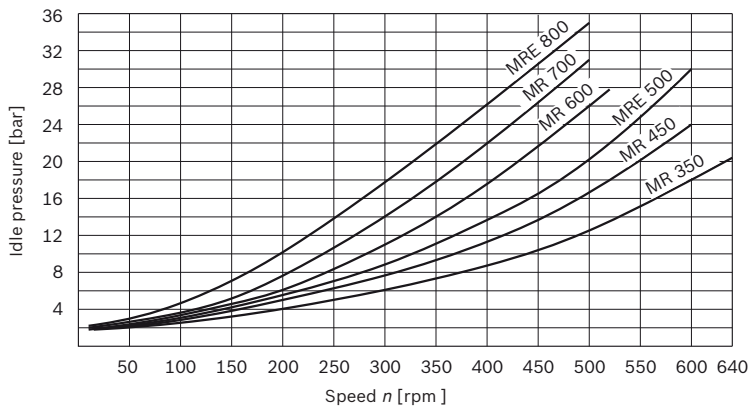

▼ MR1100 to 1800 MRE 1400, 2100

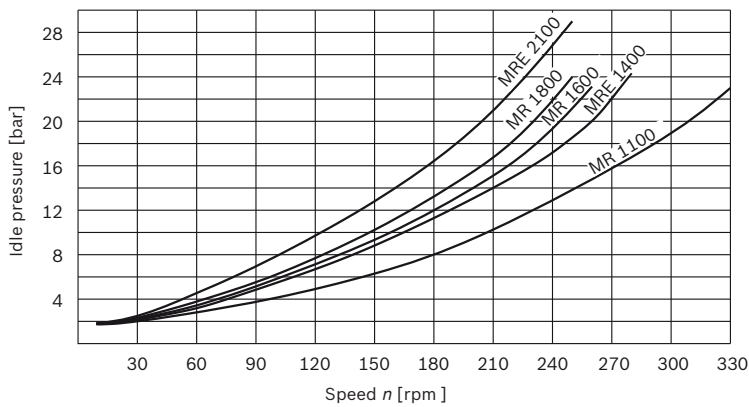

Bosch Rexroth AG, RE 15228/08.2012

Minimum necessary boost pressure in brake operation (pump mode)

▼ **MR125 to 300**
MRE 330

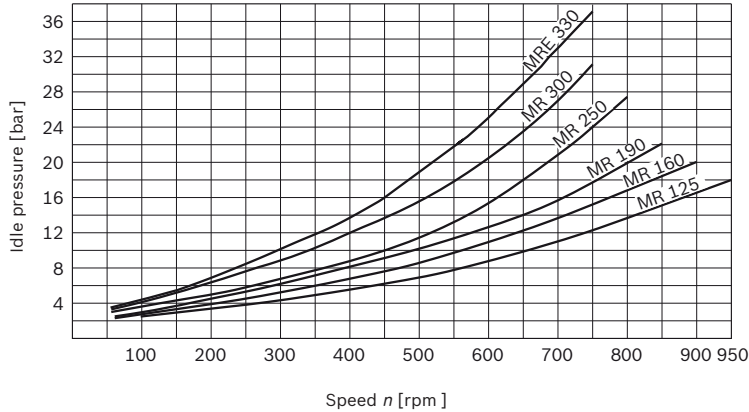

▼ **MR350 to 700**
MRE 500, 800

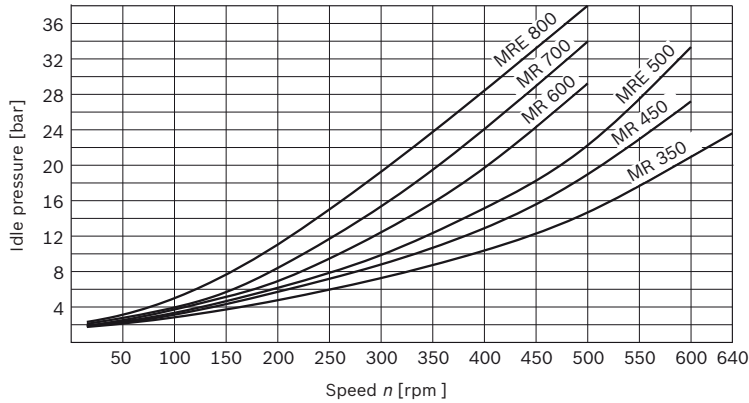

▼ **MR1100 to 1800**
MRE 1400, 2100

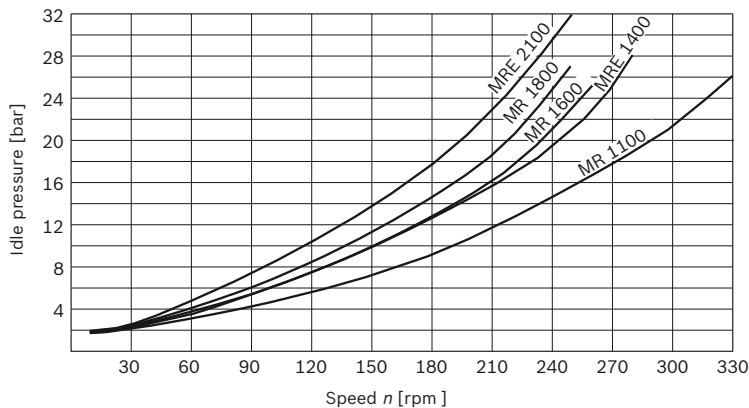

18 MR, MRE | Dimensions

Dimensions

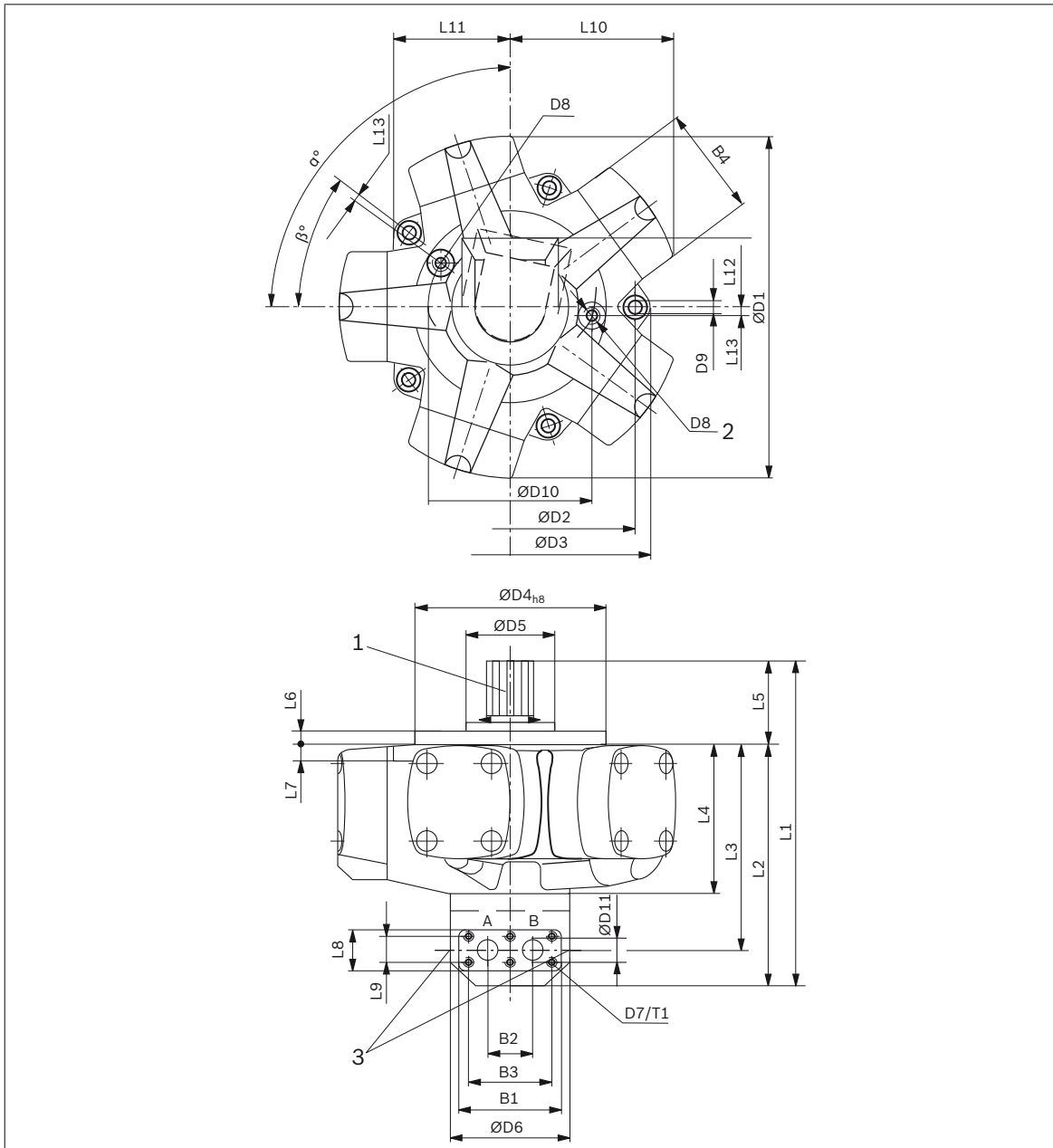

Direction of rotation (viewed on drive shaft)	Inlet to port	Ordering code
clockwise	A	N
counter-clockwise	B	
clockwise	B	S
counter-clockwise	A	

- 1 Splined shaft with flank centering
(for dimensions, see page 20)
Ordering code "N"
- 2 Case drain port pipe thread "G" according to
DIN EN ISO 228-1
- 3 G1/4 gauge port according to DIN EN ISO 228-1

Bosch Rexroth AG, RE 15228/08.2012

Installation dimensions in mm

Motor type	MR125, 160, 190	MR250, 300 MRE330	MR350, 450 MRE500	MR600, 700 MRE800	MR1100 MRE1400	MR1600, 1800 MRE2100
L1	309	323	376	400	458	506
L2	242	242	279	299	341	374
L3	204	204	235	255	293	326
L4	145	145	167	187	203	236
L5	67	81	97	101	117	132
L6	14	15	15	15	20	21
L7	16	16	18	20	22	24
L8	54	54	70.4	70.4	82	82
L9	34	34	40	40	50	50
L10	147.5	153.5	174.5	192	223	264
L11	103	119	130	143	165	197
L12	72	72	84	84	105	105
L13	6.5	7.5	9.5	8	9	11
B1	120	120	142	142	162	162
B2	50	50	60	60	73	73
B3	100	100	120	120	136	136
B4	100	100	119	133	148	168
ØD1	313.2	328	368	405	470	558
ØD2	225	232	266	290	330	380
ØD3	249	256	296	320	367	423
ØD4 _{h8}	160	175	190	220	250	290
ØD5	-	90	96	102	120	148
ØD6	129	129	156	156	172	172
D7	M8	M8	M10	M10	M12	M12
T1	15	15	18	18	21	21
D8	G3/8	G3/8	G3/8	G3/8	G1/2	G1/2
D9	11	11	13	13	15	17
ØD10	160	162	194	207	228	266
ØD11	20	20	25	25	31	31
α°	90	90	90	90	104	90
β°	36	36	36	36	36	36

Installation dimensions in mm

RE 15228/08.2012, **Bosch Rexroth AG**

20 **MR, MRE** | Dimensions of drive shafts

Dimensions of drive shafts

Version N

According to DIN ISO 14

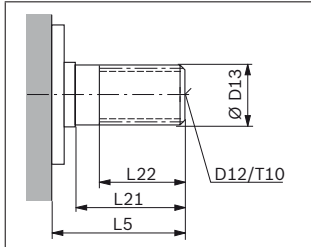

Motor type	MR125, 160, 190	MR250, 300 MRE330	MR350, 450 MRE500	MR600, 700 MRE800	MR1100 MRE1400	MR1600, 1800 MRE2100
L5	67	81	97	101	117	132
L21	50	60	74	78	88	100
L22	35.5	46	56.5	62	69	79
D12	M12	M12	M12	M12	M12	M12
T10	20	25	25	25	25	25
ØD13	B8x32x38	B8x42x48	B8x46x54	B8x52x60	B8x62x72	B10x72x82

Version D

According to DIN 5480

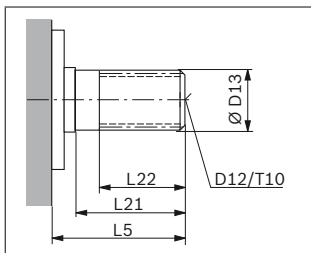

Motor type	MR125, 160, 190	MR250, 300 MRE330	MR350, 450 MRE500	MR600, 700 MRE800	MR1100 MRE1400	MR1600, 1800 MRE2100
L5	67	81	97	101	117	132
L21	50	60	74	78	88	100
L22	35.5	46	60	62	72	80
D12	M12	M12	M12	M12	M12	M12
T10	20	25	25	25	25	25
ØD13	W38x2x18-8e	W48x2x22-8e	W55x3x17-8e	W60x3x18-8e	W70x3x22-8e	W80x3x25-8e

Version F

According to DIN 5480

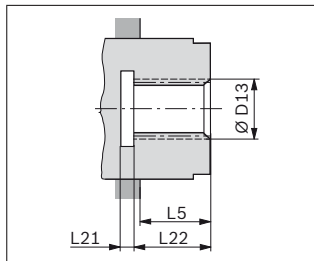

Motor type	MR125, 160, 190	MR250, 300 MRE330	MR350, 450 MRE500	MR600, 700 MRE800	MR1100 MRE1400	MR1600, 1800 MRE2100
L5	14	27	28	28	38	47
L21	5	5	5	5	8	8
L22	28	36	38	44	50	57
ØD13	N35x2x16-9H	N40x2x18-9H	N47x2x22-9H	N55x3x17-9H	N65x3x20-9H	N75x3x24-9H

Version P

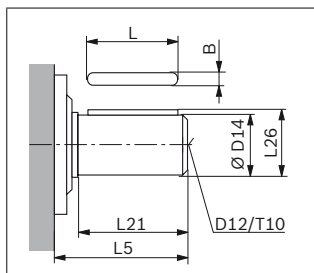

Motor type	MR125, 160, 190	MR250, 300 MRE330	MR350, 450 MRE500	MR600, 700 MRE800	MR1100 MRE1400	MR1600, 1800 MRE2100
L5	67	81	97	101	117	132
L21	50	60	74	78	88	100
L26	43	53.8	59	64	76.5	85
D12	M12	M12	M12	M12	M12	M12
T10	20	25	25	25	25	25
ØD14	40 _{k6}	50 _{k6}	55 _{k6}	60 _{k6}	70 _{k6}	80 _{k6}
Key L x B	45 x 12	56 x 14	70 x 16	70 x 18	80 x 20	90 x 22
Transmittable torque	496	897	1413	2030	2690	4020

Note

Please consult the Technical Product Management department if higher torques are to be transmitted.

22 MR, MRE | Shaft loading

Shaft loading

Maximum permissible radial force F_{max} [kN] in middle of shaft, based on L_{H10} 5000 hours

Motor type		MR					MRE						
		125, 160, 190	250, 300	350, 450	600, 700	1100	1600, 1800	330	500	800	1400	2100	
At speed	n [rpm]	275	250	225	200	150	125	250	225	200	140	120	
and inlet pressure													
	Dynamic load ¹⁾	[kN]	22.5	28.0	35.0	43.0	54.0	68.0	28.0	35.0	43.0	54.0	68.0
	200 bar	[kN]	5.0	5.6	14.5	15.0	18.5	26.2	4.5	12.4	8.5	8.6	12.5
	150 bar	[kN]	9.9	9.9	18.4	22.5	28.5	40.6	8.5	17.3	19.8	24.0	35.6
	100 bar	[kN]	12.9	12.9	21.2	27.3	35.2	50.0	11.9	20.8	26.3	33.6	48.3

1) Higher values are permissible, depending on the load state.

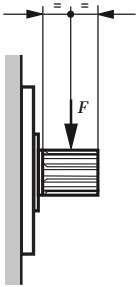

Park brake

Ordering code

		01		02		03		04		05
Multiple disk brake	-		-							

Frame size

01	See table below	B190C	B300D	B450E	B700F	B1100G	B1800H
----	-----------------	--------------	--------------	--------------	--------------	---------------	---------------

Output drive shaft¹⁾

02	Splined shaft, DIN ISO 14	N1
	Splined shaft, DIN 5480	D1

Input drive shaft

03	Mounted on motor	with splined shaft according to DIN ISO 14	N1
		with splined shaft according to DIN 5480	D1

Seals

04	NBR seals, suitable for HLP mineral oil according to DIN 51524 Part 2	N1
	FKM seals	V1

05	Further details in clear text	
----	-------------------------------	--

Technical data

Please contact us if the unit is to be used outside the specified values!

Brake type			B190C	B300D	B450E	B700F	B1100G	B1800H
Static braking torque	<i>T</i>	Nm	1250	1800	2650	4000	6200	11400
Dynamic braking torque ²⁾	<i>T</i>	Nm	650	1200	1450	2200	4200	6250
Release pressure	<i>p</i>	bar	28	28	27	27	27	30
Maximum operating pressure	<i>p</i>	bar	420	420	420	420	420	420
Moment of inertia	<i>J</i>	kg x m ²	0.0047	0.0062	0.029	0.043	0.061	0.20
Weight	<i>m</i>	kg	32	39	54	74	100	158
Assignment to motor type MR / MRE			125	250	350	600	1100	1600
			160	300	450	700	1400	1800
			190	330	500	800		2100

1) Dimensions as motor

2) The brake may only be briefly dynamically loaded (e.g. for an emergency stop).

24 **MR, MRE** | Park brake

Dimensions

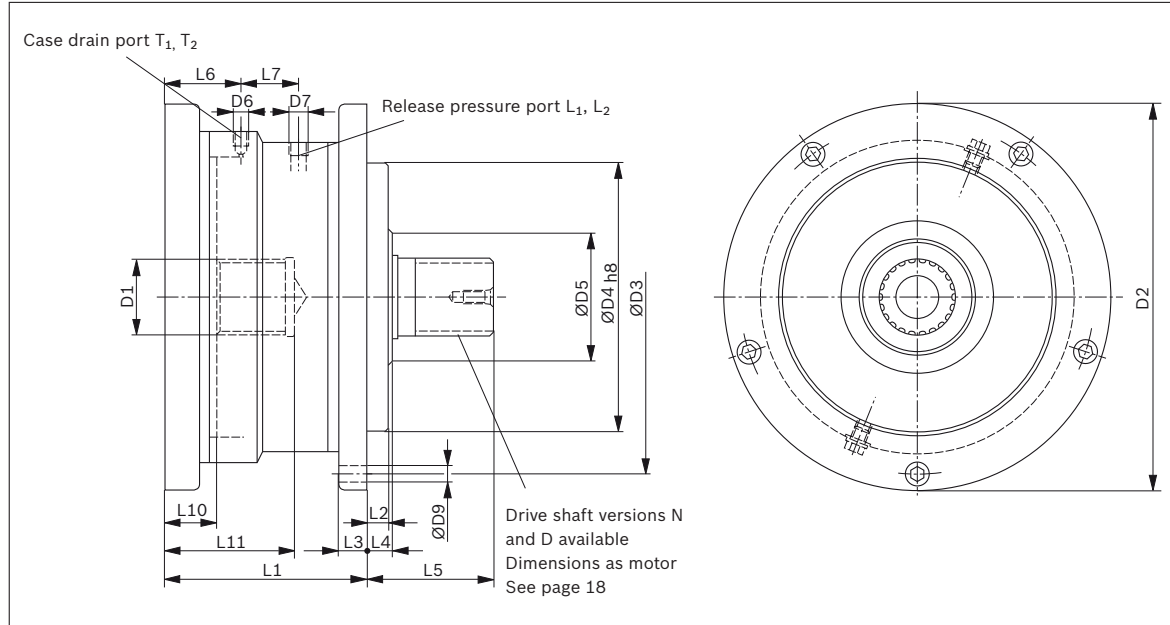

Park brake	B190C	B300D	B450E	B700F	B1100G	B1800H
L1	135	135	172	172	193	211
L2	-	-	-	-	20	16
L3	15.5	14.5	28	28	31	28
L4	14	15	15	15	25	29.5
L5	67	81	97	101	117	132
L6	52.5	53.5	57	57	73	69
L7	30.5	30.5	40	40	51	56
L10	N1 35 D1 37	37	40	39	50	50
L11	N1 75 D1 76	87	99	104	119	131
ØD2	250	256	320	320	-	423
ØD3	225	232	266	290	330	380
ØD4h8	160	175	190	220	250	290
ØD5	-	-	-	-	120	148
ØD6	G1/4	G1/4	G3/8	G3/8	G1/2	G1/2
ØD7	G1/4	G1/4	G1/4	G1/4	G1/4	G1/4
ØD9	11	11	13	13	15	17

Location of case drain and release pressure ports

B190C

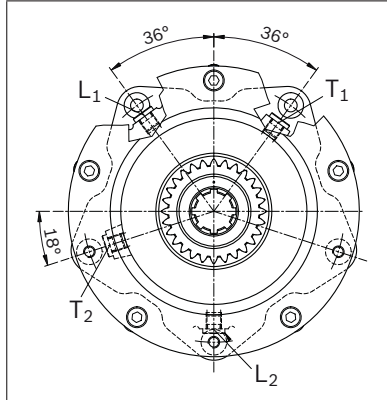

B300D

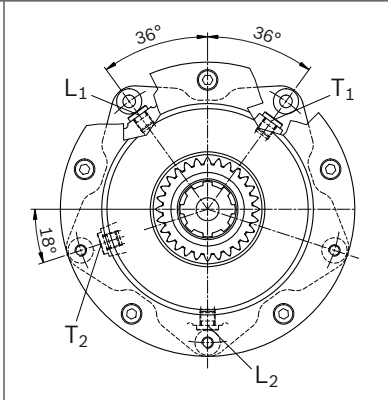

B450E

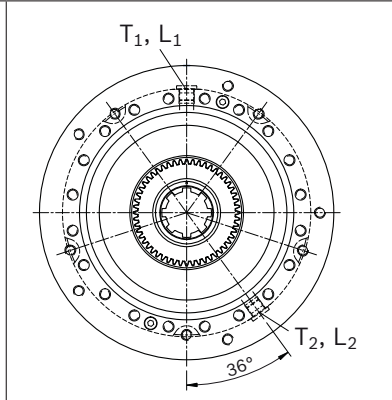

B700F

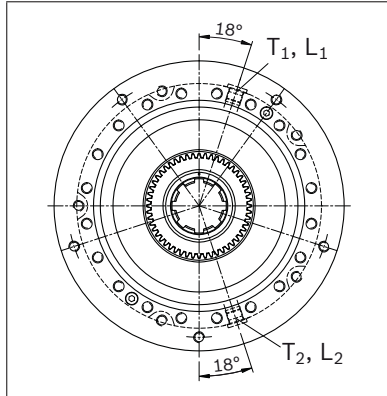

B1100G

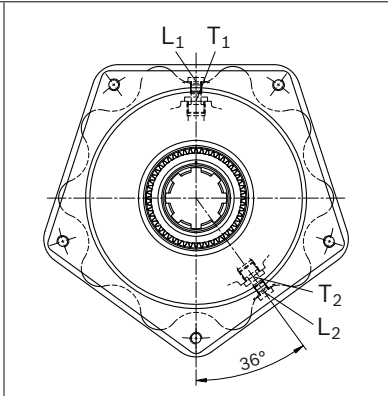

B1800H

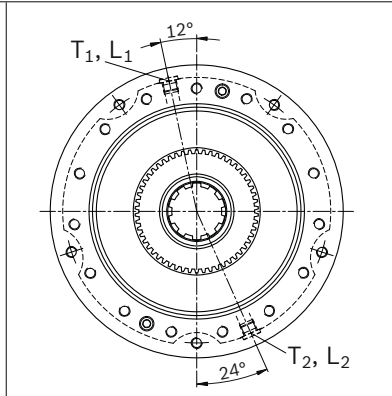

Key

L₁, L₂ Release pressure port

T₁, T₂ Case drain port

Installation dimensions in mm

RE 15228/08.2012, **Bosch Rexroth AG**

26 **MR, MRE** | Park brake

Measuring shaft

(2nd drive shaft end) for speed measuring - ports

Port Q1

Cylindrical shaft

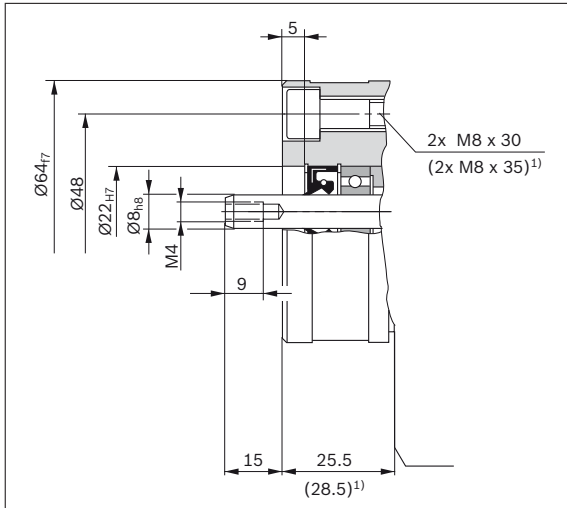

1) Motor MR125, 160, 190, 250, 300, MRE330

Incremental encoder

The hydraulic motors are equipped with an incremental encoder and are designed for all applications which require the precise measurement of the speed of the motor output shaft.

All Bosch Rexroth motors of the type MR are available with the incremental encoder. This solution is a package which includes the motor, the incremental encoder control unit, the incremental encoder and protection rating IP 67 (including connector socket).

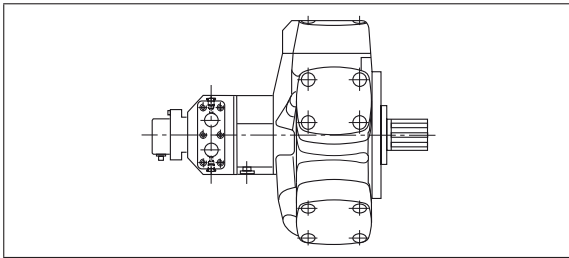

Dimensions

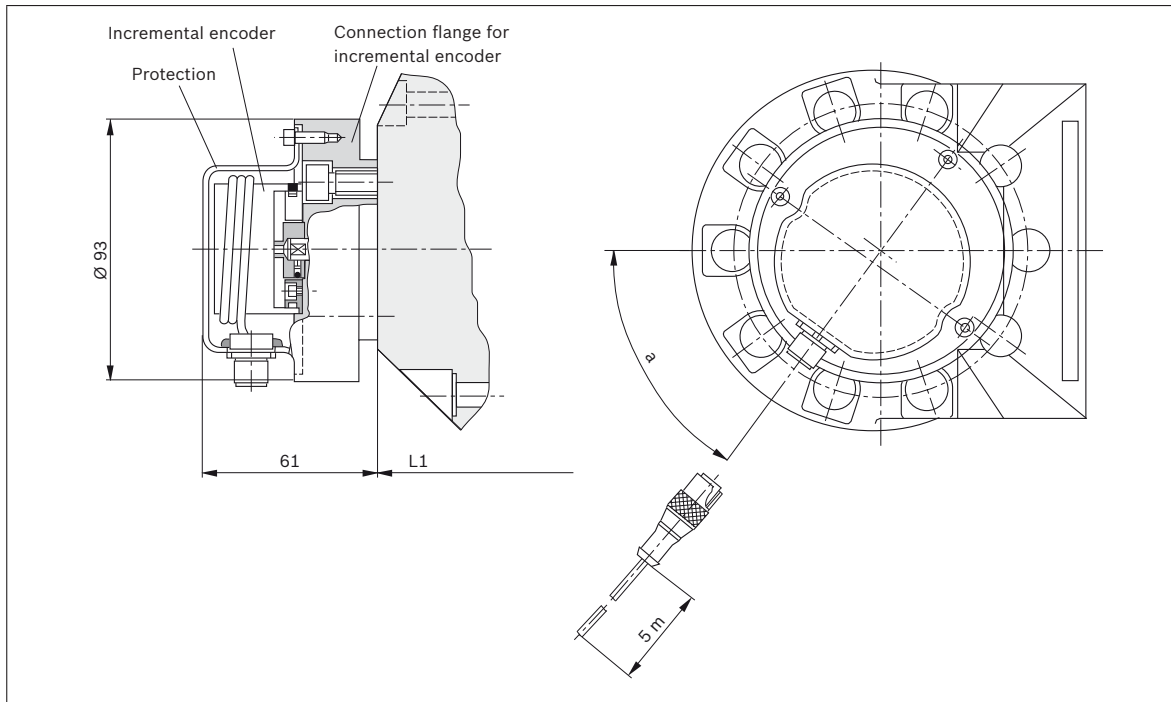

Sizes	α
MR125, 160, 190, 250, 300, MRE330	54°
For all other sizes	45°

Installation dimensions in mm

RE 15228/08.2012, **Bosch Rexroth AG**

28 MR, MRE | Incremental encoder

Connection diagram

▼ Version "M1"

Monodirectional

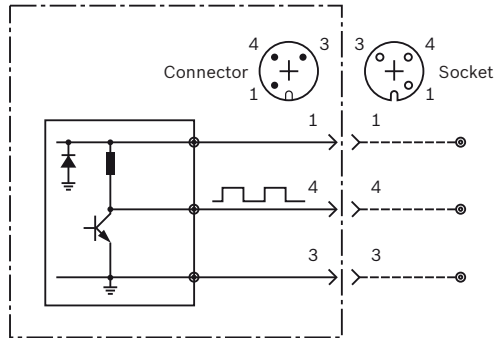

▼ Version "B1"

Bidirectional

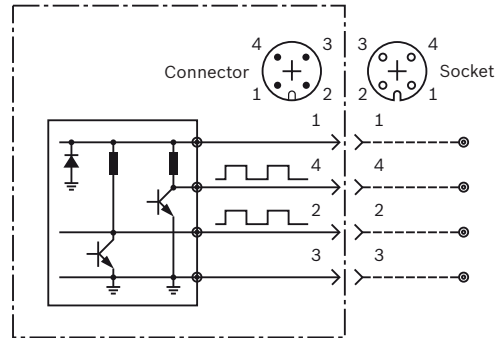

Wire color and function

Pin	Color	Function	Voltage/Current
1	Brown	Supply voltage	8 to 24 V DC
2	White	Signal output B	Maximum 10 mA and 24 Vcc
3	Blue	Supply voltage	0 V DC
4	Black	Signal output A	Maximum 10 mA and 24 Vcc

Technical data

Type	ELCIS mod. 478	
Supply voltage	Vcc	8 to 24
Current consumption	mA	maximum 120
Current output	mA	maximum 10
Signal output	Phase A monodirectional Phase A and B bidirectional	
Frequency range	kHz	maximum 100
Impulse count	500 (other values on request up to maximum 2540) / revolution	
Working temperature	°C	0 to 70
Storage temperature	°C	-30 to +85
Bearing service life	rpm	1.5 x 10 ⁹
Mass	gr	100
Type of protection	IP 67 (with installed protection and connector)	
Electric port	monodirectional	RSF 3/0.5 M (Lumberg) connector
		RKt 3-06/5 m (Lumberg) socket
	bidirectional	RSF 4/0.5 M (Lumberg) connector
		RKT 4-07/5 m (Lumberg) socket
connection cable	5 m long	

Bosch Rexroth AG, RE 15228/08.2012

Accessories

Coupling – splined shaft/hollow shaft

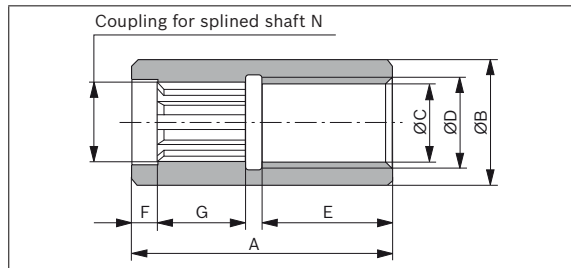

Motor type	MR125, 160, 190	MR250, 300 MRE330	MR350, 450 MRE500	MR600, 700 MRE800	MR1100 MRE1400	MR1600, 1800 MRE2100
Material number	R900024276	R900024277	R900024278	R900024279	R900024280	R900024281
A	114	135	155	171	186	224
ØB	56	71	80	90	106	118
ØC ^{H11}	39	49	55	61	73	83
ØD	47	60	68	75	88.5	98
E	54	64	68	80	85.5	107
F	15.5	15	18.5	19	20	22
G	34.5	45	55.5	59	65.5	78

Transition piece – splined shaft/shaft key

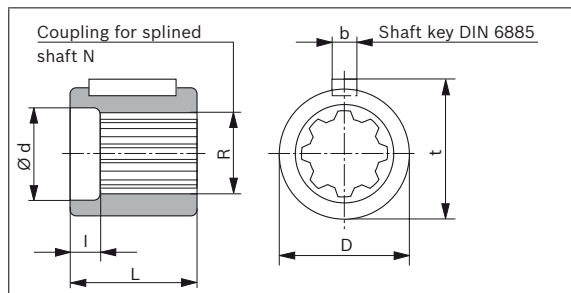

Motor type	MR125, 160,190	MR250, 300 MRE330	MR350, 450 MRE500	MR600, 700 MRE800	MR1100 MRE1400	MR1600, 1800 MRE2100
Material number	R900017858	R900017859	R900017860	R900017861	R900017862	R900017863
R	A8x32x38	A8x42x48	A8x46x54	A8x52x60	A8x62x72	A10x72x82
Ød	38.3	48.3	54.3	60.3	72.3	82.3
I	15.5	15	18.5	19	20	22
ØD _{k6}	58	70	80	90	105	118
L	50	60	75	80	98	118
b	10	14	16	18	20	22
t	61	73.5	84	94	109.5	123
Shaft key DIN 6885	10 x 8 x 4	14 x 9 x 56	16 x 10 x 70	18 x 11 x 70	20 x 12 x 90	22 x 14 x 110

Installation dimensions in mm

RE 15228/08.2012, **Bosch Rexroth AG**

30 **MR, MRE** | Accessories

Connection flange with pipe thread C1

Permissible up to 420 bar (6000 PSI)

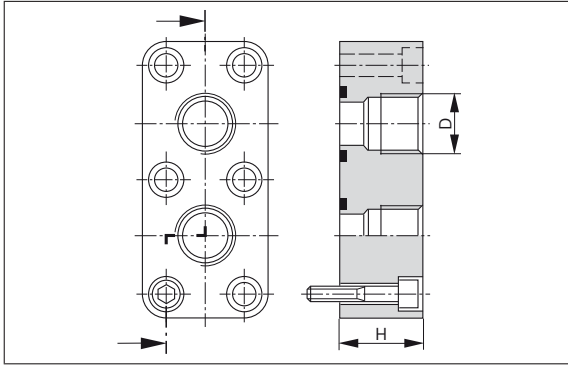

Motor type	MR125, 160, 190	MR250, 300 MRE330	MR350, 450 MRE500	MR600, 700 MRE800	MR1100 MRE1400	MR1600, 1800 MRE2100
D	G3/4	G3/4	G1 1/4	G1 1/4	G1 1/2	G1 1/2
H	36	36	40	40	45	45
Material number	R900017864	R900017864	R900017865	R900017865	R900017866	R900017866

SAE flange port

Options S1, T1, G1, L1

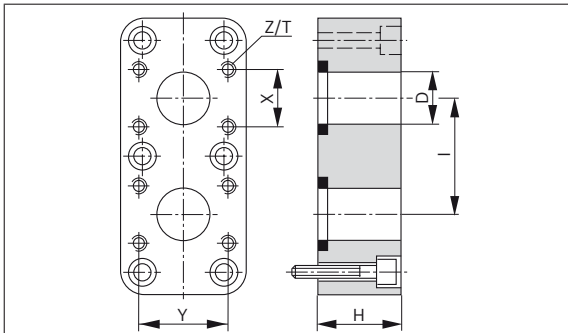

Motor type		MR125, 160, 190	MR250, 300 MRE330	MR350, 450 MRE500	MR600, 700 MRE800	MR1100 MRE1400	MR1600, 1800 MRE2100
SAE [PSI]		5000	5000	5000	5000	4000	4000
∅D	in	3/4	3/4	1	1	1 1/4	1 1/4
	[mm]	19	19	25	25	31	31
H		36	36	40	40	45	45
I		55	55	60	60	75	75
X		22.2	22.2	26.2	26.2	30.2	30.2
Y		47.6	47.6	52.4	52.4	58.7	58.7
Z/T	Metric	M10; 25 deep	M10; 25 deep	M10; 25 deep	M10; 25 deep	M10; 25 deep	M10; 25 deep
	Material number	R900024267	R900024267	R900024268	R900024268	R900024269	R900024269
Z/T	UNC	3/8 in; 16 deep	3/8 in; 16 deep	3/8 in; 16 deep	3/8 in; 16 deep	7/16 in; 14 deep	7/16 in; 14 deep
	Material number	On request	On request	R900244401	R900244401	R900244400	R900244400

Note

The flange is supplied complete with screws and seals.

Installation and commissioning notes

Leakage and flushing line – Routing examples

- ▶ Route the leakage line so that the motor cannot run at idle.
- ▶ Motors without shaft seal with mounted brake

Above-reservoir installation

Without brake

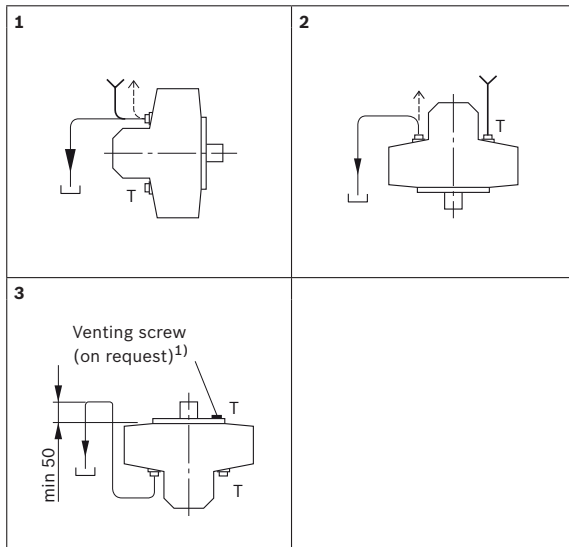

With brake²⁾

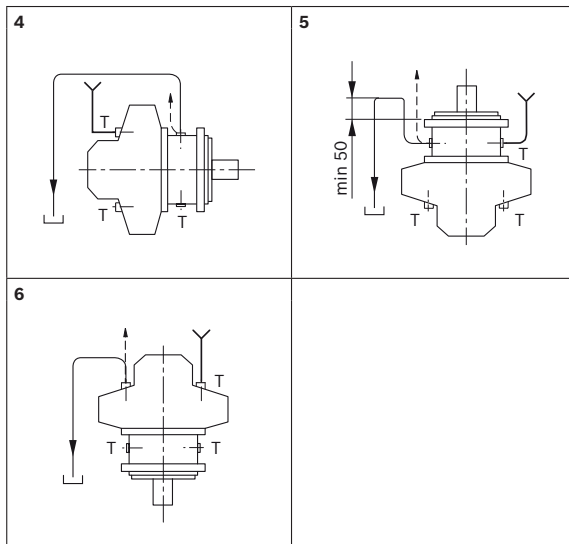

Below-reservoir installation

Without brake

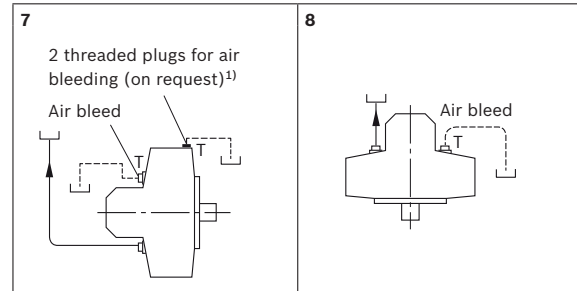

Radiator circuits for high-performance continuous operation

Flushing $p_{max} = 5$ bar

Without brake

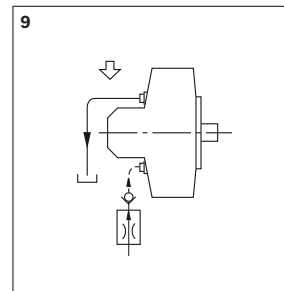

With brake²⁾

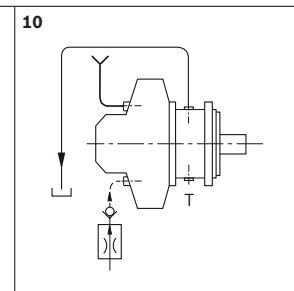

Key

T	Plug
Y	Motor housing filler neck
←--	Air bleed

1) Special versions for application in which a complete filling is required (e.g. in a saline atmosphere).

2) Case drain line: depressurized leakage return line to the reservoir

32 MR, MRE | Installation and commissioning notes

Mounting, securing

- ▶ Any installation position
Note leakage drain (see below)
- ▶ Align the motor well
Securing surface level, rigid
- ▶ Mounting bolts of at least strength class 10.9
Note specified tightening torque

Note

In frequent start/stop operations or at high reversing frequencies, use two mounting bolts as locating screws.

Coupling

Use the threaded bore in the output shaft for installation and removal

- ▶ Installation with screw
- ▶ Removal with pulling tool

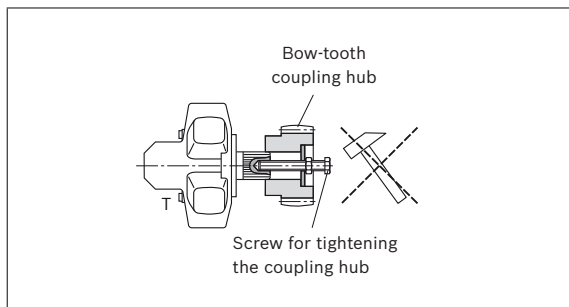

Pipelines, line ports

- ▶ Use suitable fittings.
Thread or flange ports, depending on the motor version
- ▶ Choose pipe and hose lines according to the application conditions. Note the manufacturer's instructions!
- ▶ Before commissioning, fill the motor and brake with hydraulic fluid. Use the specified filter!

© This document, as well as the data, specifications and other information set forth in it, are the exclusive property of Bosch Rexroth AG. It may not be reproduced or given to third parties without its consent. The data specified above only serve to describe the product. No statements concerning a certain condition or suitability for a certain application can be derived from our information. The information given does not release the user from the obligation of own judgment and verification. It must be remembered that our products are subject to a natural process of wear and aging.

Bosch Rexroth AG, RE 15228/08.2012