



## HC2D2 miniBOOSTER



**HC2D2 versions:** 8 different intensification factors

**P<sub>IN</sub>:** 20 – 207 bar (inlet pressure)

**P<sub>H</sub>:** 800 bar maximum (outlet pressure)

**P<sub>RETURN</sub>:** As low as possible (return pressure to tank)

**P<sub>OUTLET</sub>:**  $P_H = (P_{IN} - P_{RETURN}) \cdot i$  (intensification)

The intensification ratio is related to the inlet pressure at media 2, the values in the table are measured at 1 bar on media 2

**Drain connections:** Max. 5 bar

**Mounting:** Inline tube

**A model** = no dump valve

### Description

The HC2D2 is a dual media unit which is capable of delivering up to 3 l/ min flow on the high- pressure end. Like other miniBOOSTER models, the HC2D2 raises supplied pressure to a higher outlet pressure and automatically compensates for consumption of oil to maintain the high pressure.

Adjustment of the outlet pressure is carried out by varying the supplied pressure. Relative to its flow capability, the HC2D2 is a compact unit weighing 4.15 kg.

### Flow rates

Intensification factor i	Max. outlet flow l/ min	Max. inlet flow l/ min
1.2	4.2	6.0
1.6	3.2	6.0
2.2	2.7	7.0
3.0	2.1	7.0
4.0	1.6	7.0
5.6	1.3	8.0
8.0	1.0	8.0
12.0	0.6	8.0
10.1	–	15.0



## Dimensions

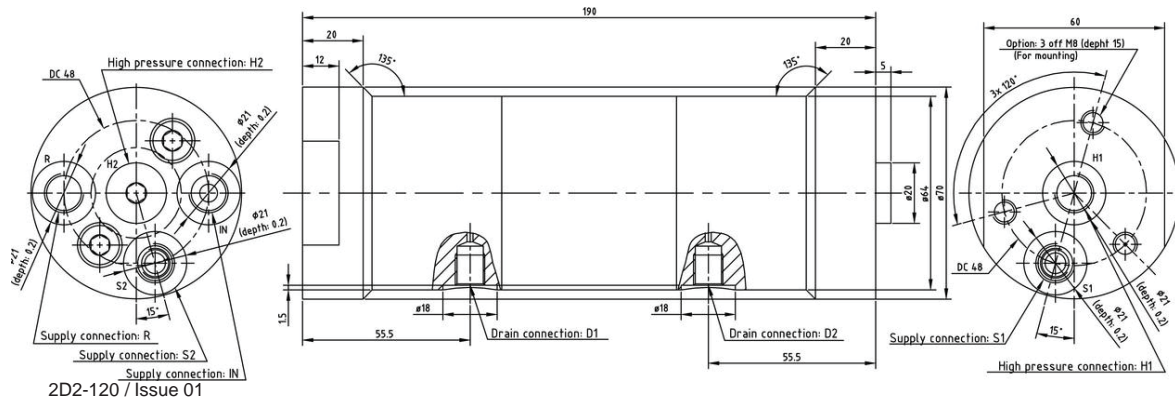

## Functions

The basic operation is illustrated in the function diagram. Media 1 is fed through the IN port flowing freely through the bistable valve BV1 driving the LP pistons. From the suction inlet IN Media 2 is drawn through the check valves 2 x KV1, and pumped through the 2 x KV2 to the high-pressure side H. In this condition, maximum flow through the booster is achieved giving a fast-forward function.

The unit will automatically stall when end pressure on the high-pressure side H is reached. If a pressure drop on the high-pressure side exists due to consumption or leakage, the HP1 and HP2 units will automatically operate to maintain the end pressure.

## Function Diagram

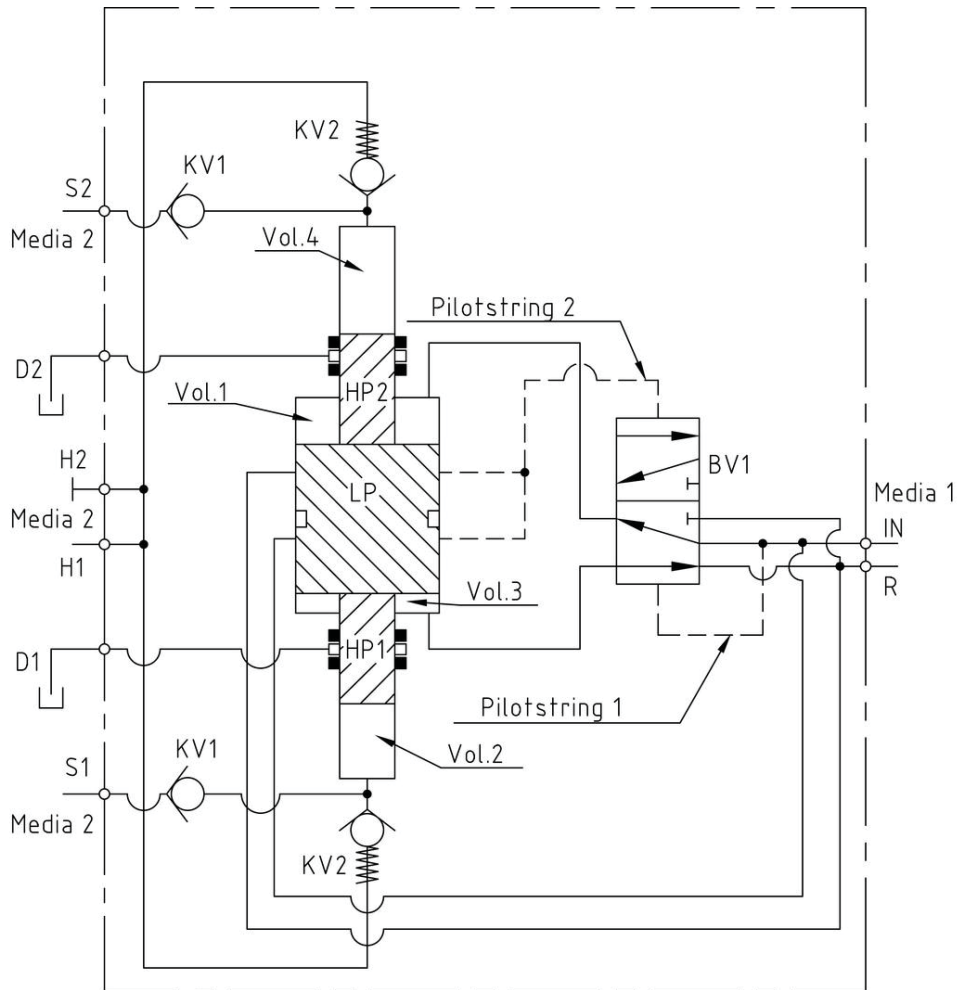

0-122 Model

## Connection types

Connection	IN / R	H1, S1, H2 & S2	D1 & D2
1	1/4" BSP	1/4" BSP	1/8" BSP

## Max. tightening torque BSP

	IN / R	H
	1/4" BSP	1/4" BSP
with steel washer	4.0 da/ Nm	4.0 da/ Nm
with aluminium washer	3.0 da/ Nm	-
with cutting edge	4.0 da/ Nm	4.0 da/ Nm

## Fluids

Media 1: Recognised hydraulic fluids, glycol solutions (Min > 5%)

Media 2: Hydraulic fluids, glycol

Please note! For other media, such as methanol, please contact miniBOOSTER

General specifications



## Materials

- Body, cast iron, internal components, steel: External surface, zinc chromate finish
- Dynamic seals, H- pur (other seal systems available)

General specifications

## Ordering an HC2D2

Ordering example of an HC2D2 with i = 3.9, with BSP connections: HC2D2 – 3.9 - A – 1HH

Model	Intensification, i	Dump valve	Connections
HC2D2	your selection...	your selection...	your selection...
	see flow rate table	A = (no) / A model	1

