

## 4/3-way servo solenoid directional control valves, pilot operated, with electrical position feedback (Lvdt DC/DC $\pm 10V$ )

**RE 29087/01.09**  
Replaces: 01.05

Type 4WRL 10...35, symbols E./W.

Sizes (NG) 10, 16, 25, 27, 35  
Unit series 3X  
Maximum working pressure P, A, B 350 bar (NG27: 280 bar)  
Nominal flow rate 80...1100 l/min ( $\Delta p = 10$  bar)

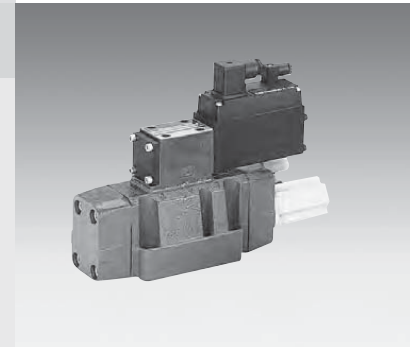

### List of contents



Contents	Page
Features	1
Ordering data	2
Accessories, function, sectional diagram	3
Control oil supply	4
Technical data	5 and 6
Valve with external trigger electronics	7 and 8
Characteristic curves	9 to 11
Unit dimensions	12 to 15

### Features

- Pilot operated 4/3-way servo solenoid directional control valves NG10 to NG35, with approx. 20% overlap
- Pilot valve NG6, with control piston and sleeve in servo quality, actuated on one side, 4/4 fail-safe position when switched off
- Control solenoid with electrical position feedback and electronics for position transducer (Lvdt DC/DC)
- Main stage with position feedback
- Spool with linear travel, with anti-rotation element
- Flow characteristic
  - S = Progressive
  - NG16, 25 and 27 with load tap C1/C2
- For subplate attachment, mounting hole configuration NG10 to ISO 4401-05-05-0-05, NG16 to ISO 4401-07-07-0-05, NG25/27 to ISO 4401-08-08-0-05 and NG35 to ISO 4401-10-09-0-05
- Subplates as per Technical Data Sheet, NG10 RE 45055, NG16 RE 45057, NG25/27 RE 45059 and NG35 RE 45060 (order separately)
- Plug-in connectors to DIN 43560-AM2  
Solenoid 2P+PE/M16 x 1.5, position transducer 4P/Pg7 included in delivery, see Technical Data Sheet RE 08008
- External trigger electronics (order separately)
  - Electric amplifier for standard curve without ramps
  - Electric amplifier with ramps and dead-band compensation



## Accessories, not included in delivery

	NG10	4 x ISO 4762-M6 x 40-10.9-N67F821 70	<b>2 910 151 209</b>
	NG16	2 x ISO 4762-M6 x 45-10.9-N67F821 70	<b>2 910 151 211</b>
		4 x ISO 4762-M10 x 50-10.9-N67F821 70	<b>2 910 151 301</b>
	NG25/27	6 x ISO 4762-M12 x 60-10.9-N67F821 70	<b>2 910 151 354</b>
	NG35	6 x ISO 4762-M20 x 90-10.9-N67F821 70	<b>2 910 151 532</b>
	VT-VRRA1-527-20/V0/2STV, see RE 30045		<b>0 811 405 063</b>
	VT-VRRA1-527-20/V0/RTS-2STV, see RE 30044		<b>0 811 405 073</b>
	2P+PE (M16 x 1.5) and 4P (Pg7) included in delivery, also see RE 08008		

## Testing and service equipment

– Test box type VT-PE-TB2, see RE 30064

– Test adapter type VT-PA-3, see RE 30070

## Function, sectional diagram

### Construction

The valve consists of two main assemblies:

- Pilot valve (1) with control spool and sleeve, return springs, control solenoid and inductive position transducer
- Main stage (2) with centering springs and position feedback

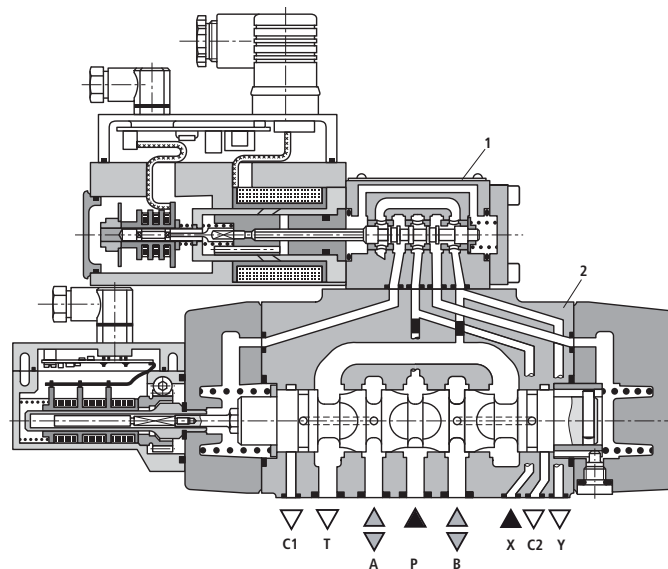

### Functional description

When the control solenoid is not actuated, the control spool is held by springs in the fail-safe position, and the main stage spool remains in spring-centered mid position.

In the on-board electronics, the pre-defined setpoint is compared with the actual value for the position of the main stage control spool. In the event of an error signal, the control solenoid is actuated, and the pilot spool is moved as the magnetic force changes. The flow released through the control cross-sections causes the main control spool to move. If the input setpoint is 0 V, the main stage control spool is spring-centered in overlapped mid position. The control oil is conveyed to the pilot valve either internally via port P or externally via port X. The oil returns to the tank internally via port T or externally via port Y.

### Power failure

In the event of a power failure or an open circuit, the on-board electronics cut off the electricity to the control solenoid and the pilot spool moves to the fail-safe position, relieving the control oil chambers of the main stage. The main stage control spool is spring-centered in mid position.

## Control oil supply

The pilot valve can be supplied both via ports X and Y (externally) and via the main flow channels P and T.

NG10, 25, 27, 35

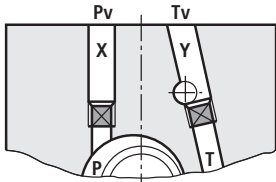

NG16

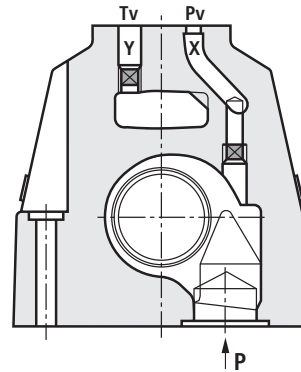

Type...-3X...

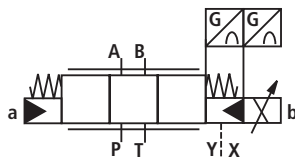

Type...-3X...E...

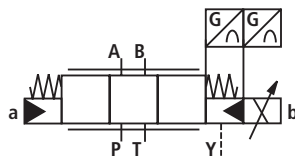

Type...-3X...ET...

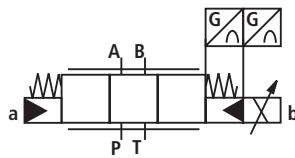

Type...-3X...T...

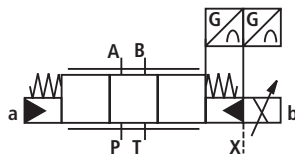

Symbol in detail  
(external control oil inlet and outlet)

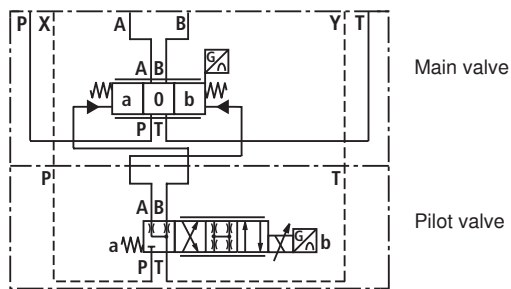

<b>No designation =</b>	"x" = external	"y" = external
<b>E =</b>	"x" = internal	"y" = external
<b>ET =</b>	"x" = internal	"y" = internal
<b>T =</b>	"x" = external	"y" = internal

## Technical data

### General

Construction	Spool type valve, pilot operated					
Actuation	Servo solenoid directional control valve NG6, with position controller for pilot valve and main stage, external electric amplifier					
Type of mounting	Subplate, mounting hole configuration NG10...35 to ISO 4401-...					
Installation position	Optional					
Ambient temperature range	°C	-20...+50				
Weight	kg	NG10 8.35	NG16 10	NG25 18	NG27 18	NG35 80
Vibration resistance, test condition	Max. 25 g, shaken in 3 dimensions (24 h)					

### Hydraulic (measured with HLP 46, $\vartheta_{oil} = 40\text{ °C} \pm 5\text{ °C}$ )

Pressure fluid	Hydraulic oil to DIN 51524...535, other fluids after prior consultation					
Viscosity range	recommended	mm <sup>2</sup> /s 20...100				
	max. permitted	mm <sup>2</sup> /s 10...800				
Pressure fluid temperature range	°C	-20...+80				
Maximum permissible degree of contamination of pressure fluid	Purity class to ISO 4406 (c) Class 18/16/13 <sup>1)</sup>					
Flow direction	See symbol					
Nominal flow at $\Delta p = 5\text{ bar per notch}^2)$	l/min	NG10 80	NG16 180	NG25 350	NG27 430	NG35 1100
Max. working pressure	Ports P, A, B (external control oil inlet)	bar 350	bar 350	bar 350	bar 280	bar 350
	Ports P, A, B, X	bar 280				
	Ports T, Y	bar 250				
Min. control oil pressure in "pilot stage"	bar	8				
$Q_{max}$	l/min	170	450	900	1000	3000
$Q_N$ pilot valve (inlet)	l/min	2	4	12	12	40
$\Delta p = 35\text{ bar}$	l/min	2	4	12	12	40
Leakage of pilot valve at X = 100 bar	cm <sup>3</sup> /min	<150	<180	<350	<500	<1100
Leakage of main stage control spool symbols "E" at P = 100 bar	l/min	<0.25	<0.4	<0.6	<0.6	<1.1

### Static/Dynamic

Overlap in mid position	≈ 18...22% of spool stroke, electrically adjustable for $U_{D-E} \pm 0.5\text{ V}$ with 0 811 404 073					
Spool stroke, main stage	± mm	4	7	10	10	12.5
Control oil volume of main stage 100%	cm <sup>3</sup>	1.1	4.3	11.3	11.3	41.5
Control oil requirement 0...100%, (at X = 100 bar)	l/min	2.2	4.7	11.7	11.7	15.6
Hysteresis	%	<0.1 scarcely measurable				
Manufacturing tolerance	See flow curves, adjustable with 0 811 404 073					
Response time for 0...100%, (at X = 100 bar)	ms	<40	<80	<80	<80	<130
Response time for 0...100%, (at X = 10 bar)	ms	<150	<250	<250	<250	<500
Switch-off behavior	After electrical switch-off (pilot valve in fail-safe) Main stage moves to spring-centered overlapped mid position					
Thermal drift	<1% at $\Delta T = 40\text{ °C}$					

<sup>1)</sup> The purity classes stated for the components must be complied with in hydraulic systems. Effective filtration prevents problems and also extends the service life of components. For a selection of filters, see Technical Data Sheets RE 50070, RE 50076 and RE 50081.

<sup>2)</sup> Flow rate at a different  $\Delta p$   $Q_x = Q_{nom} \cdot \sqrt{\frac{\Delta p_x}{5}}$

## Technical data

### Electrical

Cyclic duration factor	%	100 ED
Power supply		24 V DC <sub>nom</sub> (external electric amplifier)
Degree of protection		IP 65 to DIN 40050
Solenoid connector		Connector DIN 43560/ISO 4400 M16 x 1.5 (2P+PE)
Position transducer connector		Connector Pg7 (4P)
Max. solenoid current	A	2.7
Coil resistance $R_{20}$	$\Omega$	2.5
Max. power consumption at 100% load and operating temperature	VA	40
Position transducer DC/DC technology		Supply: +15 V/35 mA -15 V/25 mA Signal: 0...±10 V ( $R_L \geq 10 \text{ k}\Omega$ )

All characteristics only in connection with valve amplifier 0 811 405 063

### Important

Pilot operated 4/3-way servo solenoid directional control valves with positive overlap function in open or closed-loop-controlled axes and have approx. 20% overlap when switched off. This condition does not constitute an active fail-safe position. For this reason, many applications require the use of "external check valves", which must be taken into account during the On/Off switching sequence.

## Valve with external trigger electronics (standard: without ramps, overlap compensation)

### Block diagram/pin assignment

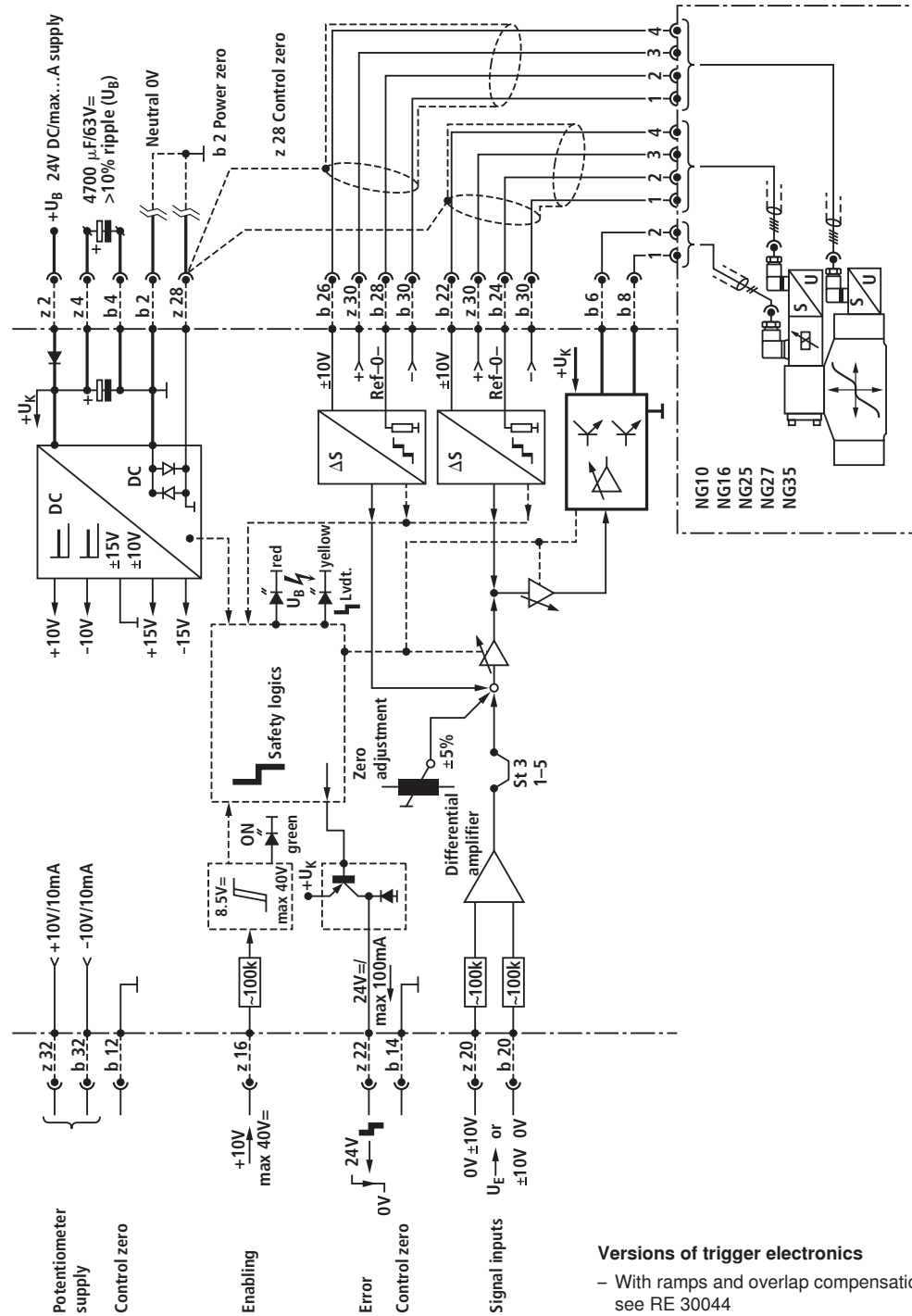

## Valve with external trigger electronics (standard: with ramps, overlap compensation)

### Block diagram/pin assignment

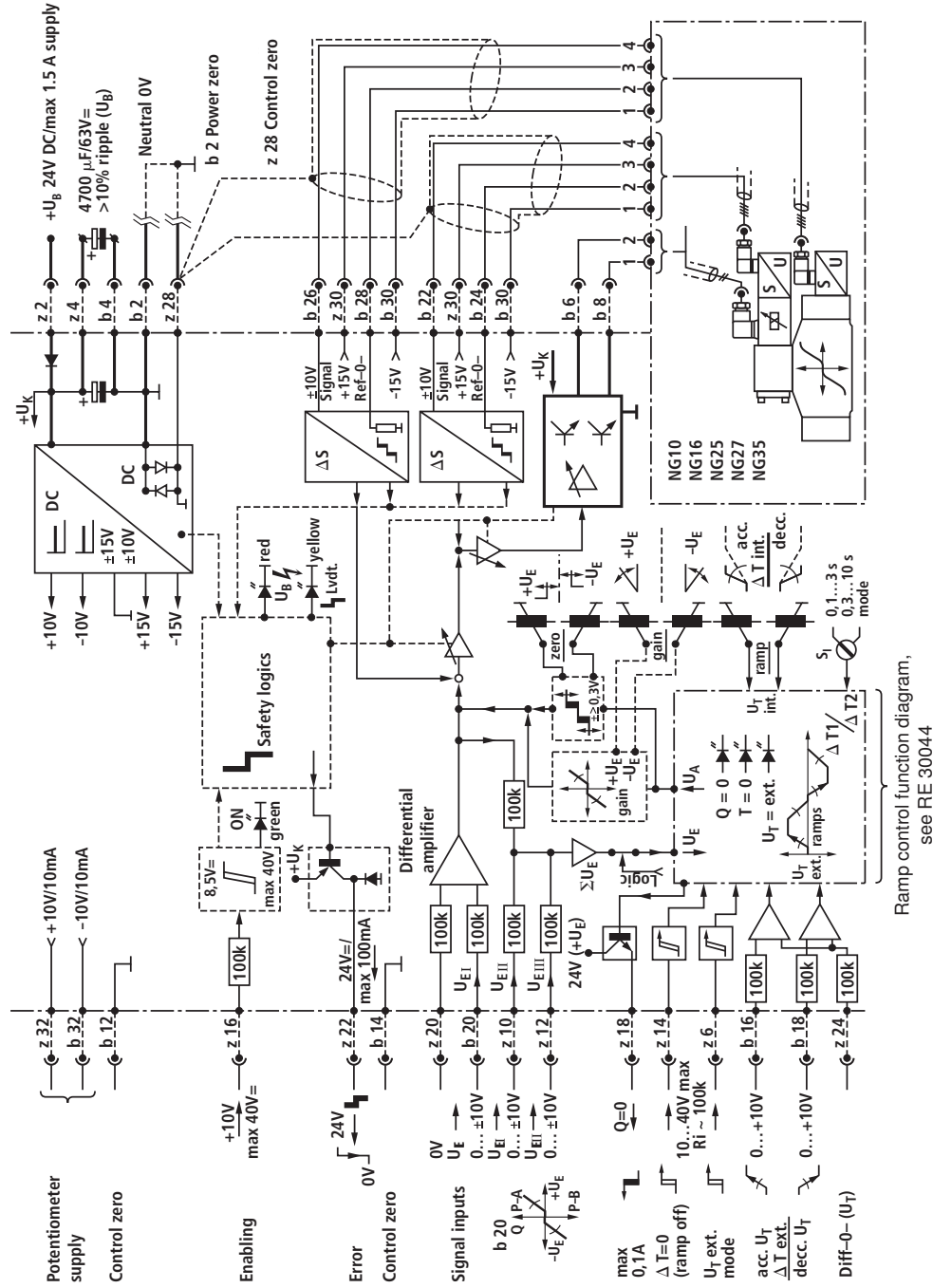

### Versions of trigger electronics

- With standard linear curve, see RE 30045



## Characteristic curves (measured with HLP 46, $\vartheta_{oil} = 40 \text{ }^\circ\text{C} \pm 5 \text{ }^\circ\text{C}$ )

### Flow rate – signal function

$$Q = f(U_E)$$

Symbol E(Z), W(Z) ( $Q_A:Q_B = 1:1$ )

E1(Z), W1(Z) ( $Q_A:Q_B = 2:1$ )

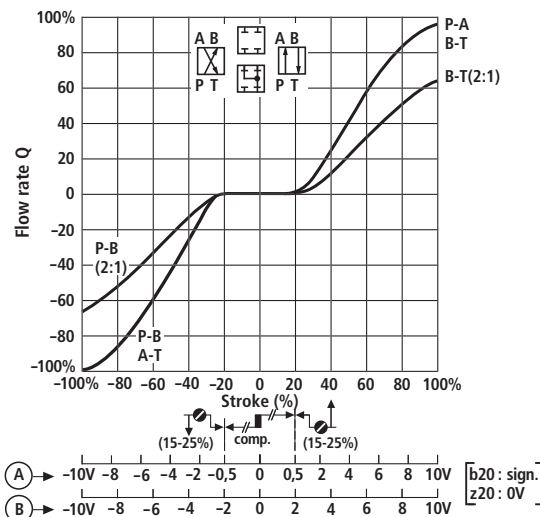

### Control spool with asymmetric metering notches

Control spools with asymmetric metering notches are available in a ratio of 2:1 for the purpose of adaptation to differential cylinders.

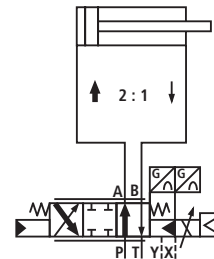

### Flow in mid position, “leakage oil pressure relief”

With symbol “E”, leakage oil in the two work chambers A and B of the control piston gives rise to a build-up of pressure in A or B, which then causes a connecting cylinder to drift out of position.

In many cases, the “W” symbol is a better solution. With a setpoint of “0”, the control piston moves into the overlapped mid position. In this mid position, pressure is then relieved from ports A and B with  $1\% + 0.5\% Q_N$  to T. This also supports the function of external check valves.

Symbol E4, W4 ( $Q_A:Q_B = 2:1$ )

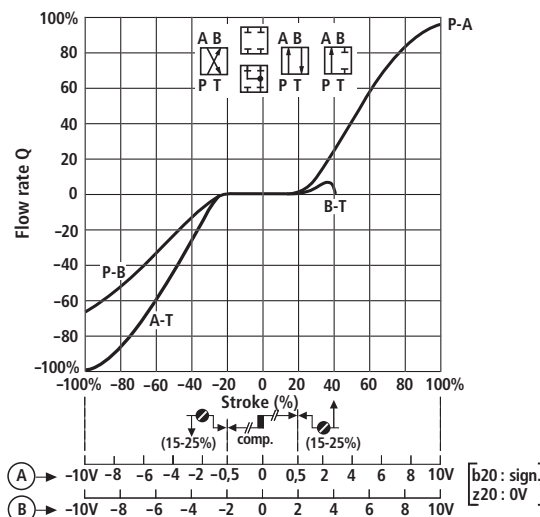

Amplifier (A) with ramp 0 811 405 073 – RE 30044  
(B) without ramp 0 811 405 063 – RE 30045

### Control spools in a differential circuit

In order to produce differential circuits, valve spools with a 4th position are available. It is sufficient to install a non-return valve in the consumer lines.

In addition, a control spool (symbol) with internal B-P connection is employed for certain branch-oriented solutions. However, we recommend that you consult the BRH Application Center with regard to these special symbols, as a simulation or knowledge of this type of system is usually required.

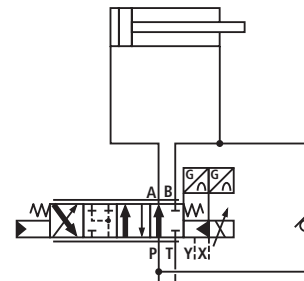

## Characteristic curves (measured with HLP 46, $\vartheta_{oil} = 40\text{ }^{\circ}\text{C} \pm 5\text{ }^{\circ}\text{C}$ )

### Load tap C1/C2

To compensate for fluctuations in the load or supply pressure, 4/3-way servo solenoid directional control valves are combined with pressure compensators. The load is tapped via a shuttle valve for the NG10 and 35, and via two additional ports C1 and C2 for the NG16, 25 and 27 ("4WRL" and "4WRLE" only).

The pressure compensator therefore always receives the correct pressure signal even in the event of negative load. When using pressure compensators, an external control oil supply should always be selected.

### NG10, 35

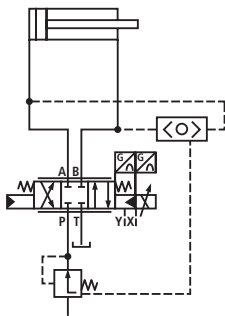

### NG16, 25, 27

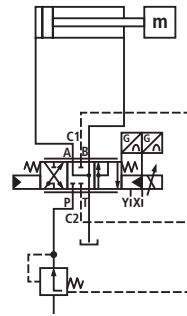

## Characteristic curves (measured with HLP 46, $\vartheta_{oil} = 40 \text{ }^\circ\text{C} \pm 5 \text{ }^\circ\text{C}$ )

Response time (at X = 100 bar)

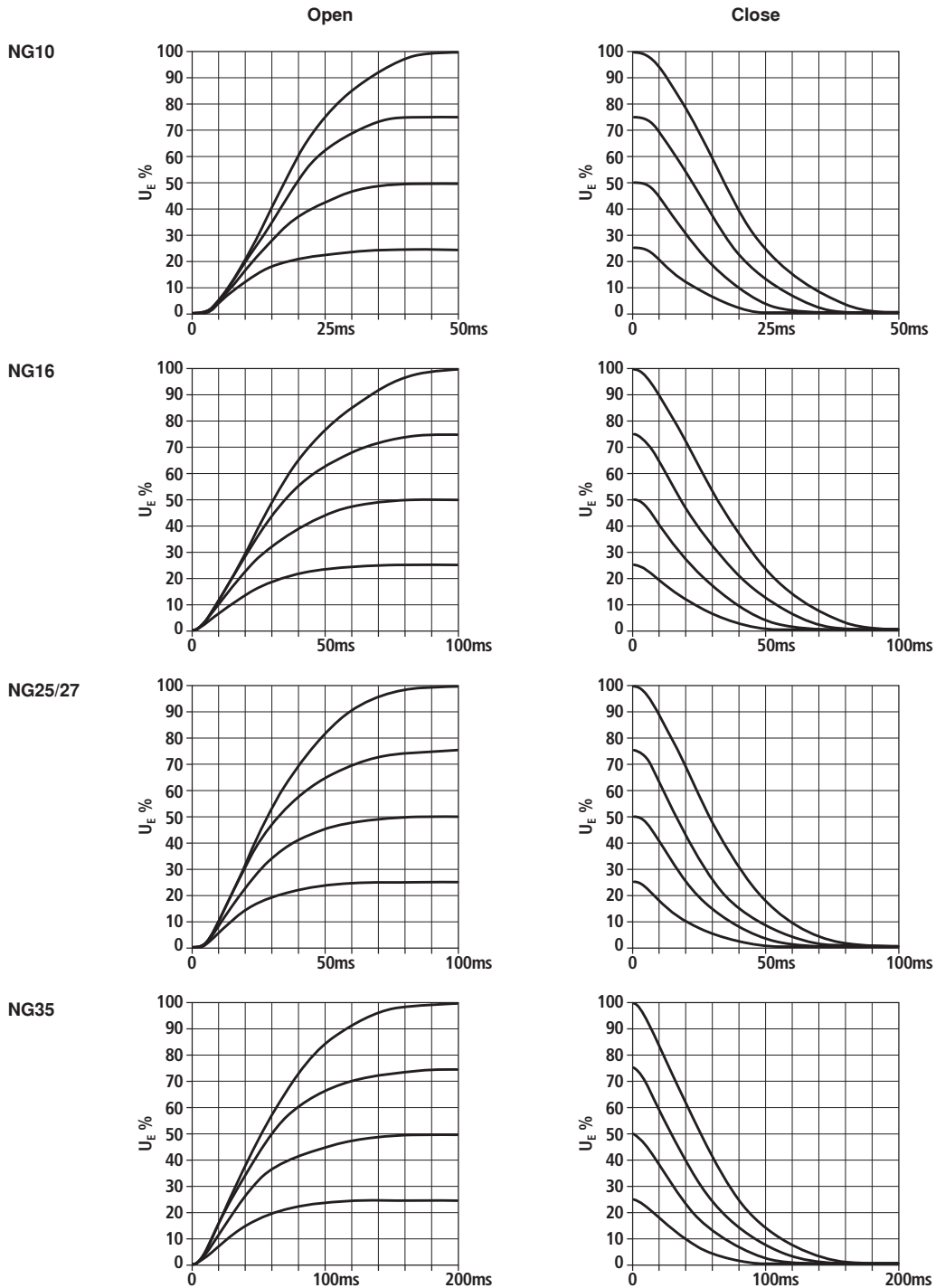

## Unit dimensions NG10 (nominal dimensions in mm)

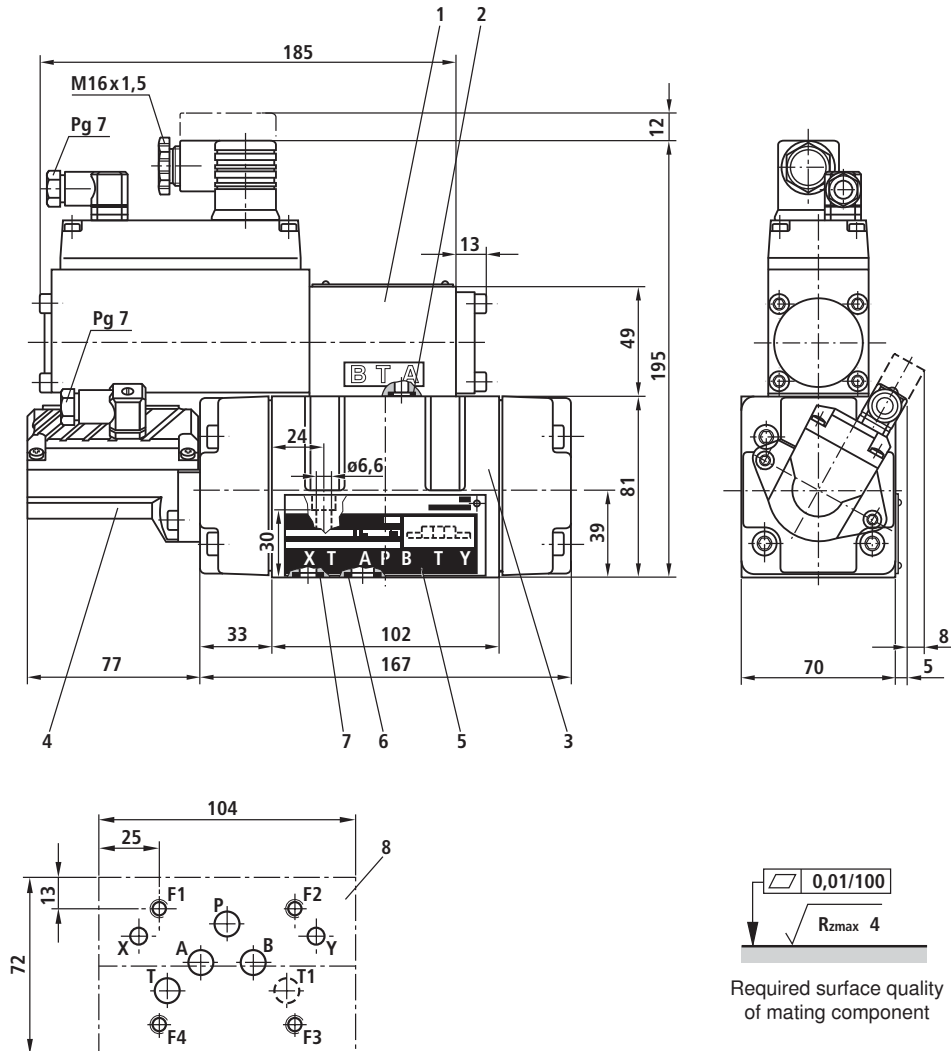

- 1 Pilot valve
- 2 O-ring 9.25 x 1.78 (ports P, A, B, T)
- 3 Main valve
- 4 Inductive position transducer (main valve)
- 5 Nameplate
- 6 O-ring 12 x 2 (ports P, A, B, T, T1)
- 7 O-ring 10 x 2 (ports X, Y)

- 8 Machined valve contact surface, mounting hole configuration according to ISO 4401-05-05-0-05  
Deviates from standard:  
Ports P, A, B, T, T1  $\varnothing 10.5$  mm  
Minimum thread depth: Ferrous metal  $1.5 \times \varnothing$   
Non-ferrous  $2 \times \varnothing$

**Subplates**, see Technical Data Sheet RE 45055

**Valve fastening bolts** (order separately)

The following valve fastening bolts are recommended:

**4 cheese-head bolts ISO 4762-M6x40-10.9-N67F821 70**  
(galvanized in accordance with Bosch standard N67F821 70)  
Tightening torque  $M_A = 11 \pm 3$  Nm

Material no. **2910151209**

# HYQUIP

## Unit dimensions NG25/27 (nominal dimensions in mm)

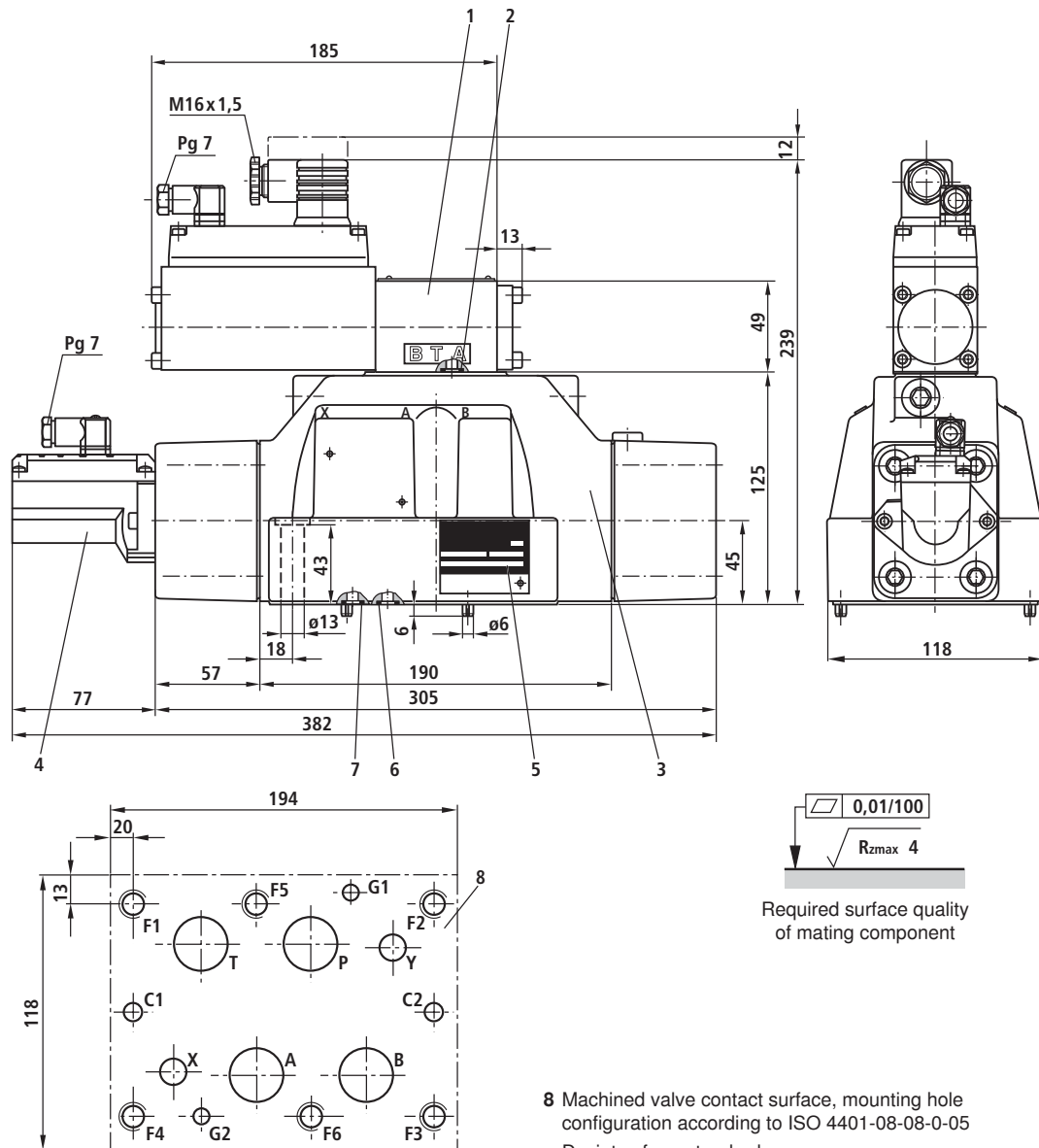

- 1 Pilot valve
- 2 O-ring 9.25 x 1.78 (ports P, A, B, T)
- 3 Main valve
- 4 Inductive position transducer (main valve)
- 5 Nameplate
- 6 O-ring (ports P, A, B, T)  
NG25: 28 x 3  
NG27: 34.6 x 2.62
- 7 O-ring 15 x 2.5 (ports X, Y, C1, C2)

8 Machined valve contact surface, mounting hole configuration according to ISO 4401-08-08-0-05

Deviates from standard:

NG25: Ports P, A, B, T  $\varnothing$  25 mm

NG27: Ports P, A, B, T  $\varnothing$  32 mm

Minimum thread depth: Ferrous metal 1.5 x  $\varnothing$

Non-ferrous 2 x  $\varnothing$

**Subplates**, see Technical Data Sheet RE 45059

**Valve fastening bolts** (order separately)

The following valve fastening bolts are recommended:

**6 cheese-head bolts ISO 4762-M12x60-10.9-N67F821 70**

(galvanized in accordance with Bosch standard N67F821 70)

Tightening torque NG25  $M_A = 90+30$  Nm,

NG27  $M_A = 90\pm 15$  Nm

Material no. **2910151354**

## Unit dimensions NG35 (nominal dimensions in mm)

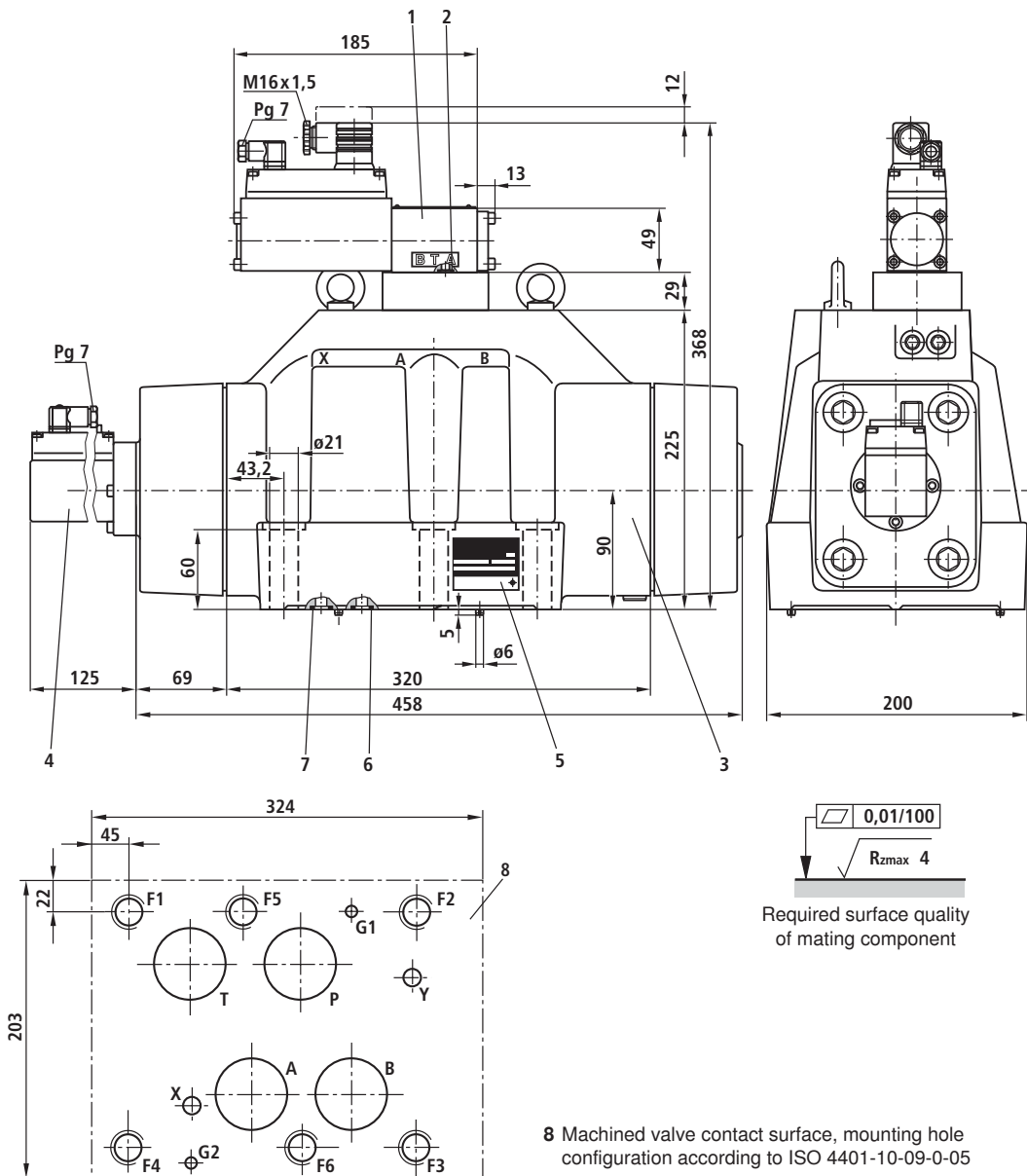

- 1 Pilot valve
- 2 O-ring 9.25 x 1.78 (ports P, A, B, T)
- 3 Main valve
- 4 Inductive position transducer (main valve)
- 5 Nameplate
- 6 O-ring 53.57 x 3.53 (ports P, A, B, T)
- 7 O-ring 15 x 2.5 (ports X, Y)

8 Machined valve contact surface, mounting hole configuration according to ISO 4401-10-09-0-05

Deviates from standard:

Ports P, A, B, T  $\phi$  48 mm

Minimum thread depth: Ferrous metal 1.5 x  $\phi$

Non-ferrous 2 x  $\phi$

**Subplates**, see Technical Data Sheet RE 45060

**Valve fastening bolts** (order separately)

The following valve fastening bolts are recommended:

**6 cheese-head bolts ISO 4762-M20x90-10.9-N67F821 70**

(galvanized in accordance with Bosch standard N67F821 70)

Tightening torque  $M_A = 450+110$  Nm

Material no. **2910151532**

## Notes

---

© This document, as well as the data, specifications and other information set forth in it, are the exclusive property of Bosch Rexroth AG. It may not be reproduced or given to third parties without its consent.  
The data specified above only serve to describe the product. No statements concerning a certain condition or suitability for a certain application can be derived from our information. The information given does not release the user from the obligation of own judgment and verification. It must be remembered that our products are subject to a natural process of wear and aging.